



Operation **Manual**

Goodrive270 Series **VFD for Fan and Pump**



SHENZHEN INVT ELECTRIC CO., LTD.

No.	Change description	Version	Changed on
1	First release.	V1.0	May 2021
2	<ul style="list-style-type: none"> ● Added product data about the 1.5–22kW VFD models. ● Added the description of the expansion card EC-IO-503-00 in appendix A.4. ● Added appendix D.8 List of other optional accessories. ● Corrected minor errors. 	V1.1	April 2022
3	<ul style="list-style-type: none"> ● Modified figures: Position of U-type short connector in section 4.4.2 and External keypad interface in section 4.5. ● Modified the function descriptions and figure in section 5.5.12 Digital output. ● Modified some function codes in chapter 6. ● Updated communication card models to be EC-TX503D, EC-TX505C and EC-TX509C respectively in section A.5. ● Modified data of Table C-1–C-7 and updated 220–500kW dimension drawings in section C.4. ● Deleted contents of IP20 protection upgrade assembly in section D.8. 	V1.2	December 2022
4	<ul style="list-style-type: none"> ● Modified model code and description in section 3.5. ● Modified 1.5kW–132kW VFD models and notes in section 3.6, and updated VFD models in other sections. ● Modified Figure 4-19 and Figure 4-41. ● Modified notes of sections 4.2.3 and 4.3.2. ● Modified the keypad description in sections 5.2 and 5.3, and added the LCD keypad display and operation in section 5.4. ● Modified Figure 5-29, and added Figure 5-30 and Figure 5-31 in section 5.5.16. ● Modified the function parameter list in section 6.2, and updated other function parameters in other sections. ● Deleted the command code 08H from section 9.4. ● Deleted the indicator definition contents from Appendix A. ● Modified the EMC content in section B.4.1. 	V1.3	August 2023

No.	Change description	Version	Changed on
	<ul style="list-style-type: none"> ● Modified the keypad structure diagram and keypad mounting bracket description in section C.2. ● Modified the product dimensions and diagrams in section C.4. ● Modified reactor model selection table in section D.6. ● Modified filter contents in section D.7 and added section D.7.1.1 SCHAFFNER input filters. ● Deleted the description of altitude exceeding 3000m. 		
5	<ul style="list-style-type: none"> ● Updated product models and added models with built-in filters. ● Added PTC temperature detection function*. ● Added fan control noise reduction function*. ● Added the function to select grid frequencies (50/60Hz) and voltage levels (within 380–480V range). ● Added new communication expansion card information for software adaptation: EtherNet IP*, BACnet MS/TP*, Modbus TCP communication card*, 24V power supply expansion card*. <p>Note: Updates with "*" require support from software versions V1.06 and later. Please refer to P07.13 for version information.</p> <ul style="list-style-type: none"> ● Updated the selection of harmonic filters. ● Added installation of 1.5–7.5kW output magnetic ring to meet C2 level requirements. ● Added sections 3.7 Product heat dissipation, 4.2.3 Cabinet design, 4.2.4 Installation instructions for reverse connection of input aluminum bars, 4.2.5 Top cardboard removal instructions. ● Added recommended cable size, brand, and models in section 4.3.1.1 Length requirements of motor cables. ● Added output filter selection for motor cable lengths. ● Updated section B.4.1 EMC compatibility and motor cable length. ● Updated section 6.2 Function parameter list. ● Updated section 5.5 Basic operation description. 	V1.4	July 2025

No.	Change description	Version	Changed on
	<ul style="list-style-type: none">● Added sections 4.2.6 and 5.5.35.● Updated section 5.5.16.1.● Added screw location diagrams in section 7.7.4.● Added product information of 560–800kW VFD models.		

Preface

Thank you for choosing Goodrive270 series variable-frequency drive (VFD).

If not otherwise specified, the VFD in the manual always indicates Goodrive270 series VFD, which is an optimized VFD special for fan and pump. Simple and easy to use, the VFD can drive the fans and pumps in wastewater treatment, HVAC, chemical, metallurgical, electric power and other industries.

Using advanced vector control technologies, the VFD can drive both synchronous motors (SMs) and asynchronous motors (AMs) in various complex work conditions. In addition, the VFD has been embedded with various fan and pump application macros, such as PID, multi-pump control, constant pressure water supply, effectively relieving engineers from the difficulty in debugging. The VFD uses an independent air duct design and thickened circuit board coating, helping to adapt to hostile environments, ensuring long and reliable run, and reducing maintenance cost. The VFD also supports communication bus add-on, such as CAN bus and PROFINET bus, providing better industrial control system compatibility. The VFD power density is improved, facilitating the in-cabinet design and reducing customer system costs. The VFD circuit optimization design has excellent electromagnetic compatibility characteristics to ensure stable run in complex electromagnetic environments.

This manual instructs you how to install, wire, set parameters for, diagnose and remove faults for, and maintain the VFD, and also lists related precautions. Before installing the VFD, read through this manual carefully to ensure the proper installation and running with the excellent performance and powerful functions into full play.

The manual is subject to change without prior notice.

Contents

- 1 Safety precautions 1**
 - 1.1 What this chapter contains 1
 - 1.2 Safety definition 1
 - 1.3 Warning symbols 1
 - 1.4 Safety guidelines..... 2
 - 1.4.1 Delivery and installation..... 2
 - 1.4.2 Commissioning and running 3
 - 1.4.3 Maintenance and component replacement 4
 - 1.4.4 Disposal 4
- 2 Quick startup..... 5**
 - 2.1 What this chapter contains 5
 - 2.2 Unpacking inspection 5
 - 2.3 Checking before use 5
 - 2.4 Environment checking 5
 - 2.5 Checking after installation 6
 - 2.6 Basic commissioning..... 7
- 3 Product overview 8**
 - 3.1 What this chapter contains 8
 - 3.2 Basic principles 8
 - 3.3 Product specifications 9
 - 3.4 Product nameplate 11
 - 3.5 Model designation code 11
 - 3.6 Product ratings..... 12
 - 3.7 Product heat dissipation 13
 - 3.8 Structure 15
- 4 Installation guidelines 18**
 - 4.1 What this chapter contains 18
 - 4.2 Mechanical installation 18
 - 4.2.1 Installation environment..... 18
 - 4.2.2 Mounting method 19
 - 4.2.3 Cabinet design 20
 - 4.2.4 Installation instructions for reverse connection of input aluminum bars..... 32
 - 4.2.5 Top cardboard removal instructions 33
 - 4.2.6 VFD cabinet installation..... 33
 - 4.3 Electrical installation..... 40
 - 4.3.1 Main circuit wiring..... 40
 - 4.3.2 Main circuit terminals..... 41
 - 4.3.3 Wiring procedure for main circuit terminals 52

4.3.4 Wiring of basic control circuit	52
4.3.5 Input/output signal connection	54
4.3.6 External optional keypad wiring	55
4.3.7 Wiring protection	56
5 Basic operation guidelines.....	58
5.1 What this chapter contains	58
5.2 Operation procedure	58
5.3 LED keypad (BOP-270) display and operation.....	58
5.3.1 Displaying stopped-state parameters.....	60
5.3.2 Displaying running-state parameters	60
5.3.3 Displaying fault alarms	61
5.3.4 Editing function codes	61
5.3.5 Modifying function codes	61
5.3.6 Setting a password for the VFD	62
5.3.7 Viewing VFD status	63
5.4 LCD keypad (SOP-270) display and operation	63
5.4.1 Displaying stopped-state parameters.....	66
5.4.2 Displaying running-state parameters	67
5.4.3 Displaying fault alarms	67
5.4.4 Enter/exit menu	68
5.4.5 Editing list	72
5.4.6 Adding parameters to the parameter list displayed in stopped/running state.....	73
5.4.7 Add parameter to common parameter setup list.....	74
5.4.8 Parameter selection edit interface.....	74
5.4.9 Parameter setup edit interface.....	75
5.4.10 State monitoring interface.....	75
5.4.11 Motor parameter autotuning	76
5.4.12 Parameter backup	76
5.4.13 System setting.....	77
5.4.14 Power-on guiding settings	77
5.5 Basic operation description	79
5.5.1 What this section describes	79
5.5.2 Common commissioning procedure.....	80
5.5.3 Vector control.....	84
5.5.4 Space voltage vector control mode.....	89
5.5.5 Torque control	97
5.5.6 Motor parameters	102
5.5.7 Start/stop control	107
5.5.8 Frequency setting.....	111
5.5.9 Analog input	116

5.5.10 Analog output.....	118
5.5.11 Digital input.....	122
5.5.12 Digital output.....	129
5.5.13 Simple PLC.....	134
5.5.14 Multi-step speed running.....	136
5.5.15 PID control.....	138
5.5.16 Water pump control.....	143
5.5.17 PID function only for water supply.....	155
5.5.18 Segmented wind and water pressure function (used with LCD keypad).....	155
5.5.19 Automatic sleep.....	156
5.5.20 Water level control.....	158
5.5.21 Pump cleaning.....	159
5.5.22 Water pipe break detection control.....	160
5.5.23 Water pipe soft padding.....	161
5.5.24 Freezing protection.....	162
5.5.25 Condensation protection.....	163
5.5.26 Anti-stalling and dry pumping function.....	164
5.5.27 Speed tracking function.....	165
5.5.28 Motor thermal protection function.....	166
5.5.29 Real-time clock function (Keypad with button battery).....	168
5.5.30 Fire ride-through control.....	169
5.5.31 Fault classification.....	170
5.5.32 Input phase loss detection.....	172
5.5.33 Carrier frequency reduction with temperature.....	172
5.5.34 Cooling fan noise control.....	173
5.5.35 Grid frequency and voltage selection.....	174
6 Function parameter list.....	176
6.1 What this chapter contains.....	176
6.2 Function parameter list.....	176
Group P00—Basic functions.....	177
Group P01—Start and stop control.....	182
Group P02—Parameters of motor 1.....	189
Group P03—Vector control of motor 1.....	192
Group P04—V/F control.....	200
Group P05—Input terminals.....	208
Group P06—Output terminals.....	217
Group P07—Human-machine interface.....	222
Group P08—Enhanced functions.....	229
Group P09—PID control.....	239
Group P10—Simple PLC and multi-step speed control.....	245

Group P11—Protection parameters	248
Group P12—Parameters of motor 2.....	263
Group P13—SM control.....	266
Group P14—Serial communication	267
Group P15—Communication expansion card 1 functions.....	272
Group P16—Functions of communication expansion card 2.....	278
Group P17—Status viewing.....	283
Group P19—Expansion card status viewing.....	288
Group P23—Vector control of motor 2	289
Group P25—I/O card input functions.....	291
Group P26—I/O card output functions	294
Group P28—Master/slave control	297
Group P89—HVAC status viewing.....	298
Group P90—PID1 control	300
Group P91—PID2 control	304
Group P92—Real-time clock and timer (available at use of LCD keypad).....	308
Group P93—Fire control.....	308
Group P94—Multi-pump and fan control functions.....	309
Group P95—Multi-section water pressure function (LCD keypad required).....	314
Group P96—Multi-pump and fan protection function.....	315
7 Troubleshooting.....	320
7.1 What this chapter contains	320
7.2 Indications of alarms and faults	320
7.3 Fault reset.....	320
7.4 Fault history	320
7.5 Faults and solutions	320
7.5.1 Faults and solutions	320
7.5.2 Other status	327
7.6 Analysis on common faults.....	328
7.6.1 Motor fails to work	328
7.6.2 Motor vibrates	329
7.6.3 Overvoltage.....	329
7.6.4 Undervoltage.....	330
7.6.5 Motor overheating	331
7.6.6 VFD overheating	332
7.6.7 Motor stalls during ACC.....	333
7.6.8 Overcurrent.....	334
7.7 Countermeasures on common interference	334
7.7.1 Interference on meter switches and sensors.....	334
7.7.2 Interference on RS485 communication.....	336

7.7.3 Failure to stop and indicator shimmering due to motor cable coupling.....	337
7.7.4 Leakage current and interference on RCD.....	337
7.7.5 Live device chassis	342
8 Maintenance.....	343
8.1 What this chapter contains	343
8.2 Periodical maintenance	343
8.3 Cooling fan.....	346
8.4 Capacitor	349
8.4.1 Capacitor reforming.....	349
8.4.2 Electrolytic capacitor replacement	350
8.5 Power cable.....	350
9 Communication protocol.....	351
9.1 What this chapter contains	351
9.2 Modbus protocol introduction	351
9.3 Application of Modbus	351
9.3.1 RS485.....	351
9.3.2 RTU mode	354
9.4 RTU command codes and communication data.....	357
9.4.1 Command code 03H, reading N words (continuously up to 16 words).....	357
9.4.2 Command code 06H, writing a word	359
9.4.3 Command code 10H, continuous writing.....	360
9.4.4 Data address definition.....	360
9.4.5 Fieldbus scale	365
9.4.6 Error message response	366
9.4.7 Reading and writing examples.....	367
9.5 Common communication faults	372
Appendix A Expansion card.....	373
A.1 Model definition	373
A.2 Dimensions and installation	375
A.3 Wiring.....	377
A.4 I/O expansion cards.....	378
A.4.1 EC-IO501-00	378
A.4.2 EC-IO503-00	380
A.5 Communication cards.....	382
A.5.1 PROFIBUS-DP communication card (EC-TX503D)	382
A.5.2 CAN multi-protocol communication card (EC-TX505D).....	383
A.5.3 PROFINET communication card (EC-TX509C)	385
A.5.4 EtherNet IP and Modbus TCP protocol communication card (EC-TX510B).....	387
A.5.5 BACnet MSTP communication card (EC-TX507B)	389
A.5.6 24V power supply expansion card (EC-PS501-24).....	391

Appendix B Technical data	392
B.1 What this chapter contains.....	392
B.2 Derated application.....	392
B.2.1 Capacity	392
B.2.2 Derating.....	392
B.3 Grid specifications	393
B.4 Motor connection data	393
B.4.1 EMC compatibility and motor cable length.....	393
B.5 Application standards	394
B.5.1 CE marking.....	394
B.5.2 EMC compliance declaration.....	394
B.6 EMC regulations	394
Appendix C Dimension drawings.....	396
C.1 What this chapter contains.....	396
C.2 Keypad structure	396
C.2.1 Structure diagram	396
C.2.2 External installation of keypad.....	396
C.3 VFD structure	398
C.4 Product dimensions	399
C.4.1 Wall-mounting dimensions	399
C.4.2 Flange installation dimensions	402
C.4.3 Floor installation dimensions	404
Appendix D Optional peripheral accessories.....	408
D.1 Wiring of peripheral accessories	408
D.2 Power supply.....	409
D.3 Cable	409
D.3.1 Power cable.....	409
D.3.2 Control cable	410
D.3.3 Recommended cable size.....	411
D.3.4 Cable arrangement	414
D.3.5 Insulation inspection	415
D.4 Breaker and electromagnetic contactor	415
D.5 Harmonic filters	416
D.6 EMC filter	419
D.7 List of other optional accessories	420
Appendix E STO function (for -EU models only).....	421
E.1 Safety standards.....	421
E.2 Safety function description	422
E.3 Risk assessment	423
E.4 STO wiring.....	423

E.5 STO function terminal description	425
E.6 STO function logic table.....	425
E.7 STO channel delay description	425
E.8 Acceptance test	426
Appendix F Effecieny.....	428
Appendix G Further information	430
G.1 Product and service queries	430
G.2 Feedback on INVT VFD manuals	430
G.3 Documents on the Internet	430

1 Safety precautions

1.1 What this chapter contains

Read this manual carefully and follow all safety precautions before moving, installing, operating and servicing the product. Otherwise, equipment damage or physical injury or death may be caused.

We shall not be liable or responsible for any equipment damage or physical injury or death caused due to your or your customers' failure to follow the safety precautions.

1.2 Safety definition

Danger: Severe personal injury or even death can result if related requirements are not followed.













Warning: Personal injury or equipment damage can result if related requirements are not followed.

Note: Actions taken to ensure proper running.





Trained and qualified professionals: People operating the equipment must have received professional electrical and safety training and obtained the certificates, and must be familiar with all steps and requirements of equipment installing, commissioning, running and maintaining and capable to prevent any emergencies.

1.3 Warning symbols

Warnings caution you about conditions that can result in severe injury or death and/or equipment damage and advice on how to prevent dangers. The following table lists the warning symbols in this manual.

Symbol	Name	Description	Abbreviation
 Danger	Danger	Severe personal injury or even death can result if related requirements are not followed.	
 Warning	Warning	Personal injury or equipment damage can result if related requirements are not followed.	
 Forbid	Electrostatic sensitive	The PCBA may be damaged if related requirements are not followed.	
 Hot	Hot sides	Do not touch. The VFD base may become hot.	
 5 min	Electric shock	As high voltage still presents in the bus capacitor after power off, wait for at least five minutes (or 15 min / 25 min, depending on the warning symbols on the machine) after power off to prevent electric shock.	 5 min
	Read manual	Read the operation manual before operating the equipment.	
Note	Note	Actions taken to ensure proper running.	Note

1.4 Safety guidelines

	<ul style="list-style-type: none"> ◇ Only trained and qualified professionals are allowed to carry out related operations. ◇ Do not perform wiring, inspection or component replacement when power supply is applied. Ensure all the input power supplies have been disconnected before wiring or inspection, and wait for at least the time designated on the VFD or until the DC bus voltage is less than 36V. The minimum waiting time is listed in the following. <table border="1" data-bbox="297 429 930 563" style="margin-left: auto; margin-right: auto;"> <thead> <tr> <th style="width: 15%;"></th> <th style="width: 40%;">VFD model</th> <th style="width: 45%;">Minimum waiting time</th> </tr> </thead> <tbody> <tr> <td rowspan="3" style="text-align: center; vertical-align: middle;">380V</td> <td style="text-align: center;">1.5kW–110kW</td> <td style="text-align: center;">5 minutes</td> </tr> <tr> <td style="text-align: center;">132kW–315kW</td> <td style="text-align: center;">15 minutes</td> </tr> <tr> <td style="text-align: center;">355kW and higher</td> <td style="text-align: center;">25 minutes</td> </tr> </tbody> </table>		VFD model	Minimum waiting time	380V	1.5kW–110kW	5 minutes	132kW–315kW	15 minutes	355kW and higher	25 minutes
	VFD model	Minimum waiting time									
380V	1.5kW–110kW	5 minutes									
	132kW–315kW	15 minutes									
	355kW and higher	25 minutes									
	<ul style="list-style-type: none"> ◇ Do not refit the VFD unless authorized; otherwise fire, electric shock or other injury may result. 										
	<ul style="list-style-type: none"> ◇ The base may become hot when the machine is running. Do not touch. Otherwise, you may get burnt. 										
	<ul style="list-style-type: none"> ◇ The electrical parts and components inside the VFD are electrostatic sensitive. Take measurements to prevent electrostatic discharge when performing related operations. 										

1.4.1 Delivery and installation

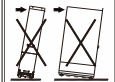
	<ul style="list-style-type: none"> ◇ Do not install the inverter on inflammables. In addition, prevent the inverter from contacting or adhering to inflammables. ◇ Do not run the VFD if it is damaged or incomplete. ◇ Do not contact the VFD with damp objects or body parts. Otherwise, electric shock may result.
	<ul style="list-style-type: none"> ◇ Do not push the VFD sideward during moving. ◇ Prevent the VFD from tipping sideward.

Note:

- ◇ Select appropriate tools for VFD delivery and installation to ensure the safe and proper running and avoid physical injury or death. To ensure personal safety, take mechanical protective measures like wearing safety shoes and working uniforms.
- ◇ Protect the VFD against physical shock or vibration during the delivery and installation.
- ◇ Do not carry the product only by its front cover as the cover may fall off.
- ◇ The installation site must be away from children and other public places.
- ◇ When the altitude exceeds 1000m, derate by 1% for every increase of 100m.

- ✧ Use the VFD in proper environments. (For details, see section 4.2.1 Installation environment.)
- ✧ Prevent the screws, cables and other conductive parts from falling into the VFD.
- ✧ As leakage current of the VFD during running may exceed 3.5mA, ground properly and ensure the grounding resistance is less than 10Ω. The conductivity of PE grounding conductor is the same as that of the phase conductor (with the same cross sectional area).
- ✧ R, S and T are the power input terminals, and U, V and W are the output motor terminals. Connect the input power cables and motor cables properly; otherwise, damage to the VFD may occur.

1.4.2 Commissioning and running

	<ul style="list-style-type: none"> ✧ Cut off all power supplies connected to the VFD before terminal wiring, and wait for at least the time designated on the VFD after disconnecting the power supplies. ✧ High voltage presents inside the VFD during running. Do not carry out any operation on the VFD during running except for keypad setup. The VFD control terminals form extra-low voltage (ELV) circuits. Therefore, you need to prevent the control terminals from connecting to accessible terminals of other devices when there is no isolation protection mechanism configured. ✧ The VFD may start up by itself when P01.21 is set to 1 (restart after power off). Do not get close to the VFD and motor. ✧ The VFD cannot be used as an "Emergency-stop device". ✧ The VFD cannot act as an emergency brake for the motor; it is a must to install a mechanical braking device. ✧ During driving a permanent magnet SM, besides above-mentioned items, the following work must be done before installation and maintenance: <ul style="list-style-type: none"> ✓All input power supplies have been disconnected, including the main power and control power. ✓The permanent-magnet SM has been stopped, and the voltage on output end of the VFD is lower than 36V. ✓After the permanent-magnet SM has stopped, wait for at least the time designated on the VFD, and ensure the voltage between + and - is lower than 36V. ✓During operation, it is a must to ensure the permanent-magnet SM cannot run again by the action of external load; it is recommended to install an effective external braking device or cut off the direct electrical connection between the permanent-magnet SM and the VFD.
---	--

Note:

- ✧ Do not switch on or switch off the input power supplies of the VFD frequently.
- ✧ If the VFD has been stored without use for a long time, perform capacitor reforming (described in

chapter 8 Maintenance), inspection and pilot run for the VFD before the reuse.

- ✧ Close the VFD front cover before running; otherwise, electric shock may occur.



1.4.3 Maintenance and component replacement

	<ul style="list-style-type: none"> ✧ Only trained and qualified professionals are allowed to perform maintenance, inspection, and component replacement for the VFD. ✧ Cut off all power supplies connected to the VFD before terminal wiring, and wait for at least the time designated on the VFD after disconnecting the power supplies. ✧ During maintenance and component replacement, take measures to prevent screws, cables and other conductive matters from falling into the internal of the VFD.
---	--

Note:

- ✧ Use proper torque to tighten screws.
- ✧ During maintenance and component replacement, keep the VFD and its parts and components away from combustible materials and ensure they have no combustible materials adhered.
- ✧ Do not carry out insulation voltage-endurance test on the VFD, or measure the control circuits of the VFD with a megohmmeter.
- ✧ During maintenance and component replacement, take proper anti-static measures on the VFD and its internal parts.

1.4.4 Disposal

	<ul style="list-style-type: none"> ✧ The VFD contains heavy metals. Dispose of a scrap VFD as industrial waste.
	<ul style="list-style-type: none"> ✧ Dispose of a scrap product separately at an appropriate collection point but not place it in the normal waste stream.

2 Quick startup

2.1 What this chapter contains

This chapter introduces the basic installation and commissioning rules that you need to follow to realize quick installation and commissioning.

2.2 Unpacking inspection

Check the following after receiving the product.

1. Whether the packing box is damaged or dampened. If any problems are found, contact the local INVT dealer or office.
2. Whether the model identifier on the exterior surface of the packing box is consistent with the purchased model. If any problems are found, contact the local INVT dealer or office.
3. Whether the interior surface of the packing box is abnormal, for example, in wet condition, or whether the enclosure of the VFD is damaged or cracked. If any problems are found, contact the local INVT dealer or office.
4. Whether the VFD nameplate is consistent with the model identifier on the exterior surface of the packing box. If any problems are found, contact the local INVT dealer or office.
5. Whether the accessories (including the manual, keypad, and expansion card) inside the packing box are complete. If any problems are found, contact the local INVT dealer or office.

2.3 Checking before use

Check the following before using the VFD.

1. Mechanical type of the load to be driven by the VFD to verify whether the VFD will be overloaded during work. Whether the power class of the VFD needs to be increased.
2. Whether the actual running current of the motor is less than the rated current of the product.
3. Whether the control accuracy required by the load is the same as that is provided by the VFD.
4. Whether the grid voltage is consistent with the rated voltage of the VFD.
5. Check whether expansion cards are needed for selected functions.

2.4 Environment checking

Check the following before installing the VFD:

1. Whether the actual ambient temperature exceeds 40°C. When the temperature exceeds 40°C, derate 1% for every increase of 1°C. Do not use the VFD when the ambient temperature exceeds 50°C. Note: When the VFD is built in a cabinet, the ambient temperature is the temperature of air in the cabinet.

2. Whether the actual ambient temperature is lower -10°C . If the temperature is lower than -10°C , use heating devices. Note: When the VFD is built in a cabinet, the ambient temperature is the temperature of air in the cabinet.
3. Whether the altitude of the application site exceeds 1000m. When the installation site altitude exceeds 1000 m, derate 1% for every increase of 100m.
4. Whether the actual environment humidity exceeds 90% or condensation occurs. If yes, take additional protective measures.
5. Whether there is direct sunlight or biological invasion in the environment where the VFD is to be used. If yes, take additional protective measures.
6. Whether there is dust or inflammable and explosive gas in the environment where the VFD is to be used. If yes, take additional protective measures.

2.5 Checking after installation

Check the following after the VFD installation is complete.

1. Whether the input power cables and motor cables meet the current-carrying capacity requirements of the actual load.
2. Whether correct accessories are selected for the VFD, the accessories are correctly and properly installed, and the installation cables meet the capacity carrying requirements of all components (including the input reactor, input filter, output reactor, output filter, and DC reactor).
3. Whether the product is installed on non-flammable materials and the heat-radiating accessories (such as reactors) are away from flammable materials.
4. Whether all the control cables and power cables are separately routed and whether EMC specification requirements are taken into full account during the routing.
5. Whether all grounding systems are properly grounded according to the requirements of the VFD.
6. Whether all the installation clearances of the VFD meet the requirements in the manual.
7. Whether the installation mode conforms to the instructions in the operation manual. Vertical installation is recommended whenever possible.
8. Whether the external connection terminals of the product are tightly fastened and the torque is appropriate.
9. Whether there are screws, cables, or other conductive items left in the VFD. If yes, get them out.

2.6 Basic commissioning

Complete the basic commissioning as follows before the actual use of the VFD:

- | |
|--|
| 1. According to the actual motor parameters, select the motor type, set motor parameters, and select the VFD control mode. |
| 2. Check whether autotuning is required. If possible, de-couple the VFD from the motor load to start dynamic parameter autotuning. If the VFD cannot be de-coupled from the load, perform static autotuning. |
| 3. Adjust the ACC/DEC time according to the actual work condition of the load. |
| 4. Perform device commissioning by means of jogging and check whether the motor rotational direction is correct. If not, change the rotation direction by swapping any two phase wires of the motor. |
| 5. Set all control parameters and then perform actual run. |

3 Product overview

3.1 What this chapter contains

This chapter mainly introduces the working principles, product features, layouts, nameplates and model designation rules.

3.2 Basic principles

The VFD is used to control asynchronous AC induction motors and permanent magnetic synchronous motors. The following figure shows the main circuit diagram of the VFD. The rectifier converts 3PH AC voltage into DC voltage, the capacitor bank of intermediate circuit stabilizes the DC voltage, and then the inverter converts DC voltage into AC voltage that can be used by an AC motor.

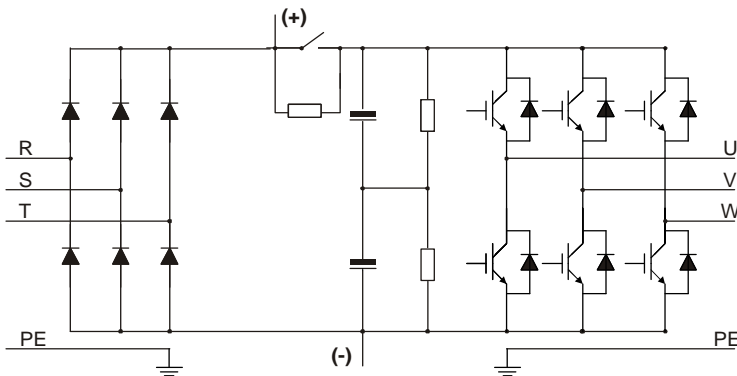

Figure 3-1 1.5–355kW main circuit of VFD models (optional DC reactors for 1.5–355kW models)

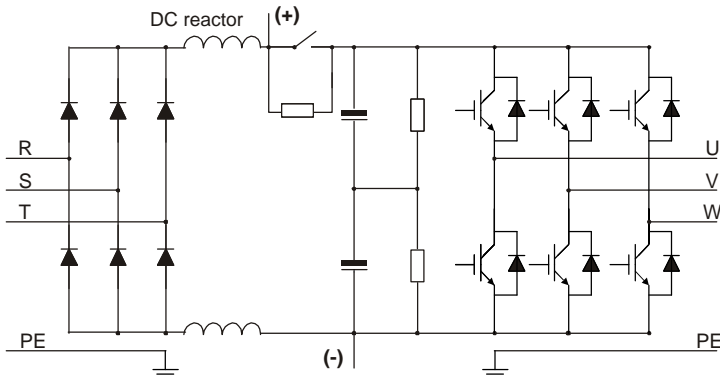

Figure 3-2 400–630kW main circuit (built-in DC reactors)

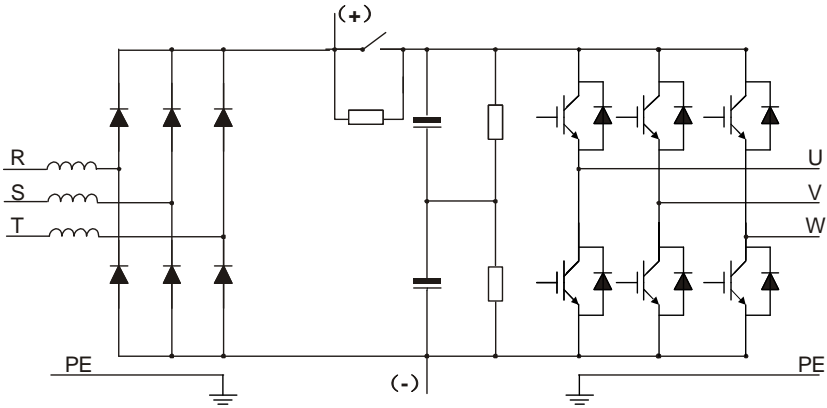

Figure 3-3 710–800kW main circuit (built-in DC reactors)

Note: Built-in DC reactors are standard parts only for 400–630kW models.

3.3 Product specifications

Function description		Specifications
Power input	Input voltage (V)	AC 3PH 380–480V, rated voltage: 380V
	Allowed voltage transient fluctuation	-15%–+10%
	Input current (A)	For details, see section 3.6 "Product ratings".
	Input frequency (Hz)	50Hz or 60Hz; Allowed range: 47–63Hz
Power output	Output voltage (V)	0–Input voltage
	Output current (A)	For details, see section 3.6 "Product ratings".
	Output power (kW)	For details, see section 3.6 "Product ratings".
	Output frequency (Hz)	0–400Hz
Technical control performance	Control mode	Space voltage vector control, and sensorless vector control (SVC)
	Motor type	Asynchronous motor (AM) and permanent magnetic synchronous motor (SM)
	Speed ratio	For asynchronous motors (AMs): 1:200 (SVC); for synchronous motors (SMs): 1:20 (SVC)
	Speed control accuracy	± 0.2% (SVC)
	Speed fluctuation	± 0.3% (SVC)
	Torque response	< 20ms (SVC)
	Torque control accuracy	± 10% (SVC)
Overload capacity	Able to run at 110% of rated current for 1min, and an overload allowed for every 5min.	

Function description		Specifications
Running control performance	Frequency setting method	Settings can be implemented through digital, analog, pulse frequency, multi-step speed run, simple PLC, PID, and communication. Settings can be combined and the setting channels can be switched.
	Automatic voltage regulation	The output voltage can be kept constant although the grid voltage changes.
	Fault protection	Many protection functions available, such as protection against overcurrent, overvoltage, undervoltage, overtemperature, and phase loss
	Speed tracking restart	Used to implement impact-free smooth startup for rotating motors
Peripheral interface	Terminal analog input resolution	No more than 20mV
	Terminal digital input resolution	No more than 2ms
	Analog input	Two inputs. AI1: 0(2)–10V / 0(4)–20mA; AI2: -10 – +10V
	Analog output	Two outputs. AO0/AO1: 0(2)–10V/0(4)–20mA
	Digital input	Five regular inputs. Max. frequency: 1kHz; internal impedance: 3.3kΩ One high-speed input. Max. frequency: 50kHz
	Digital output	One Y terminal open collector output, sharing the terminal with S4. The function can be selected through a jumper.
	Relay output	Two programmable relay outputs RO1A: NO; RO1B: NC; RO1C: common RO2A: NO; RO2B: NC; RO2C: common Contact capacity: 3A/AC 250V, 1A/DC 30V
Expansion interfaces	Two expansion interfaces, SLOT1 and SLOT2, supporting communication cards, I/O cards, and so on	
Other	Mounting method	Supports wall mounting, floor mounting, and flange mounting.
	Temperature of running environment	-10°C – +50°C; Derating is required when the ambient temperature exceeds 40°C. For details, see section B.2.2.1 Derating due to temperature.
	Ingress protection (IP) rating	IP20 for 1.5–200kW IP00 for 220–630kW IP21 for 710–800kW
	Pollution degree	Degree 2
	Cooling method	For 1.5kW: Natural air cooling For 2.2kW and higher: Forced air cooling

3.4 Product nameplate

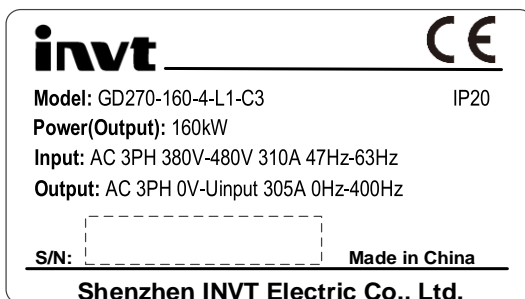

Figure 3-4 Product nameplate

Note: The preceding are standard product nameplate examples. The marking such as "CE" or "IP20" on the nameplate is marked according to actual certification conditions.

3.5 Model designation code

A model designation code contains product information. You can find the model designation code on the VFD nameplate.

GD270-160-4-L1-C3-EU

① ② ③ ④ ⑤ ⑥

Figure 3-5 Model description

Field	No.	Field description	Content
Product series abbreviation	①	Product series abbreviation	GD270: Goodrive270 series VFD for fan and pump
Rated power	②	Power range	160: 160kW
Voltage class	③	Voltage class	4: AC 3PH 380V–480V Rated voltage: 380V
Reactor configuration	④	Reactor configuration	Default: Empty L1: with built-in DC reactor for 11–630kW models; with built-in inout reactor for 710–800kW models. L3: with built-in DC reactor and output AC reactor for 220–630kW models; with built-in inout reactor and output AC reactor for 710–800kW models. Note: DC reactors are standard parts for 400–630kW models. Input reactors are standard parts for 710–800kW models.
Built-in filter configuration	⑤	Built-in filter configuration	Empty: with built-in C3 filter, applicable to 160kW–800kW

Field	No.	Field description	Content
			without built-in C3 filter, applicable to 1.5kW–132kW C2: with built-in C2 filter, applicable to 1.5kW–22kW C3: with built-in C3 filter, applicable to 30kW–132kW
Safe torque off (STO) function configuration	⑥	/	Empty: without STO function EU: with built-in STO function

3.6 Product ratings

Table 3-1 Ratings for AC 3PH 380V models

VFD model	Output power (kW)	Input current (A)	Output current (A)
GD270-1R5-4(-C2)(-EU)	1.5	5	3.7
GD270-2R2-4(-C2)(-EU)	2.2	6	5
GD270-004-4(-C2)(-EU)	4	15	9.5
GD270-5R5-4(-C2)(-EU)	5.5	20	13
GD270-7R5-4(-C2)(-EU)	7.5	27	17
GD270-011-4(-L1/-C2)(-EU)	11	35 (35)	25
GD270-015-4(-L1/-C2)(-EU)	15	44 (44)	32
GD270-018-4(-L1/-C2)(-EU)	18.5	46 (46)	38
GD270-022-4(-L1/-C2)(-EU)	22	54 (54)	45
GD270-030-4(-L1)(-C3)(-EU)	30	75 (56)	60
GD270-037-4(-L1)(-C3)(-EU)	37	90 (69)	75
GD270-045-4(-L1)(-C3)(-EU)	45	108 (101)	92
GD270-055-4(-L1)(-C3)(-EU)	55	142 (117)	115
GD270-075-4(-L1)(-C3)(-EU)	75	177 (149)	150
GD270-090-4(-L1)(-C3)(-EU)	90	200 (171)	180
GD270-110-4(-L1)(-C3)(-EU)	110	240 (205)	215
GD270-132-4(-L1)(-C3)(-EU)	132	278 (235)	250
GD270-160-4(-L1)(-EU)	160	310 (296)	305
GD270-185-4(-L1)(-EU)	185	335 (320)	330
GD270-200-4(-L1)(-EU)	200	385 (368)	380
GD270-220-4(-Ln)(-EU)	220	430 (411)	425
GD270-250-4(-Ln)(-EU)	250	465 (444)	460
GD270-280-4(-Ln)(-EU)	280	540 (485)	530
GD270-315-4(-Ln)(-EU)	315	605 (550)	600
GD270-355-4(-Ln)(-EU)	355	655 (600)	650
GD270-400-4-Ln(-EU)	400	660	720
GD270-450-4-Ln(-EU)	450	745	820

VFD model	Output power (kW)	Input current (A)	Output current (A)
GD270-500-4-Ln(-EU)	500	800	860
GD270-560-4-Ln(-EU)	560	970	1020
GD270-630-4-Ln(-EU)	630	1100	1120
GD270-710-4-Ln(-EU)	710	1200	1260
GD270-800-4-Ln(-EU)	800	1320	1460

Note:

- ◇ $n = 1$ or 3 .
- ◇ The parentheses "()" in the "VFD model" column are used to distinguish models when selecting different product configurations. Please note that 11–22kW models can only be configured with one from the built-in DC reactor (L1) and the built-in C2 filter.
- ◇ The rated output current is the output current when the output voltage is 380V.
- ◇ The data in the "Input current" column are measured at an input voltage of 380V. The data in "()" are measured when a DCor input reactor is configured.

3.7 Product heat dissipation

VFD model	Entire machine full load power dissipation (W)	Heat dissipation (BTU/hr)	Air volume (m ³ /h)	Air volume (ft ³ /min(CFM))
GD270-1R5-4(-C2)(-EU)	48	164	/	/
GD270-2R2-4(-C2)(-EU)	60	205	35	21
GD270-004-4(-C2)(-EU)	125	427	52	30
GD270-5R5-4(-C2)(-EU)	180	614	64	38
GD270-7R5-4(-C2)(-EU)	220	751		
GD270-011-4(-L1/-C2)(-EU)	320	1092	105	61
GD270-015-4(-L1/-C2)(-EU)	385	1314		
GD270-018-4(-L1/-C2)(-EU)	460	1513	120	68
GD270-022-4(-L1/-C2)(-EU)	520	1696		
GD270-030-4(-L1)(-C3)(-EU)	768	2620	140	83
GD270-037-4(-L1)(-C3)(-EU)	960	3276		
GD270-045-4(-L1)(-C3)(-EU)	1090	3719	290	171
GD270-055-4(-C3)(-EU)	1837	6268	500	295
GD270-055-4-L1(-C3)(-EU)	1330	4538		
GD270-075-4(-C3)(-EU)	2400	8189		
GD270-075-4-L1(-C3)(-EU)	1753	5981		
GD270-090-4(-C3)(-EU)	2880	9827		
GD270-090-4-L1(-C3)(-EU)	2082	7104		

VFD model	Entire machine full load power dissipation (W)	Heat dissipation (BTU/hr)	Air volume (m ³ /h)	Air volume (ft ³ /min(CFM))
GD270-110-4(-C3)(-EU)	2490	8496	670	394
GD270-110-4-L1(-C3)(-EU)	2114	7213		
GD270-132-4(-C3)(-EU)	2780	9485		
GD270-132-4-L1(-C3)(-EU)	2360	8052		
GD270-160-4(-EU)	2648	9035	1120	657
GD270-160-4-L1(-EU)	2890	9861		
GD270-185-4(-EU)	2898	9888		
GD270-185-4-L1(-EU)	3140	10714		
GD270-200-4(-EU)	3453	11782	1360	800
GD270-200-4-L1(-EU)	3692	12597		
GD270-220-4(-EU)	3911	13344	1330	785
GD270-220-4-L1(-EU)	4547	15514		
GD270-220-4-L3(-EU)	4547	15514		
GD270-250-4(-EU)	4393	14989		
GD270-250-4-L1(-EU)	5026	17149		
GD270-250-4-L3(-EU)	5026	17149		
GD270-280-4(-EU)	5136	17524	2160	1270
GD270-280-4-L1(-EU)	5649	19274		
GD270-280-4-L3(-EU)	5649	19274		
GD270-315-4(-EU)	5814	19837		
GD270-315-4-L1(-EU)	6395	21820		
GD270-315-4-L3(-EU)	6395	21820		
GD270-355-4(-EU)	6299	21492		
GD270-355-4-L1(-EU)	6928	23638		
GD270-355-4-L3(-EU)	6928	23638		
GD270-400-4-L1(-EU)	6976	23802		
GD270-400-4-L3(-EU)	7674	26184		
GD270-450-4-L1(-EU)	7946	27112		
GD270-450-4-L3(-EU)	8740	29821		
GD270-500-4-L1(-EU)	8333	28432		
GD270-500-4-L3(-EU)	9166	31274		
GD270-560-4-L1(-EU)	9122	31104	2320	1365
GD270-560-4-L3(-EU)	9732	33206		
GD270-630-4-L1(-EU)	11028	37628		
GD270-630-4-L3(-EU)	11408	38924		

VFD model	Entire machine full load power dissipation (W)	Heat dissipation (BTU/hr)	Air volume (m ³ /h)	Air volume (ft ³ /min(CFM))
GD270-710-4-L1(-EU)	11054	37716	4141	2436
GD270-710-4-L3(-EU)	11689	39883		
GD270-800-4-L1(-EU)	12950	44185		
GD270-800-4-L3(-EU)	13585	46352		

3.8 Structure

The VFD structure is shown in the following figure (taking the 380V 45kW VFD model as an example).

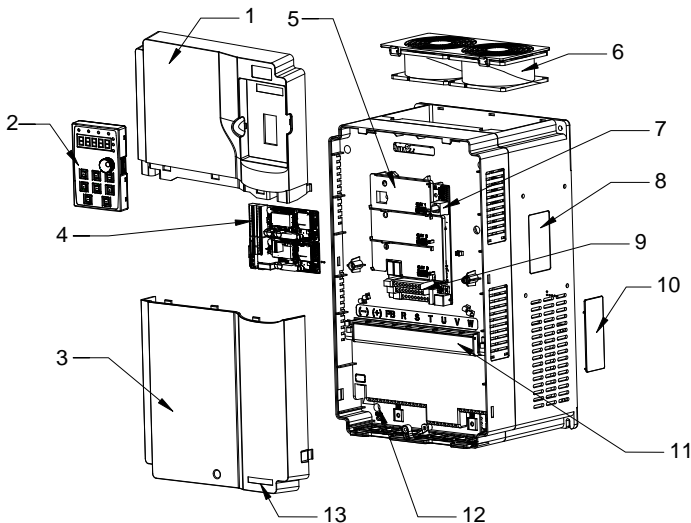

No.	Name	Description
1	Upper cover	Protects internal components and parts.
2	Keypad	See section 5.2 Operation procedure.
3	Lower cover	Protects internal components and parts.
4	Expansion card	Optional. For details, see Appendix A Expansion card.
5	Baffle of control board	Protects the control board and install extension card.
6	Cooling fan	See section 8 Maintenance.
7	Keypad interface	Connects the keypad.
8	Nameplate	See section 3 Product overview.
9	Control terminals	See section 4.3.4 Wiring of basic control circuit

No.	Name	Description
10	Cover plate of heat emission hole	Optional. Cover plate can upgrade protection level, however, as it will also increase internal temperature, derated use is required.
11	Main circuit terminals	See section 4.3.2 Main circuit terminals
12	POWER indicator	Power supply indicator
13	GD270 product series label	See section 3.5 Model designation code.

The following figure shows the structural layout of the 710–800 kW VFDs (using GD270-800-4-L3 as an example).

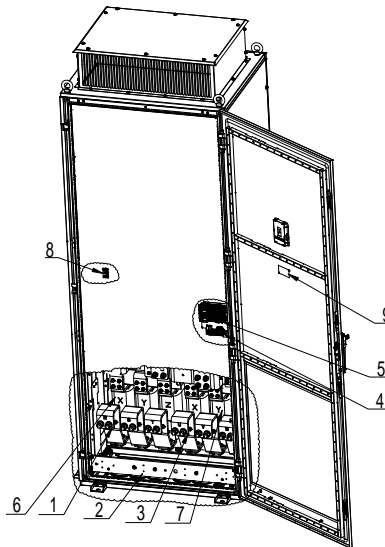

No.	Name	Description
1	3PH input bar	Wiring of RST 3PH cables
2	Grounding bar	System grounding
3	3PH output bar	Wiring of UVW 3PH cables
4	Control board	Protects the control board and install extension card.
5	Expansion card	Optional. For details, see Appendix A Expansion card.
6	Input reactor	Device that restricts the electromagnetic interference generated by the VFD and transmitted to the public grid through the power cable.
7	Output reactor	Device used to suppress interference generated from the wiring on the output side of the VFD.

No.	Name	Description
8	POWER indicator	Power supply indicator
9	Nameplate	See chapter 3 Product overview.

4 Installation guidelines

4.1 What this chapter contains

This chapter describes the mechanical installation and electrical installation of the VFD.

	<ul style="list-style-type: none"> ✧ Only trained and qualified professionals are allowed to carry out the operations mentioned in this chapter. Please carry out operations according to instructions presented in chapter 1 Safety precautions. Ignoring these safety precautions may lead to physical injury or death, or device damage. ✧ Ensure the VFD power has been disconnected before installation. If the VFD has been powered on, disconnect the VFD power and wait for at least the time specified on the VFD, and ensure the POWER indicator is off. You are recommended to use a multimeter to check and ensure the VFD DC bus voltage is below 36V. ✧ The VFD installation must be designed and done according to applicable local laws and regulations. INVT does not assume any liability whatsoever for any VFD installation which breaches local laws or regulations. If recommendations given by INVT are not followed, the VFD may experience problems that the warranty does not cover.
---	---

4.2 Mechanical installation

4.2.1 Installation environment

The installation environment is essential for the VFD to operate with best performance in the long run. Install the VFD in an environment that meets the following requirements.

Environment	Condition
Installation site	Indoor
Ambient temperature	<ul style="list-style-type: none"> ✧ -10—+50°C. ✧ When the ambient temperature exceeds 40°C, derate by 1% for every increase of 1°C. ✧ Do not use the VFD when the ambient temperature exceeds 50°C. ✧ To improve reliability, do not use the VFD in the places where the temperature changes rapidly. ✧ When the VFD is used in a closed space, such as control cabinet, use a cooling fan or air conditioner for cooling, preventing the internal temperature from exceeding the temperature required. ✧ When the temperature is too low, if you want to use the VFD that has been idled for a long time, install an external heating device before the use to eliminate the freeze inside the VFD. Otherwise, the VFD may be damaged.

Environment	Condition
Relative humidity (RH)	<ul style="list-style-type: none"> ✧ Less than 90% ✧ Condensation is not allowed. ✧ The max. RH cannot exceed 60% in the environment where there are corrosive gases.
Storage temperature	-30—+60.0°C
Running environment	Install the VFD in a place: <ul style="list-style-type: none"> ✧ Away from electromagnetic radiation sources ✧ Away from oil mist, corrosive gases, and combustible gases ✧ Without the chance for foreign objects such as metal powder, dust, oil and water to fall into the VFD (do not install the VFD onto combustible objects such as wood) ✧ Without radioactive substances and combustible objects ✧ Without hazard gases or liquids ✧ With low salt content ✧ Without direct sunlight
Altitude	<ul style="list-style-type: none"> ✧ Lower than 1000m ✧ When the altitude exceeds 1000m, derate by 1% for every increase of 100m.
Vibration	The max. amplitude of vibration cannot exceed 5.8m/s ² (0.6g).
Installation direction	Install the VFD vertically to ensure good heat dissipation performance.

4.2.2 Mounting method

The VFD can be installed on the wall or in a cabinet.

The VFD must be installed vertically. Check the installation position according to following requirements. For details about the outline dimensions, see Appendix C Dimension drawings.

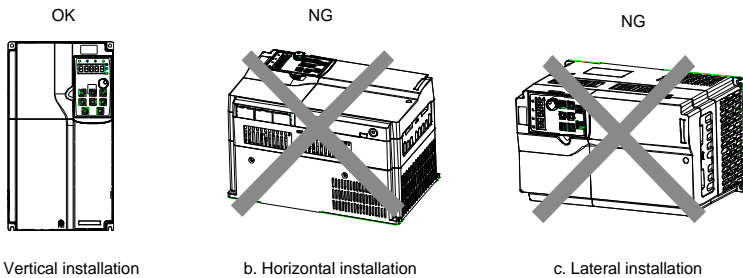

Figure 4-1 Installation direction

The VFD mounting method varies depending on the size.

VFD power	Wall mounting	Flange mounting	Floor mounting
1.5–200kW	✓	✓	/
220–250kW	✓	/	✓
280–800kW	/	/	✓

Note: "✓" indicates that the installation method is applicable, while "/" indicates that it is not applicable.

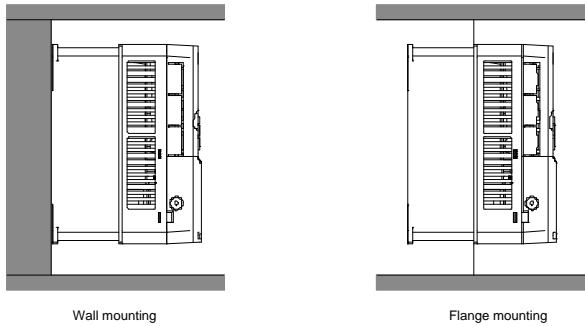

Figure 4-2 Mounting method

The installation procedure is as follows:

- Step 1 Mark the installation hole positions. For details about the installation hole positions, see Appendix C Dimension drawings.
- Step 2 Secure the screws or bolts to the marked position.
- Step 3 Lean the VFD against the wall.
- Step 4 Tighten the fastening screws on the wall.

Note: The flange mounting plate must be used for flange mounting.

4.2.3 Cabinet design

4.2.3.1 Cabinet design for 1.5–200kW

■ Space requirements inside the cabinet

For 1.5–200kW models, multi-layer installation is recommended. The minimum clearance required between layers is listed in the following table. A heat insulation deflector must be installed above the lower layer VFD.

Table 4-1 Minimum space for multi-layer installations

Power range	1.5–22kW	30–90kW	110–200kW
D1	≥100mm	≥200mm	≥300mm

Power range	1.5–22kW	30–90kW	110–200kW
D2	≥100mm	≥200mm	≥300mm
...	≥100mm	≥200mm	≥300mm
Dn	≥100mm	≥200mm	≥300mm
D (side-by-side installation space)	≥30mm	≥50mm	≥100mm

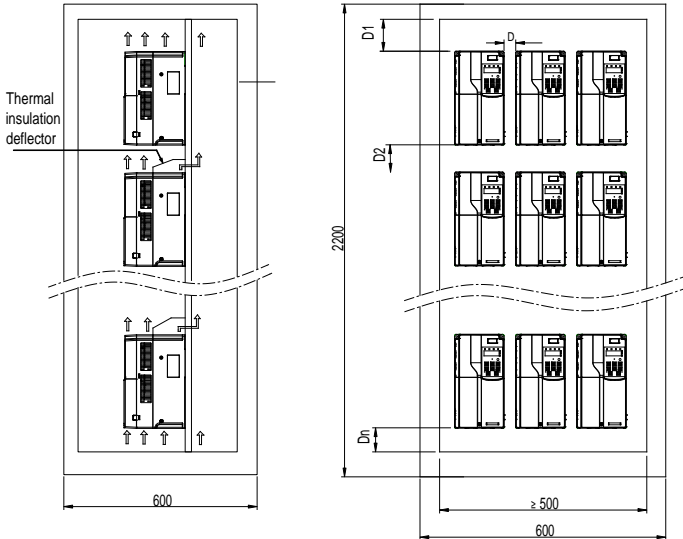

Figure 4-3 Multi-layer installation space requirements

■ **Installation backplane requirements**

To ensure that the VFD is installed and operated with good reliability, the following are detailed instructions regarding the thickness and rigidity reinforcement requirements of the backplate.

- ◇ In practical applications, the VFD may generate vibrations and thermal expansion during operation, so the backplate needs to have sufficient rigidity to withstand environmental and working conditions.
- ◇ The thickness of the backplate should be ≥2mm, which provides the necessary basic rigidity to prevent deformation or damage during equipment operation.
- ◇ The backplate can be reinforced if necessary. It is recommended to weld a transverse reinforcement beam on the back of the backplate (as shown in Figure 4-4). This can significantly improve the load-bearing capacity of the backplate and enhance the overall structural stability.
- ◇ When installing the VFD, ensure that the connection between the backplate and the cabinet is

secure to reduce vibration transmission.

- ◇ Considering that the VFD will generate heat during operation, sufficient heat dissipation space should be left in the backplate design to avoid overheating.
- ◇ Regularly inspect the condition of the backplate to ensure there is no deformation or damage. If any issues are found, reinforcement or replacement should be carried out promptly.

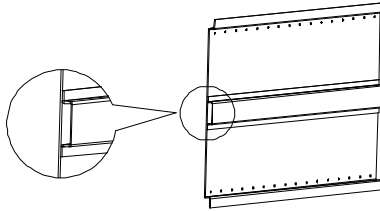

Figure 4-4 Weld a transverse reinforcement beam on the back of the backplane.

■ Heat dissipation description

The VFD dissipates heat through built-in fans (1.5kW models rely on natural cooling). To ensure sufficient cooling air enters the cabinet, an adequately large air intake should be opened on the cabinet door panel.

The air intake on the cabinet door panel should be positioned at least 50mm below the air intake of the VFD. This utilizes the natural upward flow of cold air to ensure it can smoothly enter the cabinet.

When installing the fan, pay attention to the airflow direction to ensure the fan extracts air from inside the cabinet to the outside. This effectively discharges the hot air from inside the cabinet, preventing heat buildup that could cause the VFD to overheat or be damaged. The distance between the exhaust cover and the fan outlet should be $\geq 200\text{mm}$, otherwise, it will affect the heat dissipation performance of the fan. Ensure that air can flow freely to avoid air blockage.

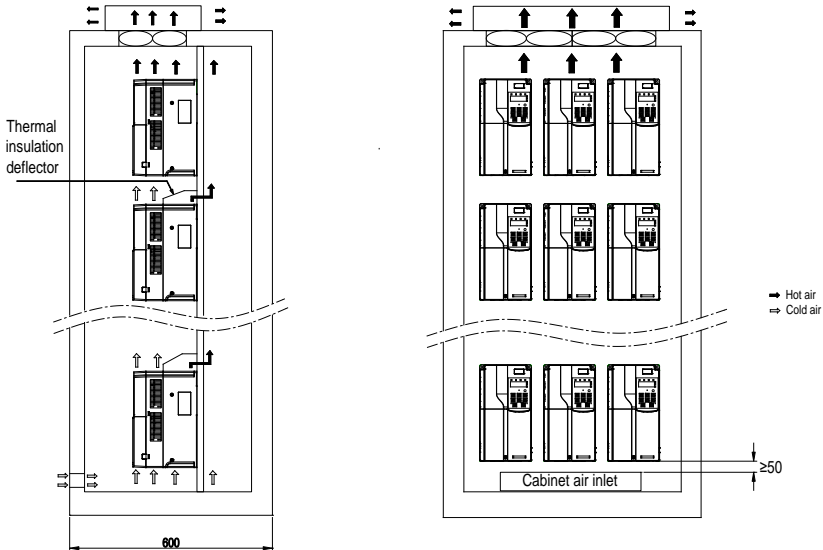

Figure 4-5 Cabinet air intake opening position

Note: In cases where multiple devices are installed in the same cabinet, using a fan to blow air into the cabinet intake can cause airflow distribution issues, affecting overall heat dissipation. Therefore, fans should not be installed at the cabinet intake to blow air inward.

After the VFD is installed in the cabinet, the minimum effective area of the air intake is shown in Table 4-2.

The data in Table 4-2 is only for a single VFD. When there are multiple VFDs in the cabinet, the total air intake area should be the sum of the individual areas. For example, if there are 10 units of 5.5kW and 2 units of 15kW, the minimum effective air intake area of the cabinet should be $10 \times 44 + 2 \times 58 = 556 \text{cm}^2$.

If the air intake is equipped with a filter, it will cause air resistance. It is recommended to multiply the given air intake area by 1.2–1.5 times during design. The values in Table 4-2 is the minimum effective air intake area of the cabinet. If the design area is smaller than the specified effective area, the cabinet may experience negative pressure, preventing proper airflow and heat dissipation as intended.

1. Passive cooling

Passive cooling utilizes the natural upward flow of hot air, directing the exhaust from the VFD out of the cabinet through the top vent. However, passive exhaust can lead to the accumulation of hot air in the upper part of the cabinet, increasing the temperature in that area. The suction effect of the VFD's fan will create a relatively low pressure at the air intake, resulting in a pressure difference between the

exhaust and intake vents inside the cabinet. This pressure difference will cause hot air to circulate inside the cabinet, forming a closed loop.

If hot air continuously flows back to the air intake, the VFD will repeatedly inhale this hot air, significantly increasing the internal temperature. This is undoubtedly detrimental to the device's performance and lifespan. Therefore, to improve the performance of the passive exhaust system, isolation devices must be used to prevent hot air from recirculating.

Isolation devices can be made of plates or exhaust ducts, as shown in Figure 4-6. Inside the cabinet, isolation panels can be used to separate the exhaust and intake areas, effectively reducing the likelihood of hot air recirculation. Additionally, installing dedicated exhaust ducts to guide hot air outside further isolates the flow of cold and hot air, achieving more effective heat dissipation.

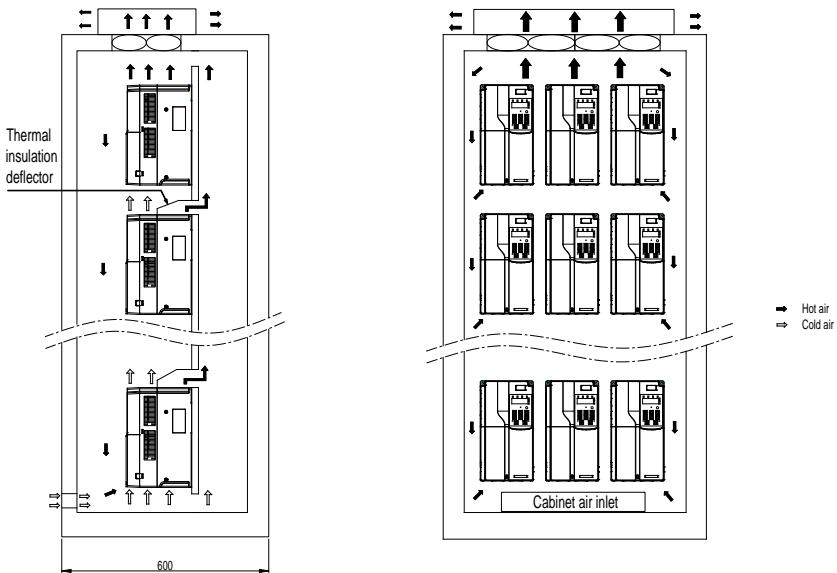

Figure 4-6 Recirculation of hot air in a passive exhaust cabinet (without isolation device)

The exhaust vent of the VFD has a higher temperature and lower air density compared to the intake vent. To ensure hot air is effectively expelled from the cabinet in a passive cooling system, refer to Table 4-2 for the minimum effective area of the cabinet's exhaust vent.

The data in Table 4-2 is only for a single VFD. When there are multiple VFDs in the cabinet, the total air exhaust area should be the sum of the individual areas. If the exhaust vent is equipped with a filter, it will cause air resistance. It is recommended to multiply the reference area value by 1.2–1.5 times during design.

2. Active cooling

Active cooling involves installing fans at the top of the cabinet to extract hot air from the cabinet to the

outside. Active exhaust is a commonly used exhaust method. To ensure that hot air inside the cabinet can be effectively expelled, the total airflow of the system fans must not be less than the sum of the airflow of all VFDs in the cabinet. The required cooling airflow is shown in the following table.

Table 4-2 Heat dissipation parameters of 1.5–200kW cabinet

Steps for selecting cabinet fans:

Step 1 Calculate the total cooling airflow required for all VFDs based on the table above.

Step 2 Determine the maximum airflow value of the cabinet fans and select the appropriate fan specifications and quantity.

- Under normal conditions, the maximum airflow value of the cabinet is recommended to be 1.3–1.5 times the calculated value.
- When the cabinet exhaust vent is equipped with components such as mesh or louvers, which may increase air resistance, it is recommended to multiply the calculated value by 1.8–2.2 times.

Step 3 The airflow of the selected fan is not less than the maximum airflow, and multiple fans can be used when a single fan cannot meet the requirement.

4.2.3.2 Cabinet design for 220–630kW

220–630kW models (L1, L3) can be mounted in cabinets. Heat dissipation must be considered for the cabinet mounting method. Both active cooling and passive cooling solutions can be considered.

1. Passive cooling

When using a passive cooling solution, ensure that the top exhaust area of the cabinet and the air intake area of the cabinet are greater than the values given in Table 4-3. If there are components such as dust filters or louvers, consider increasing the air intake and exhaust areas by 1.3–1.5 times.

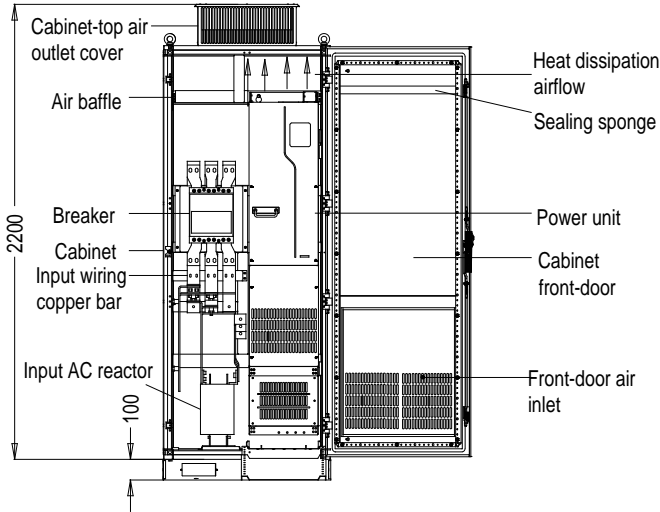

Figure 4-7 Direct exhaust cabinet (without a fan at the top)

Table 4-3 Passive cooling parameters

VFD power	VFD cooling air volume (CFM)	Minimum actual effective area of the air intake (mm ²)	Minimum actual effective area of the exhaust vent (mm ²)
220–250kW	785	172560	37280
280–355kW	1270	200670	42800
400–630kW	1270	259000	50230

Note:

- 1CFM=1.7m³/h .
- The term "actual effective area" mentioned above refers to the through-hole area. In practical design, the cut-out rate must be considered.
- Passive cooling is not suitable for 560–630 kW models.

2. Active cooling

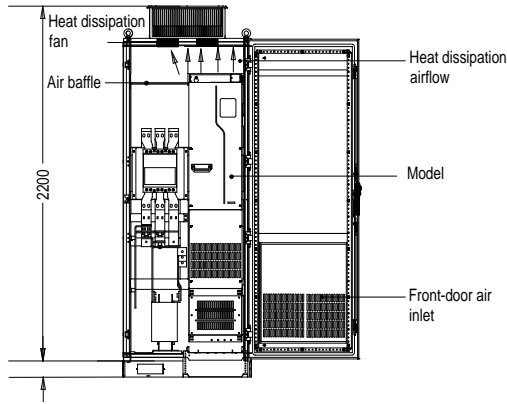

Figure 4-8 Top fan exhaust cabinet

Table 4-4 Active cooling parameters

VFD power	VFD cooling air volume (CFM)	Minimum actual effective area of the air intake (mm ²)	Air volume requirement (CFM)	Actual effective area of top exhaust vent (mm ²)
220–250kW	785	172560	864	≥Total ventilation area of the selected fans
280–355kW	1270	200670	1400	
400–500kW	1270	200670	1400	
560–630kW	1356	259000	1492	

Note: 1CFM≈1.7m³/h.

As shown in Figure 4-9, the air duct of VFD must be isolated within the cabinet to prevent the hot air in the VFD outlet from circulating within the cabinet, and the air baffle design for isolation ensures that the hot air is discharged from the cooling holes at the top of cabinet.

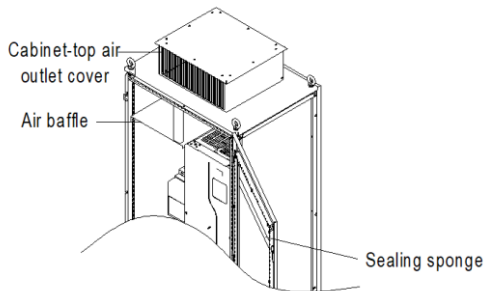

Figure 4-9 Air baffle design

Note: A 40x40 sealing sponge must be used at the position corresponding to the air baffle in the front door panel, which prevents air duct short circuit.

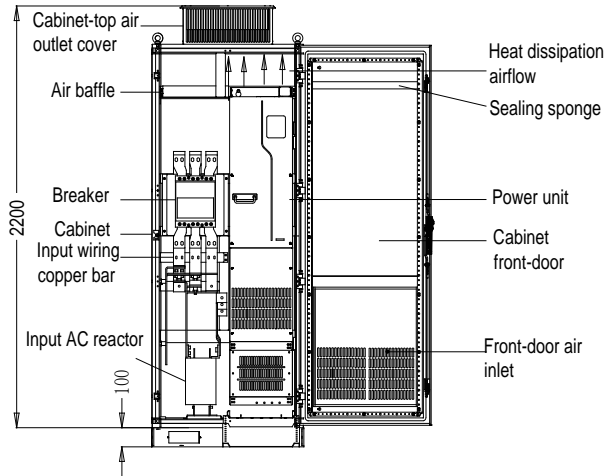

Figure 4-10 Recommended cabinet layout for 220–630kW models

■ **In-cabinet mounting procedure**

No.	Description
1	Mount the crossbeam for VFD fixing in the nine-fold profile cabinet. (See Figure 4-11.)
2	Fix the bottom support crossbeams and mounting bracket in the cabinet. (See Figure 4-13.)
3	Assemble the mounting rail (optional part) and mount it in the cabinet.
4	Arrange two people to align the VFD casters with the mounting rail and push the VFD to the cabinet. (See Figure 4-15 and Figure 4-16. Use the auxiliary rope for mounting to prevent the VFD from side tipping during the push-in or push-out, as shown in Figure 4-17.)
5	Remove the auxiliary rope for mounting, and insert screws into the fixing holes at the back, top, and bottom of VFD to fix the VFD to the mounting crossbeam. (See Figure 4-18.)
6	Removed the mounting rail when you ensure the mounting is secure.

1. Fix the mounting crossbeam and reserve fixing holes.
 - A. The nine-fold profile cabinet (PS cabinet) is recommended. Figure 4-11 shows the nine-fold profile cross section.
 - B. When mounting a GD270 series 280–630kW VFD into a nine-fold profile cabinet with the depth of 600mm, you must bend the mounting crossbeam inwards (shown in Figure 4-12) to make use of

the space of column, which is not necessary for the mounting into a standard cabinet with the depth of 800mm or greater.

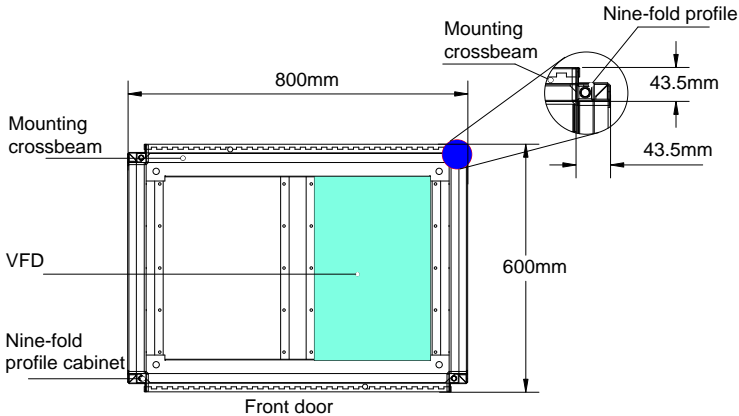

Figure 4-11 Top view of mounting a 280–630kW VFD in a cabinet

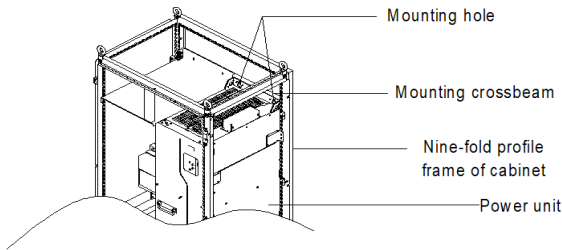

Figure 4-12 Three-dimension view of mounting a 280–630kW VFD in a cabinet

2. Fix the bottom support crossbeams and mounting bracket. See Figure 4-13.
 - A. Use eight M8 cage nuts to fix the two bottom support crossbeams to the base of the nine-fold profile cabinet frame. (The support crossbeams are user designed, $T \geq 2.5\text{mm}$, firmly installed.)
 - B. Fix the mounting bracket to the nine-fold profile cabinet frame base with six M5 self-tapping screws, as shown in the following figure. For details about mounting bracket dimensions, see Figure 4-15 and Table C-8.
 - C. If you use another type of cabinet but not nine-fold profile cabinet, the fixing holes for the mounting bracket need to be drilled and assembled on site.

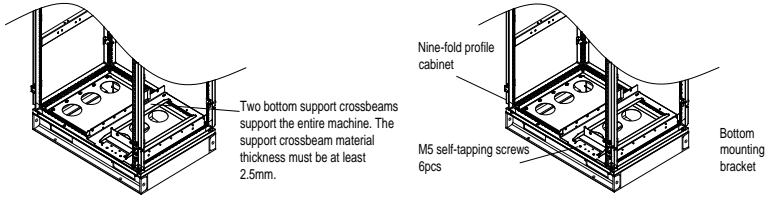

Figure 4-13 Bottom bracket mounting

3. Assemble the mounting rail (optional part).

Assemble the mounting rail, align the two front hooks with the nine-fold profile notch, and snap them into place.

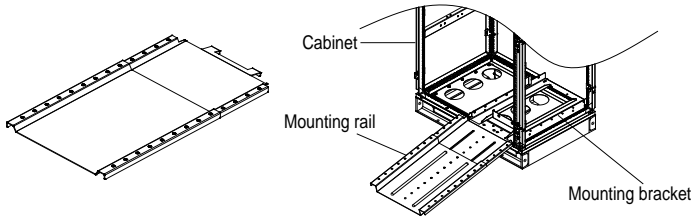

Figure 4-14 Mounting rail

4. Push the VFD into the cabinet.

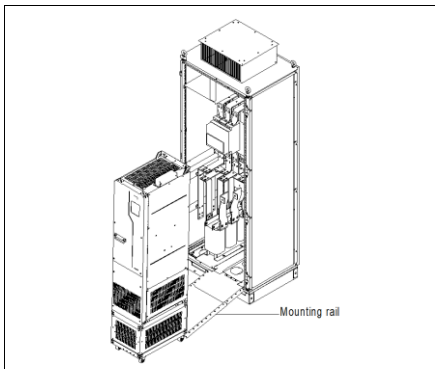

Figure 4-15 Aligning the VFD casters with the mounting rail

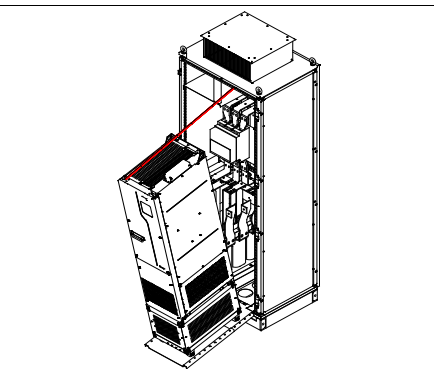

Figure 4-16 Pushing the VFD into the cabinet slowly

Note: Since the VFD barycenter is too high, use the auxiliary rope for mounting to prevent the VFD from rollover during the push-in or push-out. See Figure 4-17.

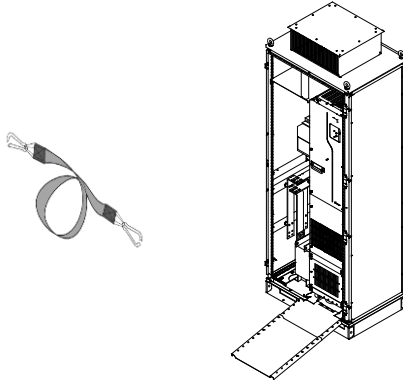

Figure 4-17 VFD already in the cabinet

5. Remove the mounting rail.

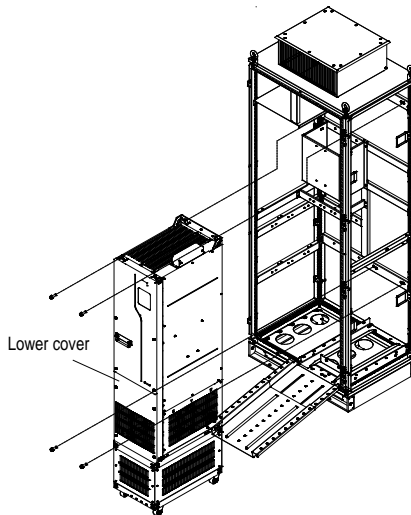
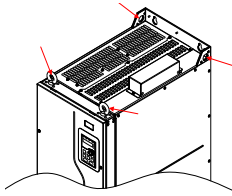
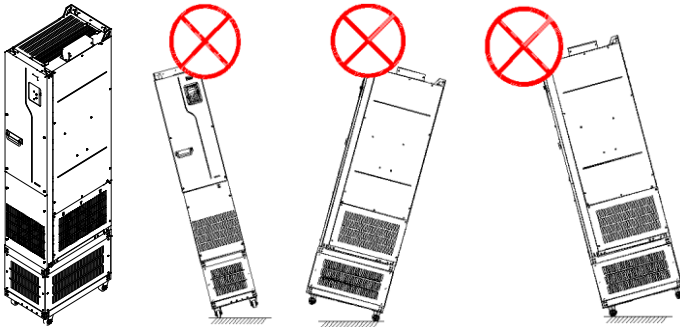

Figure 4-18 Fixing the VFD to the cabinet crossbeam through the four fixing holes at the VFD back

6. Pay attention to the following:
 - A. Detach the VFD from the cabinet by following the preceding procedure in reverse sequence.
 - B. When fixing the VFD, ensure that the four mounting holes of VFD have been securely connected to the mounting crossbeam.
 - C. Use the lifting ring on the top of VFD for lifting and moving. Never apply force to the positive and negative bus terminals.



D. If you need to place the VFD vertically, avoid applying force to VFD sides or placing the VFD on a tilted surface. If the tilted angle is more than 5°, the VFD may suffer rollover since the VFD has a large size and heavy weight (about 200kg).

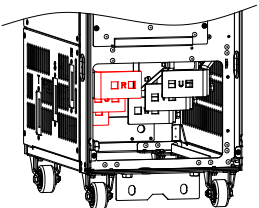
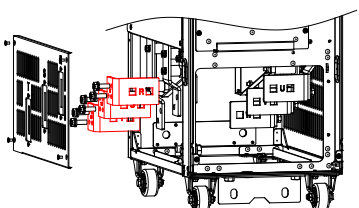
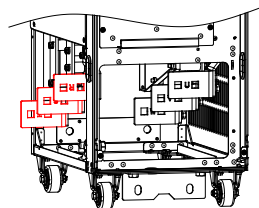
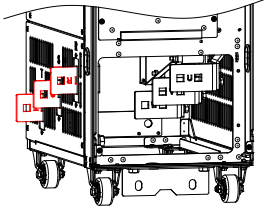

4.2.4 Installation instructions for reverse connection of input aluminum bars

<p>① Aluminum bars are installed inside the entire machine.</p> 	<p>② Disassemble the side cover plate and input aluminum busbars.</p> 
<p>③ Reversely install the input aluminum bars.</p> 	<p>④ Install the side cover plate.</p> 

4.2.5 Top cardboard removal instructions

When installing 220–630kW VFDs, keep the cardboard fixed above the VFD to prevent conductive foreign objects from falling into the VFD during installation. After the VFD installation is completed, the cardboard must be removed before power-on. The position of the cardboard is shown in the figure below.

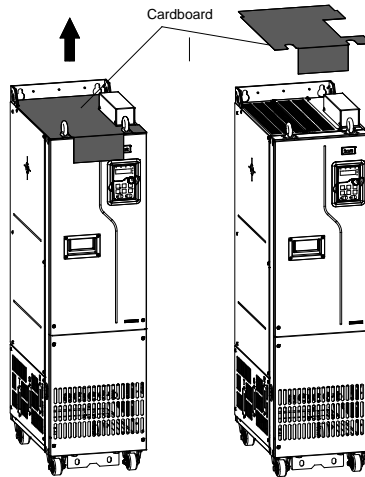

4.2.6 VFD cabinet installation

4.2.6.1 Transportation

When transported with a forklift, the VFD must be fixed to the pallets and transported together, which means you are not allowed to remove the pallets to transport the VFD alone.

If the forklift's fork tines are too short, it may cause the unit/cabinet to tip over, resulting in serious injury, property damage or even death.

When transported with a crane, the VFD must be fixed to the pallets and lifted together.

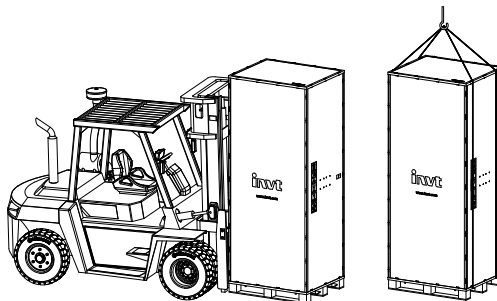

The VFD cabinet is shipped in a wooden box with pallets, which are heavy as a whole and must be carried with a lifting tool, such as a forklift and crane. Operators must be professionally trained. The product must be transported in strict accordance with the allowed ways marked on the box, and not allowed to be transported upside down or on the sides.

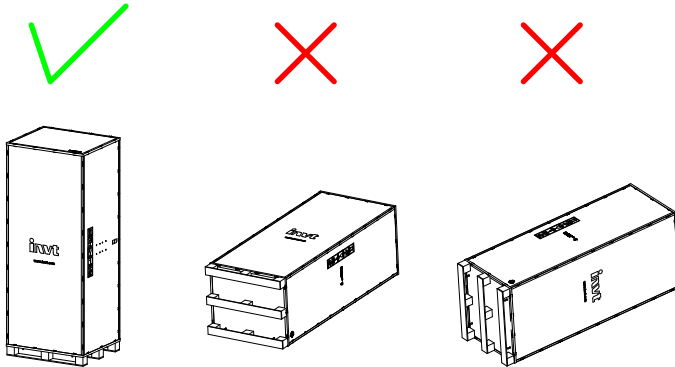

To lift and handle the device from the top, pass the lifting rope or sling through the lifting rings and secure it properly. Proceed with the lifting operation only after ensuring safety.

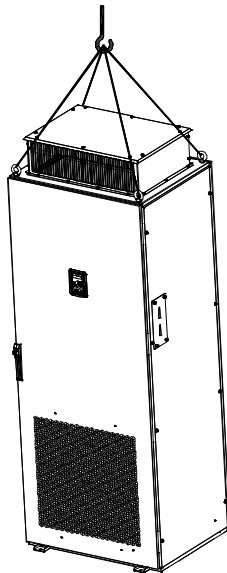

If the VFD is to be installed in a cabinet, the center of gravity of the entire cabinet must be considered during transportation. The VFD is heavy and will significantly affect the cabinet's overall weight distribution. When lifting and moving the cabinet with the VFD installed, ensure that the center of

gravity is positioned directly below the vertical line of the lifting equipment to prevent the cabinet from tipping over during the hoisting process.

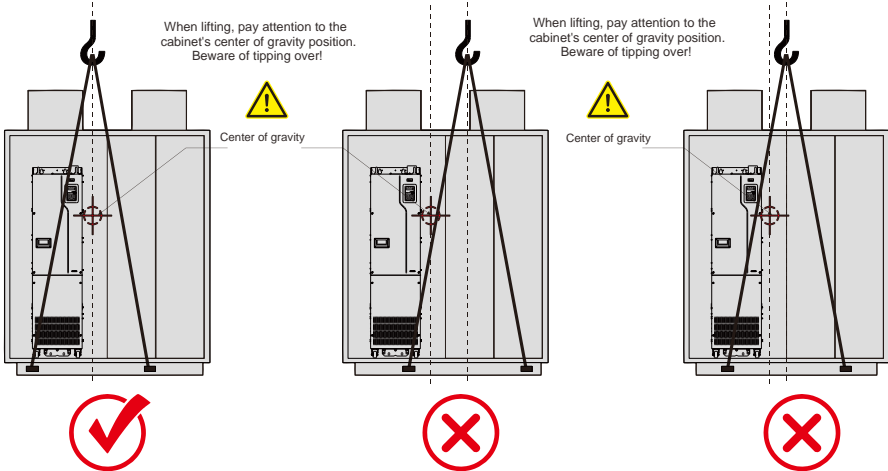

4.2.6.2 Unpacking

The cabinet is delivered in the wooden box padded with EPE.

To remove the packing, do as follows:

- Step 1 Place the well-packed unit in an empty and flat place.
- Step 2 Use tools such as a pry bar or large one-piece screwdriver to remove the wooden box cover and the steel tongue nails of the surrounding boards.
- Step 3 Remove the surrounding boards and EPE filling materials from the wooden box.
- Step 4 Cut off the plastic wrapping tape around the cabinet.
- Step 5 Take out the cabinet and confirm that the cabinet is intact without any damage.
- Step 6 Dispose of or recycle packaging in accordance with local regulations.

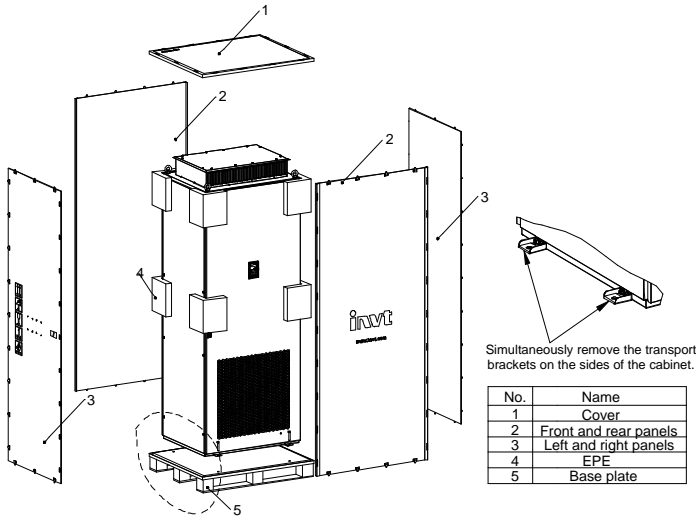

4.2.6.3 Installation site check

The installation site should be well ventilated or shaded for good heat dissipation.

The installation environment meets the specification requirements.

The wall/material near the installation site should be non-combustible material.

The floor should be made of non-combustible material, and flat and strong to withstand the weight of the equipment. Check the level of the floor with a level, and ensure that the maximum allowable deviation of the level of the ground surface is 5mm per 3m. The installation site should be leveled if necessary, as the cabinet is not equipped with adjustable feet.

For ease of maintenance, do not install the cabinet at a higher position than the area in front of it.

4.2.6.4 Installation instructions

The cabinet is floor mounted and fixed to the ground.

When the channel steel base is not available on the site, fix the cabinet directly to the ground through 4 fixing anchor bolts. The following figure shows the installation dimensions (unit: mm).

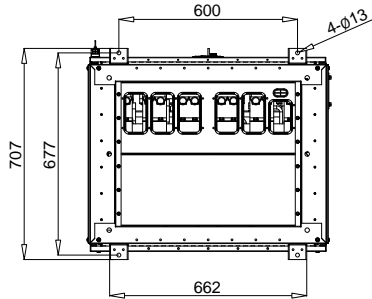

When the channel steel base is available on the site, fix the channel steel base with the ground, and then use bolts to fix the cabinet to the base through the mounting holes. The following figure shows the installation dimensions (unit: mm).

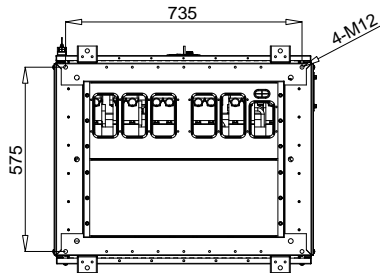

4.2.6.5 Requirements for the foundation

The cabinet must be installed on a level and solid foundation that can support the weight of the equipment. When opening and closing the cabinet doors, proper operation of the door locks must be ensured. When connecting multiple cabinets side by side, make sure there are no gaps between the cabinets and the floor.

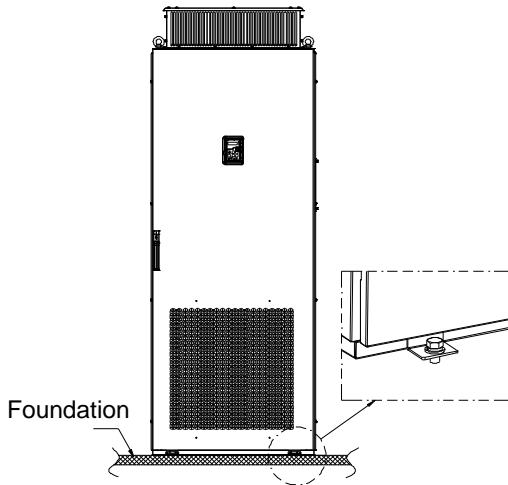

The installation procedure is as follows:

- Step 1 Mark the installation hole positions. For details about the installation hole positions, see section C.4 Product dimensions.
- Step 2 Align the mounting holes and position the VFD on the foundation.
- Step 3 Mount the bolts into the marked positions.
- Step 4 Tighten the bolts securely.

Installation tools:

No.	Tool name	Description
1	Crane	Used to lift the VFD onto the foundation
2	Socket wrench	Used to tighten bolts
3	M12*30 bolt + spring & flat washer	/

4.2.6.6 Installation space

To ensure reliable cabinet installation and good heat dissipation, the ventilation clearances must be kept from the front, back, top and sides of the cabinet. For the minimum clearance, see the following figure.

A minimum clearance of 800mm should be reserved in front of the cabinet to facilitate cabinet maintenance.

Violation of the requirements in the installation space and heat dissipation will shorten the VFD life and may result in VFD failure or malfunction.

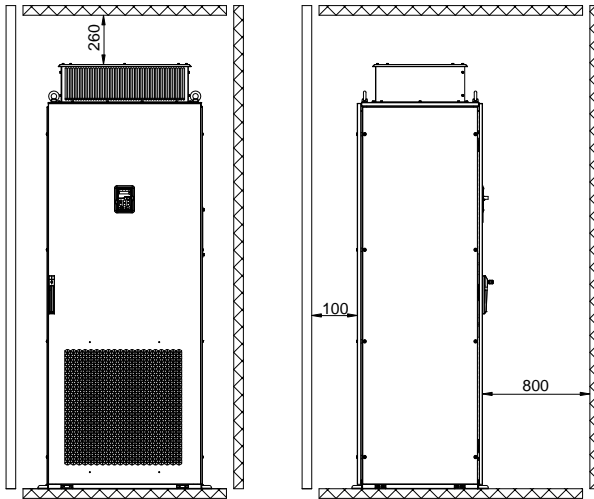

4.2.6.7 External braking resistor cabinet or braking unit connection (710–800kW)

Procedure:

- Step 1 Open the cabinet door and install the external braking unit adapter busbar as shown in Figure 4-19
- Step 2 Connect the external braking unit as shown in Figure 4-20.

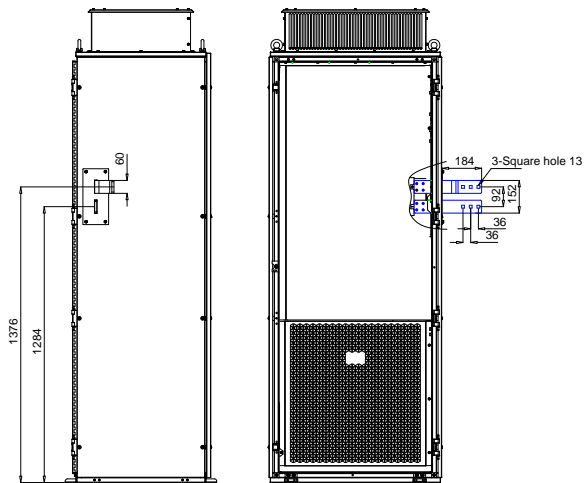

Figure 4-19 Mounting dimensions of adapter busbar (unit: mm)

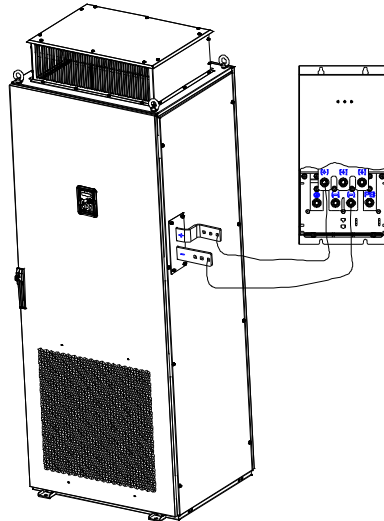

Figure 4-20 Connection diagram between VFD and external braking unit

4.3 Electrical installation

4.3.1 Main circuit wiring

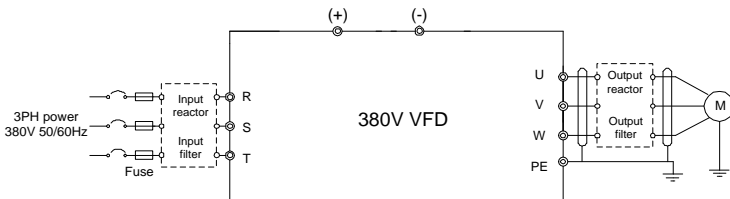

Figure 4-21 AC 3PH 380V VFD main circuit wiring

Note:

- ◇ The fuse, input reactor, input filter, output reactor, and output filter are optional parts. For details, see Appendix D Optional peripheral accessories.
- ◇ If you require the built-in DC reactor, purchase the VFD model with the suffix "-L1".

4.3.1.1 Length requirements of motor cables

When the distance between the VFD and the motor is too long, the large parasitic capacitance to ground produces high harmonic current, which causes the VFD to frequently enable overcurrent protection and even causes motor insulation damage.

You must configure the output reactor nearby the VFD when the cable length is equal to or greater than the values in the following table.

Refer to section D.5 Harmonic filters for selection based on different cable types and lengths. Note

that the supported cable length when a harmonic filter is configured cannot be cumulatively calculated with the supported cable length when no harmonic filter is used.

For example: GD270-5R5-4 supports 50m of unshielded cable. When a 1% output reactor is configured (supporting 150m of unshielded cable), the system long cable capacity is 150m, not 50+150=200m.

Table 4-5 Output filter selection for motor cable lengths (unit: m)

VFD power (kW)	Cable type	Maximum motor cable length (without reactor/filter)	Maximum motor cable length (with one 1% output reactor)	Maximum motor cable length (with one dv/dt filter)	Maximum motor cable length (with one sine wave filter)
1.5–5.5	Shielded motor cable	25	100	230	500
7.5–45		50	100	230	500
55–800		75	100	230	500
1.5–5.5	Non-shielded motor cable	50	150	450	1000
7.5–45		100	150	450	1000
55–800		150	150	450	1000

Note:

- ✧ When one VFD drives multiple motors at the same time, you are advised to take the sum of cable lengths of all motors as the total motor cable length.
- ✧ Since output reactors need to be configured for 220kW–800kW VFDs, choose the GD270-220-4-L3(-EU) – GD270-800-4-L3(-EU) models.
- ✧ The motor cable lengths given in the table above represent the limit capacity of the VFD. In practical applications, it is recommended to design based on 80% of the motor cable lengths in the table.

4.3.2 Main circuit terminals

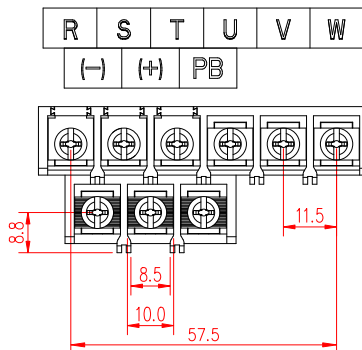

Figure 4-22 Main circuit terminals for 380V 1.5–7.5kW (unit: mm)

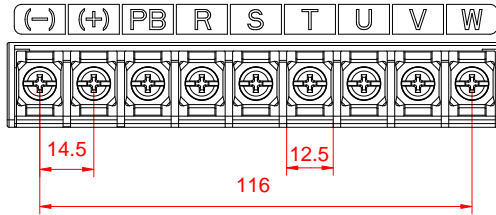

Figure 4-23 Main circuit terminals for 380V 11-15kW (unit: mm)

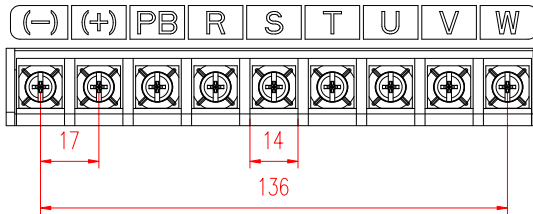

Figure 4-24 Main circuit terminals for 380V 18.5-22kW (unit: mm)

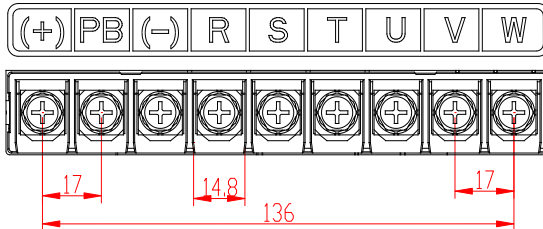

Figure 4-25 Main circuit terminals for 380V 30-37kW (unit: mm)

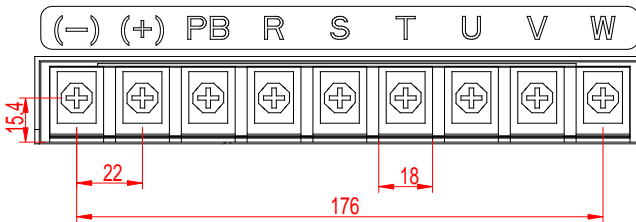

Figure 4-26 Main circuit terminals for 380V 45kW (unit: mm)

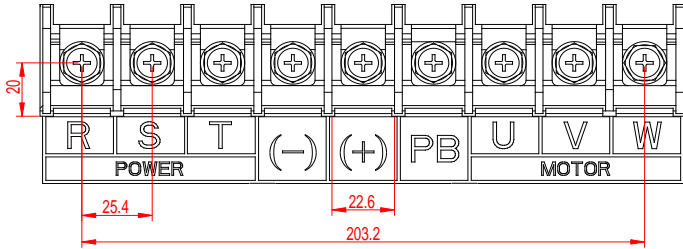

Figure 4-27 Main circuit terminals for 380V 55–90kW (unit: mm)

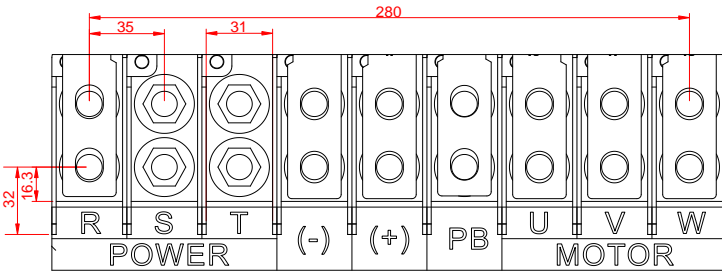

Figure 4-28 Main circuit terminals for 380V 110–132kW (unit: mm)

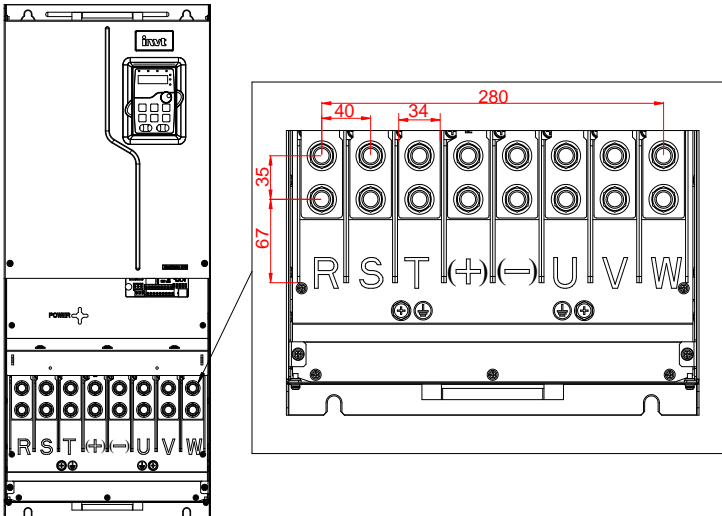

Figure 4-29 Main circuit terminals for 380V 160–200kW (unit: mm)

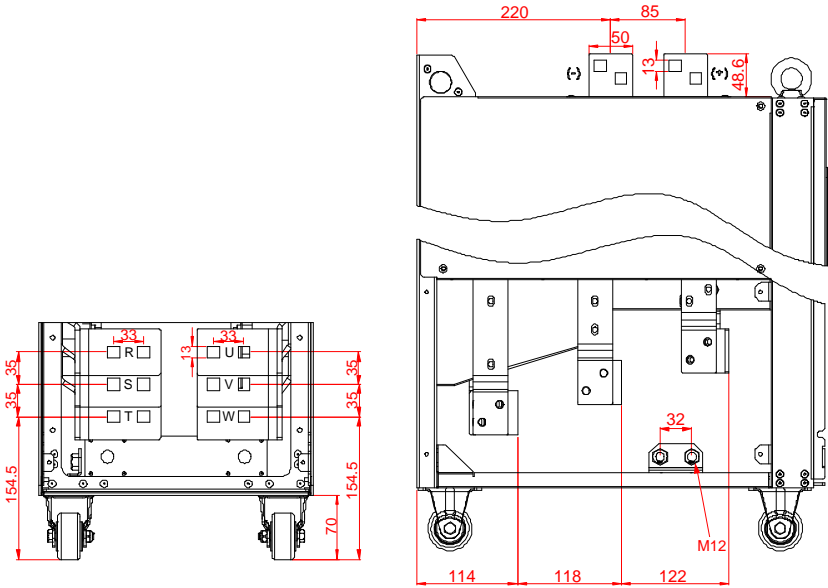

Figure 4-30 Main circuit terminal for 3PH 380V 220–250kW standard models and (-L1) models with built-in DC reactors (unit: mm)

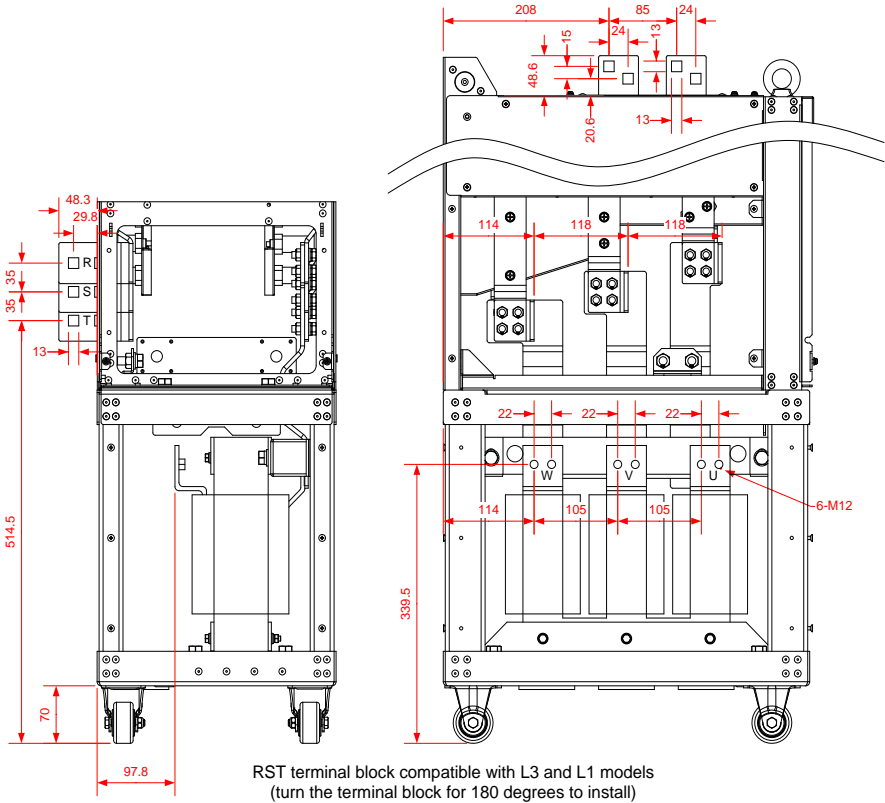

Figure 4-31 Main circuit terminal for 3PH 380V 220–250kW (-L3) models with output reactors (unit: mm)

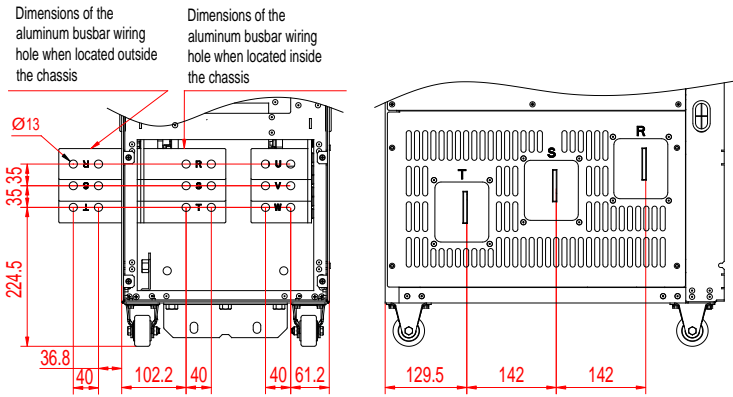

Figure 4-32 Input aluminum row mounting method for 380V 220–250kW models

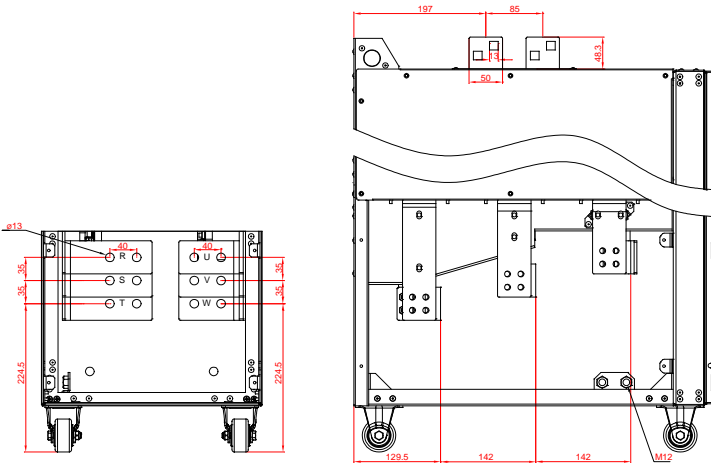

Figure 4-33 Main circuit terminal for 3PH 380V 280–355kW standard models and (-L1) models with built-in DC reactors (unit: mm)

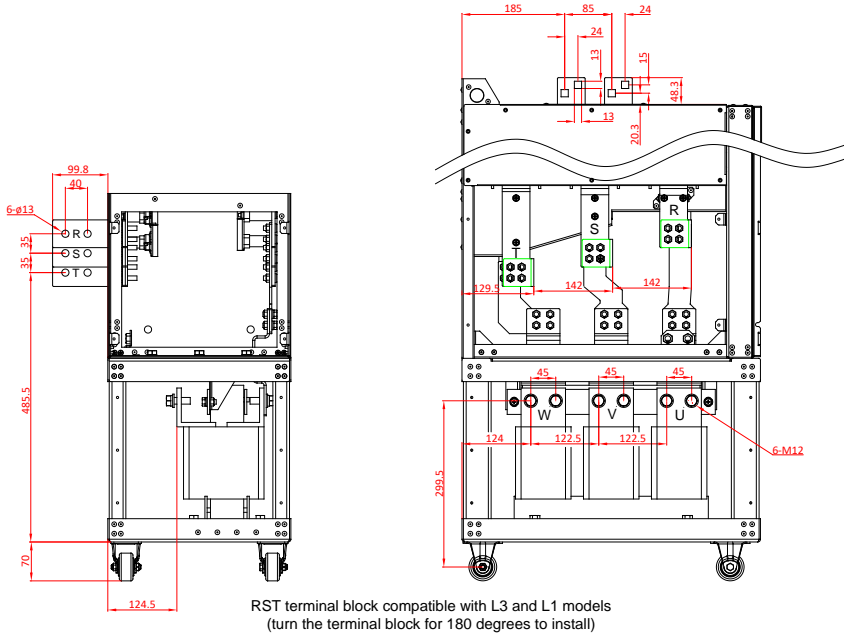

Figure 4-34 Main circuit terminal for 3PH 380V 280–355kW (-L3) models with output reactors (unit: mm)

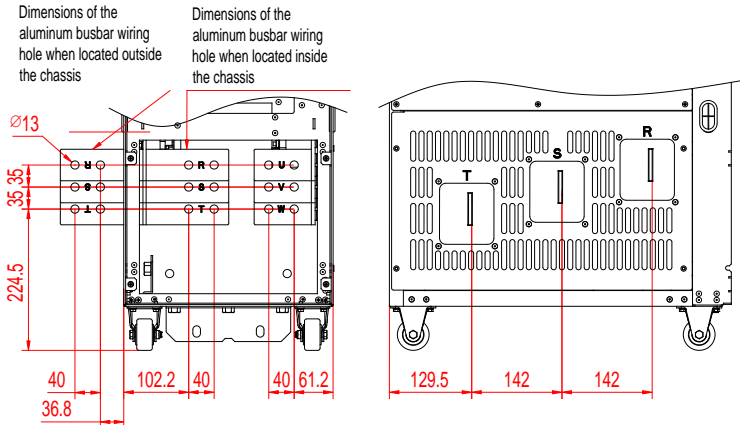

Figure 4-35 Input aluminum row mounting method for 380V 280–355kW models

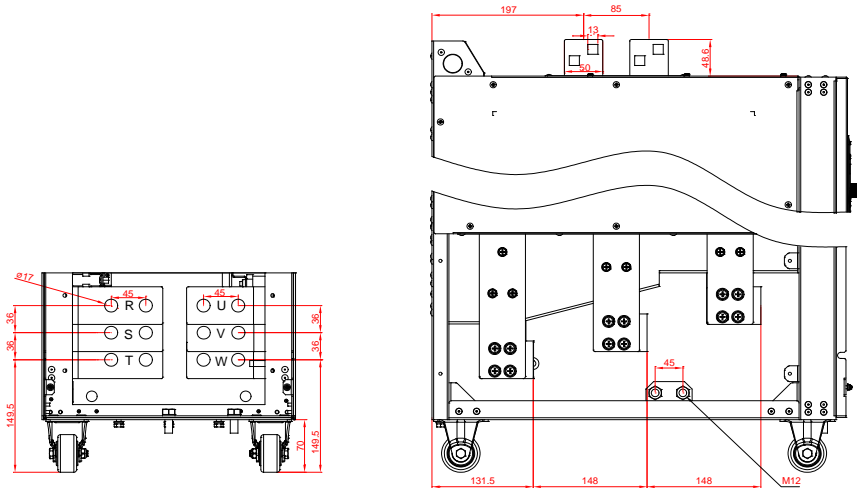
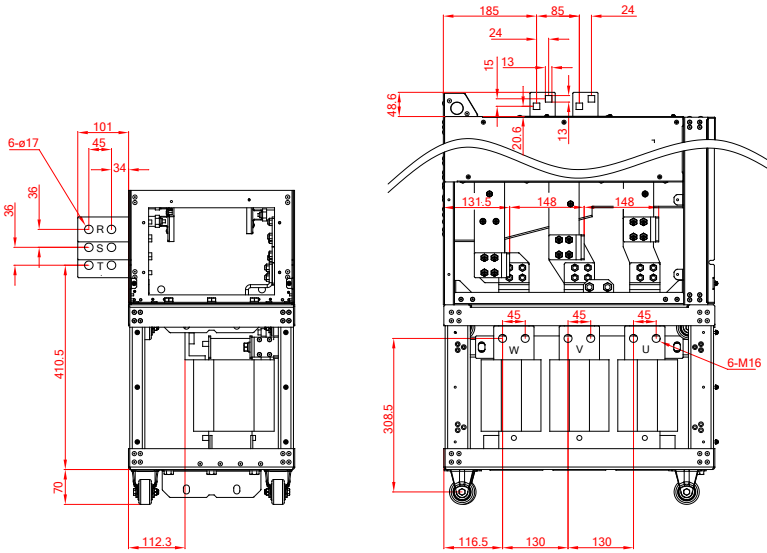

Figure 4-36 Main circuit terminal for 3PH 380V 400–500kW standard models and (-L1) models with built-in DC reactors (unit: mm)



RST terminal block compatible with L3 and L1 models
 (turn the terminal block for 180 degrees to install)

Figure 4-37 Main circuit terminal for 3PH 380V 400–500kW (-L3) models with output reactors (unit: mm)

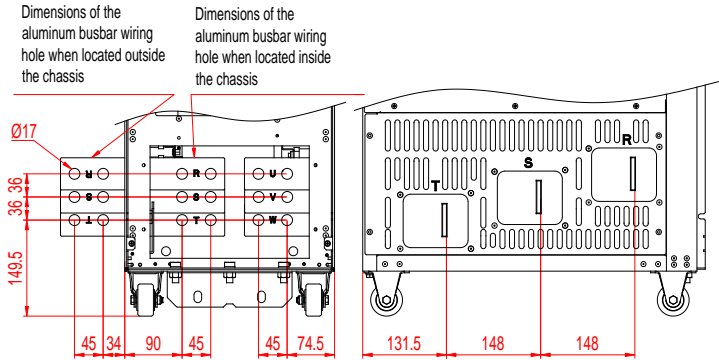

Figure 4-38 Output aluminum row mounting method for 380V 400–500kW models (unit: mm)

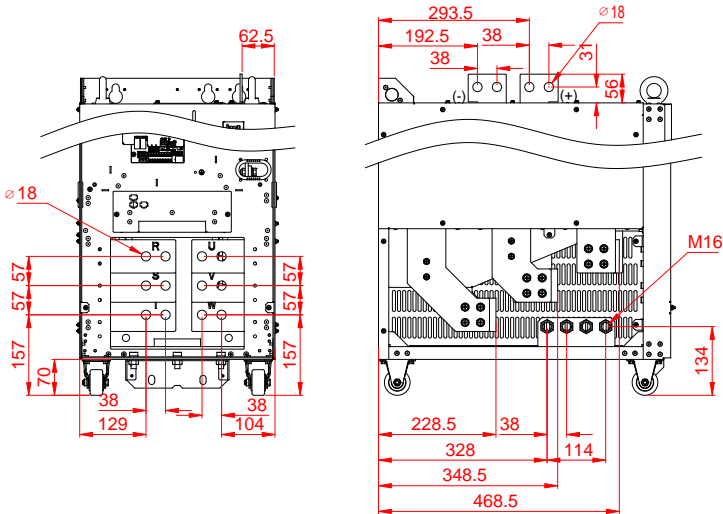

Figure 4-39 Main circuit terminal for 3PH 380V 560–630kW standard models and (-L1) models with built-in DC reactors (unit: mm)

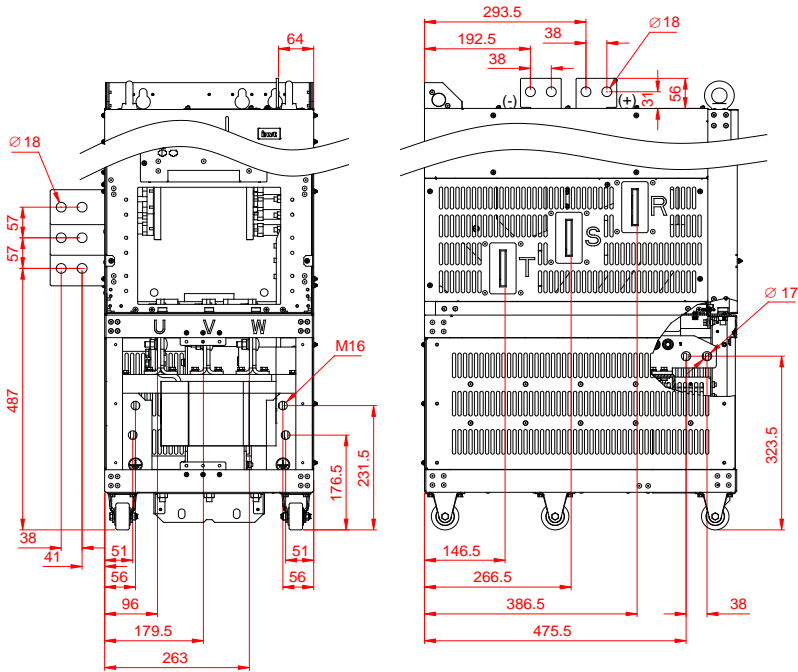

Figure 4-40 Main circuit terminal for 3PH 380V 560–630kW (-L3) models with output reactors (unit: mm)

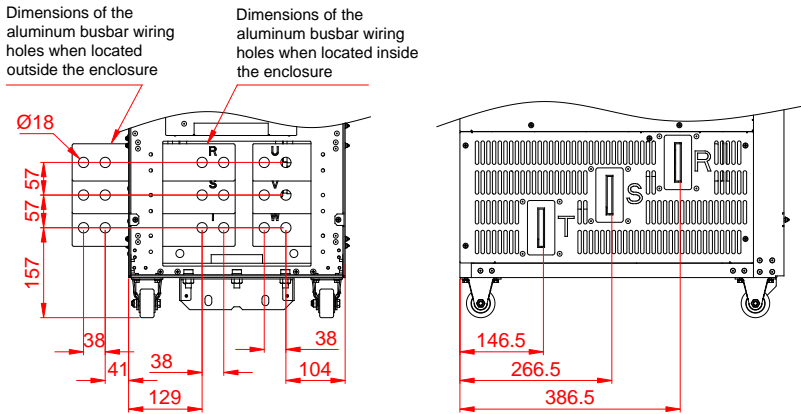

Figure 4-41 Output aluminum row mounting method for 380V 560–630kW models (unit: mm)

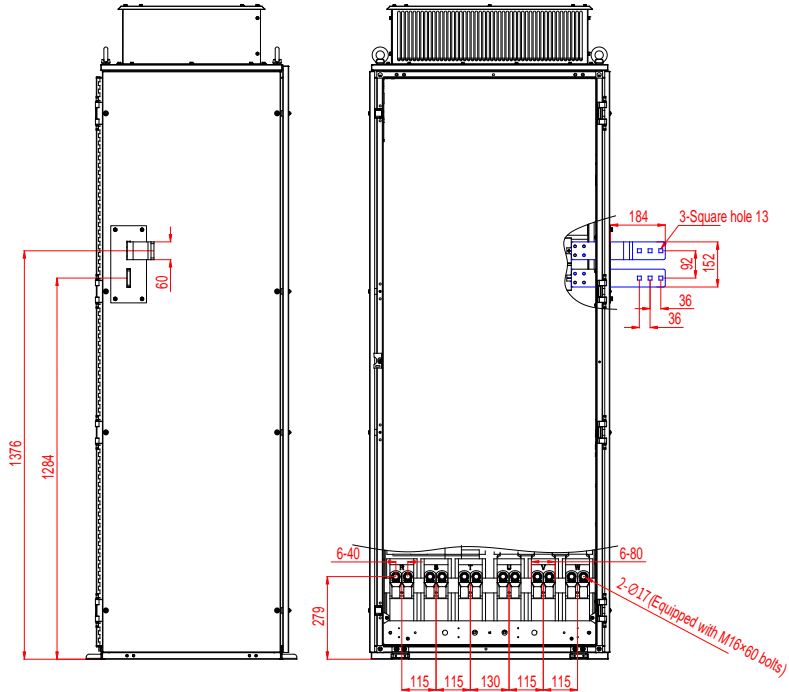

Figure 4-42 Main circuit terminal for 3PH 380V 710–800kW models (unit: mm)

Table 4-6 Terminal description

Terminal symbol	Function description
R, S, T	3PH AC input terminals, connected to the grid
U, V, W	3PH AC output terminals, connected to the motor usually
(+)	(+) and (-) can share the DC bus or connect to an external DC power supply.
(-)	
PE	Grounding terminal for safe protection; each machine must carry two PE terminals and proper grounding is required
PB	Reserved for design only. Braking function is not available.

Note:

- ◇ It is not recommended to use asymmetrical motor cables. If there is a symmetrical grounding conductor in the motor cable besides the conductive shielded layer, ground the grounding conductor on the inverter end and motor end.
- ◇ Route the motor cable, input power cable and control cable separately.

4.3.3 Wiring procedure for main circuit terminals

1. Connect the grounding line of the input power cable to the grounding terminal (PE) of the VFD, and connect the 3PH input cable to R, S and T terminals and tighten up.
2. Connect the ground wire of the motor cable to the PE terminal of the VFD, connect the motor 3PH cable to the U, V and W terminals, and tighten up.
3. Fasten all the cables outside the VFD mechanically if allowed.

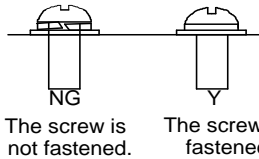

Figure 4-43 Screw installation diagram

4.3.4 Wiring of basic control circuit

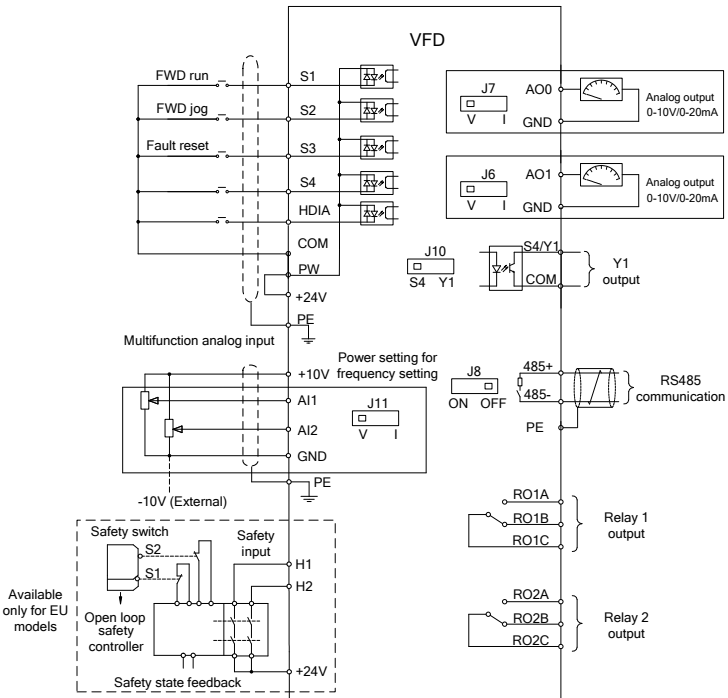

Figure 4-1 Control circuit wiring

Note: If wire-passing board outlet space is insufficient when all terminals on the control board are

wired, cut the knock-out hole on the lower cover for wire outlet. If a dangerous situation occurs when the knock-out hole is cut for a purpose but not wire outlet, we will not bear any responsibility.

Terminal name	Description	
+10V	Locally provided +10.5V power supply	
AI1	Input range: For AI1, 0(2)–10V or 0(4)–20mA	
AI2	For AI2, -10V–+10V Input impedance: 20kΩ for voltage input or 250Ω for current input Whether voltage or current is used for input is set through jumper J11. Resolution: 5mV when 10V corresponds to 50Hz Deviation: ±0.5% at 25°C, when input is above 5V/10mA	
GND	+10.5V reference ground	
AO0	Output range: 0(2)–10V or 0(4)–20mA	
AO1	Whether voltage or current is used for output of AO0 and AO1 is set through jumpers J7 and J6. Error: ±0.5% when output is 5V at 25°C	
RO1A	RO1 output; RO1A: NO; RO1B: NC; RO1C: common Contact capacity: 3A/AC250V, 1A/DC30V	
RO1B		
RO1C		
RO2A	RO2 output; RO2A: NO; RO2B: NC; RO2C: common Contact capacity: 3A/AC250V, 1A/DC30V	
RO2B		
RO2C		
COM	+24V reference ground	
Y1	Switch capacity: 50mA/30V Output frequency range: 0–1kHz Y1 and S4 share the output terminal. The selection is made through J10.	
485+	RS485 communication port, RS485 differential signal port and standard RS485 communication port must use shielded twisted pairs; the 120ohm terminal matching resistor for RS485 communication is connected through jumper J8.	
485-		
PE	Grounding terminal	
PW	External power input terminal for digital input circuits Voltage range: 12–30V	
24V	User power supply provided by the VFD, 24V(-10%–+15%). Max. output current: 200mA	
S1	Digital input 1	<ul style="list-style-type: none"> ● Internal impedance: 3.3kΩ ● 12–30V voltage input is acceptable ● Bi-direction input terminal, supporting both NPN and PNP ● Max. input frequency: 1kHz ● All are programmable digital input terminals, the functions of
S2	Digital input 2	
S3	Digital input 3	
S4	Digital input 4	

Terminal name	Description
	which can be set through function codes <ul style="list-style-type: none"> ● S4 and Y1 share the output terminal. The selection is made through J10.
HDIA	In addition to digital input functions, the terminal can also act as a high frequency pulse input channel. Max. input frequency: 50kHz Duty ratio: 30%–70%
H1	<ul style="list-style-type: none"> ● Safe torque off (STO) inputs
H2	<ul style="list-style-type: none"> ● STO redundant input, connected to the external NC contact. When the contact opens, STO acts and the VFD stops output. ● Safety input signal wires use shielded wires whose length is within 25m. ● The H1 and H2 terminals are short connected to +24V by default. Remove the jumper from the terminals before using the STO function. <p>Note:</p> <ol style="list-style-type: none"> 1. Only the -EU Models support safe-torque-off function. 2. For the 1.5-7.5kW -EU models, the extended interface SLOT1 will be occupied due to the H1/H2 terminals

4.3.5 Input/output signal connection

Set NPN /PNP mode and internal/external power via U-shaped jumper. NPN internal mode is adopted by default.

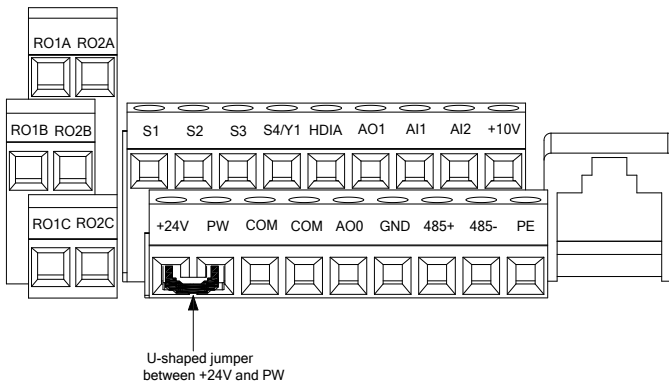

Figure 4-2 3PH 380V 1.5–7.5kW U-shaped short-circuit position

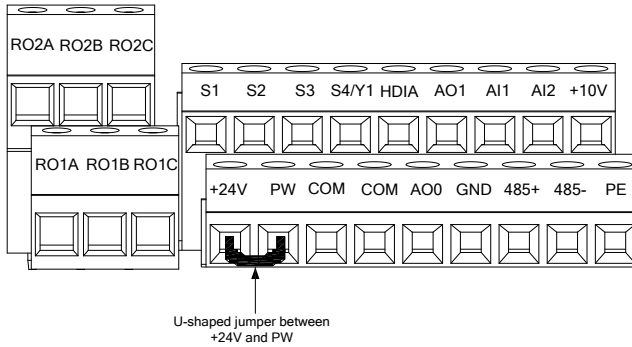

Figure 4-3 3PH 380V 11–800kW U-shaped short-circuit position

If the input signal comes from the NPN transistor, set the U-shaped jumper between +24V and PW based on the power used according to the following figure.

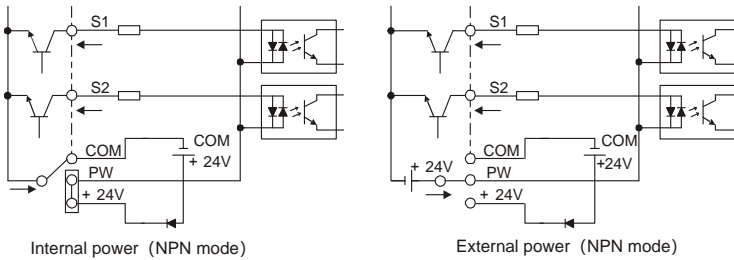

Figure 4-4 NPN mode

If the input signal comes from the PNP transistor, set the U-shaped jumper based on the power used according to the following figure.

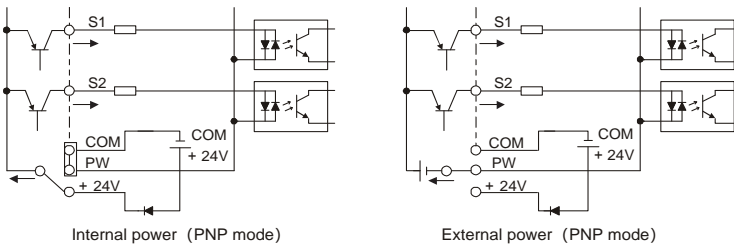

Figure 4-5 PNP mode

4.3.6 External optional keypad wiring

GD270 supports optional LED keypad (BOP-270) and LCD keypad (SOP-270). Note the following when externally connecting an optional keypad:

- ◇ The 1.5–22kW models use the film keypad design, which allows you to connect an external optional LED or LCD keypad to the electrical cabinet through the keypad interface A. With connection to an external keypad, the VFD support display and operation on both the local film keypad and external keypad.
- ◇ The 30kW and higher models are configured with independent keypads as standard parts. Before delivery, the local keypad of any of these models has been connected to the keypad interface B by default. If you want to move the keypad from the local to the electrical cabinet, to ease wiring, disconnect the default keypad wiring and connect the keypad through the keypad interface A. Keypad interfaces A and B cannot be connected at the same time. Otherwise, the keypad fails to operate or display properly.

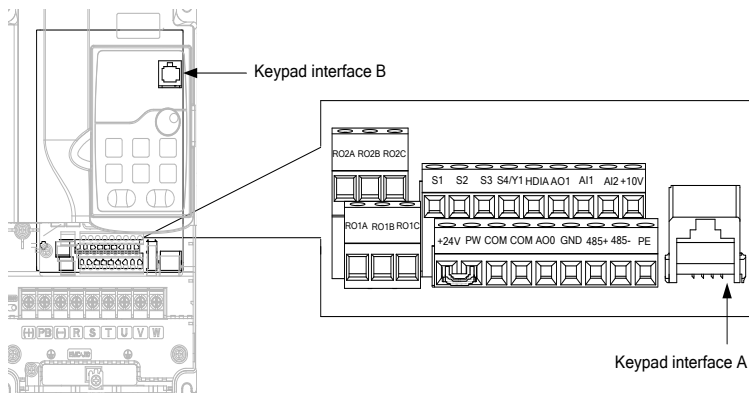

Figure 4-6 External keypad interface

4.3.7 Wiring protection

1. Protecting the VFD and input power cable in case of short circuit

The VFD and input power cable can be protected in case of short circuit, avoiding thermal overload. Carry out protective measures according to the following figure.

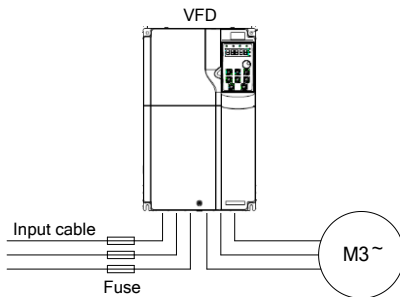

Figure 4-7 Fuse configuration

Note: Select the fuse according to the manual. In case of short circuit, the fuse protects input power cables to avoid damage to the VFD; if internal short-circuit occurs to the VFD, it can protect neighboring equipment from being damaged.

2. Protecting the motor and motor cable in case of short circuit

If the motor cable is selected based on VFD rated current, the VFD is able to protect the motor cable and motor during short circuit without other protective devices.



If the VFD is connected to multiple motors, use a separated thermal overload switch or breaker to protect the cable and motor, which may require the fuse to cut off the short circuit current.

3. Protecting the motor against thermal overload

The motor must be protected against thermal overload. Once overload is detected, current must be cut off. The VFD is equipped with the motor thermal overload protection function, which can block output and cut off the current (if necessary) to protect the motor.

4. Bypass connection

In some critical scenarios, the power/variable frequency conversion circuit needs to be configured to ensure proper operation of the system when a fault occurs to the VFD.

In some special scenarios, such as in soft startup, power-frequency running is directly performed after the startup, which requires bypass connection.



Do not connect any power source to the VFD output terminals U, V, and W. The voltage applied to the motor cable may cause permanent damage to the VFD.

If frequent switchover is needed, you can use the switch which carries mechanical interlock or a contactor to ensure motor terminals are not connected to input power cables and VFD output ends simultaneously.

5 Basic operation guidelines

5.1 What this chapter contains

This chapter instructs you how to use the VFD keypad and commission the VFD common functions.

5.2 Operation procedure

The VFD is equipped with a LED keypad as a standard configuration part. You can use the keypad to control the start and stop, read status data, and set parameters of the VFD. You can also choose a LCD keypad. The LCD keypad supports multi-language display, parameter copying function, and 10-line high-definition display. Its overall size is the same as the LED keypad.



Note:

- ✧ The 1.5–22kW VFDs are equipped with film keypads as standard configuration. If you need an external keypad and bracket, please purchase them separately.
- ✧ The 30–800kW VFDs come standard with a LED keypad that can be externally led. If you need to do so, you only need to purchase the optional bracket.



5.3 LED keypad (BOP-270) display and operation





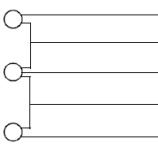

The VFD keypad can display the stopped-state parameters, running-state parameters, function parameter editing status, and fault alarm status.

You can operate the VFD by using the keypad. For details about function code descriptions, see the function code list.

Table 5-1 LED keypad (BOP-270) component description

No.	Name	Description	
1	Status indicator	RUN/TUNE	VFD operation status indicator Off: The VFD is stopped.

No.	Name	Description																																																																							
			Blinking: The VFD is in parameter autotuning On: The VFD is running.																																																																						
		FWD/REV	Forward or reverse running indicator Off: The VFD is running forward. On: The VFD is running.																																																																						
		LOCAL/REMOT	Indicates whether the VFD is controlled through the keypad, terminals, or communication. Off: The VFD is controlled through the keypad. Blinking: The VFD is controlled through terminals. On: The VFD is controlled remotely.																																																																						
		TRIP	Fault indicator Off: The VFD is in normal state. Blinking: The VFD is in pre-alarm state. On: The VFD is in fault state.																																																																						
2	Unit indicator	Unit displayed currently																																																																							
			Hz	Frequency unit																																																																					
			RPM	Rotation speed unit																																																																					
			A	Current unit																																																																					
			%	Percentage																																																																					
V	Voltage unit																																																																								
3	Digital display zone	Five-digit LED displays various monitoring data and alarm codes such as the frequency setting and output frequency.																																																																							
		<table border="1" style="width: 100%; text-align: center;"> <thead> <tr> <th>Display</th> <th>Means</th> <th>Display</th> <th>Means</th> <th>Display</th> <th>Means</th> </tr> </thead> <tbody> <tr> <td>0</td> <td>0</td> <td>1</td> <td>1</td> <td>2</td> <td>2</td> </tr> <tr> <td>3</td> <td>3</td> <td>4</td> <td>4</td> <td>5</td> <td>5</td> </tr> <tr> <td>6</td> <td>6</td> <td>7</td> <td>7</td> <td>8</td> <td>8</td> </tr> <tr> <td>9</td> <td>9</td> <td>A</td> <td>A</td> <td>b</td> <td>b</td> </tr> <tr> <td>C</td> <td>C</td> <td>d</td> <td>d</td> <td>E</td> <td>E</td> </tr> <tr> <td>F</td> <td>F</td> <td>H</td> <td>H</td> <td>I</td> <td>I</td> </tr> <tr> <td>L</td> <td>L</td> <td>N</td> <td>N</td> <td>n</td> <td>n</td> </tr> <tr> <td>O</td> <td>O</td> <td>P</td> <td>P</td> <td>r</td> <td>r</td> </tr> <tr> <td>S</td> <td>S</td> <td>t</td> <td>t</td> <td>U</td> <td>U</td> </tr> <tr> <td>v</td> <td>v</td> <td>.</td> <td>.</td> <td>-</td> <td>-</td> </tr> </tbody> </table>						Display	Means	Display	Means	Display	Means	0	0	1	1	2	2	3	3	4	4	5	5	6	6	7	7	8	8	9	9	A	A	b	b	C	C	d	d	E	E	F	F	H	H	I	I	L	L	N	N	n	n	O	O	P	P	r	r	S	S	t	t	U	U	v	v	.	.	-	-
		Display	Means	Display	Means	Display	Means																																																																		
		0	0	1	1	2	2																																																																		
		3	3	4	4	5	5																																																																		
		6	6	7	7	8	8																																																																		
		9	9	A	A	b	b																																																																		
		C	C	d	d	E	E																																																																		
		F	F	H	H	I	I																																																																		
		L	L	N	N	n	n																																																																		
O	O	P	P	r	r																																																																				
S	S	t	t	U	U																																																																				
v	v	.	.	-	-																																																																				
4	Digital potentiometer	Used for frequency regulation. For details, see the description of P08.42.																																																																							
5	Keys		Programming key	Press it to enter or exit level-1 menus or delete a parameter.																																																																					

No.	Name	Description	
		Confirmation key	Press it to enter menus in cascading mode or confirm the setting of a parameter.
		UP key	Press it to increase data or move upward.
		Down key	Press it to decrease data or move downward.
		Right-shifting key	Press it to select display parameters rightward in the interface for the product in stopped or running state or to select digits to change during parameter setting.
		Run key	Press it to run the product when using the keypad for control.
		Stop/Reset key	Press it to stop the VFD that is running. The function of this key is restricted by P07.04. In fault alarm state, this key can be used for reset in any control modes.
		Multifunction shortcut key	The function of this key is determined by the ones place of P07.02.

5.3.1 Displaying stopped-state parameters

When the VFD is in stopped state, the keypad displays stopped-state parameters, as shown in Figure 5-4.

In the stopped state, various kinds of parameters can be displayed. You can determine which parameters are displayed in stopped state by setting function code P07.07. For details, see the description of P07.07.

In stopped state, there are 15 parameters that can be selected for display, including the set frequency, bus voltage, PID reference value, PID feedback value, input terminal status, output terminal status, torque setting, PLC and the present step of multi-step speed, AI1 value, AI2 value, AI3 value, high-speed pulse HDI frequency, pulse counting value, length value, and upper limit frequency (Hz on). You can press **➤ /SHIFT** to shift selected parameters from left to right or press **QUICK/JOG** (when ones place of P07.02=2) to shift selected parameters from right to left.

5.3.2 Displaying running-state parameters

After receiving a valid running command, the VFD enters the running state, and the keypad displays running-state parameters, with the **RUN/TUNE** indicator on. The on/off state of the **FWD/REV** indicator is determined by the actual running direction. It is shown as Figure 5-4.

In running state, there are 25 parameters that can be selected for display, including the running frequency, set frequency, bus voltage, output voltage, output current, running speed, output power, output torque, PID reference value, PID feedback value, input terminal status, output terminal status,

torque setting, length value, PLC and the current step of multi-step speed, AI1, AI2, AI3, high-speed pulse HDI frequency, motor overload percentage, VFD overload percentage, ramp reference value, linear speed, AC input current, and upper limit frequency (Hz on). You can determine which parameters are displayed in stopped state by setting function codes P07.05 and P07.06. You can press **▶/SHIFT** to shift selected parameters from left to right or press **QUICK/JOG** (when ones place of P07.02=2) to shift selected parameters from right to left.

5.3.3 Displaying fault alarms

After detecting a fault signal, the VFD enters the fault alarm state immediately, the fault code blinks on the keypad, and the TRIP indicator is on. You can perform fault reset by using the **STOP/RST** key, control terminals, or communication commands.

If the fault persists, the fault code is continuously displayed.

5.3.4 Editing function codes

You can press the **PRG/ESC** key to enter the editing mode in stopped, running, or fault alarm state (if a user password is used, see the description of P07.00). The editing mode contains two levels of menus in the following sequence: Function code group or function code number → Function code setting. You can press the **DATA/ENT** key to enter the function parameter display interface. In the function parameter display interface, you can press the **DATA/ENT** key to save parameter settings or press the **PRG/ESC** key to exit the parameter display interface.

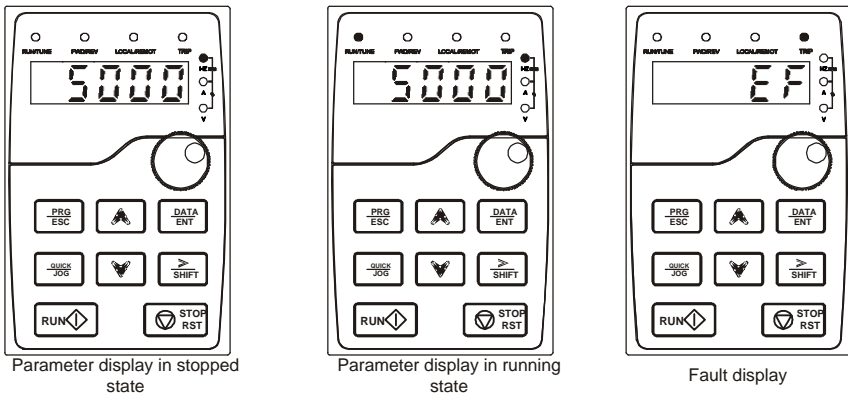

Figure 5-4 State display

5.3.5 Modifying function codes

The VFD provides three levels of menus, including:

- ✧ Function code group number (level-1 menu)
- ✧ Function code number (level-2 menu)
- ✧ Function code setting (level-3 menu)

Note: When performing operations on the level-3 menu, you can press the **PRG/ESC** or **DATA/ENT** key to return to the level-2 menu. If you press the **DATA/ENT** key, the set value of the parameter is saved to the control board first, and then the level-2 menu is returned, displaying the next function code. If you press the **PRG/ESC** key, the level-2 menu is returned directly, without saving the set value of the parameter, and the current function code is displayed.

If you enter the level-3 menu but the parameter does not have a digit blinking, the parameter cannot be modified due to either of the following reasons:

- ✧ It is read only. Read-only parameters include actual detection parameters and running record parameters.
- ✧ It cannot be modified in running state and can be modified only in stopped state.

Example: Change the value of P00.01 from 0 to 1.

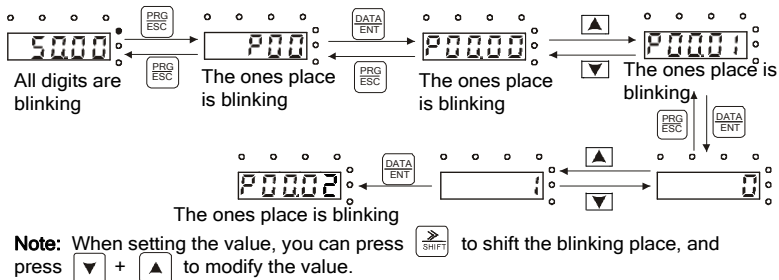

Figure 5-5 Modifying a parameter

5.3.6 Setting a password for the VFD

The VFD provides the user password protection function. When P07.00 is set to a non-zero value, the value is the user password. To disable the password protection function, you only need to set P07.00 to 0.

After you exit the function code editing interface, the password protection function is enabled within 1 minute. If password protection is enabled, "0.0.0.0.0" is displayed when you press the **PRG/ESC** key again to enter the function code editing interface. You need to enter the correct user password to enter the interface.

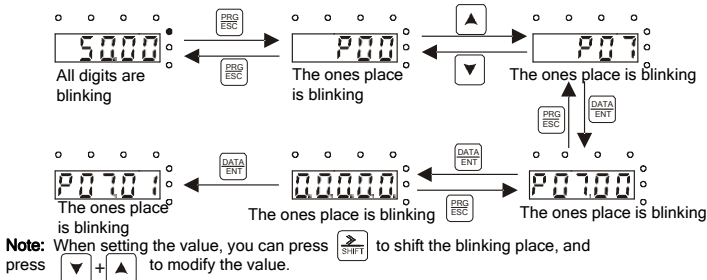

Figure 5-6 Setting a password

5.3.7 Viewing VFD status

The VFD provides group P17 for status viewing. You can enter group P17 for viewing.

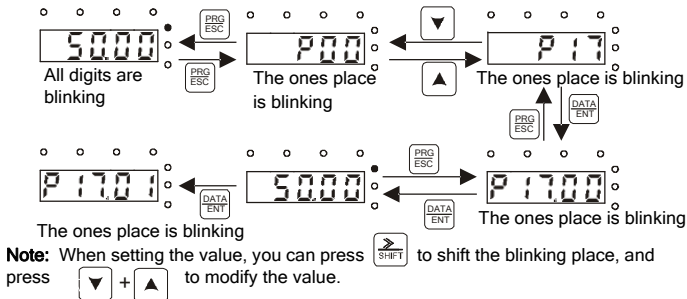











Figure 5-7 Viewing a parameter

5.4 LCD keypad (SOP-270) display and operation

Table 5-2 LCD keypad (SOP-270) component description

No.	Name	Description	
1	Status indicator		Run indicator Off: The VFD is stopped. Blinking: The VFD is in parameter autotuning. On: The VFD is running.
			Fault indicator Off: The VFD is in normal state. Blinking: The VFD is in pre-alarm state. On: The VFD is in fault state.
			Short-cut key indicator, which displays different state under different functions, see definition of key for details.
2	Keys		Function key The function of function key varies with the

No.	Name	Description	
			<p>menu.</p> <p>The function of function key is displayed in the footer.</p>
		Short-cut key	<p>Re-definable. It is defined as JOG function by default, namely jogging. The function of short-cut key can be set by the ones place of P07.02, as shown in the following:</p> <p>0: No function 1: Jogging (linkage indicator (3); logic : NO) 2: Reserved 3: FWD/REV switch-over (linkage indicator (3); logic: NC) 4: Clear the UP/DOWN setting (linkage indicator (3) logic: NC) 5: Coast to stop (linkage indicator (3); logic : NC) 6: Switch command channels in sequence (linkage indicator (3); logic: NC) 7: Reserved</p> <p>Note: After restoring to default values, the default function of short-cut key is 1.</p>
		Confirmation key	<p>The function of confirmation key varies with menus, such as confirming parameter setup, confirming parameter selection, and entering the next menu.</p>
		Run key	<p>Under keypad operation mode, the running key is used for running operation or autotuning operation.</p>
		Stop/Reset key	<p>Press it to stop the VFD that is running or autotuning. The function of this key is restricted by P07.04. In fault alarm state, this key can be used for reset in any control modes.</p>
		<p>Direction key</p> <p>UP: </p> <p>DOWN: </p> <p>LEFT: </p> <p>RIGHT: </p>	<p>UP: The function of UP key varies with interfaces, such as shifting up the displayed item, shifting up the selected item, and changing digits;</p> <p>DOWN: The function of DOWN key varies with interfaces, such as shifting down the displayed item, shifting down the selected item, changing digits;</p> <p>Left: The Left key function varies with interfaces,</p>

No.	Name	Description		
				such as switch over the monitoring interface, such as shifting the cursor leftward, exiting current menu and returning to previous menu. RIGHT: The function of RIGHT key varies with interfaces, such as switch over the monitoring interface, shifting the cursor rightward, enter the next menu etc.
3	Display area	LCD screen	Display screen	240x160 dot-matrix LCD; display three monitoring parameters or six sub-menu items simultaneously.
4	Other	RJ45 interface	RJ45 interface	RJ45 interface is used to connect to the VFD.
		Battery cover	Clock battery cover	Remove this cover when replacing or installing clock battery, and close the cover after battery is installed.
		USB terminal	Mini USB terminal	Mini USB terminal is used to connect to the USB flash drive through an adapter.

The LCD has different display areas, which displays different contents under different interfaces. The following figure is the main interface of stop state.

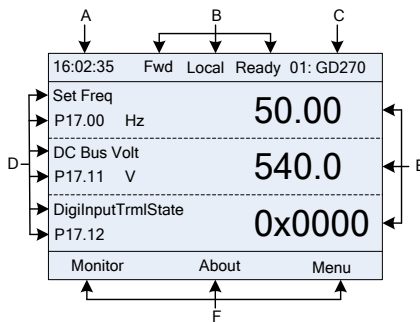



Figure 5-8 LCD main interface

Area	Name	Display
Header A	Real-time display area	Display the real-time; clock battery is not included; the time needs to be reset when powering on the VFD
Header B	VFD running state display area	Display the running state of the VFD: Display motor rotating direction: "Forward" – Run forward during operation; Reverse – Run reversely during operation; "Forbid" – Reverse running is forbidden;

Area	Name	Display
		Display VFD running command channel: "Local" – Keypad; "Terminal" – Terminal; "Remote" - Communication; Display current running state of the VFD : "Ready" – The VFD is in stop state (no fault); "Run" – The VFD is in running state; "Jog" – The VFD is in jogging state; "Pre-alarm" – the VFD is under pre-alarm state during running; "Fault" – VFD fault occurred.
Header C	VFD station No. and model display area	Display VFD station No.: 01–99, applied in multi-drive applications (reserved function); VFD model display: "GD270" – current VFD is GD270 series VFD.
Display D	The parameter name and function code monitored by the VFD	Display the parameter name and corresponding function code monitored by the VFD; three monitoring parameters can be displayed simultaneously. The monitoring parameter list can be edited.
Display E	Parameter value monitored by the VFD	Display the parameter value monitoring by the VFD, the monitoring value will be refreshed in real time
Footer F	Corresponding menu of function key	The corresponding menu of the function key varies with interfaces, and the content in this area also varies.

The VFD keypad can display the stopped-state parameters, running-state parameters, function parameter editing status, and fault alarm status.

5.4.1 Displaying stopped-state parameters

When the VFD is in stopped state, the keypad displays stopped-state parameters, and this interface is the main interface during power-on by default. Under stop state, parameters in various states can be displayed. Press  or  to shift the displayed parameter up or down.

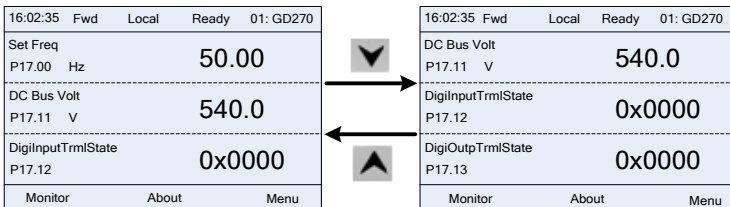



Figure 5-9 Stopped-state parameter display 1

Press  or  to switch between different display styles, including list display style and progress bar display style.

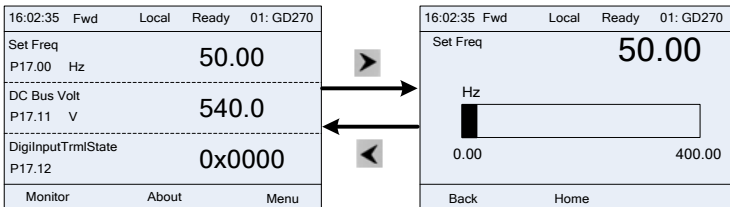

Figure 5-10 Stopped-state parameter display 2

The stopped-state parameter display list is user defined, and each state variable function code can be added to the list as needed. The state variable which has been added to the list can also be deleted or shifted.

5.4.2 Displaying running-state parameters

After receiving valid running command, the VFD will enter running state, and the keypad displays running state parameter with **RUN** indicator on the keypad turning on. Under running state, multiple kinds of state parameters can be displayed. Press **▲** or **▼** to shift up or down.

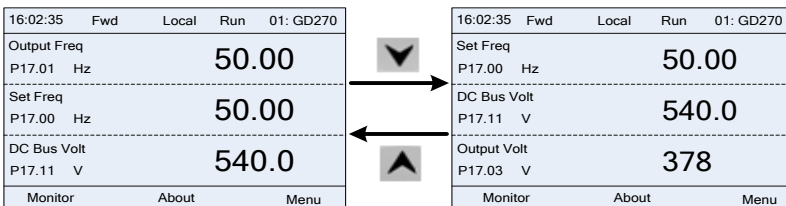

Figure 5-11 Running-state parameter display 1

Press **◀** or **▶** to switch between different display styles, including list display style and progress bar display style.

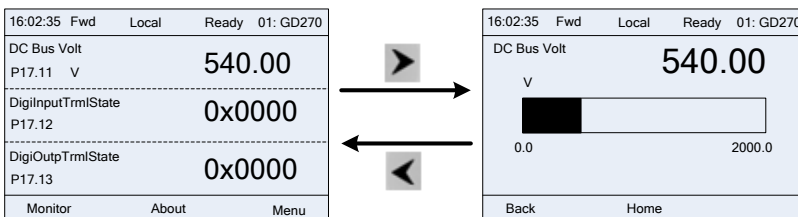

Figure 5-12 Running-state parameter display 2

Under running state, multiple kinds of state parameters can be displayed. The running display parameter list is user defined, and each state variable function code can be added to the running display parameter list as needed. The state variable which has been added to the running display parameter list can also be deleted or shifted.

5.4.3 Displaying fault alarms

The VFD enters the fault alarm display state once fault signal is detected, and the keypad displays

fault code and fault information with TRIP indicator on the keypad turning on. You can perform fault reset by using the **STOP/RST** key, control terminals, or communication commands.

If the fault persists, the fault code is continuously displayed.

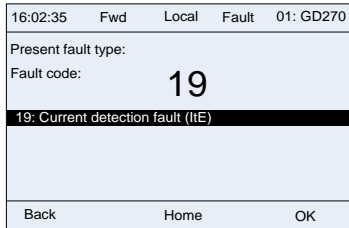

Figure 5-13 Fault alarm display

Various operations can be performed on the VFD, including entering/exiting menu, parameter selection, list modification and parameter addition.

5.4.4 Enter/exit menu

Regarding the monitoring menu, the operation relation between entering and exiting is shown as follows.

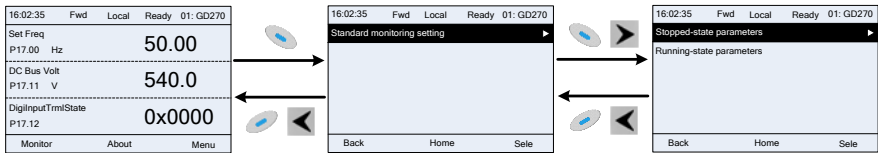

Figure 5-14 Entering/exiting different menus 1

The following figure shows how to enter or exit different menus step by step.

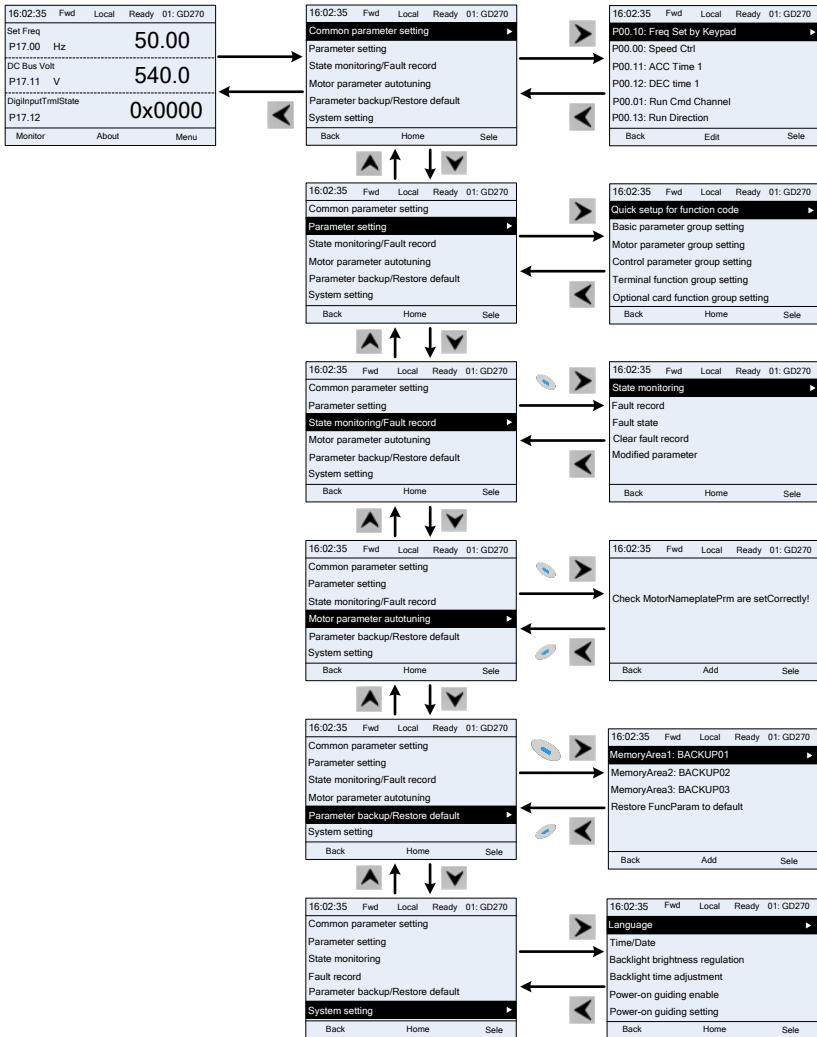

Figure 5-15 Entering/exiting different menus 2

The keypad menu setup is shown as follows:

Level 1	Level 2	Level 3	Level 4
Common parameter setup	/	/	P00.10: Setting frequency through keypad
			P00.00: Speed control mode
			Pxx.xx: xx
Parameter setting	Quick setup for function code	/	Pxx.xx
	Basic parameter group setup	P00: Basic functions	P00.xx
		P07: Human-machine interface	P07.xx
		P08: Enhanced functions	P08.xx
		P11: Protection parameters	P11.xx
		P14: Serial communication function group	P14.xx
		P99: Reserved	P99.xx
	Motor parameter group setup	P02: Motor 1 parameters	P02.xx
		P12: Motor 2 parameters	P12.xx
		P20: Reserved	P20.xx
		P24: Reserved	P24.xx
	Control parameter group setup	P01: Start and stop control	P01.xx
		P03: Vector control of motor 1	P03.xx
		P04: V/F control	P04.xx
		P09: PID control	P09.xx
		P10: Simple PLC and multi-step speed control	P10.xx
		P13: SM control parameters	P13.xx
		P21: Reserved	P21.xx
		P22: Reserved	P22.xx
	Terminal function group setup	P05: Input terminal functions	P05.xx
		P06: Output terminal functions	P06.xx
		P98: Reserved	P98.xx
	Optional card function group setup	P15: Communication expansion card 1 functions	P15.xx
		P16: Communication expansion card 2 functions	P16.xx
		P25: Expansion I/O card input functions	P25.xx
		P26: Expansion I/O card output functions	P26.xx
		P27: Reserved	P27.xx
		P28: Master/slave control	P28.xx
	Factory-defined control function group setup	P90: PID control 1	P90.xx
		P91: PID control 2	P91.xx
		92: Real-time clock and timer (available at use of LCD keypad)	P92.xx

Level 1	Level 2	Level 3	Level 4	
State monitoring/fault record	State monitoring	P93: Fire control	P93.xx	
		P07: Human-machine interface	P07.xx	
		P17: Status viewing functions	P17.xx	
		P18: Reserved	P18.xx	
	Fault record	/		P07.27: Type of present fault
				P07.28: Type of the last fault
				P07.29: Type of the 2nd-last fault
				P07.30: Type of the 3rd-last fault
				P07.31: Type of the 4th-last fault
	Fault state	/		P07.32: Type of the 5th-last fault
				P07.33: Running frequency at present fault
				P07.34: Ramp frequency at present fault
	Clear fault records	/		P07.xx: xx state of the last but xx fault
				Are you sure to clear fault history?
	Modified parameter	/		Pxx.xx has modified parameter 1
Pxx.xx has modified parameter 2				
Pxx.xx has modified parameter xx				
Motor parameter autotuning	/	/	Dynamic autotuning 1	
			Complete parameter static autotuning	
			Partial parameter static autotuning 1	
			Dynamic autotuning 2	
			Partial parameter static autotuning 2	
Parameter backup/restore default value	/	Operate the storage area 1: BACKUP01	Upload parameters from the local address to the keypad	
			Download all param from keypad	
			Download non motor param from keypad	
			Download motor param from keypad	
		Memory area 2: BACKUP02	/	
		Memory area 3: BACKUP03	/	
		Restore function parameter to default	Are you sure to restore function	

Level 1	Level 2	Level 3	Level 4
		value	parameters to default value?
System setting	/	/	Language selection
			Time/date
			Backlight brightness regulation
			Backlight time adjustment
			Power-on guiding enable
			Power-on guiding settings
			Keypad burning selection
			Enable fault time
			Control board burning selection

5.4.5 Editing list

The parameters in the parameter list in stopped state can be added as needed (through the menu of user defined home parameters), and the list can also be edited such as "Move up", "Move down", "Delete from the list", and "Restore default". The edit function is shown in the following.

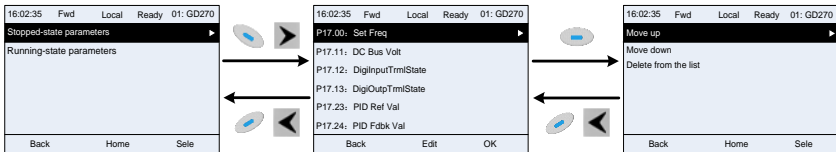

Figure 5-16 Editing list 1

Press key to enter edit interface, select the operation needed, and press the key, key or key to confirm the edit operation and return to the previous menu (parameter list), the returned list is the list edited. If the key or key is pressed in edit interface without selecting an edit operation, it will return to the previous menu (parameter list remain unchanged).

Note: For the parameter objects in the list header, move-up operation will be invalid, and the same principle can be applied to the parameter objects in the list footer; after deleting a certain parameter, the parameter objects under it will be moved up automatically.

The items in the parameter list in running state can be added as needed (through the menu of user defined home parameters), and the list can also be edited such as "Place top", "Move up", "Move down", "Delete from the list", and "Restore default parameters". The edit function is shown in the interface below.

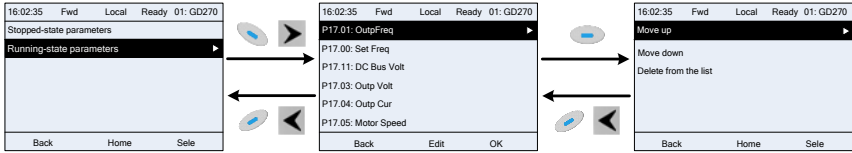

Figure 5-17 Editing list 2

The parameters of user defined parameter setting can be added, deleted or adjusted as needed, such as "Place top", "Move up", "Move down", "Delete from the list", and "Restore default parameters"; the adding function can be set in a certain function code in a function group. The edit function is shown in the figure below.



Figure 5-18 Editing list 3

5.4.6 Adding parameters to the parameter list displayed in stopped/running state

You can choose **Menu > State monitoring**, choose a submenu, and enter a specific function group and then a specific function code to add the parameter to the list of parameters displayed in stopped state or parameters displayed in running state.

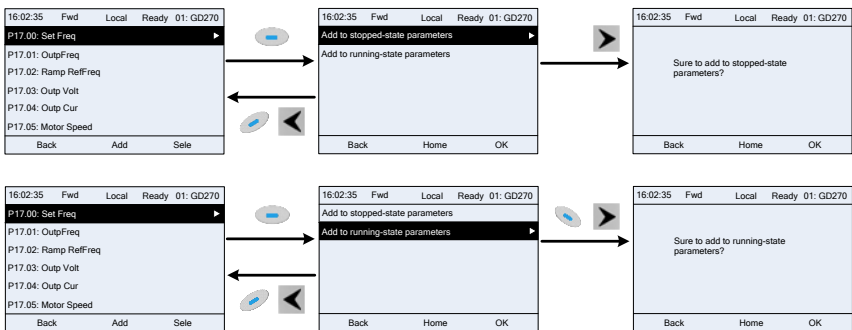



Figure 5-19 Adding parameters 1

After selecting a specific function code, press key to enter parameter addition interface, and press key, key or key to confirm the addition operation. If this parameter is not included in the list of parameters displayed in stopped state or list of parameters displayed in running state, the parameter added will be at the end of the list; if the parameter is already in the list of parameters displayed in stopped state or list of parameters displayed in running state, the addition

operation will be invalid. If  key or  key is pressed without selecting addition operation in "Addition" interface, it will return to monitoring parameter list menu.

Part of the monitoring parameters in P07 HMI group can be added to the "parameter displayed in stop state" list or "parameter displayed in running state" list; all the parameters in P17, P18 and P19 group can be added to the "parameter displayed in stop state" list or "parameter displayed in running state" list.

Up to 16 monitoring parameters can be added to the list of parameters displayed in stopped state; and up to 32 monitoring parameters can be added to the list of parameters displayed in running state.

5.4.7 Add parameter to common parameter setup list

You can choose **Menu > Parameter groups**, choose a submenu, and enter a specific function group and then a specific function code to add the parameter to the user defined parameter list.

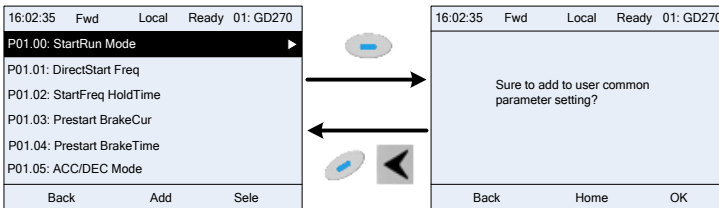















Figure 5-20 Adding parameters 2

Press  key to enter addition interface, and press  key,  key or  key to confirm the addition operation. If this parameter is not included in the original user defined parameter list, the newly-added parameter will be at the end of the list; if this parameter is already in the user defined parameter list, the addition operation will be invalid. If  key or  key is pressed without selecting addition operation, it will return to parameter setup list menu.

All the function code groups under the submenu can be added to user defined parameter list. Up to 64 function codes can be added to the user defined parameter list.

5.4.8 Parameter selection edit interface

After accessing a specific function code under the **User defined parameters** menu, you can press the  key,  key or  key to enter the parameter edit interface. After entering the edit interface, the present value is highlighted. Press the  key and  key to edit the parameter value, and the corresponding parameter item of current value will be highlighted automatically. After the edit operation is completed, press  or  key to save the selected parameter and return to the previous menu; or press  key to maintain the value and return to the previous menu.

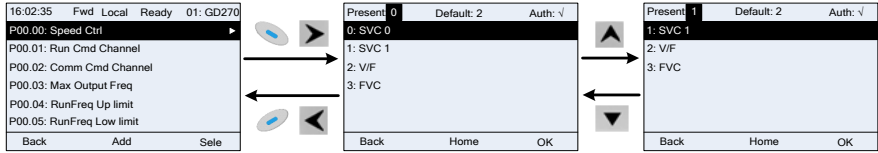

Figure 5-21 Parameter selection edit interface

In parameter selection edit interface, the "Auth" field in the upper right corner indicates whether this parameter is editable or not.

"√" indicates the set value of this parameter can be modified under current state.

"x" indicates the set value of this parameter cannot be modified under the present.

"Present" indicates the actually selected value.

"Default" indicates the default value of this parameter.

5.4.9 Parameter setup edit interface

You can choose **Menu > Parameter groups**, enter a specific function group and then a specific function code, and then press key, key or key to edit the parameter setting interface. After entering edit interface, set the parameter from low bit to high bit, and the bit under setting will be highlighted. Press key or key to increase or decrease the parameter value (this operation is valid until the parameter value exceeds the max. value or min. value); press or to shift the editing bit. After parameters are set, press or key to save the set parameters and return to the previous menu; press to maintain the original parameter value and return to the previous menu.

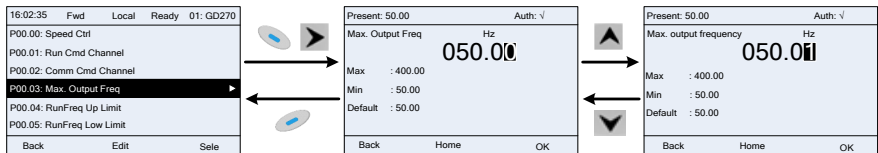

Figure 5-22 Parameter setup edit interface

In parameter selection edit interface, the "Auth" field in the upper right corner indicates whether this parameter is editable or not.

"√" indicates the set value of this parameter can be modified under current state.

"x" indicates the set value of this parameter cannot be modified under the present.

"Present" indicates the value saved last time.

"Default" indicates the default value of this parameter.

5.4.10 State monitoring interface

You can choose **Menu > State monitoring > State monitoring parameter**, enter a specific function group and then a specific function code, and press key, key or key to enter the

state monitoring interface. After entering the state monitoring interface, the actual parameter value will be displayed in real time, this value is the actually detected value which cannot be modified.

In the state monitoring interface, you can press  key or  key to return to the previous menu.

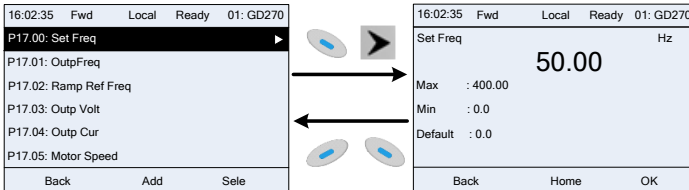







Figure 5-23 State monitoring interface

5.4.11 Motor parameter autotuning

You can choose **Menu > Motor parameter autotune** and press ,  key or  key to enter motor parameter autotuning interface. However, before entering the motor parameter autotuning interface, you must set the motor nameplate parameters correctly. After entering the interface, select a motor autotuning type to carry out motor parameter autotuning. In motor parameter autotuning interface, you can press  key or  key to return to the previous menu.

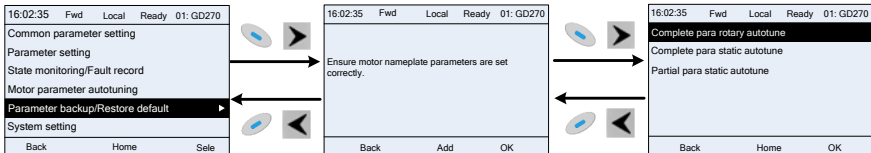

Figure 5-24 Parameter autotuning operation

After selecting a motor autotuning type, enter motor parameter autotuning interface, and press **RUN** key to start motor parameter autotuning. After autotuning is done, a message will pop up indicating autotuning is succeeded, and then it will return to the main interface of stop. During autotuning, you can press **STOP/RST** key to terminate autotuning; if any fault occur during autotuning, the keypad will display a fault interface.

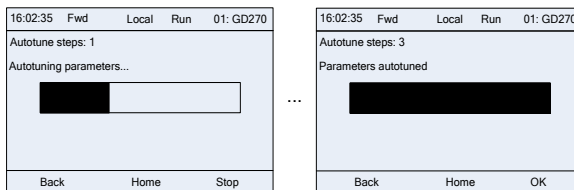

Figure 5-25 Parameter autotuning finished

5.4.12 Parameter backup

You can choose **Menu > Copy parameter/Restore default**, and press ,  key or  key

key to enter the function parameter backup interface and function parameter restoration interface to upload/download VFD parameters, or restore VFD parameters to default values. The keypad has three different storage areas for parameter backup, and each storage area can save the parameters of one VFD, which means the keypad can save parameters of three VFDs in total.

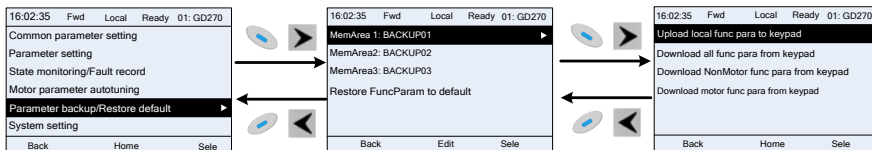

Figure 5-26 Parameter backup

5.4.13 System setting

You can choose **Menu > System settings**, and press key, key or key to enter system setting interface to set the keypad language, time/date, backlight brightness, backlight time and restore parameters.

Note: Clock battery is not included, and the keypad time/date needs to be reset after power off. If time-keeping after power off is needed, you should purchase the clock batteries separately.

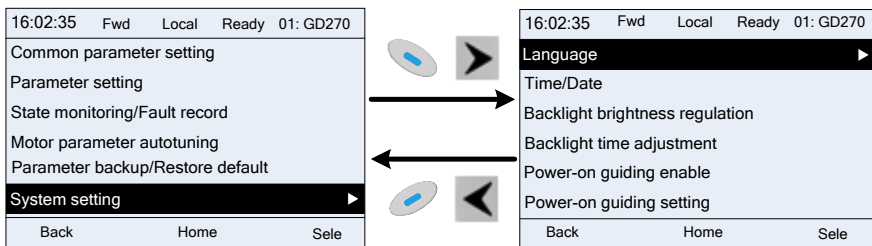

Figure 5-27 System setting

5.4.14 Power-on guiding settings

The keypad supports the power-on guiding function, mainly for the first power-on situation, guiding you to enter the setting menu, and gradually implementing basic functions such as basic parameter setting, direction judgment, mode setting and autotuning. The power-on guiding enable menu guides you to enable power-on to boot each time. Power-on guiding setup menu guides you to set step by step according to the functions. The power-on guide is shown as follows:

Level 1		Level 2		Level 3		Level 4	
Language	0: Simplified Chinese	Power-on guiding enable	0: Always	Whether to enter the power-on guiding settings?	0: Yes	Whether to test the motor rotation direction?	Yes
	1: English		1: Only once		1: No		No
			P00.06	0: Keypad		Press the JOG	Yes

Level 1		Level 2		Level 3		Level 4	
				Setting channel of A frequency command	1: AI1	button first. Is it currently forward. Is it consistent with the expectations?	No
					2: AI2	P02.00 Type of motor 1	0: AM
					3: AI3		1: SM
					4: High-speed pulse HDIA	P02.01 Rated power of AM 1	
					5: Simple PLC program	P02.02 Rated frequency of AM 1	
					6: Multi-step speed running	P02.03 Rated speed of AM 1	
					7: PID control	P02.04 Rated voltage of AM 1	
					8: Modbus/Modbus TCP communication	P02.05 Rated current of AM 1	
					9: PROFIBUS/CANopen /BACnet MSTP communication	P02.15 Rated power of SM 1	
					10: Ethernet communication	P02.16 Rated frequency of SM 1	
					11: High-speed pulse HDIB	P02.17 Number of pole pairs of SM 1	
					12: Pulse train AB	P02.18 Rated voltage of SM 1	
					13: PROFINET/ Ethernet IP communication	P02.19 Rated current of SM 1	
					14: Programmable card	Whether to conduct autotuning?	Yes
					15–17: Reserved		
				18: Keypad (applicable to 1.5–22kW models)	No		

Level 1		Level 2		Level 3		Level 4		
				P00.01 Running command channel	0: Keypad	Motor parameter autotuning interface		
					1: Terminal			
					2: Communication			
				P00.02 Communication mode of running commands	0: Modbus/Modbus TCP communication			
					1: PROFIBUS/CANopen /BACnet MSTP communication			
					2: Ethernet communication			
					3: PROFINET/EtherNet IP communication			
					4: Programmable card			
					5: Wireless communication card			
				P08.37 Reserved				
				P00.00 Speed control mode	0: SVC mode 0			
					1: SVC mode 1			
					2: Space voltage vector control mode			
				P01.08 Stop mode	0: Decelerate to stop			
					1: Coast to stop			
				P00.11 ACC time 1				
				P00.12 DEC time 1				

5.5 Basic operation description

5.5.1 What this section describes

This section introduces the function modules inside the VFD.

	<ul style="list-style-type: none"> ◇ Ensure that all terminals have been securely connected. ◇ Ensure that the motor power matches the VFD power.
---	---

5.5.2 Common commissioning procedure

The common commissioning procedure is as follows (taking motor 1 as an example).

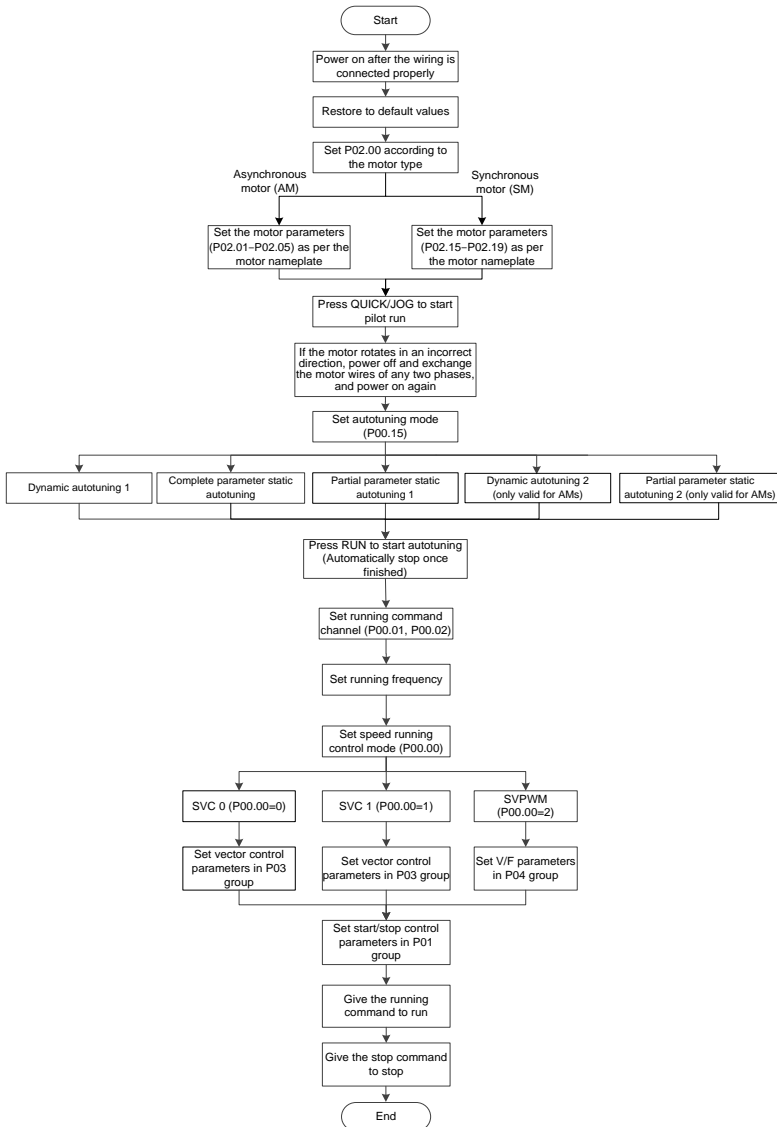

Note: If a fault occurred, remove the fault cause according to "Fault tracking".

The running command channel can be set through terminal commands in addition to P00.01 and P00.02.

Channel of running commands P00.01	Multifunction terminal function 36 Switch the running command channel to keypad	Multifunction terminal function 37 Switch the running command channel to terminal	Multifunction terminal function 38 Switch the running command channel to communication
Keypad	/	Terminal	Communication
Terminal	Keypad	/	Communication
Communication	Keypad	Terminal	/

Note: "/" indicates this multifunction terminal is invalid under present reference channel.

Related function parameters

Function code	Name	Description	Default
P00.00	Speed control mode	0: SVC mode 0 1: SVC mode 1 2: Space voltage vector control mode Note: Before using a vector control mode (0 or 1), enable the VFD to perform motor parameter autotuning first.	2
P00.01	Channel of running commands	0: Keypad 1: Terminal 2: Communication	0
P00.02	Communication mode of running commands	0: Modbus/Modbus TCP communication 1: PROFIBUS/CANopen /BACnet MSTP communication 2: Ethernet communication 3: PROFINET/EtherNet IP communication 4: Programmable card 5: Wireless communication card	0
P00.15	Motor parameter autotuning	0: No operation 1: Dynamic autotuning 1; comprehensive motor parameter autotuning. It is recommended to use dynamic autotuning when high control accuracy is required. 2: Complete parameter static autotuning; used in scenarios where the motor cannot be disconnected from load. 3: Partial parameter static autotuning 1;	0

Function code	Name	Description	Default
		when the present motor is motor 1, only P02.06, P02.07, and P02.08 are autotuned; when the present motor is motor 2, only P12.06, P12.07, and P12.08 are autotuned. 4: Dynamic autotuning 2; similar to dynamic autotuning 1, but only valid for AMs 5: Partial parameter static autotuning 2; only valid for AMs	
P00.18	Function parameter restoration	0: No operation 1: Restore to default values (excluding motor parameters) 2: Clear fault records 3: Lock keypad parameters 4: Reserved 5: Restore to default values (factory test mode) 6: Restore to default values (including motor parameters) Note: After the selected operation is performed, the function code is automatically restored to 0. Restoring the default values may delete the user password. Exercise caution when using this function.	0
P02.00	Type of motor 1	0: Asynchronous motor (AM) 1: Synchronous motor (SM)	0
P02.01	Rated power of AM 1	0.1–3000.0kW	Model depended
P02.02	Rated frequency of AM 1	0.01Hz–P00.03 (Max. output frequency)	50.00Hz
P02.03	Rated speed of AM 1	1–60000rpm	Model depended
P02.04	Rated voltage of AM 1	0–1200V	Model depended
P02.05	Rated current of AM 1	0.8–6000.0A	Model depended
P02.15	Rated power of SM 1	0.1–3000.0kW	Model depended
P02.16	Rated frequency of SM 1	0.01Hz–P00.03 (Max. output frequency)	50.00Hz

Function code	Name	Description	Default
P02.17	Number of pole pairs of SM 1	1–50	2
P02.18	Rated voltage of SM 1	0–1200V	Model depended
P02.19	Rated current of SM 1	0.8–6000.0A	Model depended
P05.01–P05.06	Function selection of multifunction digital input terminals (S1–S4, and HDIA)	36: Switch the running command channel to keypad 37: Switch the running command channel to terminal 38: Switch the running command channel to communication	
P07.01	Parameter copy	Used to set the parameter copy mode. 0: No operation 1: Upload parameters to the keypad 2: Download all parameters (including motor parameters) 3: Download non-motor parameters 4: Download motor parameters Note: After any operation among 1–4 is completed, the parameter restores to 0. The upload and download functions are not applicable to group P29.	0
P07.02	Function of QUICK/JOG	Range: 0x00–0x28 Ones place: Function of QUICK/JOG 0: No function 1: Jog 2: Reserved 3: Switch between forward and reverse rotating 4: Clear the UP/DOWN setting 5: Coast to stop 6: Switch command channels in sequence 7: Quick commissioning mode 8: Switch command channels in sequence + frequency switchover Note: When switching to keypad control, the frequency is determined by the setting of P00.10; in other cases, it is determined by P00.06. Tens place: Reserved	0x01

5.5.3 Vector control

AMs feature high order, nonlinearity, strong coupling and multi-variables, which increase difficulty to control AMs during actual application. The vector control technology solves this situation as follows: measures and controls the stator current vector of the AM, and then decomposes the stator current vector into exciting current (current component that generates internal magnet field) and torque current (current component that generates torque) based on field orientation principle, and therefore controls the amplitude values and phase positions of the two components (namely, controls the stator current vector of the AM) to realize decoupled control on exciting current and torque current, thus achieving high-performance speed regulation of the AM.

Integrated with the sensor-less vector control algorithm, the VFD can drive both AMs and permanent-magnet SMs. As the core algorithm of vector control is based on accurate motor parameter models, the accuracy of motor parameters affects vector control performance. It is recommended to enter accurate motor parameters and autotune motor parameters before executing vector control.

As the vector control algorithm is complicated, exercise caution before modifying vector control function parameters.

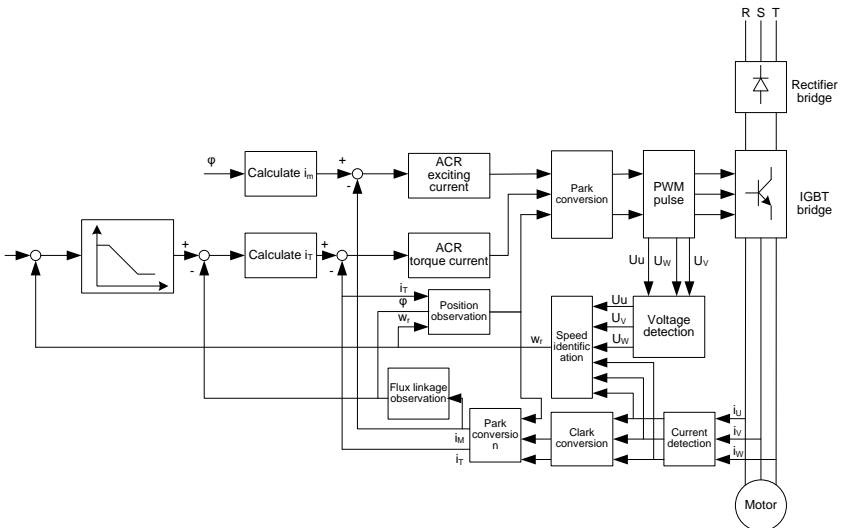

Function code	Name	Description	Default
P00.00	Speed control mode	0: SVC mode 0 1: SVC mode 1 2: Space voltage vector control mode Note: Before using a vector control mode (0 or 1), enable the VFD to perform motor	2

Function code	Name	Description	Default
		parameter autotuning first.	
P00.15	Motor parameter autotuning	<p>0: No operation</p> <p>1: Dynamic autotuning 1 Comprehensive motor parameter autotuning. It is recommended to use rotating autotuning when high control accuracy is required.</p> <p>2: Complete parameter static autotuning Used in scenarios where the motor cannot be disconnected from load.</p> <p>3: Partial parameter static autotuning 1 When the present motor is motor 1, only P02.06, P02.07, and P02.08 are autotuned; when the present motor is motor 2, only P12.06, P12.07, and P12.08 are autotuned.</p> <p>4: Dynamic autotuning 2; similar to dynamic autotuning 1, but only valid for AMs</p> <p>5: Partial parameter static autotuning 2 (valid only for AMs)</p>	0
P02.00	Type of motor 1	<p>0: Asynchronous motor (AM)</p> <p>1: Synchronous motor (SM)</p>	0
P03.00	Speed-loop proportional gain 1	0–200.0	20.0
P03.01	Speed-loop integral time 1	0.000–10.000s	0.200s
P03.02	Low-point frequency for switching	0.00Hz–P03.05	5.00Hz
P03.03	Speed-loop proportional gain 2	0–200.0	20.0
P03.04	Speed-loop integral time 2	0.000–10.000s	0.200s
P03.05	High-point frequency for switching	P03.02–P00.03 (Max. output frequency)	10.00 Hz
P03.06	Speed-loop output filter	0–8 (0–2 ⁸ /10ms)	0
P03.07	Electromotive slip compensation coefficient of vector control	50%–200%	100%
P03.08	Braking slip compensation coefficient of vector control	50%–200%	100%
P03.09	Current-loop proportional	0–65535	1000

Function code	Name	Description	Default
	coefficient P		
P03.10	Current-loop integral coefficient I	0–65535	1000
P03.11	Torque setting method selection	1: Keypad (P03.12) 2: AI1 3: AI2 4: AI3 5: Pulse frequency HDIA 6: Multi-step torque 7: Modbus/Modbus TCP communication 8: PROFIBUS/CANopen/BACnet MSTP communication 9: Ethernet communication 10: Pulse frequency HDIB 11: PROFINET/EtherNet IP communication 12: Programmable card 13–17: Reserved 18: Keypad analog (valid for 1.5–22kW models) Note: 100% corresponds to the motor rated current.	1
P03.12	Torque set through keypad	-300.0%–300.0% (of the motor rated current)	50.0%
P03.13	Torque reference filter time	0.000–10.000s	0.010s
P03.14	Setting source of forward rotation upper-limit frequency in torque control	0: Keypad (P03.16) 1: AI1 (100% corresponds to the max. frequency) 2: AI2 (same as the above) 3: AI3 (same as the above) 4: Pulse frequency HDIA 5: Multi-step setting (same as the above) 6: Modbus/Modbus TCP communication (same as the above) 7: PROFIBUS/CANopen/BACnet MSTP communication (same as the above) 8: Ethernet communication (same as the above) 9: Pulse frequency HDIB	0

Function code	Name	Description	Default
		10: PROFINET/EtherNet IP communication (same as the above) 11: Programmable card (same as the above) 12–17: Reserved 18: Keypad analog (valid for 1.5–22kW models)	
P03.15	Setting source of reverse rotation upper-limit frequency in torque control	0: Keypad (P03.17) 1–18: Same as those for P03.14	0
P03.16	Forward rotation frequency upper limit set through keypad in torque control	Setting range: 0.00Hz–P00.03 (Max. output frequency)	50.00 Hz
P03.17	Reverse rotation upper-limit frequency set through keypad in torque control		50.00 Hz
P03.18	Setting source of electromotive torque upper limit	0: Keypad (P03.20) 1: AI1 (100% corresponds to triple the motor rated current) 2: AI2 (same as the above) 3: AI3 (same as the above) 4: Pulse frequency HDIA 5: Modbus/Modbus TCP communication 6: PROFIBUS/CANopen/BACnet MSTP communication 7: Ethernet communication 8: Pulse frequency HDIB 9: PROFINET/EtherNet IP communication 10: Programable card 11–17: Reserved 18: Keypad analog (valid for 1.5–22kW models) Note: For setting sources 0–18, 100% corresponds to three times the rated motor current.	0
P03.19	Setting source of braking torque upper limit	0: Keypad (P03.21) 1–18: Same as those for P03.18	0

Function code	Name	Description	Default
P03.20	Electromotive torque upper limit set through keypad	0.0–300.0% (of the motor rated current)	180.0%
P03.21	Braking torque upper limit set through keypad		180.0%
P03.22	Weakening coefficient in constant power zone	0.1–2.0	0.3
P03.23	Lowest weakening point in constant power zone	10%–100%	20%
P03.24	Max. voltage limit	0.0–120.0%	100.0%
P03.25	Pre-exciting time	0.000–10.000s	0.300s
P03.32	Enabling torque control	0: Disable 1: Enable	0
P03.33	Flux-weakening integral gain	0–8000	1200
P03.35	Control optimization setting	Range: 0x0000–0x1111 Ones place: Torque command selection 0: Torque reference 1: Torque current reference Tens place: Reserved Hundreds place: indicates whether to enable speed-loop integral separation 0: Disable 1: Enable Thousands place: Reserved	0x0000
P03.36	Speed-loop differential gain	0.00–10.00s	0.00s
P03.37	Proportional coefficient of high-frequency current loop	In the vector control mode (P00.00=3), when the frequency is lower than the current-loop high-frequency switching threshold (P03.39), the current-loop PI parameters are P03.09 and P03.10; and when the frequency is higher than the current-loop high-frequency switching threshold, the current-loop PI parameters are P03.37 and P03.38. Setting range of P03.37: 0–65535 Setting range of P03.38: 0–65535 Setting range of P03.39: 0.0–100.0% (of the max. frequency)	1000
P03.38	High-frequency current-loop integral coefficient		1000
P03.39	Current-loop high-frequency switching threshold		100.0%
P17.32	Flux linkage	0.0–200.0%	0.0%

5.5.4 Space voltage vector control mode

The VFD also provides the space voltage control function. The space voltage control mode can be used in cases where mediocre control precision is enough and in cases where a VFD needs to drive multiple motors.

The VFD provides multiple V/F curve modes to meet different requirements. You can select V/F curves or set V/F curves as required.

Suggestions:

1. For the load featuring constant moment, such as conveyor belt which runs in straight line, as the whole running process requires constant moment, it is recommended to adopt the straight line V/F curve.
2. For the load featuring decreasing moment, such as fan and water pumps, as there is a power (square or cube) relation between its actual torque and speed, it is recommended to adopt the V/F curve corresponding to the power of 1.3, 1.7 or 2.0.

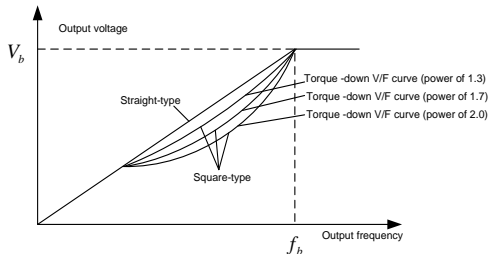

The VFD also provides multi-point V/F curves. You can change the V/F curves output by the VFD by setting the voltage and frequency of the three points in the middle. A whole curve consists of five points starting from (0Hz, 0V) and ending at (motor fundamental frequency, motor rated voltage). During setting, follow the rule: $0 \leq f1 \leq f2 \leq f3 \leq$ Motor fundamental frequency, and $0 \leq V1 \leq V2 \leq V3 \leq$ Motor rated voltage.

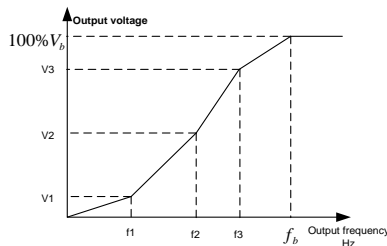

The VFD provides dedicated function codes for the space voltage control mode. You can improve the space voltage control performance by means of setting.

1. Torque boost

The torque boost function can effectively compensate for the low-speed torque performance in space voltage control. Automatic torque boost has been set by default, which enables the VFD to adjust the

torque boost value based on actual load conditions.

Note:

- ✧ Torque boost takes effect only at the torque boost cut-off frequency.
- ✧ If torque boost is too large, the motor may encounter low-frequency vibration or overcurrent. If such a situation occurs, reduce the torque boost value.

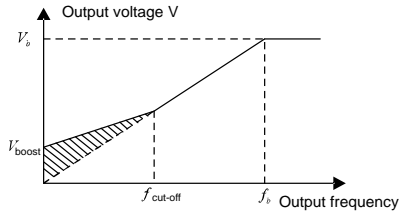

2. V/F slip compensation gain

Space voltage vector control belongs to an open-loop mode. Sudden motor load changes cause motor speed fluctuation. In cases where strict speed requirements must be met, you can set the slip compensation gain to compensate for the speed change caused by load fluctuation through VFD internal output adjustment.

The setting range of slip compensation gain is 0–200%, in which 100% corresponds to the rated slip frequency.

Note: Rated slip frequency = (Rated synchronous rotation speed of motor - Rated rotation speed of motor) x (Number of motor pole pairs)/60

3. Oscillation control

Motor oscillation often occurs in space voltage vector control in large-power driving applications. To solve this problem, the VFD provides two oscillation factor function codes. You can set the function codes based on the oscillation occurrence frequency.

Note: A greater value indicates better control effect. However, if the value is too large, the VFD output current may be too large.

4. AM IF control

Generally, the IF control mode is valid for AMs. It can be used for SMs only when the frequency is extremely low. Therefore, the IF control mode described in this manual is only involved with AMs. IF control is implemented by performing closed-loop control on the total output current of the VFD. The output voltage adapts to the current reference, and open-loop control is separately performed over the frequency of the voltage and current.

Customized V/F curve (V/F separation) function:

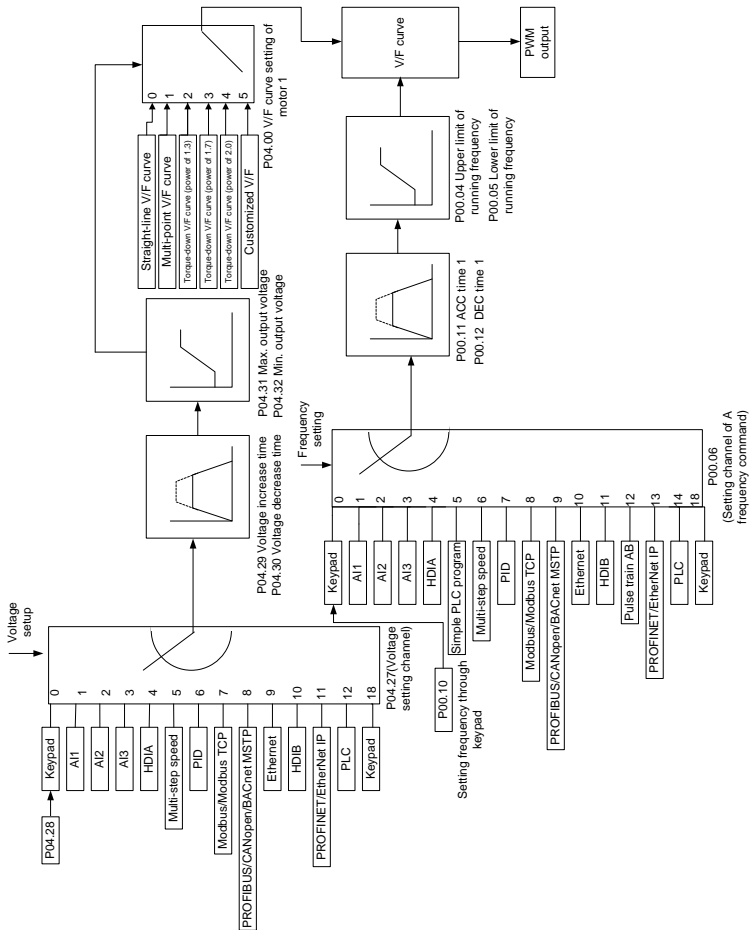

When selecting the customized V/F curve function, you can specify the setting channels and acceleration/deceleration time of voltage and frequency respectively, which form a real-time V/F curve in combination manner.

Note: This type of V/F curve separation can be applied in various variable-frequency power sources. However, exercise caution when setting parameters as improper settings may cause equipment damage.

Related function parameters:

Function code	Name	Description	Default
P00.00	Speed control mode	0: SVC mode 0 1: SVC mode 1 2: Space voltage vector control mode Note: Before using a vector control mode (0 or 1), enable the VFD to perform motor parameter autotuning first.	2
P00.03	Max. output frequency	P00.04–400.00Hz	50.00Hz
P00.04	Upper limit of running frequency	P00.05–P00.03	50.00Hz
P00.05	Lower limit of running frequency	0.00Hz–P00.04	0.00Hz
P00.11	ACC time 1	0.0–3600.0s	Model depended
P00.12	DEC time 1	0.0–3600.0s	Model depended
P02.00	Type of motor 1	0: Asynchronous motor (AM) 1: Synchronous motor (SM)	0
P02.02	Rated frequency of AM 1	0.01Hz–P00.03 (Max. output frequency)	50.00Hz
P02.04	Rated voltage of AM 1	0–1200V	Model depended
P04.00	V/F curve setting of motor 1	0: Straight-line V/F curve 1: Multi-point V/F curve 2: Torque-down V/F curve (power of 1.3) 3: Torque-down V/F curve (power of 1.7) 4: Torque-down V/F curve (power of 2.0) 5: Customized V/F curve (V/F separation)	0
P04.01	Torque boost of motor 1	0.0% (Automatic); 0.1%–10.0% (of the rated voltage of motor 1)	0.0%
P04.02	Torque boost cut-off of motor 1	0.0%–50.0% (of the rated frequency of motor 1)	20.0%
P04.03	V/F frequency point 1 of motor 1	0.00Hz–P04.05	0.00Hz
P04.04	V/F voltage point 1 of motor 1	0.0%–110.0% (of the rated voltage of motor 1)	0.0%

Function code	Name	Description	Default
P04.05	V/F frequency point 2 of motor 1	P04.03–P04.07	0.00Hz
P04.06	V/F voltage point 2 of motor 1	0.0%–110.0% (of the rated voltage of motor 1)	0.0%
P04.07	V/F frequency point 3 of motor 1	P04.05–P02.02 (Hz, P02.00=0) or P04.05–P02.16 (Hz, P02.00=1)	0.00Hz
P04.08	V/F voltage point 3 of motor 1	0.0%–110.0% (of the rated voltage of motor 1)	0.0%
P04.09	V/F slip compensation gain of motor 1	0.0–200.0%	100.0%
P04.10	Low-frequency oscillation control factor of motor 1	0–100	10
P04.11	High-frequency oscillation control factor of motor 1	0–100	10
P04.12	Oscillation control threshold of motor 1	0.00Hz–P00.03 (Max. output frequency)	30.00Hz
P04.13	V/F curve setting of motor 2	0: Straight-line V/F curve 1: Multi-point V/F curve 2: Torque-down V/F curve (power of 1.3) 3: Torque-down V/F curve (power of 1.7) 4: Torque-down V/F curve (power of 2.0) 5: Customized V/F curve (V/F separation)	0
P04.14	Torque boost of motor 2	0.0% (Automatic); 0.1%–10.0% (of the rated voltage of motor 2)	0.0%
P04.15	Torque boost cut-off of motor 2	0.0%–50.0% (of the rated frequency of motor 2)	20.0%
P04.16	V/F frequency point 1 of motor 2	0.00Hz–P04.18	0.00Hz
P04.17	V/F voltage point 1 of motor 2	0.0%–110.0% (of the rated voltage of motor 2)	0.0%
P04.18	V/F frequency point 2 of motor 2	P04.16–P04.20	0.00Hz
P04.19	V/F voltage point 2 of motor 2	0.0%–110.0% (of the rated voltage of motor 2)	0.0%

Function code	Name	Description	Default
P04.20	V/F frequency point 3 of motor 2	P04.18–P02.02 (Hz, P12.00=0) or P04.18–P02.16 (Hz, P12.00=0)	0.00Hz
P04.21	V/F voltage point 3 of motor 2	0.0%–110.0% (of the rated voltage of motor 2)	0.0%
P04.22	V/F slip compensation gain of motor 2	0.0–200.0%	100.0%
P04.23	Low-frequency oscillation control factor of motor 2	0–100	10
P04.24	High-frequency oscillation control factor of motor 2	0–100	10
P04.25	Oscillation control threshold of motor 2	0.00Hz–P00.03 (Max. output frequency)	30.00Hz
P04.26	Energy-saving run	0: Disable 1: Automatic energy-saving run	0
P04.27	Voltage setting channel selection	0: Keypad (output voltage is determined by P04.28) 1: AI1 2: AI2 3: AI3 4: HDIA 5: Multi-step speed running (The setting is determined by group P10.) 6: PID 7: Modbus/Modbus TCP communication 8: PROFIBUS/CANopen /BACnet MSTP communication 9: Ethernet communication 10: HDIB 11: PROFINET/EtherNet IP communication 12: Programmable card 13–17: Reserved 18: Keypad analog (valid for 1.5–22kW models)	0
P04.28	Voltage set through keypad	0.0%–100.0% (of the motor rated voltage)	100.0%
P04.29	Voltage increase time	0.0–3600.0s	5.0s

Function code	Name	Description	Default
P04.30	Voltage decrease time	0.0–3600.0s	5.0s
P04.31	Max. output voltage	P04.32–100.0% (of the motor rated voltage)	100.0%
P04.32	Min. output voltage	0.0%–P04.31 (relative to motor rated voltage)	0.0%
P04.33	Weakening coefficient in constant power zone	1.00–1.30	1.00
P04.34	Pull-in current 1 in SM V/F control	When the SM V/F control mode is enabled, the function code is used to set the reactive current of the motor when the output frequency is lower than the frequency specified by P04.36. Setting range: -100.0%→+100.0% (of the motor rated current)	20.0%
P04.35	Pull-in current 2 in SM V/F control	When the SM V/F control mode is enabled the function code is used to set the reactive current of the motor when the output frequency is greater than the frequency specified by P04.36. Setting range: -100.0%→+100.0% (of the motor rated current)	10.0%
P04.36	Frequency threshold for pull-in current switching in SM V/F control	When the SM V/F control mode is enabled, the function code is used to set the frequency threshold for the switching between pull-in current 1 and pull-in current 2. Setting range: 0.0 –200.0% (of the motor rated frequency)	20.0%
P04.37	Reactive current closed-loop proportional coefficient in SM V/F control	When the SM V/F control mode is enabled, the function code is used to set the proportional coefficient of reactive current closed-loop control. Setting range: 0–3000	50
P04.38	Reactive current closed-loop integral time in SM V/F control	When the SM V/F control mode is enabled, the function code is used to set the integral coefficient of reactive current closed-loop control. Setting range: 0–3000	30
P04.39	Reactive current closed-loop output limit in SM V/F	When the SM V/F control mode is enabled, the function code is used to set the output limit of the reactive current closed-loop control. A greater value	8000

Function code	Name	Description	Default
	control	indicates a higher reactive closed-loop compensation voltage and higher output power of the motor. In general, you do not need to modify the function code. Setting range: 0–16000	
P04.40	Enabling IF mode for AM 1	0: Invalid 1: Enable	0
P04.41	Current setting in IF mode for AM 1	When IF control is adopted for AM 1, the function code is used to set the output current. The value is a percentage in relative to the rated current of the motor. Setting range: 0.0–200.0%	120.0%
P04.42	Proportional coefficient in IF mode for AM 1	When IF control is adopted for AM 1, the function code is used to set the proportional coefficient of the output current closed-loop control. Setting range: 0–5000	350
P04.43	Integral coefficient in IF mode for AM 1	When IF control is adopted for AM 1, the function code is used to set the integral coefficient of the output current closed-loop control. Setting range: 0–5000	150
P04.44	Starting frequency point for switching off IF mode for AM 1	0.00Hz–P04.50	10.00Hz
P04.45	Enabling IF mode for AM 2	0: Invalid 1: Enable	0
P04.46	Current setting in IF mode for AM 2	When IF control is adopted for AM 2, the function code is used to set the output current. The value is a percentage in relative to the rated current of the motor. Setting range: 0.0–200.0%	120.0%
P04.47	Proportional coefficient in IF mode for AM 2	When IF control is adopted for AM 2, the function code is used to set the proportional coefficient of output current closed-loop control. Setting range: 0–5000	350
P04.48	Integral coefficient in IF mode for AM 2	When IF control is adopted for AM 2, the function code is used to set the integral coefficient of output current closed-loop control. Setting range: 0–5000	150
P04.49	Starting frequency	0.00Hz–P04.51	10.00Hz

Function code	Name	Description	Default
	point for switching off IF mode for AM 2		
P04.50	End frequency point for switching off IF mode for AM 1	P04.44–P00.03	25.00Hz
P04.51	End frequency point for switching off IF mode for AM 2	P04.49–P00.03	25.00Hz
P04.52	VF energy-saving mode selection	0: Max. efficiency (default) 1: Optimal power factor 2: MTPA	0
P04.53	VF energy-saving gain coefficient	0.0–400.0%	100.0%
P04.54	VF energy-saving power angle gain coefficient	0.0–200.0%	80.0%

5.5.5 Torque control

The VFD supports torque control and speed control. Speed control aims to stabilize the speed to keep the set speed consistent with the actual running speed, meanwhile, the max. load-carrying capacity is restricted by the torque limit. Torque control aims to stabilize the torque to keep the set torque consistent with the actual output torque, meanwhile, the output frequency is restricted by the upper and lower limits.

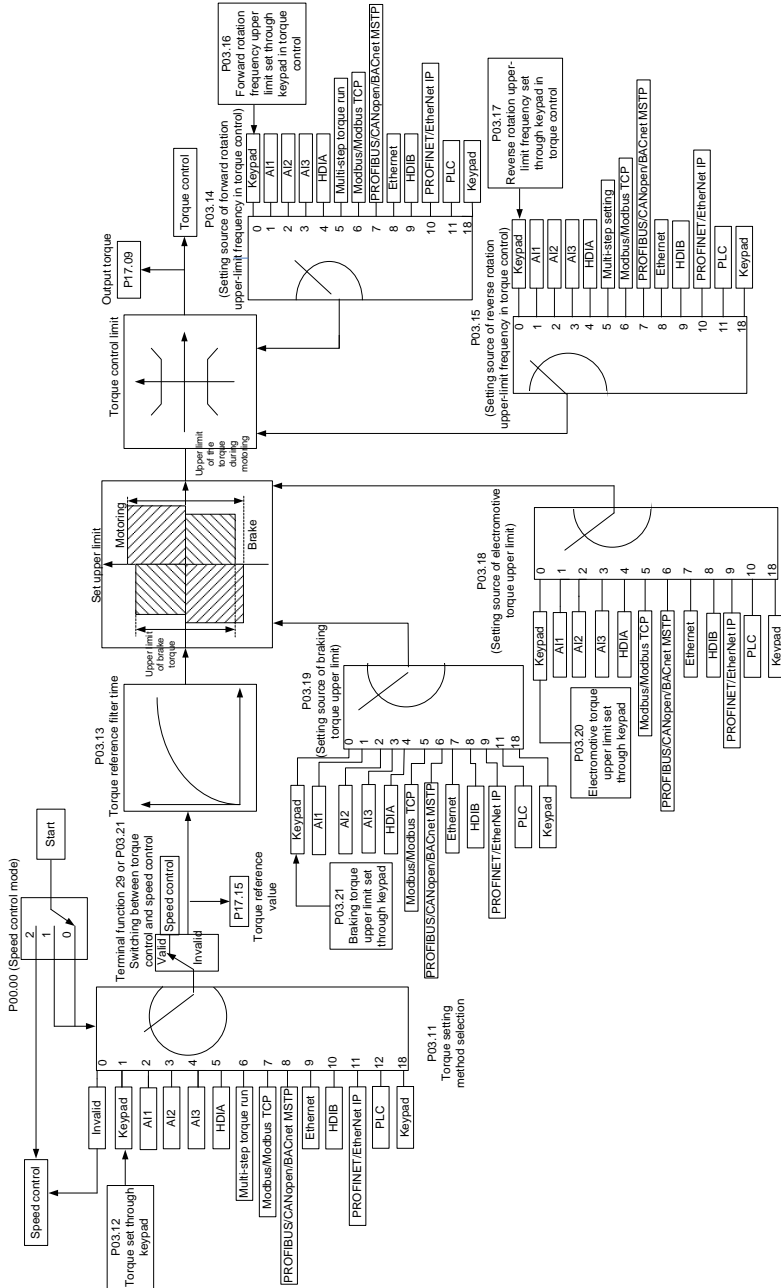



Related function parameters

Function code	Name	Description	Default
P00.00	Speed control mode	0: SVC mode 0 1: SVC mode 1 2: Space voltage vector control mode Note: Before using a vector control mode (0 or 1), enable the VFD to perform motor parameter autotuning first.	2
P03.32	Enabling torque control	0: Disable 1: Enable	0
P03.11	Torque setting method selection	1: Keypad (P03.12) 2: AI1 3: AI2 4: AI3 5: Pulse frequency HDIA 6: Multi-step torque 7: Modbus/Modbus TCP communication 8: PROFIBUS/CANopen/BACnet MSTP communication 9: Ethernet communication 10: Pulse frequency HDIB 11: PROFINET/EtherNet IP communication 12: Programmable card 13–17: Reserved 18: Keypad analog (valid for 1.5–22kW models) Note: 100% corresponds to the motor rated current.	0
P03.12	Torque set through keypad	-300.0%–300.0% (of the motor rated current)	50.0%
P03.13	Torque reference filter time	0.000–10.000s	0.010s
P03.14	Setting source of forward rotation upper-limit frequency in torque control	0: Keypad (P03.16) 1: AI1 (100% corresponds to the max. frequency) 2: AI2 (same as the above) 3: AI3 (same as the above) 4: Pulse frequency HDIA 5: Multi-step setting (same as the above) 6: Modbus/Modbus TCP communication (same as the above) 7: PROFIBUS/CANopen/BACnet MSTP	0

Function code	Name	Description	Default
		communication (same as the above) 8: Ethernet communication (same as the above) 9: Pulse frequency HDIB (same as the above) 10: PROFINET/EtherNet IP communication (same as the above) 11: Programmable card (same as the above) 12–17: Reserved 18: Keypad analog (valid for 1.5–22kW models)	
P03.15	Setting source of reverse rotation upper-limit frequency in torque control	0: Keypad (P03.17) 1: AI1 (100% corresponds to the max. frequency) 2: AI2 (same as the above) 3: AI3 (same as the above) 4: Pulse frequency HDIA 5: Multi-step setting (same as the above) 6: Modbus/Modbus TCP communication (same as the above) 7: PROFIBUS/CANopen/BACnet MSTP communication (same as the above) 8: Ethernet communication (same as the above) 9: Pulse frequency HDIB (same as the above) 10: PROFINET/EtherNet IP communication (same as the above) 11: Programmable card (same as the above) 12–17: Reserved 18: Keypad analog (valid for 1.5–22kW models)	0
P03.16	Forward rotation frequency upper limit set through keypad in torque control	0.00Hz–P00.03 (Max. output frequency)	50.00Hz
P03.17	Reverse rotation upper-limit frequency set through keypad in torque control	0.00Hz–P00.03 (Max. output frequency)	50.00Hz
P03.18	Setting source of electromotive torque upper limit	0: Keypad (P03.20) 1: AI1 (100% corresponding to the motor rated current)	0

Function code	Name	Description	Default
		2: AI2 (same as the above) 3: AI3 (same as the above) 4: Pulse frequency HDIA 5: Modbus/Modbus TCP communication 6: PROFIBUS/CANopen/BACnet MSTP communication 7: Ethernet communication 8: Pulse frequency HDIB 9: PROFINET/EtherNet IP communication 10: Programmable card 11–17: Reserved 18: Keypad analog (valid for 1.5–22kW models)	
P03.19	Setting source of braking torque upper limit	0: Keypad (P03.21) 1: AI1 2: AI2 3: AI3 4: Pulse frequency HDIA 5: Modbus/Modbus TCP communication 6: PROFIBUS/CANopen/BACnet MSTP communication 7: Ethernet communication 8: Pulse frequency HDIB 9: PROFINET/EtherNet IP communication 11: Programmable card 12–17: Reserved 18: Keypad analog (valid for 1.5–22kW models) Note: 100% corresponds to the motor rated current.	0
P03.20	Electromotive torque upper limit set through keypad	0.0–300.0% (of the motor rated current)	180.0%
P03.21	Braking torque upper limit set through keypad	0.0–300.0% (of the motor rated current)	180.0%
P17.09	Motor output torque	-250.0%–250.0%	0.0%
P17.15	Torque reference value	-300.0%–300.0% (of the motor rated current)	20.0%

5.5.6 Motor parameters

	<ul style="list-style-type: none"> ◇ Check the safety conditions surrounding the motor and load machineries before autotuning as physical injury may occur due to sudden start of motor during autotuning. ◇ Although the motor does not run during static autotuning, the motor is still supplied with power. Do not touch the motor during autotuning; otherwise, electric shock may occur. Do not touch the motor before autotuning is completed.
	<ul style="list-style-type: none"> ◇ If the motor has been connected to a load, do not carry out rotary autotuning. Otherwise, the VFD may malfunction or may be damaged. If rotary autotuning is carried out on a motor which has been connected to a load, incorrect motor parameter settings and motor action exceptions may occur. Disconnect from the load to carry out autotuning if necessary.

The VFD can drive both asynchronous motors and synchronous motors, and it supports two sets of motor parameters, which can be switched over by multifunction digital input terminals or communication means.

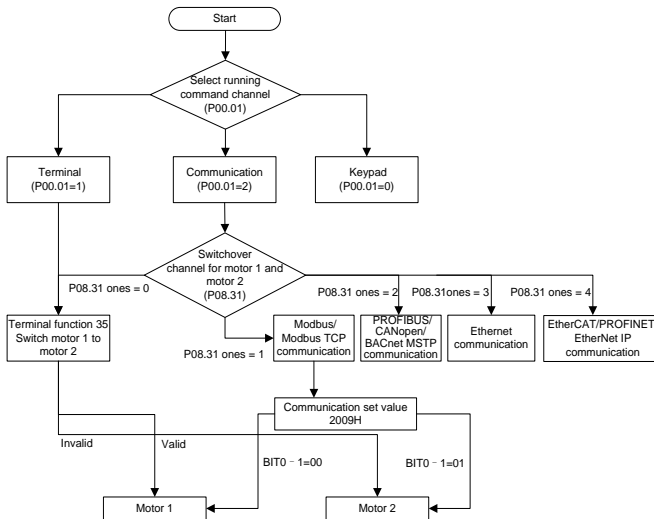

The control performance of the VFD is based on accurate motor models. Therefore, you need to carry out motor parameter autotuning before running a motor for the first time (taking motor 1 as an example).

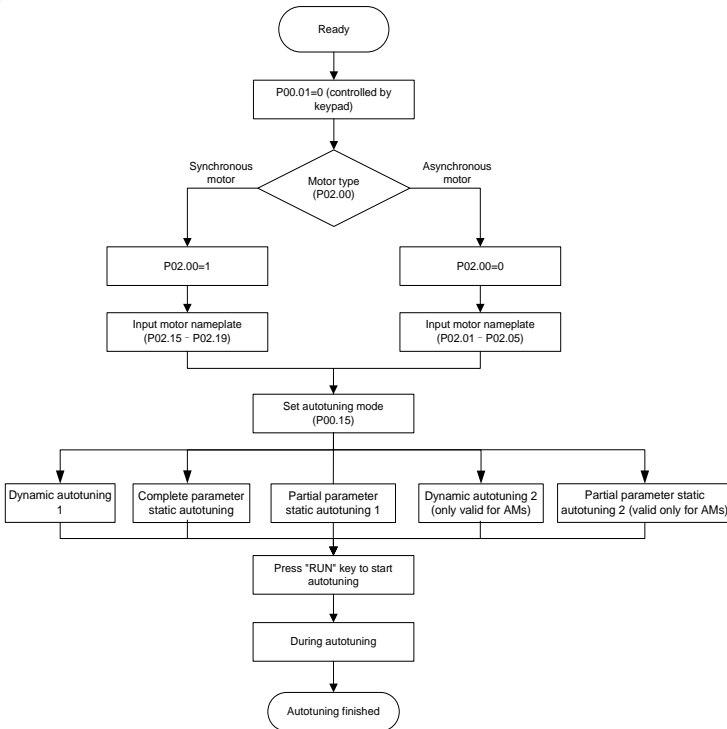

Note:

- ✧ Motor parameters must be set correctly according to the motor nameplate.
- ✧ If rotary autotuning is selected during motor autotuning, disconnect the motor from the load to put the motor in static and no-load state. Otherwise, the motor parameter autotuning results may be incorrect. In addition, autotune P02.06–P02.10 for AMs and autotune P02.20–P02.23 for SMs.
- ✧ If static autotuning is selected for motor autotuning, there is no need to disconnect the motor from the load, but the control performance may be impacted as only a part of the motor parameters have been autotuned. In addition, autotune P02.06–P02.10 for AMs and autotune P02.20–P02.22 for SMs. P02.23 can be obtained through calculation.
- ✧ Motor autotuning can be carried out on the present motor only. If you need to perform autotuning on the other motor, switch the motor through selecting the switch-over channel of motor 1 and motor 2 by setting the ones place of P08.31.

Related function parameters

Function code	Name	Description	Default
P00.01	Channel of running commands	0: Keypad 1: Terminal 2: Communication	0
P00.15	Motor parameter autotuning	0: No operation 1: Dynamic autotuning 1 Comprehensive motor parameter autotuning. It is recommended to use rotating autotuning when high control accuracy is required. 2: Complete parameter static autotuning Used in scenarios where the motor cannot be disconnected from load. 3: Partial parameter static autotuning 1 When the present motor is motor 1, only P02.06, P02.07, and P02.08 are autotuned; when the present motor is motor 2, only P12.06, P12.07, and P12.08 are autotuned. 4: Dynamic autotuning 2; similar to dynamic autotuning 1, but only valid for AMs 5: Partial parameter static autotuning 2 (valid only for AMs)	0
P02.00	Type of motor 1	0: Asynchronous motor (AM) 1: Synchronous motor (SM)	0
P02.01	Rated power of AM 1	0.1–3000.0kW	Model depended
P02.02	Rated frequency of AM 1	0.01Hz–P00.03 (Max. output frequency)	50.00Hz
P02.03	Rated speed of AM 1	1–60000rpm	Model depended
P02.04	Rated voltage of AM 1	0–1200V	Model depended
P02.05	Rated current of AM 1	0.8–6000.0A	Model depended
P02.06	Stator resistance of AM 1	0.001–65.535Ω	Model depended
P02.07	Rotor resistance of AM 1	0.001–65.535Ω	Model depended

Function code	Name	Description	Default
P02.08	Leakage inductance of AM 1	0.1–6553.5mH	Model depended
P02.09	Mutual inductance of AM 1	0.1–6553.5mH	Model depended
P02.10	No-load current of AM 1	0.1–6553.5A	Model depended
P02.15	Rated power of SM 1	0.1–3000.0kW	Model depended
P02.16	Rated frequency of SM 1	0.01Hz–P00.03 (Max. output frequency)	50.00Hz
P02.17	Number of pole pairs of SM 1	1–50	2
P02.18	Rated voltage of SM 1	0–1200V	Model depended
P02.19	Rated current of SM 1	0.8–6000.0A	Model depended
P02.20	Stator resistance of SM 1	0.001–65.535Ω	Model depended
P02.21	Direct-axis inductance of SM 1	0.01–655.35mH	Model depended
P02.22	Quadrature-axis inductance of SM 1	0.01–655.35mH	Model depended
P02.23	Counter-emf constant of SM 1	0–10000	300
P05.01–P05.06	Function selection of multifunction digital input terminals (S1–S4, and HDIA)	35: Switch from motor 1 to motor 2	0
P08.31	Switching between motor 1 and motor 2	0x00–0x14 Ones place: Switchover channel 0: Terminal 1: Modbus/Modbus TCP communication 2: PROFIBUS/CANopen /BACnet MSTP communication 3: Ethernet communication 4: PROFINET/EtherNet IP communication Tens place: indicates whether to enable switchover during running	0x00

Function code	Name	Description	Default
		0: Disable 1: Enable	
P12.00	Type of motor 2	0: Asynchronous motor (AM) 1: Synchronous motor (SM)	0
P12.01	Rated power of AM 2	0.1–3000.0kW	Model depended
P12.02	Rated frequency of AM 2	0.01Hz–P00.03 (Max. output frequency)	50.00Hz
P12.03	Rated speed of AM 2	1–60000rpm	Model depended
P12.04	Rated voltage of AM 2	0–1200V	Model depended
P12.05	Rated current of AM 2	0.8–6000.0A	Model depended
P12.06	Stator resistance of AM 2	0.001–65.535Ω	Model depended
P12.07	Rotor resistance of AM 2	0.001–65.535Ω	Model depended
P12.08	Leakage inductance of AM 2	0.1–6553.5mH	Model depended
P12.09	Mutual inductance of AM 2	0.1–6553.5mH	Model depended
P12.10	No-load current of AM 2	0.1–6553.5A	Model depended
P12.15	Rated power of SM 2	0.1–3000.0kW	Model depended
P12.16	Rated frequency of SM 2	0.01Hz–P00.03 (Max. output frequency)	50.00Hz
P12.17	Number of pole pairs of SM 2	1–50	2
P12.18	Rated voltage of SM 2	0–1200V	Model depended
P12.19	Rated current of SM 2	0.8–6000.0A	Model depended
P12.20	Stator resistance of SM 2	0.001–65.535Ω	Model depended
P12.21	Direct-axis inductance of	0.01–655.35mH	Model

Function code	Name	Description	Default
	SM 2		depended
P12.22	Quadrature-axis inductance of SM 2	0.01–655.35mH	Model depended
P12.23	Counter-emf constant of SM 2	0–10000	300

5.5.7 Start/stop control

The start/stop control of the VFD involves three states: start after a running command is given at power-on; start after power-off restart is effective; start after automatic fault reset. The three start/stop control states are described in the following.

There are three start modes for the VFD, which are start at starting frequency, start after DC braking, and start after speed tracking. You can select the proper start mode based on actual conditions.

For large-inertia load, especially in cases where reversal may occur, you can choose to start after DC braking or start after speed tracking.

Note: It is recommended to drive SMs in direct start mode.

1. Logic diagram for start after a running command is given at power-on

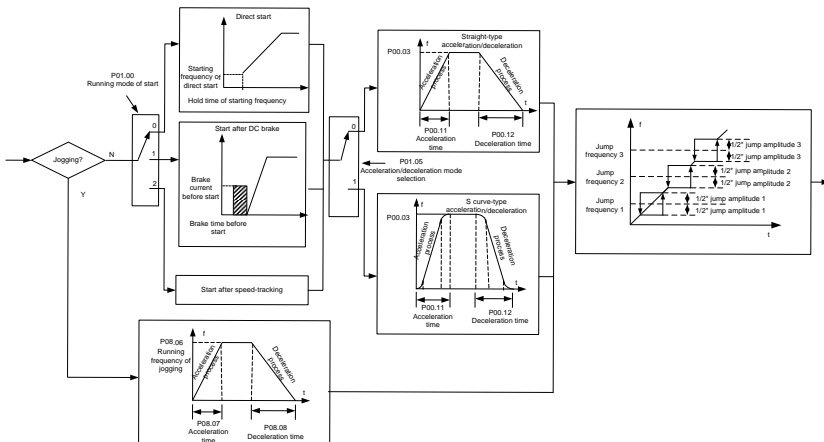

2. Logic diagram for start after power-off restart is effective

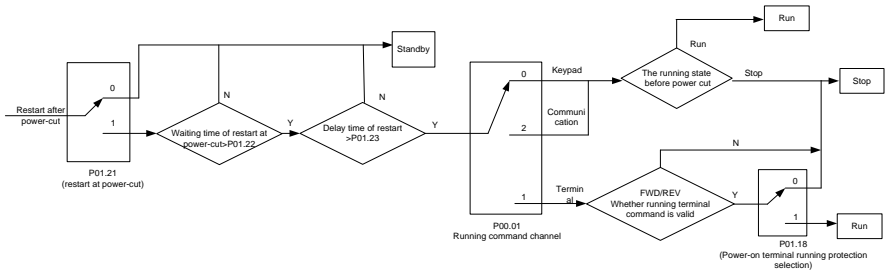

3. Logic diagram for start after automatic fault reset

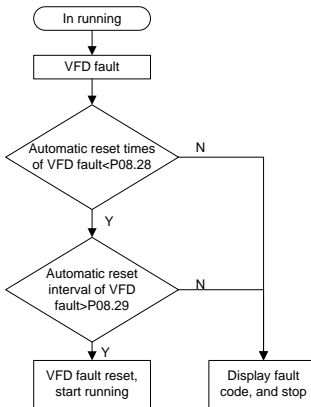

Related function parameters

Function code	Name	Description	Default
P00.01	Channel of running commands	0: Keypad 1: Terminal 2: Communication	0
P00.11	ACC time 1	0.0–3600.0s	Model depended
P00.12	DEC time 1	0.0–3600.0s	Model depended
P01.00	Running mode of start	0: Direct start 1: Start after DC braking 2: Start after speed tracking Note: For AMs, speed tracking is not supported in SVC 0, and software speed tracking is supported in other modes. For details, see	0

Function code	Name	Description	Default
		parameters P01.35–P01.41. For SMs, you do not need to modify parameters P01.35–P01.41.	
P01.01	Starting frequency of direct start	0.00–50.00Hz	0.50Hz
P01.02	Hold time of starting frequency	0.0–50.0s	0.0s
P01.03	Braking current before start	0.0–100.0%	0.0%
P01.04	DC braking time before start	0.00–50.00s	0.00s
P01.05	ACC/DEC mode	0: Linear 1: S curve Note: If mode 1 is selected, set P01.06, P01.07, P01.27, and P01.28 accordingly.	0
P01.08	Stop mode	0: Decelerate to stop 1: Coast to stop	0
P01.09	Starting frequency of braking for stop	0.00Hz–P00.03 (Max. output frequency)	0.00Hz
P01.10	Wait time before DC braking for stop	0.00–50.00s	0.00s
P01.11	DC braking current for stop	0.0–100.0%	0.0%
P01.12	DC braking time for stop	0.00–50.00s	0.00s
P01.13	FWD/REV run deadzone time	0.0–3600.0s	0.0s
P01.14	FWD/REV run switching mode	0: Switch at zero frequency 1: Switch at the starting frequency 2: Switch after the speed reaches the stop speed with a delay	0
P01.15	Stop speed	0.00–100.00Hz	0.50 Hz
P01.16	Stop speed detection mode	0: Detect by the set speed (unique in V/F mode) 1: Detect by the feedback speed	1
P01.18	Terminal-based running command protection at power-on	0: The terminal running command is invalid at power-on 1: The terminal running command is valid at power-on	0
P01.19	Action selected when running frequency less	0: Run at the frequency lower limit 1: Stop	0

Function code	Name	Description	Default
	than frequency lower limit (valid when frequency lower limit greater than 0)	2: Sleep	
P01.20	Wake-up-from-sleep delay	0.0–3600.0s (valid only when P01.19=2)	0.0s
P01.21	Power-off restart selection	0: Disable 1: Enable	0
P01.22	Wait time for restart after power-off	0.0–3600.0s (valid only when P01.21=1)	1.0s
P01.23	Start delay time	0.0–60.0s	0.0s
P01.24	Stop speed delay	0.0–100.0s	0.0s
P01.25	Open-loop 0Hz output selection	0: Output without voltage 1: Output with voltage 2: Output with the DC braking current for stop	0
P01.26	DEC time for emergency stop	0.0–60.0s	2.0s
P01.27	Time of starting segment of DEC S curve	0.0–50.0s	0.1s
P01.28	Time of ending segment of DEC S curve	0.0–50.0s	0.1s
P01.29	Short-circuit braking current	0.0–150.0% (of the VFD rated output current)	0.0%
P01.30	Hold time of short-circuit braking for start	0.00–50.00s	0.00s
P01.31	Hold time of short-circuit braking for stop	0.00–50.00s	0.00s
P01.32	Pre-exciting time for jogging	0.000–10.000s	0.300s
P01.33	Starting frequency of braking for stop in jogging	0.00Hz–P00.03	0.00Hz
P01.34	Sleep delay	0.0–3600.0s	0.0s
P05.01–P05.06	Digital input function selection	1: Run forward 2: Run reversely 4: Jog forward 5: Jog reversely 6: Coast to stop 7: Fault reset 8: Pause running 21: ACC/DEC time selection 1 22: ACC/DEC time selection 2	

Function code	Name	Description	Default
		30: Disable ACC/DEC	
P08.00	ACC time 2	0.0–3600.0s	Model depended
P08.01	DEC time 2	0.0–3600.0s	Model depended
P08.02	ACC time 3	0.0–3600.0s	Model depended
P08.03	DEC time 3	0.0–3600.0s	Model depended
P08.04	ACC time 4	0.0–3600.0s	Model depended
P08.05	DEC time 4	0.0–3600.0s	Model depended
P08.06	Running frequency of jog	0.00Hz–P00.03 (Max. output frequency)	5.00Hz
P08.07	ACC time for jogging	0.0–3600.0s	Model depended
P08.08	DEC time for jogging	0.0–3600.0s	Model depended
P08.19	Switching frequency of ACC/DEC time	0.00–P00.03 (Max. output frequency) 0.00Hz, no switchover. If the running frequency is greater than P08.19, switch to ACC/DEC time 2.	0.00Hz
P08.21	Reference frequency of ACC/DEC time	0: Max. output frequency 1: Set frequency 2: 100Hz Note: Valid only for straight-line ACC/DEC	0
P08.28	Auto fault reset count	0–10	0
P08.29	Auto fault reset interval	0.1–3600.0s	1.0s

5.5.8 Frequency setting

The VFD supports multiple kinds of frequency reference modes, which can be categorized into two types: main reference channel and auxiliary reference channel.

There are two main reference channels, namely frequency reference channel A and frequency reference channel B. These two channels support simple arithmetical operation between each other, and they can be switched dynamically by setting multifunction terminals.

There is one input mode for auxiliary reference channel, namely terminal **UP/DOWN** switch input. By setting function codes, you can enable the corresponding reference mode and the impact made on the VFD frequency reference by this reference mode.

The VFD actual reference is comprised of the main reference channel and auxiliary reference channel.

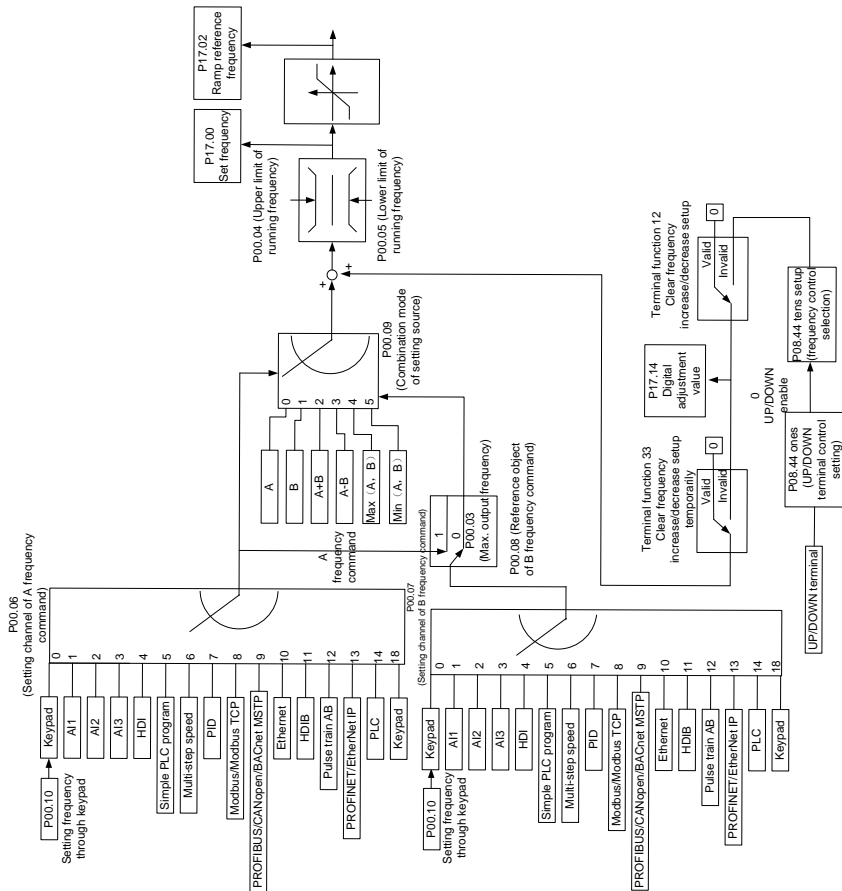

The VFD supports switchover between different reference channels, and the rules for channel switchover are shown as follows.

Present reference channel P00.09	Multifunction terminal function 13 (Switch from channel A to channel B)	Multifunction terminal function 14 (Switch from combined setting to channel A)	Multifunction terminal function 15 (Switch from combined setting to channel B)
A	B	/	/
B	A	/	/
A+B	/	A	B

Present reference channel P00.09	Multifunction terminal function 13 (Switch from channel A to channel B)	Multifunction terminal function 14 (Switch from combined setting to channel A)	Multifunction terminal function 15 (Switch from combined setting to channel B)
A-B	/	A	B
Max(A, B)	/	A	B
Min(A, B)	/	A	B

Note: "/" indicates this multifunction terminal is invalid under present reference channel.

When setting the auxiliary frequency inside the VFD through multifunction terminals UP (10) and DOWN (11), you can increase/decrease the frequency quickly by setting P08.45 (UP terminal frequency incremental change rate) and P08.46 (DOWN terminal frequency decremental change rate).

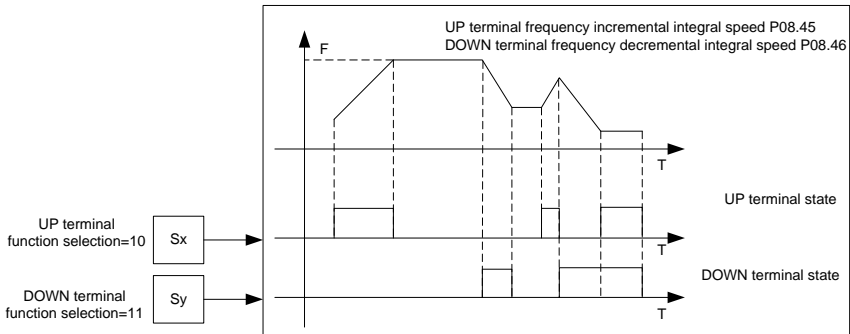

Related function parameters

Function code	Name	Description	Default
P00.03	Max. output frequency	P00.04–400.00Hz	50.00Hz
P00.04	Upper limit of running frequency	P00.05–P00.03	50.00Hz
P00.05	Lower limit of running frequency	0.00Hz–P00.04	0.00Hz
P00.06	Setting channel of A frequency command	0: Keypad 1: AI1	0
P00.07	Setting channel of B frequency command	2: AI2 3: AI3 4: High-speed pulse HDIA 5: Simple PLC program	15

Function code	Name	Description	Default
		6: Multi-step speed running 7: PID control 8: Modbus/Modbus TCP communication 9: PROFIBUS/CANopen /BACnet MSTP communication 10: Ethernet communication 11: High-speed pulse HDIB 12: Pulse train AB 13: PROFINET/EtherNet IP communication 14: Programmable card 15–17: Reserved 18: Keypad analog (valid for 1.5–22kW models)	
P00.08	Reference object of B frequency command	0: Max. output frequency 1: A frequency command	0
P00.09	Combination mode of setting source	0: A 1: B 2: (A+B) 3: (A-B) 4: Max(A, B) 5: Min(A, B)	0
P05.01– P05.06	Function selection of multifunction digital input terminals (S1–S4, and HDIA)	10: Increase frequency setting (UP) 11: Decrease frequency setting (DOWN) 12: Clear the frequency increase/decrease setting 13: Switch between A setting and B setting 14: Switch between combination setting and A setting 15: Switch between combination setting and B setting	
P08.42	Keypad digital control setting	0x0000–0x1223 Ones place: Frequency setting selection 0: Both the UP/DOWN key and digital potentiometer can be used for the control. 1: Only control through the UP/ DOWN key is valid. 2: Only control through the digital potentiometer is valid.	0x0000

Function code	Name	Description	Default
		<p>3: Controls through the UP/ DOWN key and digital potentiometer are invalid.</p> <p>Tens place: Frequency control selection</p> <p>0: Valid only when P00.06=0 or P00.07=0</p> <p>1: Valid for all frequency setting methods</p> <p>2: Invalid for multi-step speed running when multi-step speed running has the priority</p> <p>Hundreds place: Action selection for stop</p> <p>0: Setting is valid.</p> <p>1: Valid during running, cleared after stop</p> <p>2: Valid during running, cleared after a stop command is received</p> <p>Thousands place: Indicates whether to enable the integral function through the UP/DOWN key and digital potentiometer.</p> <p>0: Enable the integral function</p> <p>1: Disable the integral function</p> <p>Note: It is valid for LED keypad.</p>	
P08.43	Keypad digital potentiometer integral rate	0.01–10.00s	0.10s
P08.44	UP/DOWN terminal control setting	<p>0x000–0x221</p> <p>Ones place: Frequency setting selection</p> <p>0: The setting made through UP/DOWN is valid.</p> <p>1: The setting made through UP/DOWN is invalid.</p> <p>Tens place: Frequency control selection</p> <p>0: Valid only when P00.06=0 or P00.07=0</p> <p>1: Valid for all frequency setting methods</p> <p>2: Invalid for multi-step speed running when multi-step speed running has the priority</p> <p>Hundreds place: Action selection for stop</p> <p>0: Setting is valid.</p> <p>1: Valid during running, cleared after stop</p> <p>2: Valid during running, cleared after a stop command is received</p>	0x000
P08.45	Frequency increment change rate of the UP terminal	<p>0.01–50.00Hz/s</p> <p>Note: The value is also used as the frequency increment or decrement that is made by pressing</p>	0.50Hz/s

Function code	Name	Description	Default
		the UP/DOWN key on the LCD keypad.	
P08.46	Frequency reduce rate of the DOWN terminal	0.01–50.00Hz/s	0.50Hz/s
P17.00	Set frequency	0.00Hz–P00.03 (Max. output frequency)	0.00Hz
P17.02	Ramp reference frequency	0.00Hz–P00.03 (Max. output frequency)	0.00Hz
P17.14	Digital adjustment value	0.00Hz–P00.03 (Max. output frequency)	0.00Hz

5.5.9 Analog input

The VFD carries two analog input terminals AI1 and AI2, in which AI1 supports the range of 0(2)–10V/0(4)–20mA (whether AI1 uses voltage input or current input can be set by P05.50; when AI1 uses current input, change the AI1 jumper cap on the control board from V to I) and AI2 supports the range of -10–+10V), and one high-speed pulse input terminal. Each input can be filtered separately, and the corresponding reference curve can be set by adjusting the reference corresponds to the max. value and min. value.

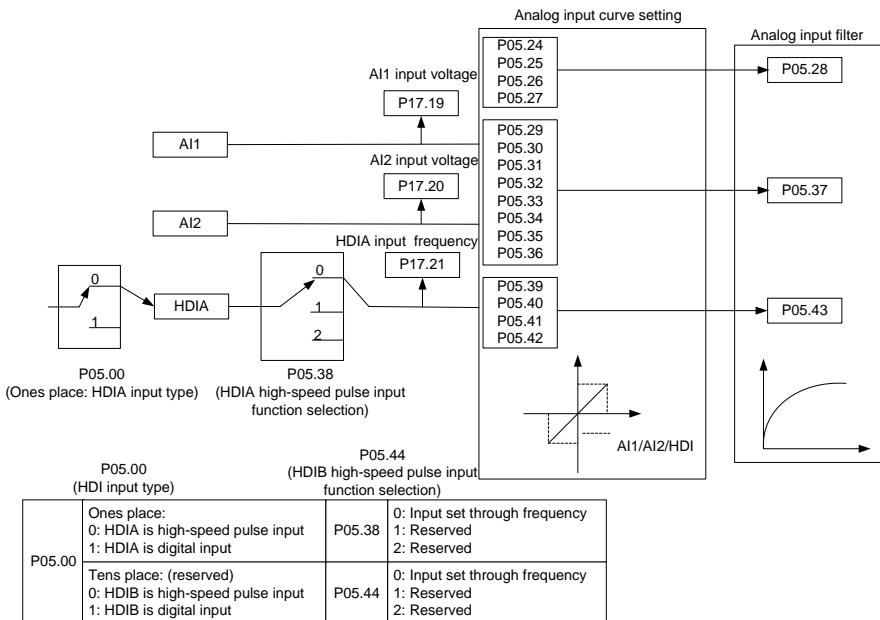

Related function parameters

Function code	Name	Description	Default
P05.00	HDI input type	0x00–0x11 Ones place: HDIA input type 0: HDIA is high-speed pulse input 1: HDIA is digital input Tens place: HDIB input type (reserved) 0: HDIB is high-speed pulse input (reserved) 1: HDIB is digital input (reserved)	0x00
P05.24	AI1 lower limit	0.00V–P05.26	0.00V
P05.25	Corresponding setting of AI1 lower limit	-300.0%–300.0%	0.0%
P05.26	AI1 upper limit	P05.24–10.00V	10.00V
P05.27	Corresponding setting of AI1 upper limit	-300.0%–300.0%	100.0%
P05.28	AI1 input filter time	0.000s–10.000s	0.100s
P05.29	AI2 lower limit	-10.00V–P05.31	-10.00V
P05.30	Corresponding setting of AI2 lower limit	-300.0%–300.0%	-100.0%
P05.31	AI2 middle value 1	P05.29–P05.33	0.00V
P05.32	Corresponding setting of AI2 middle value 1	-300.0%–300.0%	0.0%
P05.33	AI2 middle value 2	P05.31–P05.35	0.00V
P05.34	Corresponding setting of AI2 middle value 2	-300.0%–300.0%	0.0%
P05.35	AI2 upper limit	P05.33–10.00V	10.00V
P05.36	Corresponding setting of AI2 upper limit	-300.0%–300.0%	100.0%
P05.37	AI2 input filter time	0.000s–10.000s	0.100s
P05.38	HDIA high-speed pulse input function selection	0: Input set through frequency	0
P05.39	HDIA frequency lower limit	0.000kHz–P05.41	0.000kHz
P05.40	Corresponding setting of HDIA frequency lower limit	-300.0%–300.0%	0.0%
P05.41	HDIA frequency upper limit	P05.39–50.000kHz	50.000kHz
P05.42	Corresponding setting of HDIA upper limit frequency	-300.0%–300.0%	100.0%

Function code	Name	Description	Default
P05.43	HDIA frequency input filter time	0.000s–10.000s	0.030s
P05.50	A11 input signal type	0x00–0x11 Ones place: Input signal type 0: Voltage 1: Current Tens place: Input value unit selection 0: All voltage type 1: Voltage for voltage-type input, current for current-type input Note: After selecting voltage and current inputs for the function code, you also need to install the jumper on the control board in the correct position.	0x00

5.5.10 Analog output

The VFD carries two analog output terminals (0–10V/0–20mA) and one high-speed pulse output terminal. Analog output signals can be filtered separately, and the proportional relation can be adjusted by setting the max. value, min. value, and the percentage of their corresponding output. Analog output signal can output motor speed, output frequency, output current, motor torque and motor power at a certain proportion.

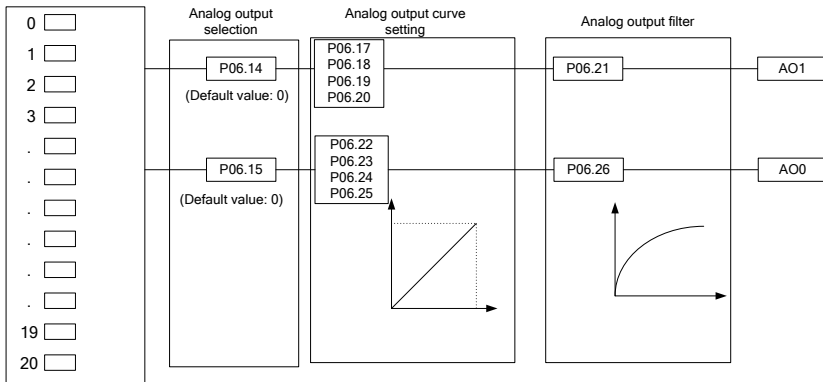

AO output relationship description:

(The min. value and max. value of the output correspond to 0.0% and 100.00% of the pulse or analog default output. The actual output voltage or pulse frequency corresponds to the actual percentage, which can be set through function codes.)

Setting	Function	Description
0	Running frequency	0–Max. output frequency
1	Set frequency	0–Max. output frequency
2	Ramp reference frequency	0–Max. output frequency
3	Rotational speed	0–Synchronous speed corresponding to max. output frequency
4	Output current (relative to the VFD)	0–Twice the VFD rated current
5	Output current (relative to motor)	0–Twice the motor rated current
6	Output voltage	0–1.5 times the VFD rated voltage
7	Output power	0–Twice the motor rated power
8	Set torque value (bipolar)	0–Twice the motor rated current. A negative value corresponds to 0.0% by default.
9	Output torque (absolute value)	0–±(Twice the motor rated torque)
10	AI1 input	0–10V/0–20mA
11	AI2 input	0V–10V. A negative value corresponds to 0.0% by default.
12	AI3 input	0–10V/0–20mA
13	High-speed pulse HDIA input	0.00–50.00kHz
14	Value 1 set through Modbus communication	0–1000
15	Value 2 set through Modbus communication	0–1000
16	Value 1 set through PROFIBUS/CANopen /BACnet MSTP communication	0–1000
17	Value 2 set through PROFIBUS/CANopen communication	0–1000
18	Value 1 set through Ethernet communication	0–1000
19	Value 2 set through Ethernet communication	0–1000
20	HDIB input value	0.00–50.00kHz
21	Value 1 set through PROFINET/EtherNet IP communication	0–1000. A negative value corresponds to 0.0% by default.
22	Torque current (bipolar)	0–Three times the motor rated current. A negative value corresponds to 0.0% by default.
23	Exciting current	0–Three times the motor rated current. A

Setting	Function	Description
		negative value corresponds to 0.0% by default.
24	Set frequency (bipolar)	0–Max. output frequency. A negative value corresponds to 0.0% by default.
25	Ramp reference frequency (bipolar)	0–Max. output frequency. A negative value corresponds to 0.0% by default.
26	Rotational speed (bipolar)	0–Synchronous rotation speed corresponding to max. output frequency. A negative value corresponds to 0.0% by default.
27	Value 2 set through PROFINET/EtherNet IP communication	0–1000
28	C_AO1 from CODESYS (Set P27.00 to 1.)	
29	C_AO2 from CODESYS (Set P27.00 to 1.)	
30	Rotational speed	0–Twice the motor rated synchronous rotation speed
31	Output torque (bipolar)	0–Twice the motor rated torque. A negative value corresponds to 0.0% by default.
32	PID1 output	
33	PID2 output	
34	PID1 reference value	
35	PID1 feedback value	
36	PID2 reference value	
37	PID2 feedback value	
40	Value 0 set through PROFIBUS/CANopen /BACnet MSTP communication	
41	Value 0 set through PROFINET/EtherNet IP communication	

Related function parameters

Function code	Name	Description	Default
P06.14	AO1 output	0–47	0
P06.15	AO0 output	0: Running frequency	0
P06.16	Reserved	1: Set frequency 2: Ramp reference frequency	0

Function code	Name	Description	Default
		3: Rotational speed 4: Output current (relative to the VFD) 5: Output current (relative to the motor) 6: Output voltage 7: Output power 8: Set torque 9: Output torque 10: AI1 input 11: AI2 input value 12: AI3 input value 13: High-speed pulse HDIA input 14: Value 1 set through Modbus communication 15: Value 2 set through Modbus communication 16: Value 1 set through PROFIBUS/CANopen /BACnet MSTP communication 17: Value 2 set through PROFIBUS/CANopen communication 18: Value 1 set through Ethernet communication 19: Value 2 set through Ethernet communication 20: HDIB input value 21: Value 1 set through PROFINET/EtherNet IP communication 22: Torque current (bipolar, 100% corresponding to 10V) 23: Exciting current (100% corresponding to 10V) 24: Set frequency (bipolar) 25: Ramp reference frequency (bipolar) 26: Rotational speed (bipolar) 27: Value 2 set through PROFINET/EtherNet IP communication 28: C_AO1 from CODESYS (Set P27.00 to 1.) 29: C_AO2 from CODESYS (Set P27.00 to 1.) 30: Rotational speed 31: Output torque 32: PID1 output 33: PID2 output 34: PID1 reference value 35: PID1 feedback value	

Function code	Name	Description	Default
		36: PID2 reference value 37: PID2 feedback value 38–39: Reserved 40: Value 0 set through PROFIBUS/CANopen /BACnet MSTP communication 41: Value 0 set through PROFINET/EtherNet IP communication 42–47: Reserved	
P06.17	AO1 output lower limit	-300.0%–P06.19	0.0%
P06.18	AO1 output corresponding to lower limit	0.00V–10.00V	0.00V
P06.19	AO1 output upper limit	P06.17–300.0%	100.0%
P06.20	AO1 output corresponding to upper limit	0.00V–10.00V	10.00V
P06.21	AO1 output filter time	0.000s–10.000s	0.000s
P06.22	AO0 output lower limit	-300.0%–P06.23	0.0%
P06.23	AO0 output corresponding to lower limit	0.00V–10.00V	0.00V
P06.24	AO0 output upper limit	P06.35–300.0%	100.0%
P06.25	AO0 output corresponding to upper limit	0.00V–10.00V	10.00V
P06.26	AO0 output filter time	0.000s–10.000s	0.000s

5.5.11 Digital input

The VFD carries four programmable digital input terminals and two HDI input terminals. The function of all the digital input terminals can be programmed through function codes. HDI input terminal can be set to act as high-speed pulse input terminal or common digital input terminal; if it is set to act as a high-speed pulse input terminal, you can also set HDIA high-speed pulse input to serve as the

frequency reference and encoder signal input.

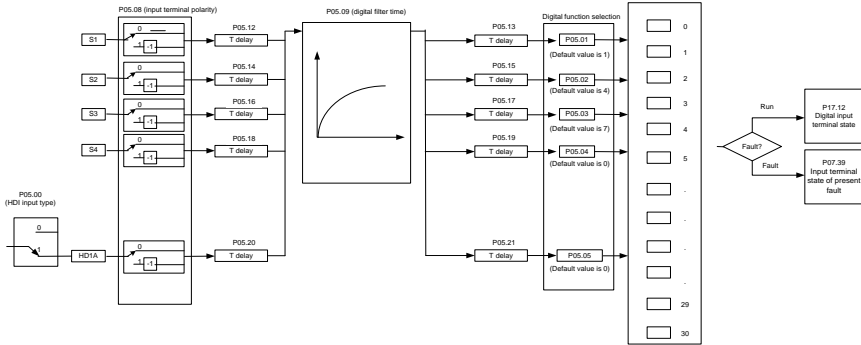

This parameter is used to set the corresponding function of digital multi-function input terminals.

Note: Two different multifunction input terminals cannot be configured with a same function.

Setting	Function	Description
0	No function	The VFD does not act even if there is signal input. Set unused terminals to "no function" to avoid misaction.
1	Run forward	External terminals are used to control the forward/reverse running of the inverter.
2	Run reversely	
3	Three-wire running control	The terminal is used to determine the three-wire running control of the VFD. For details, see the description for P05.13.
4	Jog forward	For details about frequency of jogging running and ACC/DEC time of jogging running, see the description for P08.06, P08.07, and P08.08.
5	Jog reversely	
6	Coast to stop	The inverter blocks output, and the stop process of motor is uncontrolled by the inverter. This mode is applied in the scenarios with large-inertia loads and without stop time requirements. Its definition is the same as P01.08, and it is mainly used in remote control.
7	Fault reset	External fault reset function, same as the reset function of the STOP/RS1 key on the keypad. You can use this function to reset faults remotely.
8	Pause running	The inverter decelerates to stop, however, all the run parameters are in memory state, such as PLC and PID parameters. After this signal disappears, the inverter will revert to the state before stop.
9	External fault input	When external fault signal is transmitted to the inverter, the inverter releases fault alarm and stops.
10	Increase frequency	Used to change the frequency increase/decrease command

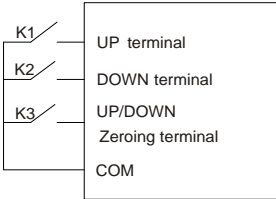
Setting	Function	Description																				
	setting (UP)	when the frequency is given by external terminals.																				
11	Decrease frequency setting (DOWN)																					
12	Clear the frequency increase/decrease setting		The terminal used to clear frequency-increase/decrease setting can clear the frequency value of auxiliary channel set by UP/DOWN , thus restoring the reference frequency to the frequency given by main reference frequency command channel.																			
13	Switch between A setting and B setting	The function is used to switch between the frequency setting channels.																				
14	Switch between combination setting and A setting	Function 13 can implement the switchover between A frequency reference channel and B frequency reference channel; function 14 can implement the switchover between the combination channel set by P00.09 and the A frequency reference channel; function 15 can implement the switchover between the combination channel set by P00.09 and the B frequency reference channel.																				
15	Switch between combination setting and B setting																					
16	Multi-step speed terminal 1	<p>A total of 16-step speeds can be set by combining digital states of these four terminals.</p> <p>Note: Multi-step speed 1 is the low-order bit, and multi-step speed 4 is the high-order bit.</p> <table border="1" data-bbox="456 970 969 1054"> <thead> <tr> <th>Multi-step speed 4</th> <th>Multi-step speed 3</th> <th>Multi-step speed 2</th> <th>Multi-step speed 1</th> </tr> </thead> <tbody> <tr> <td>Bit3</td> <td>Bit2</td> <td>Bit1</td> <td>Bit0</td> </tr> </tbody> </table>	Multi-step speed 4	Multi-step speed 3	Multi-step speed 2	Multi-step speed 1	Bit3	Bit2	Bit1	Bit0												
Multi-step speed 4	Multi-step speed 3		Multi-step speed 2	Multi-step speed 1																		
Bit3	Bit2		Bit1	Bit0																		
17	Multi-step speed terminal 2																					
18	Multi-step speed terminal 3																					
19	Multi-step speed terminal 4																					
20	Pause multi-step speed running	The multi-step speed selection function can be screened to keep the set value in the present state.																				
21	ACC/DEC time selection 1	The status of the two terminals can be combined to select four groups of ACC/DEC time.																				
22	ACC/DEC time selection 2	<table border="1" data-bbox="450 1193 976 1331"> <thead> <tr> <th>Terminal 1</th> <th>Terminal 2</th> <th>ACC/DEC time</th> <th>Parameter</th> </tr> </thead> <tbody> <tr> <td>OFF</td> <td>OFF</td> <td>ACC/DEC time 1</td> <td>P00.11/P00.12</td> </tr> <tr> <td>ON</td> <td>OFF</td> <td>ACC/DEC time 2</td> <td>P08.00/P08.01</td> </tr> <tr> <td>OFF</td> <td>ON</td> <td>ACC/DEC time 3</td> <td>P08.02/P08.03</td> </tr> <tr> <td>ON</td> <td>ON</td> <td>ACC/DEC time 4</td> <td>P08.04/P08.05</td> </tr> </tbody> </table>	Terminal 1	Terminal 2	ACC/DEC time	Parameter	OFF	OFF	ACC/DEC time 1	P00.11/P00.12	ON	OFF	ACC/DEC time 2	P08.00/P08.01	OFF	ON	ACC/DEC time 3	P08.02/P08.03	ON	ON	ACC/DEC time 4	P08.04/P08.05
Terminal 1	Terminal 2	ACC/DEC time	Parameter																			
OFF	OFF	ACC/DEC time 1	P00.11/P00.12																			
ON	OFF	ACC/DEC time 2	P08.00/P08.01																			
OFF	ON	ACC/DEC time 3	P08.02/P08.03																			
ON	ON	ACC/DEC time 4	P08.04/P08.05																			
23	Simple PLC stop reset	Used to clear the previous PLC state memory information and restart the simple PLC process.																				
24	Pause simple PLC	Used to pause the simple PLC. When the function is revoked,																				

Setting	Function	Description
		the simple PLC resumes the running.
25	Pause PID1 control	PID is ineffective temporarily, and the VFD maintains current frequency output.
26	Pause wobbling frequency	-
27	Reset wobbling frequency	-
28	Reset the counter	The counter is cleared.
29	Switch between speed control and torque control	The VFD switches from torque control mode to speed control mode, or vice versa.
30	Disable ACC/DEC	Used to ensure the VFD is not impacted by external signals (except for stop command), and maintains the present output frequency.
31	Trigger the counter	Used to enable the counter to count pulses.
33	Clear the frequency increase/decrease setting temporarily	When the terminal is closed, the frequency value set by UP/DOWN can be cleared to restore the reference frequency to the frequency given by frequency command channel; when the terminal is opened, it restores to the frequency value after frequency increase/decrease setting.
34	DC braking	The VFD starts DC brake immediately after the command becomes valid.
35	Switchover between motors 1 and 2	When the function is enabled, you can realize switchover control of two motors.
36	Switch the running command channel to keypad	When the function is enabled, the running command channel is switched to keypad. When the function is disabled, the running command channel is restored to the previous setting.
37	Switch the running command channel to terminal	When the function is enabled, the running command channel is switched to terminal. When the function is disabled, the running command channel is restored to the previous setting.
38	Switch the running command channel to communication	When the function is enabled, the running command channel is switched to communication. When the function is disabled, the running command channel is restored to the previous setting.
39	Pre-exciting command	When the function is enabled, motor pre-exciting is started until the function becomes invalid.
40	Clear power consumption quantity	After this command becomes valid, the power consumption quantity of the VFD will be zeroed out.
41	Keep power consumption quantity	When the function is enabled, the present operation of the VFD does not impact the power consumption quantity.
42	Switch the setting source of braking torque	The torque upper limit is set through the keypad when the command is valid.

Setting	Function	Description
	upper limit to keypad	
73	PID2 start	When the command is valid, PID2 starts.
74	PID2 stop	When the command is valid, PID2 stops.
75	Pause PID2 integral	When the command is valid, PID2 integral is paused.
76	Pause PID2 control	When the command is valid, PID2 control is paused.
77	Switch PID2 polarities	When the command is valid, PID2 polarity is switched.
78	HVAC disabled (only in stopped state)	When the command is valid, HVAC is disabled (only in stopped state).
79	Trigger fire signal	When the command is valid, fire signal is triggered.
80	Pause PID1 control	When the command is valid, PID1 control is paused.
81	Pause PID1 integral	When the command is valid, PID1 integral is paused.
82	Switch PID1 polarities	When the command is valid, PID1 polarity is switched.
83	Trigger sleep mode	When the command is valid, the sleep mode is triggered.
84	Trigger wakeup mode	When the command is valid, the wakeup mode is triggered.
85	Manual alternation	When the command is valid, manual alternation is enabled.
86	Pump cleaning signal	When the command is valid, pump cleaning signal is triggered.
87	Water level upper limit of inlet pool	When the command is valid, the water level upper limit of inlet pool is reached.
88	Water level lower limit of inlet pool	When the command is valid, the water level lower limit of inlet pool is reached.
89	Water shortage level of inlet pool	When the command is valid, the water shortage level of inlet pool is reached.
104	Disable motor A	When the command is valid, motor A is disabled.
105	Disable motor B	When the command is valid, motor B is disabled.
106	Disable motor C	When the command is valid, motor C is disabled.
107	Disable motor D	When the command is valid, motor D is disabled.
108	Disable motor E	When the command is valid, motor E is disabled.
109	Disable motor F	When the command is valid, motor F is disabled.
110	Disable motor G	When the command is valid, motor G is disabled.
111	Disable motor H	When the command is valid, motor H is disabled.

Related function parameters

Function code	Name	Description	Default
P05.00	HDI input type	0x00–0x11 Ones place: HDIA input type 0: HDIA is high-speed pulse input 1: HDIA is digital input Tens place: Reserved	0x00
P05.01	Function of S1	0: No function 1: Run forward	1
P05.02	Function of S2		4
P05.03	Function of S3		7

Function code	Name	Description	Default
P05.04	Function of S4	2: Run reversely	0
P05.05	Function of HDIA	3: Three-wire running control	0
P05.06	Reserved	4: Jog forward	/
P05.07	Reserved	5: Jog reversely	/
		6: Coast to stop	
		7: Fault reset	
		8: Pause running	
		9: External fault input	
		10: Increase frequency setting (UP)	
		11: Decrease frequency setting (DOWN)	
		12: Clear the frequency increase/decrease setting	
		13: Switch between A setting and B setting	
		14: Switch between combination setting and A setting	
		15: Switch between combination setting and B setting	
		16: Multi-step speed terminal 1	
		17: Multi-step speed terminal 2	
		18: Multi-step speed terminal 3	
		19: Multi-step speed terminal 4	
		20: Pause multi-step speed running	
		21: ACC/DEC time selection 1	
		22: ACC/DEC time selection 2	
		23: Simple PLC stop reset	
		24: Pause simple PLC	
		25: Pause PID1 control	
		26: Pause wobbling frequency	
		27: Reset wobbling frequency	
		28: Counter reset	
		29: Switch between speed control and torque control	
		30: Disable ACC/DEC	
		31: Trigger the counter	
		32: Reserved	
33: Clear the frequency increase/decrease setting temporarily			
34: DC braking			

Function code	Name	Description	Default
		35: Switch from motor 1 to motor 2 36: Switch the running command channel to keypad 37: Switch the running command channel to terminal 38: Switch the running command channel to communication 39: Pre-exciting command 40: Clear electricity consumption 41: Keep electricity consumption 42: Switch the setting source of braking torque upper limit to keypad 43–72: Reserved 73: PID2 start 74: PID2 stop 75: Pause PID2 integral 76: Pause PID2 control 77: Switch PID2 polarities 78: Disable HVAC (only in stopped state) 79: Trigger fire signal 80: Pause PID1 control 81: Pause PID1 integral 82: Switch PID1 polarities 83: Trigger sleep mode 84: Trigger wakeup mode 85: Manual alternation 86: Pump cleaning signal 87: Water level upper limit of inlet pool 88: Water level lower limit of inlet pool 89: Water shortage level of inlet pool 90–103: Reserved 104: Disable motor A 105: Disable motor B 106: Disable motor C 107: Disable motor D 108: Disable motor E 109: Disable motor F 110: Disable motor G	

Function code	Name	Description	Default
		111: Disable motor H	
P05.08	Input terminal polarity selection	0x00–0x3F	0x00
P05.09	Digital input filter time	0.000–1.000s	0.010s
P05.10	Virtual terminal setting	0x00–0x3F (0: disable, 1: enable) Bit0: S1 virtual terminal Bit1: S2 virtual terminal Bit2: S3 virtual terminal Bit3: S4 virtual terminal Bit 4: HDIA virtual terminal Bit5: HDIB (reserved)	0x00
P05.11	Terminal control mode	0: Two-wire control mode 1 1: Two-wire control mode 2 2: Three-wire control mode 1 3: Three-wire control mode 2	0
P05.12	S1 switch-on delay	0.000–50.000s	0.000s
P05.13	S1 switch-off delay	0.000–50.000s	0.000s
P05.14	S2 switch-on delay	0.000–50.000s	0.000s
P05.15	S2 switch-off delay	0.000–50.000s	0.000s
P05.16	S3 switch-on delay	0.000–50.000s	0.000s
P05.17	S3 switch-off delay	0.000–50.000s	0.000s
P05.18	S4 switch-on delay	0.000–50.000s	0.000s
P05.19	S4 switch-off delay	0.000–50.000s	0.000s
P05.20	HDIA switch-on delay	0.000–50.000s	0.000s
P05.21	HDIA switch-off delay	0.000–50.000s	0.000s
P07.39	Input terminal status at present fault	0x0000–0xFFFF	0x0000
P17.12	Digital input terminal state	0x0000–0xFFFF	0x0000

5.5.12 Digital output

The VFD carries two groups of relay output terminals and one open collector Y output terminal. All the digital output terminal functions can be used for programming through function code setting.

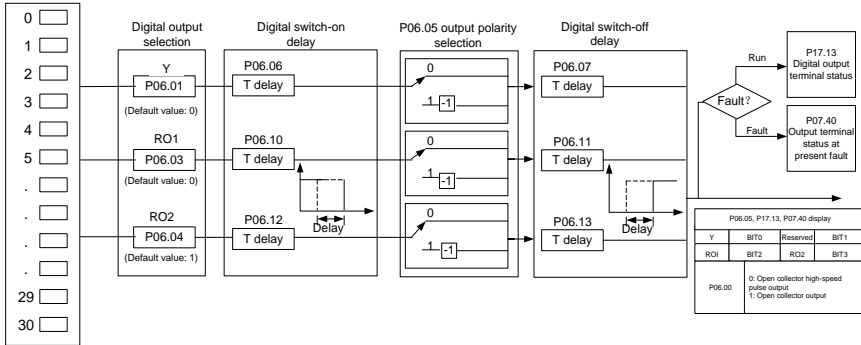

The following table lists the function code options. A same output terminal function can be repeatedly selected.

Setting	Function	Description
0	Invalid	The output terminal does not have any function.
1	Running	The ON signal is output when there is frequency output during running.
2	Running forward	The ON signal is output when there is frequency output during forward running.
3	Running reversely	The ON signal is output when there is frequency output during reverse running.
4	Jogging	The ON signal is output when there is frequency output during jogging.
5	Inverter fault	The ON signal is output when an inverter fault occurred.
6	Frequency level detection FDT1	Refer to the descriptions for P08.32 and P08.33.
7	Frequency level detection FDT2	Refer to the descriptions for P08.34 and P08.35.
8	Frequency reached	Refer to the description for P08.36.
9	Running in zero speed	The ON signal is output when the VFD output frequency and reference frequency are both zero.
10	Upper limit frequency reached	The ON signal is output when the running frequency reaches the upper limit frequency.
11	Lower limit frequency reached	Output ON signal when the running frequency reached lower limit frequency
12	Ready for running	Main circuit and control circuit powers are established, the protection functions do not act; when the VFD is ready to run, output ON signal.
13	Pre-exciting	Output ON signal during pre-exciting of the VFD

Setting	Function	Description
14	Overload pre-alarm	The ON signal is output when the pre-alarm time elapsed based on the pre-alarm threshold; for details, see descriptions for P11.08–P11.10.
15	Underload pre-alarm	The ON signal is output after the alarm time elapsed based on the alarm threshold. For details, see the descriptions for P11.11–P11.12.
16	Simple PLC stage completed	When the present state of the simple PLC is completed, it outputs a signal.
17	Simple PLC cycle completed	When a single cycle of the simple PLC is completed, it outputs a signal.
18	Set counting value reached	-
19	Designated counting value reached	-
20	External fault is valid	-
22	Running time reached	-
23	Modbus communication virtual terminal output	A signal is output based on the value set through Modbus communication. When the value is 1, the ON signal is output; when the value is 0, the OFF signal is output.
24	PROFIBUS/CANopen/BACnet MSTP communication virtual terminal output	Output corresponding signal based on the set value of PROFIBUS/CANopen/BACnet MSTP. (Output ON signal when it is set to 1, output OFF signal when it is set to 0.)
25	Ethernet communication virtual terminal output	A signal is output based on the value set through Ethernet communication. When the value is 1, the ON signal is output; when the value is 0, the OFF signal is output.
26	DC bus voltage established	When the bus voltage is above the inverter undervoltage, the output is valid.
33	In speed limit	-
34	PROFINET/EtherNet IP communication virtual terminal output	A signal is output based on the value set through PROFINET/EtherNet IP communication. (Output ON signal when it is set to 1, output OFF signal when it is set to 0.)
37	Any frequency reached	-
48	Fire mode activated	-
49	Pre-alarm of PID1 feedback too low	-
50	Pre-alarm of PID1 feedback too high	-
51	PID1 in sleep	-
52	PID2 in startup	-
53	PID2 stopped	-

Setting	Function	Description
54	Indication of run with backup pressure	-
55	Water shortage indication of inlet pool	-
56	Pre-alarm output	-
57	Control variable-frequency circulation motor A	-
58	Control variable-frequency circulation motor B	-
59	Control variable-frequency circulation motor C	-
60	Control variable-frequency circulation motor D	-
61	Control variable-frequency circulation motor E	-
62	Control variable-frequency circulation motor F	-
63	Control variable-frequency circulation motor G	-
64	Control variable-frequency circulation motor H	-
65	Low temperature pre-alarm	-
66	Stalling pre-alarm	-
67	Dry-pumping pre-alarm	-
68	PTC overtemperature pre-alarm	-

Related function parameters

Function code	Name	Description	Default
P06.01	Y1 output	0: Invalid	0
P06.02	Reserved	1: Running	-
P06.03	RO1 output	2: Running forward	1
P06.04	Reserved	3: Running reversely 4: Jogging 5: VFD in fault 6: Frequency level detection FDT1 7: Frequency level detection FDT2 8: Frequency reached 9: Running in zero speed	-

Function code	Name	Description	Default
		10: Upper limit frequency reached 11: Frequency lower limit reached 12: Ready for running 13: Pre-exciting 14: Overload pre-alarm 15: Underload pre-alarm 16: Simple PLC stage completed 17: Simple PLC cycle completed 18: Set counting value reached 19: Designated counting value reached 20: External fault is valid 21: Reserved 22: Running time reached 23: MODBUS communication virtual terminal output 24: PROFIBUS/CANopen/BACnet MSTP communication virtual terminal output 25: Ethernet communication virtual terminal output 26: DC bus voltage established 27–32: Reserved 33: In speed limit PROFINET/EtherNet IP communication virtual terminal output 35–36: Reserved 37: Any frequency reached 38–47: Reserved 48: Fire mode activated 49: Pre-alarm of PID1 feedback too low 50: Pre-alarm of PID1 feedback too high 51: PID1 in sleep 52: PID2 in startup 53: PID2 stopped 54: Indication of run with backup pressure 55: Water shortage indication of inlet pool 56: Pre-alarm output 57: Control variable-frequency circulation motor A 58: Control variable-frequency circulation motor B	

Function code	Name	Description	Default
		59: Control variable-frequency circulation motor C 60: Control variable-frequency circulation motor D 61: Control variable-frequency circulation motor E 62: Control variable-frequency circulation motor F 63: Control variable-frequency circulation motor G 64: Control variable-frequency circulation motor H 65: Low-temperature pre-alarm 66: Stalling pre-alarm 67: Dry-pumping pre-alarm 68: PTC overtemperature pre-alarm	
P06.05	Output terminal polarity	0x00–0x0F	0x00
P06.06	Y switch-on delay	0.000–50.000s	0.000s
P06.07	Y switch-off delay	0.000–50.000s	0.000s
P06.10	RO1 switch-on delay	0.000–50.000s	0.000s
P06.11	RO1 switch-off delay	0.000–50.000s	0.000s
P07.40	Output terminal status at present fault	0x0000–0xFFFF	0x0000
P17.13	Digital output terminal status	0x0000–0x000F	0x0000

5.5.13 Simple PLC

Simple PLC is a multi-step speed generator, and the VFD can change the running frequency and direction automatically based on the running time to fulfill process requirements. Previously, such function was realized with external PLC, while now, the VFD itself can achieve this function.

The VFD can realize 16-step speeds control, and provide four groups of acceleration/deceleration time for choose.

After the set PLC completes one cycle (or one step), one ON signal can be output by the multifunction relay.

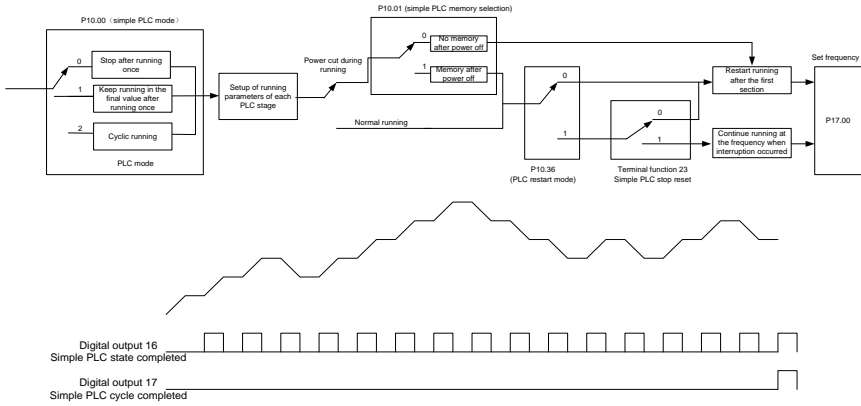

Related function parameters

Function code	Name	Description	Default
P05.01–P05.06	Digital input function selection	23: Simple PLC stop reset 24: Pause simple PLC 25: Pause PID control	0
P06.01–P06.04	Digital output function selection	16: Simple PLC stage reached 17: Simple PLC cycle reached	0
P10.00	Simple PLC mode	0: Stop after running once 1: Keep running with the final value after running once 2: Cyclic running	0
P10.01	Simple PLC memory selection	0: Do not memorize at power outage 1: Memorize at power outage	0
P10.02	Multi-step speed 0	-300.0%–300.0%	0.0%
P10.03	Running time of step 0	0.0–6553.5s (min)	0.0s
P10.04	Multi-step speed 1	-300.0%–300.0%	0.0%
P10.05	Running time of step 1	0.0–6553.5s (min)	0.0s
P10.06	Multi-step speed 2	-300.0%–300.0%	0.0%
P10.07	Running time of step 2	0.0–6553.5s (min)	0.0s
P10.08	Multi-step speed 3	-300.0%–300.0%	0.0%
P10.09	Running time of step 3	0.0–6553.5s (min)	0.0s
P10.10	Multi-step speed 4	-300.0%–300.0%	0.0%
P10.11	Running time of step 4	0.0–6553.5s (min)	0.0s
P10.12	Multi-step speed 5	-300.0%–300.0%	0.0%
P10.13	Running time of step 5	0.0–6553.5s (min)	0.0s
P10.14	Multi-step speed 6	-300.0%–300.0%	0.0%
P10.15	Running time of step 6	0.0–6553.5s (min)	0.0s

Function code	Name	Description	Default
P10.16	Multi-step speed 7	-300.0%–300.0%	0.0%
P10.17	Running time of step 7	0.0–6553.5s (min)	0.0s
P10.18	Multi-step speed 8	-300.0%–300.0%	0.0%
P10.19	Running time of step 8	0.0–6553.5s (min)	0.0s
P10.20	Multi-step speed 9	-300.0%–300.0%	0.0%
P10.21	Running time of step 9	0.0–6553.5s (min)	0.0s
P10.22	Multi-step speed 10	-300.0%–300.0%	0.0%
P10.23	Running time of step 10	0.0–6553.5s (min)	0.0s
P10.24	Multi-step speed 11	-300.0%–300.0%	0.0%
P10.25	Running time of step 11	0.0–6553.5s (min)	0.0s
P10.26	Multi-step speed 12	-300.0%–300.0%	0.0%
P10.27	Running time of step 12	0.0–6553.5s (min)	0.0s
P10.28	Multi-step speed 13	-300.0%–300.0%	0.0%
P10.29	Running time of step 13	0.0–6553.5s (min)	0.0s
P10.30	Multi-step speed 14	-300.0%–300.0%	0.0%
P10.31	Running time of step 14	0.0–6553.5s (min)	0.0s
P10.32	Multi-step speed 15	-300.0%–300.0%	0.0%
P10.33	Running time of step 15	0.0–6553.5s (min)	0.0s
P10.34	ACC/DEC time of steps 0–7 of simple PLC	0x0000–0xFFFF	0x0000
P10.35	ACC/DEC time of steps 8–15 of simple PLC	0x0000–0xFFFF	0x0000
P10.36	PLC restart mode	0: Restart from multi-step speed 0. 1: Resume from the paused step.	0
P17.00	Set frequency	0.00Hz–P00.03 (Max. output frequency)	0.00Hz
P17.27	Present step of simple PLC	Used to display the present step of the simple PLC function.	0

5.5.14 Multi-step speed running

Set the parameters used in multi-step speed running. The VFD allows you to set 16-step speeds, which are selectable by multi-step speed terminals 1–4, corresponding to multi-step speed 0 to multi-step speed 15.

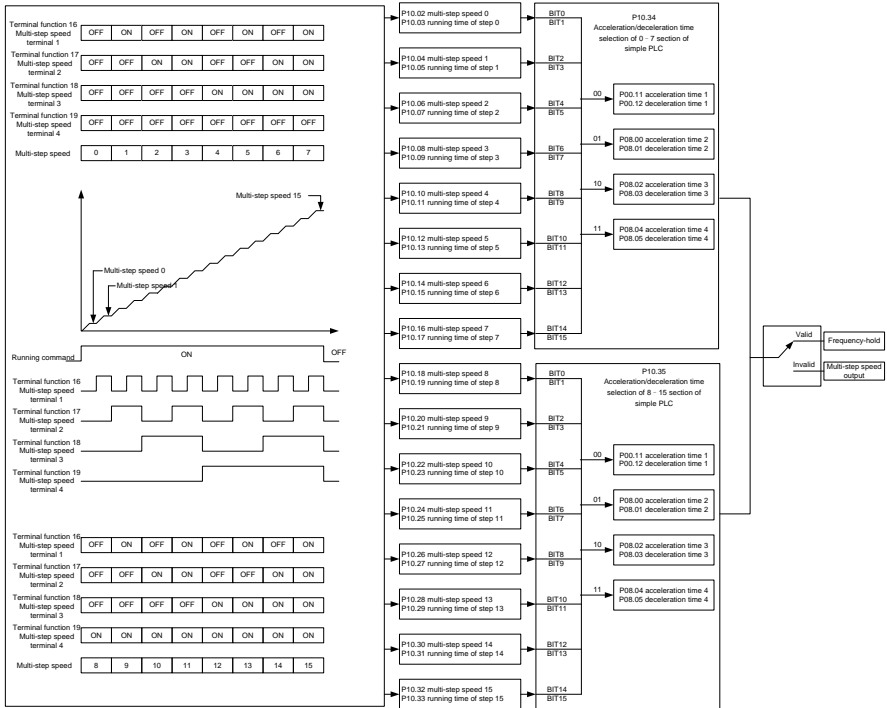

Related function parameters

Function code	Name	Description	Default
P05.01–P05.06	Digital input function selection	16: Multi-step speed terminal 1 17: Multi-step speed terminal 2 18: Multi-step speed terminal 3 19: Multi-step speed terminal 4 20: Pause multi-step speed running	0
P10.02	Multi-step speed 0	-300.0%–300.0%	0.0%
P10.03	Running time of step 0	0.0–6553.5s (min)	0.0s
P10.04	Multi-step speed 1	-300.0%–300.0%	0.0%
P10.05	Running time of step 1	0.0–6553.5s (min)	0.0s
P10.06	Multi-step speed 2	-300.0%–300.0%	0.0%
P10.07	Running time of step 2	0.0–6553.5s (min)	0.0s
P10.08	Multi-step speed 3	-300.0%–300.0%	0.0%
P10.09	Running time of step 3	0.0–6553.5s (min)	0.0s
P10.10	Multi-step speed 4	-300.0%–300.0%	0.0%
P10.11	Running time of step 4	0.0–6553.5s (min)	0.0s

Function code	Name	Description	Default
P10.12	Multi-step speed 5	-300.0%–300.0%	0.0%
P10.13	Running time of step 5	0.0–6553.5s (min)	0.0s
P10.14	Multi-step speed 6	-300.0%–300.0%	0.0%
P10.15	Running time of step 6	0.0–6553.5s (min)	0.0s
P10.16	Multi-step speed 7	-300.0%–300.0%	0.0%
P10.17	Running time of step 7	0.0–6553.5s (min)	0.0s
P10.18	Multi-step speed 8	-300.0%–300.0%	0.0%
P10.19	Running time of step 8	0.0–6553.5s (min)	0.0s
P10.20	Multi-step speed 9	-300.0%–300.0%	0.0%
P10.21	Running time of step 9	0.0–6553.5s (min)	0.0s
P10.22	Multi-step speed 10	-300.0%–300.0%	0.0%
P10.23	Running time of step 10	0.0–6553.5s (min)	0.0s
P10.24	Multi-step speed 11	-300.0%–300.0%	0.0%
P10.25	Running time of step 11	0.0–6553.5s (min)	0.0s
P10.26	Multi-step speed 12	-300.0%–300.0%	0.0%
P10.27	Running time of step 12	0.0–6553.5s (min)	0.0s
P10.28	Multi-step speed 13	-300.0%–300.0%	0.0%
P10.29	Running time of step 13	0.0–6553.5s (min)	0.0s
P10.30	Multi-step speed 14	-300.0%–300.0%	0.0%
P10.31	Running time of step 14	0.0–6553.5s (min)	0.0s
P10.32	Multi-step speed 15	-300.0%–300.0%	0.0%
P10.33	Running time of step 15	0.0–6553.5s (min)	0.0s
P10.34	ACC/DEC time of steps 0–7 of simple PLC	0x0000–0xFFFF	0x0000
P10.35	ACC/DEC time of steps 8–15 of simple PLC	0x0000–0xFFFF	0x0000
P17.27	Present step of simple PLC	Used to display the present step of the simple PLC function.	0

5.5.15 PID control

PID control, a common mode for process control, is mainly used to adjust the VFD output frequency or output voltage by performing scale-division, integral and differential operations on the difference between feedback signal of controlled variables and signal of the target, thus forming a negative feedback system to keep the controlled variables above the target. It is applicable to flow control, pressure control, temperature control, and so on. The following is the basic schematic block diagram for output frequency regulation.

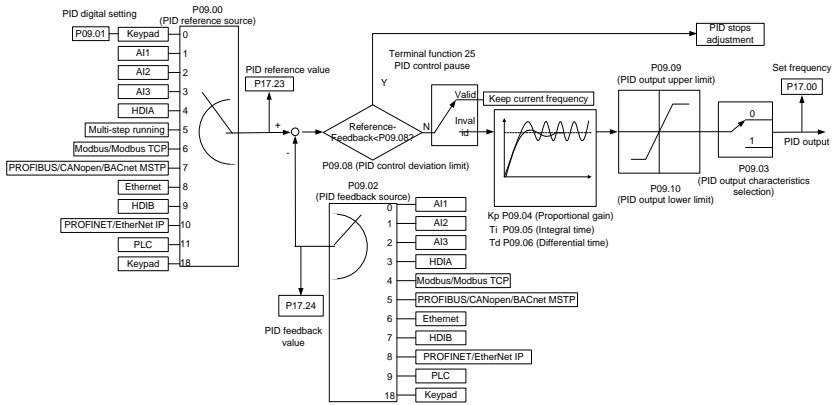

Introduction to the working principles and control methods for PID control:

Proportional control (Kp): When the feedback is different from the reference, the output will be proportional to the difference. If such a difference is constant, the regulating variable will also be constant. Proportional control can respond to feedback changes rapidly, however, it cannot eliminate the difference by itself. A larger proportional gain indicates a faster regulating speed, but a too large gain will result in oscillation. To solve this problem, set the integral time to a large value and the differential time to 0, run the system only with proportional control, and then change the reference to observe the difference (that is, static difference) between the feedback signal and reference. If the static difference occurs in the direction of reference change (such as reference increase, where the feedback is always less than the reference after system stabilizes), continue increasing the proportional gain; otherwise, decrease the proportional gain. Repeat this process until the static difference becomes small.

Integral time (Ti): When feedback is different from reference, the output regulating variable accumulates continuously, if the difference persists, the regulating variable will increase continuously until difference disappears. The integral regulator can be used to eliminate static difference. However, too large regulation may lead to repetitive overshoot, which will cause system instability and oscillation. The feature of oscillation caused by strong integral effect is that the feedback signal fluctuates up and down based on the reference variable, and fluctuation range increases gradually until oscillation occurs. The integral time parameter is generally regulated gradually from large to small until the stabilized system speed fulfills the requirement.

Differential time (Td): When the difference between feedback and reference changes, there is output of the regulating variable that is proportional to the difference variation rate, and this regulating variable is only related to the direction and magnitude of the difference change rather than the direction and magnitude of the difference itself. Differential control is used to control the feedback signal variation based on the change trend. Exercise caution before using the differential regulator since it may enlarge the system interferences, especially those with high change frequency.

When P00.06 or P00.07 (Setting channel of A/B frequency command) is 7 or P04.27 (Voltage setting channel) is 6, the VFD is process PID controlled.

5.5.15.1 General procedures for PID parameter setup

1. Determine proportional gain P.

When determining proportional gain P, first, remove the integral term and derivative term of PID by making $T_i=0$ and $T_d=0$ (see PID parameter setup for details), thus turning PID into pure proportional control. Set the input to 60%–70% of the max. allowable value, and increase proportional gain P gradually from 0 until system oscillation occurred, and then in turn, decrease proportional gain P gradually from current value until system oscillation disappears, record the proportional gain P at this point and set the proportional gain P of PID to 60%–70% of current value. This is the entire commissioning procedure of proportional gain P.

2. Determine integral time T_i .

After proportional gain P is determined, set the initial value of integral time T_i to a large value, and decrease T_i gradually until system oscillation occurs. Then in reverse, increase T_i until system oscillation disappears. Record the value of T_i at this point. Set the integral time constant T_i of PID to 150%–180% of this value. This is the commissioning procedure of integral time constant T_i .

3. Determine derivative time T_d .

The differential time T_d is generally set to 0. If you need to set T_d to another value, the setting method is similar to that for P and T_i , namely, set T_d to 30% of the value when there is no oscillation.

4. Empty system load, perform load-carrying joint debugging, and then adjust PID parameters until fulfilling the requirement.

5.5.15.2 How to fine-tune PID

After setting the parameters controlled by PID, you can adjust these parameters by the following means.

Control overshoot: When overshoot occurred, shorten the derivative time (T_d) and prolong integral time (T_i).

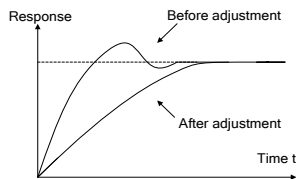

Stabilize the feedback value as fast as possible: When overshoot occurred, shorten integral time (T_i) and prolong derivative time (T_d) to stabilize control as fast as possible.

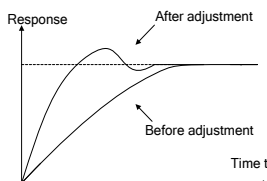

Control long-term vibration: If the cycle of periodic vibration is longer than the set value of integral time (Ti), it indicates the integral action is too strong, prolong the integral time (Ti) to control vibration.

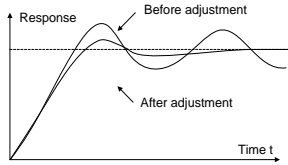

Control short-term vibration: If the vibration cycle is as short almost the same as the set value of differential time (Td), it indicates the differential action is too strong. Shorten the differential time (Td) to control vibration. When the differential time (Td) is set to 0.00 (namely no differential control), and there is no way to control vibration, decrease the proportional gain.

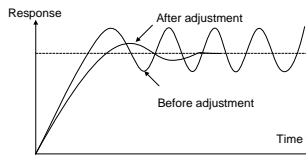

Related function parameters

Function code	Name	Description	Default
P09.00	PID reference source	0: Keypad (P09.01) 1: AI1 2: AI2 3: AI3 4: High-speed pulse HDIA 5: Multi-step running 6: Modbus/Modbus TCP communication 7: PROFIBUS/CANopen /BACnet MSTP communication 8: Ethernet communication 9: High-speed pulse HDIB 10: PROFINET/EtherNet IP communication 11: Programmable card 12-17: Reserved 18: Keypad analog	0
P09.01	PID digital setting	-100.0%~100.0%	0.0%
P09.02	PID feedback source	0: AI1 1: AI2 2: AI3 3: High-speed pulse HDIA 4: Modbus/Modbus TCP communication	0

Function code	Name	Description	Default
		5: PROFIBUS/CANopen /BACnet MSTP communication 6: Ethernet communication 7: High-speed pulse HDIB 8: PROFINET/EtherNet IP communication 9: Programmable card 10–17: Reserved 18: Keypad analog	
P09.03	PID output characteristics selection	0: PID output is positive. 1: PID output is negative.	0
P09.04	Proportional gain (Kp)	0.00–100.00	1.80
P09.05	Integral time (Ti)	0.01–10.00s	0.90s
P09.06	Differential time (Td)	0.00–10.00s	0.00s
P09.07	Sampling cycle (T)	0.000–10.000s	0.100s
P09.08	PID control deviation limit	0.0–100.0%	0.0%
P09.09	PID output upper limit	P09.10–100.0% (of max. frequency or voltage)	100.0%
P09.10	PID output lower limit	-100.0%–P09.09 (of max. frequency or voltage)	0.0%
P09.11	Feedback offline detection value	0.0–100.0%	0.0%
P09.12	Feedback offline detection time	0.0–3600.0s	1.0s
P09.13	PID control selection	0x0000–0x1111 Ones place: 0: Continue integral control after the frequency reaches upper/lower limit 1: Stop integral control after the frequency reaches upper/lower limit Tens place: 0: Same as the main reference direction 1: Contrary to the main reference direction Hundreds place: 0: Limit as per the max. frequency 1: Limit as per A frequency Thousands place: 0: A+B frequency. Acceleration /deceleration of main reference A frequency source buffering is invalid.	0x0001

Function code	Name	Description	Default
		1: A+B frequency. ACC/DEC of main reference A frequency source precharging is valid. Note: The ACC/DEC time corresponding to the thousands place is determined by ACC time 4 of P08.04.	
P09.14	Low frequency proportional gain (Kp)	0.00–100.00	1.00
P09.15	ACC/DEC time of PID command	0.0–1000.0s	0.0s
P09.16	PID output filter time	0.000–10.000s	0.000s
P09.18	Low frequency integral time (Ti)	0.00–10.00s	0.90s
P09.19	Low frequency differential time (Td)	0.00–10.00s	0.00s
P09.20	Low frequency point for PID parameter switching	0.00–P09.21	5.00Hz
P09.21	High frequency point for PID parameter switching	P09.20–P00.04	10.00Hz
P17.00	Set frequency	0.00Hz–P00.03 (Max. output frequency)	0.00Hz
P17.23	PID1 reference value	-100.0%–100.0%	0.0%
P17.24	PID1 feedback value	-100.0%–100.0%	0.0%

5.5.16 Water pump control

The VFD provides the multi-pump control function, applicable to the scenario with the simultaneous operation of up to eight water pumps, capable of balancing fluctuations in water pressure and flow. This function simplifies the control system and controls the start and stop of each pump motor in balance mode to ensure optimal performance of the water system. To use this function, configure the following sub-functions based on requirements:

- ✧ Motor adding or reducing
- ✧ Multi-pump alternation
- ✧ Water pump maintenance
- ✧ Smooth switchover

Function description

The following describes the function by illustrating a typical case in which one VFD controls four water pump motors.

The VFD must use the four relay function terminals RO5–RO8 (requiring the use of the optional part EC-IO503-00), and also use two groups of contactor KM to switch between the two water pump

working states, variable-frequency run mode and power-frequency run mode. All motors are started and stopped at the ramp speed to achieve soft motor switchover to ensure stable water supply pressure and reduce the impact on water pipes. You need to refer to Figure 5-28 and Figure 5-29 to connect the multi-pump variable-frequency control main circuit and external relay control circuit. In addition, make the following settings:

1. Enable the multi-pump control function (P94.00=1).
2. Set the variable-frequency motor run mode to circular (P94.10=1).
3. Set the motor quantity to 4 (P94.11=4).
4. Set RO5–RO8 to control variable-frequency circulation pumps A, B, C, and D (that is, set P26.06–P26.09 to 57–60 respectively).
5. Set the contactor closing delay, which is the interval of switchover between the variable-frequency run mode and power-frequency run mode.
6. Set the S digital input terminal functions to 104–107 to cut out circulation motors M1–M4.

Note:

- ✧ After the multi-pump control function is enabled, the VFD setting frequency can be given only by the water supply dedicated PID—PID1.
- ✧ It is not recommended to use the multi-pump control function on the 30kW or higher VFDs.
- ✧ Connected water pump motors must have the same rated power.

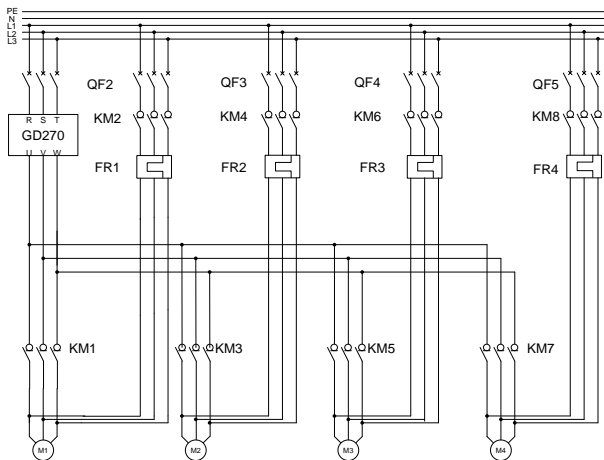

KM1–KM8: Contactors FR1–FR4: Thermal protection overload relays
 QF2–QF5: Low-voltage circuit breaker M1–M4: Asynchronous motor

Figure 5-28 Main circuit wiring in variable-frequency control mode of one VFD driving four pumps

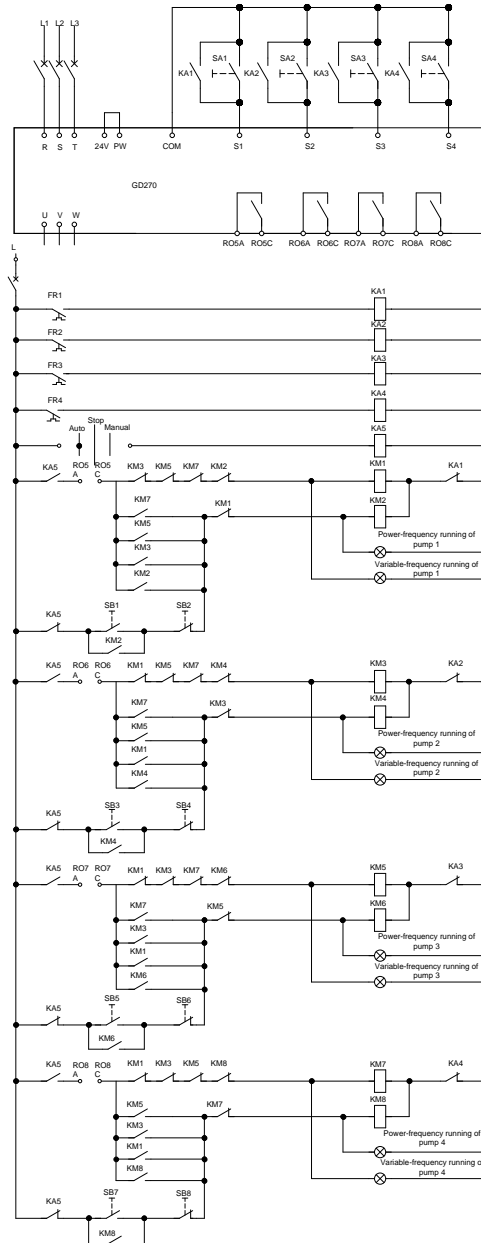

Figure 5-29 External relay control wiring (with four pumps)

If you use one VFD to control three water pump motors for variable-frequency circulation, refer to Figure 5-30 to connect the external relay control circuit.

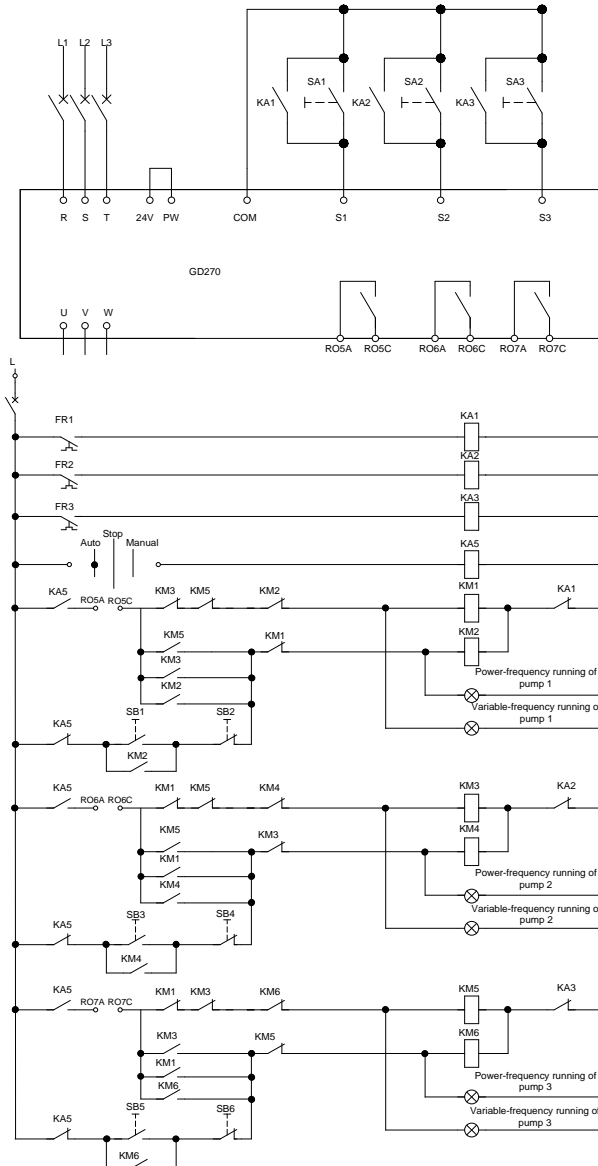

Figure 5-30 External relay control wiring (with three pumps)

If you use one VFD to control two water pump motors for variable-frequency circulation, refer to Figure 5-31 to connect the external relay control circuit.

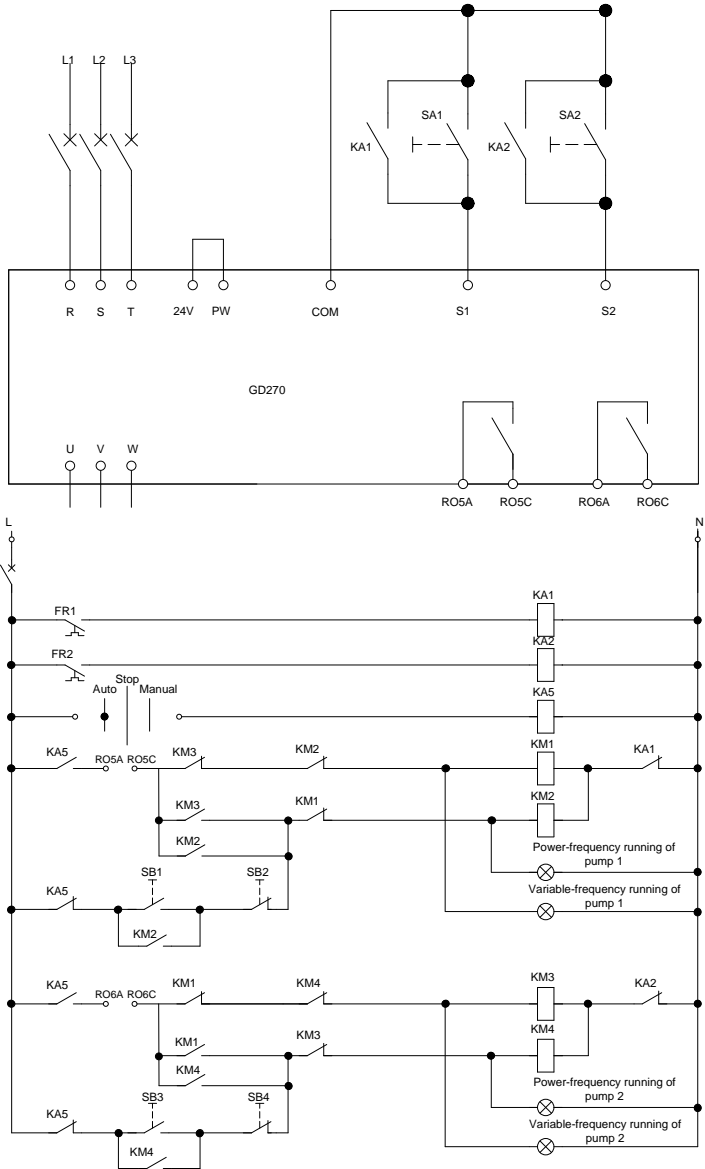

Figure 5-31 External relay control wiring (with two pumps)

Related function parameters

Function code	Name	Description	Setting
P94.00	Multi-pump and fan control function enabling	0: Invalid 1: Valid	1
P94.10	Variable-frequency motor run mode	0: Fixed 1: Circular	1
P94.11	Number of motors	0–8: corresponding to motors A–H. The sequence numbers must be successive.	4
P26.06	RO5 output	0–47: Same as those for standard models	57
P26.07	RO6 output	48: Fire mode activated	58
P26.08	RO7 output	49: Pre-alarm of PID1 feedback too low	59
P26.09	RO8 output	50: Pre-alarm of PID1 feedback too high 51: PID1 in sleep 52: PID2 in startup 53: PID2 stopped 54: Indication of run with backup pressure 55: Water shortage indication of inlet pool 56: Pre-alarm output 57: Control variable-frequency circulation pump A 58: Control variable-frequency circulation pump B 59: Control variable-frequency circulation pump C 60: Control variable-frequency circulation pump D 61: Control variable-frequency circulation motor E 62: Control variable-frequency circulation motor F 63: Control variable-frequency circulation motor G 64: Control variable-frequency circulation motor H 65: Low-temperature pre-alarm 66: Stalling pre-alarm 67: Dry-pumping pre-alarm 68: PTC overtemperature pre-alarm	60
P94.36	Contacting closing delay	0.0–100.0s	0.5s
P94.37	Contacting opening delay	0.0–100.0s	0.5s

5.5.16.1 Motor adding or reducing

Motor adding

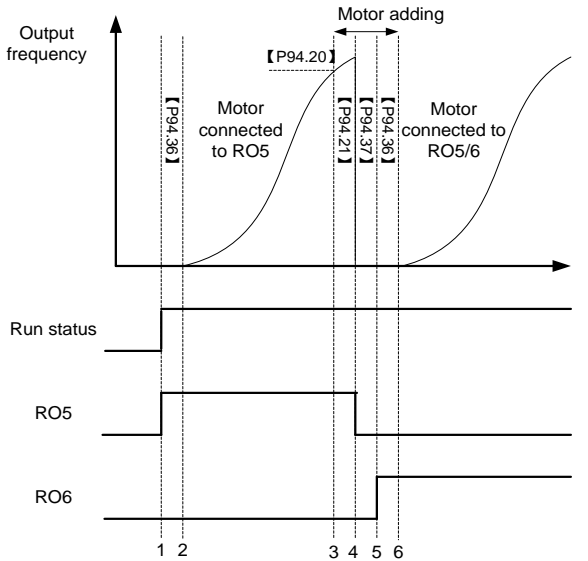

Figure 5-32 Motor adding timing

This figure assumes that the VFD outputs and controls motor M1 and the other motors are in the stopped state. At this time, if the output frequency is equal to or higher than P94.20 (Running frequency for motor adding), PID1 feedback is less than the difference between PID1 reference and P94.19 (Pressure tolerance for motor adding), and this condition lasts a period of time longer than P94.21 (Motor adding delay), the motor adding function is triggered.

If this condition lasts a period of time longer than P94.21 (Motor adding delay), motors are added, and then the VFD coasts to stop and disconnects the contactor with a contactor opening delay (P94.37) to ensure completed disconnection. The VFD closes the relay with a contactor closing delay (P94.36) to ensure completed closing.

The following table lists the relay action logic in the motor adding process.

Table 5-3 Motor adding logic in circular variable-frequency motor run mode

RO5	RO6	RO7	RO8	Motor M1	Motor M2	Motor M3	Motor M4
0	0	0	0	Stop	Stop	Stop	Stop
1	0	0	0	Variable frequency	Stop	Stop	Stop
0	0	0	0	Stop	Stop	Stop	Stop
0	1	0	0	Stop	Variable	Stop	Stop

RO5	RO6	RO7	RO8	Motor M1	Motor M2	Motor M3	Motor M4
					frequency		
1	1	0	0	Power frequency	Variable frequency	Stop	Stop
1	0	0	0	Power frequency	Stop	Stop	Stop
1	0	1	0	Power frequency	Stop	Variable frequency	Stop
1	1	1	0	Power frequency	Power frequency	Variable frequency	Stop
1	1	0	0	Power frequency	Power frequency	Stop	Stop
1	1	0	1	Power frequency	Power frequency	Stop	Variable frequency
1	1	1	1	Power frequency	Power frequency	Power frequency	Variable frequency

Motor reducing

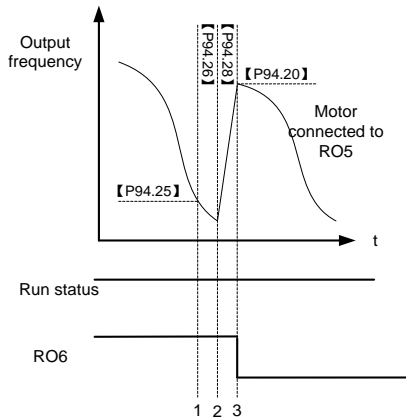

Figure 5-33 Motor reducing timing

This figure assumes that the VFD outputs and controls motor M2, M1 is in power-frequency run mode, and M3–M4 are in the stopped state. At this time, if the VFD output frequency is equal to or lower than P94.25 (Running frequency for motor reducing), PID1 feedback is less than the difference between PID1 reference and P94.24 (Pressure tolerance for motor reducing), and this condition lasts a period of time longer than P94.26 (Motor reducing delay), the motor reducing function is triggered. There are two motor reducing actions for selection, which can be set by P94.27 (Variable-frequency motor action for motor reducing).

If P94.27 (Variable-frequency motor action for motor reducing) is set to 1, the VFD not only disconnects the relay but also increases the output frequency to P94.20 (Running frequency for motor adding) within the time specified by P94.28 (Variable-frequency motor ACC time for motor reducing). When the ACC is completed or P94.27 (Variable-frequency motor action for motor reducing) is set to 0 (Keep the frequency unchanged), the VFD disconnects the relay corresponding to the power-frequency motor.

The following table lists the relay action logic in the motor reducing process.

Table 5-4 Motor reducing logic in circular variable-frequency run mode

RO5	RO6	RO7	RO8	Motor M1	Motor M2	Motor M3	Motor M4
1	1	1	1	Power frequency	Power frequency	Variable frequency	Variable frequency
0	1	1	1	Stop	Power frequency	Power frequency	Variable frequency
0	0	1	1	Stop	Stop	Power frequency	Variable frequency
0	0	0	1	Stop	Stop	Stop	Variable frequency
0	0	0	0	Stop	Stop	Stop	Stop

Related function parameters

Function code	Name	Description	Default
P94.19	Pressure tolerance for motor adding	0.0–30.0% (relative to PID1 max. value)	5.0%
P94.20	Running frequency for motor adding	P94.25 (Running frequency for motor reducing)–P00.03	50.00Hz
P94.21	Motor adding delay	0.0–3600.0s	10.0s
P94.22	Switching frequency for variable-frequency motor adding	P00.05 (Lower limit of running frequency)–P00.03	50.00Hz
P94.23	Variable-frequency motor DEC time for power-frequency motor adding	0.0–300.0s	10.0s
P94.24	Pressure tolerance for motor reducing	0.0–30.0% (relative to PID1 max. value)	4.0%
P94.25	Running frequency for motor reducing	P00.05–P94.20 (Running frequency for motor adding)	5.00Hz
P94.26	Motor reducing delay	0.0–3600.0s	10.0s

Function code	Name	Description	Default
P94.27	Variable-frequency motor action for motor reducing	0: Keep the frequency unchanged 1: Accelerate to the motor running frequency	1
P94.28	Variable-frequency motor ACC time for motor reducing	0.0–300.0s	10.0s

5.5.16.2 Alternation function

Automatic alternation

The VFD supports the automatic water pump alternation function to achieve two goals: First, to keep the run time of each pump the same to balance the loss; Second, to prevent any pump from stopping for too long, which could lead to blocking. Automatic switching can also be triggered by a timer function, i.e., the auxiliary pump is switched on at a set time.

When the initial motor running time exceeds P94.34 (Variable-frequency motor alternation cycle) (P94.34 \neq 0) and the present frequency is less than or equal to P94.35 (Alternation running frequency threshold), and there is an idle pump in the current system, the VFD starts automatic alternation in the way of adding a motor first and then reducing a motor. Then the second-run motor becomes the first-run motor, and the alternation time is calculated again. During normal use, the alternation time is also recalculated for motor reducing.

Note: Alternation time recalculation is also triggered by motor adding or reducing that occurs during normal PID adjustment.

Related function parameters

Function code	Name	Description	Default
P94.34	Variable-frequency motor cycling period	0.0–6000.0h Automatic alternation is targeted at idle variable-frequency motors. The value 0 indicates no alternation.	0.0h
P94.35	Alternation frequency threshold	P00.05–P00.03 When the running frequency is greater than the value of this function code, variable-frequency motor alternation is not performed. Otherwise, great water pressure change impacts water supply.	45.00Hz

Manual alternation

Manual alternation is used for testing to check whether the main circuit wiring and control circuit wiring are correct and motors can run properly. If alternation is completed or terminated, a stop command must be given so that the next alternation mode can be entered after restart.

The function is implemented as follows: When the VFD is in stopped stated, set the terminal input function to 85 (Manual alternation), enable the terminal function, and then send a startup command. The VFD starts all connected motors from motor M1 in alternation mode. During alternation, all motors are started by means of adding motors in sequence. When all motors have been started, motors are automatically reduced in sequence until the end.

Note: During alternation, if the enabling signal of an S terminal is canceled, the alternation persists until the end. If you want to terminate the alternation, you need to trigger a stop signal.

5.5.16.3 Water pump maintenance

You can set the S digital input terminal functions to 104–107 to lock motors M1–M4, which will not be under multi-pump control. You only need to disconnect the motor wiring contactors from the grid to maintain the pumps, without adjusting the onsite wiring.

5.5.16.4 Smooth switchover

When a motor switches from the variable-frequency run mode to the power-frequency run mode, the water pressure fluctuates greatly. You can set P94.22 (Switching frequency for variable-frequency motor adding) to enable the motor runs from a high switching frequency to the power-frequency run mode, preventing the water pressure from dropping too quick so as to ensure water pressure steady.

Related function parameters

Function code	Name	Description	Default	Modify
P94.22	Switching frequency for variable-frequency motor adding	P00.05 (Lower limit of running frequency)–P00.03	50.00Hz	<input type="radio"/>

5.5.16.5 Fixed variable-frequency run mode

The fixed variable-frequency control logic is relatively simple. The following assumes one VFD drives four motors in fixed variable-frequency run mode. Se the following parameters.

1. Enable the multi-pump control function (P94.00=1).
2. Set the variable-frequency motor run mode to fixed (P94.10=0).
3. Set the motor quantity to 4 (P94.11=4).
4. Set RO5–RO8 to control motors A, B, C, and D respectively (set P26.06–P26.09 to 57–60 respectively).
5. Set the contactor closing delay, which is the interval of switchover between the variable-frequency run mode and power-frequency run mode.

The following figures and tables show the control logic.

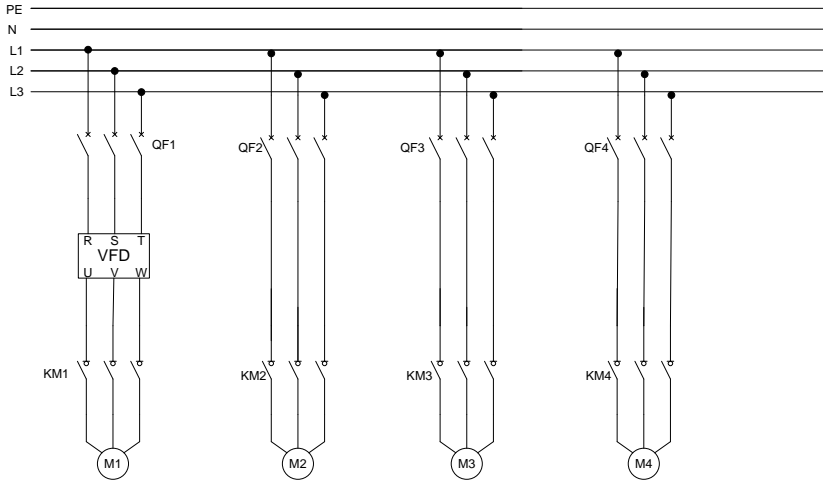

KM1–KM4: Contactors

QF1–QF4: Low-voltage breakers

M1–M4:

Asynchronous motors

Figure 5-34 Main circuit wiring in fixed variable-frequency run mode

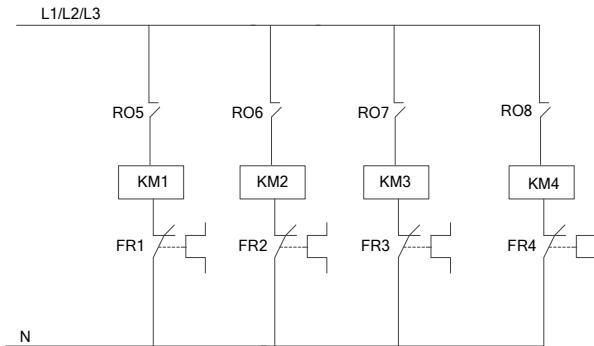

Figure 5-35 Control circuit wiring in fixed variable-frequency run mode

Table 5-5 Motor adding logic in fixed variable-frequency run mode

RO5	RO6	RO7	RO8	Motor 1	Motor 2	Motor 3	Motor 4
0	0	0	0	Stop	Stop	Stop	Stop
1	0	0	0	Variable frequency	Stop	Stop	Stop
1	1	0	0	Variable frequency	Power frequency	Stop	Stop
1	1	1	0	Variable	Power frequency	Power	Stop

RO5	RO6	RO7	RO8	Motor 1	Motor 2	Motor 3	Motor 4
				frequency		frequency	
1	1	1	1	Variable frequency	Power frequency	Power frequency	Power frequency

Table 5-6 Motor reducing logic with fixed variable-frequency motors

RO5	RO6	RO7	RO8	Motor 1	Motor 2	Motor 3	Motor 4
1	1	1	1	Variable frequency	Power frequency	Power frequency	Power frequency
1	0	1	1	Variable frequency	Stop	Power frequency	Power frequency
1	0	0	1	Variable frequency	Stop	Stop	Power frequency
1	0	0	0	Variable frequency	Stop	Stop	Stop
0	0	0	0	Stop	Stop	Stop	Stop

5.5.17 PID function only for water supply

The VFD provides two groups of PID only for water supply, only by which HVAC related PID setting can be implemented. The following takes PID1 as an example to describe the function.

The unit of PID1 reference and PID1 feedback can be specified by P90.00. PID source 1 (P90.06 and P90.08, that is, PID reference and feedback) can be set for PID1, and PID source 2 (P90.11 and P90.13, that is, PID reference and feedback) can be set for PID2. P90.16 is the combination method of PID source1 and source 2.

PID1 reference and PID1 feedback can be set to the actual water pressure values but not a percentage. P90.01 can specify the number of decimal places of PID1 reference and PID1 feedback. P90.02 can specify the actual water pressure corresponding to 100% of PID1 reference. P90.03 and P90.04 can specify the upper limit and lower limit of PID1 reference. In most cases, P90.02 and P90.03 are set to the same value. P89.09 and P89.10 can be used to view the percentage of PID1 reference and PID1 feedback.

Note: PID2 differs from PID1: PID2 cannot participate in the running frequency regulation. You can only convert PID2 output to analog signal by setting the AO function (setting 32).

For the related function codes, see Group P90—PID1 control and Group P91—PID2 control.

5.5.18 Segmented wind and water pressure function (used with LCD keypad)

If you have purchased the optional LCD keypad, you can install batteries into the keypad to enable the clock function. Then you can set working days through P92.04 and set start time and stop time of working days through P92.05–P92.08. P95 can specify water pressure by time segment. P92.06 is set to 0. Within a specific time segment, P90.07 (PID1 reference value 1 through keypad) will be

overwritten by the multi-segment water pressure setpoint.

Related function parameters

Function code	Name	Description	Default	Modify
P95.00	Actual time	00.00–23.59 Set the clock date and time in group P92.	00.00	●
P95.01	Number of pressure segments	0–8 (0 indicates that this function is disabled.)	0	○
P95.02	Start time of T1	After the Tx moment, the water pressure will become the pressure of the Tx period. The water pressure before T1 is set to 0. Please note to set the end period. The segment selection in P95.01 indicates the number of valid segments. Settings beyond the selected segments will be invalid. If the start time of Tx is later than the start time of T(x+1), T(x+1) automatically changes to Tx. Start time range of Tx: 00.00–23.59 Pressure range of Tx period: 0.0–100.0%	00.00	○
P95.03	Pressure at T1		0.0%	○
P95.04	Start time of T2		23.00	○
P95.05	Pressure at T2		0.0%	○
P95.06	Start time of T3		23.00	○
P95.07	Pressure at T3		0.0%	○
P95.08	Start time of T4		23.00	○
P95.09	Pressure at T4		0.0%	○
P95.10	Start time of T5		23.00	○
P95.11	Pressure at T5		0.0%	○
P95.12	Start time of T6		23.00	○
P95.13	Pressure at T6		0.0%	○
P95.14	Start time of T7		23.00	○
P95.15	Pressure at T7		0.0%	○
P95.16	Start time of T8		23.59	○
P95.17	Pressure at T8		0.0%	○

5.5.19 Automatic sleep

Function code P94.01 specifies the sleep method. When the condition specified by P94.02 or P94.03 and the condition lasts the time specified by P94.04, the PID increases by P94.05 (PID boost value for sleep) with a duration specified by P94.06 (PID boost time), and the VFD enters the sleep state. When P94.08 (Wakeup condition) is met and this condition lasts the time specified by P94.09 (Wakeup time), the VFD automatically wakes up from sleep and directly runs at the frequency specified by P94.07, and the frequency is PID regulated later.

Related function parameters

Function code	Name	Description	Default	Modify
P94.00	Multi-pump and fan control function enabling	0: Invalid 1: Valid	0	◎
P94.01	Sleep method	0: Sleep according to terminal input	0	○

Function code	Name	Description	Default	Modify
	selection	1:Sleep according to run frequency 2:Sleep according to deviation		
P94.02	Sleep start frequency	P00.05–P00.04 (Upper limit of running frequency) Sleep mode is only allowed when the running frequency is less than or equal to the sleep start frequency and the duration exceeds P94.04.	5.00Hz	<input type="radio"/>
P94.03	Sleep starting deviation	0.0–30.0% (relative to PID1 max. value) When output is positive, if the feedback is greater than the reference, sleep is allowed only when the absolute difference is greater than the sleep starting deviation and the situation lasts the time longer than P94.04. When output is negative, if the feedback is less than the reference, sleep is allowed only when the absolute difference is greater than the sleep starting deviation and the situation lasts the time longer than P94.04.	5.0%	<input type="radio"/>
P94.04	Sleep delay	P94.49–3600.0s	60.0s	<input type="radio"/>
P94.05	PID1 reference boost value	-100.0–100.0% (relative to PID1 reference value)	10.0%	<input type="radio"/>
P94.06	Longest boost time	0.000–6000.0s This function is used for continuous VFD running when the running frequency reaches the upper limit frequency but the feedback value cannot reach the setting after boost. In this situation, the VFD enters the sleep mode at once after the boost time.	10.0s	<input type="radio"/>
P94.07	Sleep wakeup frequency	P00.05–P00.04 (Upper limit of running frequency) In closed-loop PID, the PID output is superimposed directly from the corresponding value of this frequency when the VFD is woken up.	5.00Hz	<input type="radio"/>
P94.08	Wake-up-from-sleep deviation	0.0–30.0% (relative to PID1 max. value) In closed-loop PID, when output is positive, if the feedback is less than the reference, wakeup is allowed only when the actual	5.0%	<input type="radio"/>

Function code	Name	Description	Default	Modify
		difference is greater than the wake-up-from-sleep deviation and this situation lasts the time longer than P94.09. When the output characteristic is negative, wake-up is only allowed when the feedback is greater than the reference, the absolute value of the actual deviation exceeds the wake-up-from-sleep deviation, and the duration exceeds P94.09.		
P94.09	Wake-up-from-sleep delay	P94.49–3600.0s Min. sleep time	40.0s	<input type="radio"/>

5.5.20 Water level control

The VFD receives the inlet water level signal in real time. If the water level of the inlet pool changes from high to low, then when the water level value is above the lower limit water level, the PID1 reference value is the normal set value; when the water level value is below the lower limit water level and above the water shortage level, the PID1 reference value is the backup reference value P94.43; when the water level value is below the water shortage level, then the control system will shut down all water pumps. If the water level of the inlet pool changes from low to high, then when the water level is below the lower water level limit, the system will stop; when the water level is below the upper water level limit and above the lower water level limit, the PID1 reference value is the backup reference value P94.43; when the water level is above the upper water level limit, the PID1 reference value is the normal set value.

Function code	Name	Description	Default	Modify
P94.39	Water level signal input selection of inlet pool	0: None 1: Digital 2: AI1 3: AI2 4: AI3 5: HDIA 6: Reserved 7: Communication card	0	<input type="radio"/>
P94.40	Water level upper limit of inlet pool	0.0–100.0%	60.0%	<input type="radio"/>
P94.41	Water level lower limit of inlet pool	0.0%–P94.40	40.0%	<input type="radio"/>
P94.42	Water shortage	0.0%–P94.41	20.0%	<input type="radio"/>

Function code	Name	Description	Default	Modify
	level of inlet pool			
P94.43	Backup pressure upon exceptions	0.0–100.0% (relative to PID1 max. value)	0.0%	<input type="radio"/>
P94.44	Protection value for PID1 feedback too low	0.0–100.0% (relative to PID1 max. value)	10.0%	<input type="radio"/>
P94.45	Delay of PID1 feedback too low	0.0–3600.0s Corresponding terminal output that is set when PID1 feedback value is less than P94.44 and this situation lasts the time longer than P94.45.	500.0s	<input type="radio"/>
P94.46	Protection value for PID1 feedback too high	0.0–100.0% (relative to PID1 max. value)	80.0%	<input type="radio"/>
P94.47	Delay of PID1 feedback too high	0.0–3600.0s Corresponding terminal output that is set when PID1 feedback value is greater than P94.46 and this situation lasts the time longer than P94.47.	500.0s	<input type="radio"/>

5.5.21 Pump cleaning

The VFD supports water pump cleaning, which is shown in Figure 5-36. The motor runs forward for certain time, it runs reversely for certain time after a period of stop, and then it runs forward after a period of stop. The motor repeats the procedure circularly.

Similar to manual alternation, the pump cleaning function can be triggered only when the VFD is in stopped state. To enable the pump cleaning function, set the terminal function to 86, enable the terminal, and send a startup signal.

After the pump cleaning function is enabled, all water pumps are cleared in order. Then the VFD automatically stops. During pump cleaning, you can terminate the pump cleaning by sending a stop command. If you want to restart pump cleaning after pump cleaning is completed or terminated, you need to send a stop command.

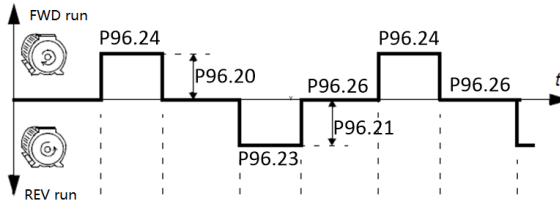

Figure 5-36 Pump cleaning logic

Related function parameters

Function code	Name	Description	Default	Modify
P96.20	Forward run frequency for pump cleaning	0.00Hz–P00.04	50.00Hz	☉
P96.21	Reverse run frequency for pump cleaning	0.00Hz–P00.04	50.00Hz	☉
P96.22	Forward run ACC time for pump cleaning	0–3600.0s	5.0s	○
P96.23	Reverse run ACC time for pump cleaning	0–3600.0s	5.0s	○
P96.24	Forward run duration for pump cleaning	0–3600.0s	5.0s	○
P96.25	Reverse run duration for pump cleaning	0–3600.0s	5.0s	○
P96.26	Forward/reverse run interval for pump cleaning	0–3600.0s	5.0s	○
P96.27	Number of pump cleaning cycles	1–1000	1	☉

5.5.22 Water pipe break detection control

Water pipe break detection control function can detect water pipe break and stop pump motors in time to reduce the loss.

This function is implemented as follows:

You can set P96.00 to 1 to enable this function. If water pipe break occurs and the water pressure cannot reach the setting, the VFD running frequency boosts up to the upper limit or the PID output

upper limit frequency. You can determine the situation by setting P96.01. When the condition reaches the time specified by P96.02, the VFD stops the motor.

Related function parameters

Function code	Name	Description	Default	Modify
P96.00	Action upon water pipe break	0: Disable 1: Report a fault	0	<input type="radio"/>
P96.01	Detection level of water pipe break	After water pipe break, the VFD running frequency boosts up to the upper limit or the PID output upper limit frequency. When it is set to 0, the water pipe break detection function is invalid. Range: 0.0–100.0%	10.0%	<input type="radio"/>
P96.02	Detection time of water pipe break	Used to check the detection time of water pipe break. Range: 0.0–6000.0s	120.0s	<input type="radio"/>

5.5.23 Water pipe soft padding

In a water supply system, the rapid influx of water into the empty water pipe can cause a water hammer effect, which damages the water pipe or valve. After water pipe soft padding is enabled, the VFD implements water injection into the water pipe slowly and steadily for every startup, avoiding the water hammer effect. If the VFD stops due to a fault during water injection, the VFD still runs the function setting after restart. This function is implemented as follows: Set P96.03 to 1 to enable soft padding. After the VFD is started, the VFD exits from the soft padding process when the motor reaches any of the two conditions, and the PID takes over the frequency control:

Condition 1: The VFD runs at the frequency specified by P96.04, and the run time reaches the time specified by P96.05.

Condition 2: The PID feedback value reaches the value specified by P96.06 (Soft padding cutoff detection level).

Related function parameters

Function code	Name	Description	Default	Modify
P96.03	Water pipe soft padding function	0: Disable 1: Enable	0	<input type="radio"/>
P96.04	Reference frequency for soft padding	0.00Hz–P00.03	30.00Hz	<input type="radio"/>
P96.05	Duration of reference frequency for soft padding	0.0–6000.0s	10.0s	<input type="radio"/>

Function code	Name	Description	Default	Modify
P96.06	Soft padding cutoff detection level	The PID function is valid when the feedback value is greater than the value of this function code. Range: 0.0–100.0%	10.0%	<input type="radio"/>

5.5.24 Freezing protection

At low temperature, water freezing in the water tube damages the water pump. After protection against freezing is enabled, the motor automatically rotates to prevent against water freezing when the ambient temperature reaches a specified value.

The VFD provides the AI/AO temperature measuring function, which supports PT100, PT1000, and KTY84 sensors. During use, select current output for AO, connect one end of the temperature resistor to AI1 and AO1 and the other end to GND. P89.23 will display the measured temperature. If the full range is exceeded, the temperature is displayed as 0°C. When P96.10 (Enabling freezing protection) is activated, if P89.32 (Measured temperature) is lower than P96.12 (Freezing protection threshold), the freezing protection signal will be activated. The VFD runs at P96.14 (Freezing protection frequency). This signal is ignored if the VFD is running. If a run command is received after the freezing protection has been activated, the protection is terminated and the run command is executed. If a stop command is received after the protection has been activated, the motor is stopped and automatic protection is disabled. Automatic protection can be enabled only when the temperature is higher than the protection threshold.

Related function parameters

Function code	Name	Description	Default	Modify
P89.32	AI/AO measured temperature	-20.0–200.0°C	0.0°C	<input checked="" type="radio"/>
P96.10	Enabling freezing protection	Freezing protection: The freezing protection signal is activated when the detected temperature is lower than the protection threshold. This signal is ignored if the VFD is running. If the run command is received after the protection has been activated, the protection is terminated and the run command is executed. If a stop command is received after the protection has been activated, the motor is stopped and automatic protection is disabled. Automatic protection can be enabled when the	0	<input type="radio"/>

Function code	Name	Description	Default	Modify
		temperature is higher than the protection threshold. 0: Disable 1: Enable		
P96.11	Temperature sensor type	0: Invalid 1: PT100 2: PT1000 3: KTY84 4: PTC (AO+AI terminal combination) 5: PTC (AI1+10V terminal combination) 6: PTC (AI2+10V terminal combination) Usage of functions 1–4: To select current-type output for AO, connect one end of the temperature resistor to AI1 (voltage-type) and AO1 (current-type), and the other end to GND. Usage of functions 5–6: Connect the PTC sensor between the +10V terminal and AI1 or AI2.	0	<input type="radio"/>
P96.12	Freezing protection threshold	-20.0–20.0°C	-5.0°C	<input type="radio"/>
P96.13	Low temperature pre-alarm threshold	-20.0–20.0°C When the temperature is lower than the value of this function code, the pre-alarm terminal outputs a signal.	0.0°C	<input type="radio"/>
P96.14	Freezing protection frequency	0.00–45.00Hz	0.0Hz	<input type="radio"/>

Related fault codes

Fault code	Fault type	Possible cause	Solution
FrOST	Freezing fault	The temperature is lower than the freezing protection threshold.	Check the temperature.

5.5.25 Condensation protection

Motors can condense in wet and cold environments, leading to motor failure, which can be avoided by outputting a DC current that slightly raises the temperature of the motor surface during work interruptions.

When the external condensation sensor detects intensive condensation, the VFD injects DC current

into the motor to raise the motor surface temperature to prevent condensation.

To implement the function: Set the S digital input terminal function to 91 to enable condensation protection. If this terminal is enabled through external signal, the VFD sends DC current and automatically stops the sending 40s later. If this function needs to be triggered again, re-enable this function terminal. You can set P96.15 to adjust the DC current proportion.

Related function parameters

Function code	Name	Description	Default	Modify
P96.15	Current of triggering condensation protection	0.0–100.0% When an external terminal triggers the condensation protection signal, the VFD transfers DC current and stops the transfer if the duration reaches 40s. The condensation protection signal needs to be triggered again.	30.0%	<input type="radio"/>

5.5.26 Anti-stalling and dry pumping function

Anti-stalling and dry pumping function can effectively avoid motor damage and energy waste.

Prerequisite for selecting the function: The VFD exceeds the stalling current limit, the output frequency is lower than the stalling frequency upper limit, and the duration of this situation exceeds the stalling time.

Related function parameters

Function code	Name	Description	Default	Modify
P96.28	Motor stalling function selection	0: Disable 1: Pre-alarm 2: Faulty	0	<input type="radio"/>
P96.29	Stalling current limit	0.0–300.0%(100.0% corresponds to the motor rated current.)	200.0%	<input type="radio"/>
P96.30	Stalling frequency upper limit	0.00Hz–P00.04 Note: It cannot be lower than 10Hz.	15.00Hz	<input type="radio"/>
P96.31	Stalling detection time	0.0–3600.0s	2.0s	<input type="radio"/>
P96.32	Motor dry pumping function selection	0–2 0: Disable 1: Pre-alarm 2: Faulty	0	<input type="radio"/>
P96.33	Current limit for motor dry pumping	0.0%–100.0%(100.0% corresponds to the motor rated current.)	0.0%	<input type="radio"/>

Function code	Name	Description	Default	Modify
P96.34	Detection time for motor dry pumping	0.0–3600.0s	2.0s	<input type="radio"/>

Related fault codes

Fault code	Fault type	Possible cause	Solution
BLOCK	Stalling fault	The current is greater than the stalling current.	Check for stalling.
Dr	Dry pumping	The current is lower than the current limit for motor dry pumping.	Check whether dry pumping occurred

5.5.27 Speed tracking function

When P01.00=2, the speed-tracking start is valid.

AM: software speed tracking implementation, currently supporting software in both vector control mode 1 and V/F control mode.

Note: In SVC 0, speed tracking cannot be selected, which indicates P01.00 can be 0 or 1.

The software-implemented speed tracking provides three modes, applicable as follows:

- P01.35=1 is suitable for most scenarios
- P01.35=2 is suitable for scenarios with long power outages and very low motor frequency
- P01.35=3 is suitable for scenarios with generative loads

Advanced speed tracking function: for the function code P01.39, only the tens place needs to be adjusted. Some motors may experience oscillation during software speed tracking when using three-phase modulation, so switching to two-phase modulation is recommended.

Related function parameters

Function code	Name	Description	Default	Modify
P01.00	Running mode of start	0: Direct start 1: Start after DC braking 2: Speed tracking restart (not supported in SVC 0 for AMs)	0	<input checked="" type="radio"/>
P01.35	Speed tracking method	0: From stop frequency (Usually selected) 1: From low frequency (Applicable to restart after a long time of coasting to stop) 2: From max. output frequency P00.03 (Applicable to common power generation load)	0	<input type="radio"/>

Function code	Name	Description	Default	Modify
		situation)		
P01.36	Quick/slow selection for speed tracking	1–100s A great value of this parameter indicates a fast rotation-speed tracking speed, but an excessively great value may result in unreliable tracking.	15s	<input type="radio"/>
P01.37	Speed tracking current	30%–200% Closed-loop current reference value (motor) during rotation. Great value of this parameter indicates high reliability of rotation-speed tracking, but an excessively great value may result in VFD overcurrent.	100%	<input type="radio"/>
P01.38	Demagnetization time for speed tracking	0.0–10.0s	Model depended	<input type="radio"/>
P01.39	Advanced control for speed tracking	0x000–0x111 LED ones place: Current giving mode in vector control 0: 120% of current is given during startup, which is switched to the given value based on P01.35 1: The current is given based on P01.35 LED ones place: PWM mode selection 0: 2PH modulation mode 1: Based on P08.40 LED hundreds place: Search direction for speed tracking 0: Allow both forward and reverse search 1: Disallow reverse search	0x110	<input type="radio"/>

5.5.28 Motor thermal protection function

GD270 supports temperature measurement functions for various types of temperature sensors, including PT100/PT1000/KTY84/PTC, etc. For different types of temperature sensors, the following two detection schemes are provided.

Scheme 1: Implemented through the combination of function terminals AI1 and AO1. It requires setting AI1 to voltage type and AO1 to current type. The wiring is as shown in the figure below. This scheme supports all types of temperature sensors.

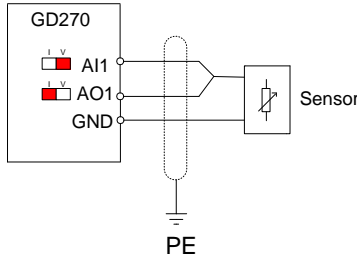
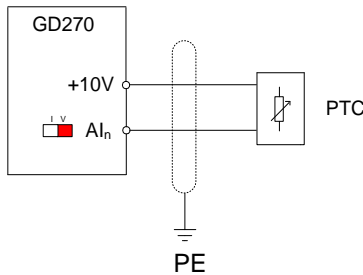

Figure 5-37 AI/AO motor temperature detection wiring diagram

Scheme 2: Implemented through A11 or AI2 and the +10V terminal. It requires setting AI1 or AI2 to voltage type. The wiring is as shown in the figure below. This scheme only supports three-wire PTC sensors that comply with DIN44082 standards. Compared to Scheme 1, it does not require the use of the AO1 terminal.



Related function parameters

Function code	Name	Description	Default	Modify
P96.11	Temperature sensor type	0: Invalid 1: PT100 2: PT1000 3: KTY84 4: PTC (AO+AI terminal combination) 5: PTC (AI1+10V terminal combination) 6: PTC (AI2+10V terminal combination) Usage of functions 1–4: To select current-type output for AO, connect one end of the temperature resistor to AI1 (voltage-type) and AO1 (current-type), and the other end to GND. Usage of functions 5–6: Connect the PTC sensor between the +10V terminal and AI1 or	0	○

Function code	Name	Description	Default	Modify
		AI2.		
P96.35	Motor overtemperature protection threshold	-20.0–200.0	110.0	<input type="radio"/>
P96.36	AI/AO detected temperature offset value	-40.0–40.0	0.0	<input type="radio"/>
P96.37	PTC constant output current setting	0.000–20.000mA	4.000mA	<input type="radio"/>
P96.38	PTC resistance alarm threshold	0–60000Ω	750Ω	<input type="radio"/>
P96.39	PTC resistance alarm recovery threshold	0–60000Ω	150Ω	<input type="radio"/>
P96.40	Actual PTC resistance	0–60000Ω	0Ω	<input checked="" type="radio"/>

5.5.29 Real-time clock function (Keypad with button battery)

Set the current time according to the following figure and check from P92.00 to P92.03.

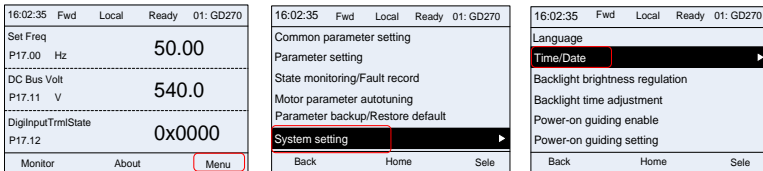

Related function parameters

Function code	Name	Description	Default	Modify
P92.00	Displaying year	2020–2099 YY	2020 YY	<input checked="" type="radio"/>
P92.01	Displaying month and date	01.01–12.31 MMDD	01.01 MMDD	<input checked="" type="radio"/>
P92.02	Displaying day of a week	1–7 : Corresponding to Monday through Sunday	1	<input checked="" type="radio"/>
P92.03	Displaying hour and minute	00.00–23.59 HHMM 00.00 is the earliest hour and time of a day, while 23.59 is the latest hour and time of a day.	00.00 HHMM	<input checked="" type="radio"/>

5.5.30 Fire ride-through control

The fire ride-through function enables the VFD product to respond normally in the event of a fire or when life safety is threatened. Therefore, the fire ride-through mode in GD270 allows the drive to control the motor in a preset manner to assist the building smoke control system during evacuation and firefighting after a fire occurs.

Once a fire trigger signal [S terminal function 79] is input to the VFD and the fire control function code [P93.00] is set to a non-zero value, the VFD enters the fire ride-through mode, controlling the motor to run at the set fire frequency [93.01] and running direction in fire mode [93.02].

Function description	Running conditions
P93.00=0, the VFD runs in normal mode.	The VFD runs in normal mode and stops when encountering a fault.
P93.00=0, fire mode 1 The VFD always runs at the speed specified by P11.54 except when the VFD has been damaged.	<p>1. In fire mode 1, the VFD's target frequency will be forced to run at the fire mode frequency, unaffected by any frequency setting, jog setting, multi-step speed setting, deceleration stop setting, pause setting, emergency stop command, or automatic frequency decrease selection at voltage drop.</p> <p>The running frequency is affected by power-down frequency fall, automatic current limiting, overvoltage stall, and upper/lower frequency limits.</p> <p>2. The VFD will continue to run under any fault, any control command channel, coast to stop command, or keypad run+stop key command (except for STO, STL1, STL2, STL3, and hardware wave blocking faults).</p> <p>If the fire ride-through control is triggered when the VFD is in the Poff state, the VFD will automatically run after the bus voltage is established.</p> <p>3. The motor running direction is set according to the set motor running direction in fire mode, unaffected by P00.13, forward run, reverse run, forward jog, reverse jog, etc.</p>
P93.00=2, fire mode 1 In this mode, the VFD always runs at the speed specified by P11.54, but stops upon the following faults: OUT1, OUT2, OUT3, OC1, OC2, OC3, OV1, OV2, OV3, and SPO.	<p>1. In fire mode 1, the VFD's target frequency will be forced to run at the fire mode frequency, unaffected by any frequency setting, jog setting, multi-step speed setting, deceleration stop setting, pause setting, emergency stop command, or automatic frequency decrease selection at voltage drop.</p> <p>The running frequency is affected by power-down frequency fall, automatic current limiting, overvoltage stall, and upper/lower frequency limits.</p> <p>2. The VFD will run all the time for any control command channel, coast to stop command, or keypad run+stop key command (except STO, STL1, STL2, STL3, hardware blocking fault) except for OUT1, OUT2,</p>

Function description	Running conditions
	OUT3, OC1, OC2, OC3, OV1, OV2, OV3, SPO fault. If the fire ride-through control is triggered when the VFD is in the Poff state, the VFD will automatically run after the bus voltage is established. 3. The motor running direction is set according to the set motor running direction in fire mode, unaffected by P00.13, forward run, reverse run, forward jog, reverse jog, etc.
P93.03 Fire mode flag	If the fire mode has lasted 5 minutes flag is reset to 1. Once the flag is set, no warranty of repair is granted.
P93.04 Actual month and date when fire activated	Time recording function configuration requirement: Select LCD keypad and install a button battery.
P93.05 Actual time when fire activated	Time recording function configuration requirement: Select LCD keypad and install a button battery.

5.5.31 Fault classification

Trigger condition: If the fire ride-through function [P93.00] is invalid, or the fire ride-through function is valid but no fire trigger signal [S terminal function 79] is input to the VFD, the VFD will execute the fault classification function.

GD270 software classifies all faults into 4 levels of protection, with lower numbers indicating higher fault severity.

- Level 0: Coast to stop
- Level 1: Stop according to the stop mode
- Level 2: Pre-alarm and run
- Level 3: Keep running

P11.31–P11.50 set the fault severity for corresponding faults, P11.51 sets the output frequency for warning operation, and P11.52 sets the abnormal backup frequency.

Related function parameters

Function code	Name	Description	Default	Modify
P11.31	Fault severity group 1	0x0000–0x3313 Ones place (fault 11=OL1): 0: Report a fault 1: Report a fault after deceleration to stop 2: Pre-alarm, with the action executed according to P11.51 3: Screen out fault Tens place (fault 12=OL2):	0x0000	○

Function code	Name	Description	Default	Modify
		0: Report a fault 1: Report a fault after deceleration to stop Hundreds place (fault 13=SPI): 0: Report a fault 1: Report a fault after deceleration to stop 2: Pre-alarm, with the action executed according to P11.51 3: Screen out fault Thousands place (fault 14=SPO): 0: Report a fault 1: Report a fault after deceleration to stop 2: Pre-alarm, with the action executed according to P11.51 3: Screen out fault		
P11.32	Fault severity group 2	0x0000–0x3300 Ones place(fault 15=OH1): 0: Report a fault Tens place(fault 16=OH2): 0: Report a fault Hundreds place(fault 17=EF): 0: Report a fault 1: Report a fault after deceleration to stop 2: Pre-alarm, with the action executed according to P11.51 3: Screen out fault Thousands place(fault 18=CE): 0: Report a fault 1: Report a fault after deceleration to stop 2: Pre-alarm, with the action executed according to P11.51 3: Screen out fault	0x0000	○
P11.51	Action for fault alarm	0: Run at the set frequency 1: Run at the output frequency at the time of failure 2: Run at the upper limit frequency 3: Run at the lower limit frequency 4: Run at the backup frequency upon exceptions	0x0000	○

Function code	Name	Description	Default	Modify
P11.52	Backup frequency upon exceptions	0.00Hz–P00.03 (Max. output frequency)	0.00Hz	<input type="radio"/>

5.5.32 Input phase loss detection

Phase loss detection condition: Phase loss cannot be detected when the VFD is stopped or running under no load or light load.

Detection principle: When there is a phase loss and the VFD is under load, the waveform of the bus voltage fluctuation is an asymmetric triangle wave, containing integer harmonics of the fluctuation frequency (100Hz). By extracting the amplitude [P11.29] and duration [P11.30] of the 100Hz component, input phase loss can be determined. Generally, the factory default values do not need to be changed.

Related function parameters

Function code	Name	Description	Default	Modify
P11.28	Software input phase loss detection method	0: Sine-wave detection 1: Square-wave detection Note: Since phase loss detection is implemented through software, output phase loss cannot be detected when the VFD is running without a motor, and input phase loss cannot be detected during no-load or light-load operation. Input phase loss can only be detected normally when the load current is above 60% of the rated current.	1	<input type="radio"/>
P11.29	Software input phase loss detection limit value	0–200.0V Note: Larger values are less likely to report a fault.	40.0V	<input type="radio"/>
P11.30	Software input phase loss detection time	0–20.0s Note: Larger values are less likely to report a fault.	2.0s	<input type="radio"/>

5.5.33 Carrier frequency reduction with temperature

When this function is enabled, to ensure the control performance of the motor at high running frequencies, a certain carrier ratio must be maintained. The reduced carrier frequency must be \geq the minimum carrier frequency (see description for P00.14) and 10 times the output frequency (P00.03), i.e., the reduced carrier frequency $\geq \max(\text{minimum carrier frequency}, \text{P00.03 set value} \times 10)$.

Example: For an 11kW VFD, the default factory value is 4kHz, and the minimum carrier frequency limit is 2kHz. When P00.03 is set to 300Hz and P08.55 is enabled, the reduced carrier frequency $\geq \max(2\text{kHz}, 300\text{Hz} \times 10) = 3\text{kHz}$.

Related function parameters

Function code	Name	Description	Default	Modify
P08.55	Enabling auto carrier frequency reduction	0: Disable 1: Enable Note: Automatic carrier frequency reduction indicates that the VFD automatically reduces the carrier frequency when detecting the heat sink temperature exceeds the rated temperature. When the temperature decreases to a certain degree, the carrier frequency recovers. This function reduces the chance of VFD overheat alarm.	1	<input type="radio"/>
P08.56	Temperature point of auto carrier frequency reduction	40.0–85.0°C	65.0°C	<input type="radio"/>
P08.57	Interval of carrier frequency reduction	0–30Min (Setting it to 0 means carrier frequency reduction is invalid.)	10min	<input type="radio"/>

5.5.34 Cooling fan noise control

GD270 series products in the 160-800kW power range are equipped with speed-adjustable cooling fans. When the VFD load rate is low and the operating environment temperature is good, the fan speed can be reduced by setting the tens place of P08.39 to a percentage value, which can appropriately reduce the operating noise of the VFD.

Related function parameters

Function code	Name	Description	Default	Modify
P08.39	Fan operating mode	0x0000–0x0161 Ones place: Run mode 0: Normal mode 1: Permanent running after power-on Tens place: Set speed 0: 100% 1: 95%	0x0100	<input type="radio"/>

Function code	Name	Description	Default	Modify
		2: 90% 3: 85% 4: 80% 5: 75% 6: 70% Note: Setting this bit can reduce the fan speed, but it may cause the VFD to overheat. Please set it with caution. Hundreds place: Speed control method 0:Tens setting of P08.39 1: Automatic speed regulation		

5.5.35 Grid frequency and voltage selection

Use parameter P08.62 to select the grid frequency (50Hz or 60Hz) and voltage level (380V or 460V) applicable to the VFD. The system will automatically adjust related parameter defaults to ensure proper matching with the power grid and optimize operation.

Function code	Name	Description	Default
P08.62	Grid voltage and frequency selection	Range: 0x00–0x21 Ones place: Frequency selection 0: 50Hz 1: 60Hz Tens place:Voltage selection 0: Indicates the 220V range, suitable for a voltage range of 208–240. 1: Indicates the 380V range, suitable for a voltage range of 380–415. 2: Indicates the 460V range, suitable for a voltage range of 440–480. When the VFD model is -2, the tens place of P08.62 automatically becomes 0. If changed to 1 or 2, it will not take effect. When the VFD model is -4, the tens place of P08.62 defaults to 1. If changed to 0, it will not take effect.	0x10

■ **Grid frequency setting (P08.62 ones place)**

The table below lists parameters whose default values depend on the ones place of P08.62.

Function code	Name	Default value at 50Hz (P08.62 ones place=0)	Default value at 60Hz (P08.62 ones place=1)
P00.03	Max. output frequency	50Hz	60Hz
P00.04	Upper limit of running frequency	50Hz	60Hz
P00.10	Setting frequency through keypad	50Hz	60Hz
P02.02	Rated frequency of AM 1	50Hz	60Hz
P03.16	Forward rotation upper limit frequency set through keypad in torque control	50Hz	60Hz
P03.17	Reverse rotation upper limit frequency set through keypad in torque control	50Hz	60Hz
P08.32	FDT1 electrical level detection value	50Hz	60Hz
P08.34	FDT2 electrical level detection value	50Hz	60Hz
P12.02	Rated frequency of AM 2	50Hz	60Hz
P12.16	Rated frequency of SM 2	50Hz	60Hz

Note: When it is set to 60Hz, the AM default rated speed will be 300rpm higher than the rated speed at 50Hz.

■ Grid voltage setting (P08.62 tens place)

The table below lists parameters whose default values depend on the tens place of P08.62.

Function code	Name	Default value at 380V (P08.62 tens place=1)	Default value at 460V (P08.62 tens place=2)
P02.04	Rated voltage of AM 1	380V: suitable for a voltage range of 380–415V.	460V: suitable for a voltage range of 440–480V.
P11.04	Oversvoltage stall protection voltage	136%	120%

Note:

- After changing P08.62, the default values of related parameters will be automatically updated. However, you may still change them as needed.
- When selecting 60Hz, ensure that the motor's rated speed allows for the increase to avoid overspeed risks.
- Make sure the grid voltage matches the selected setting; otherwise, device protection may be triggered or damage may occur.

It is recommended to reset P08.62 and verify parameter compatibility during initial commissioning or when the power grid changes.

6 Function parameter list

6.1 What this chapter contains

This chapter lists all the function codes and corresponding description of each function code.

6.2 Function parameter list

The function parameters of the VFD are divided into groups by function. Among the function parameter groups, the P98 group is the analog input and output calibration group, while the P99 group contains the factory function parameters, which are user inaccessible. Each group includes several function codes (each function code identifies a function parameter). A three-level menu style is applied to function codes. For example, "P08.08" indicates the 8th function code in the group P8.

The function group numbers correspond to the level-1 menus, the function codes correspond to the level-2 menus, and the function parameters correspond to the level-3 menus.

1. The content of the function code table is as follows:

Column 1 "Function code": Code of the function group and parameter

Column 2 "Name": Full name of the function parameter

Column 3 "Description": Detailed description of the function parameter

Column 4 "Default": Initial value set in factory

Column 5 "Modify": Whether the function parameter can be modified, and conditions for the modification

"○" indicates that the value of the parameter can be modified when the VFD is in stopped or running state.

"◉" indicates that the value of the parameter cannot be modified when the VFD is in running state.

"●" indicates that the value of the parameter is detected and recorded, and cannot be modified.

(The VFD automatically checks and constrains the modification of parameters, which helps prevent incorrect modifications.)

2. The parameters adopt the decimal system (DEC) and hexadecimal system (0–F). If the hexadecimal system is adopted, all bits are mutually independent on data during parameter editing.
3. "Default" indicates the factory setting of the function parameter. If the value of the parameter is detected or recorded, the value cannot be restored to the factory setting.
4. To better protect parameters, the VFD provides the password protection function. After a password is set (that is, P07.00 is set to a non-zero value), "0.0.0.0.0" is displayed when you press the **PRG/ESC** key to enter the function code editing interface. You need to enter the

correct user password to enter the interface. For the factory parameters, you need to enter the correct factory password to enter the interface. (You are not advised to modify the factory parameters. Incorrect parameter setting may cause operation exceptions or even damage to the VFD.) If password protection is not in locked state, you can change the password any time. You can set P07.00 to 0 to cancel the user password. When P07.00 is set to a non-zero value during power-on, parameters are prevented from being modified by using the user password function. When you modify function parameters through serial communication, the user password protection function is also applicable and compliant with the same rule.

Group P00—Basic functions

Function code	Name	Description	Default	Modify
P00.00	Speed control mode	0: SVC mode 0 1: SVC mode 1 2: Space voltage vector control mode Note: Before using a vector control mode (0 or 1), enable the VFD to perform motor parameter autotuning first.	2	☉
P00.01	Channel of running commands	0: Keypad 1: Terminal 2: Communication	0	○
P00.02	Communication mode of running commands	0–5 0: Modbus/Modbus TCP communication 1: PROFIBUS/CANopen /BACnet MSTP communication 2: Ethernet communication 3: PROFINET/EtherNet IP communication 4: Programmable card 5: Wireless communication card Note: The options 1, 2, 3, 4, and 5 are add-on functions and are available only when corresponding expansion cards are configured.	0	○
P00.03	Max. output frequency	The function code is used to set the max. output frequency of the VFD. Pay attention to the function code because it is the foundation of the frequency setting and the speed of acceleration (ACC) and deceleration (DEC). Setting range: Max(P00.04, 10.00)–400.00Hz	50.00Hz	☉
P00.04	Upper limit of	The upper limit of the running frequency is the	50.00Hz	☉

Function code	Name	Description	Default	Modify
	running frequency	upper limit of the output frequency of the VFD, which is lower than or equal to the max. output frequency. When the set frequency is higher than the upper limit of the running frequency, the upper limit of the running frequency is used for running. Setting range: P00.05–P00.03 (Max. output frequency)		
P00.05	Lower limit of running frequency	The lower limit of the running frequency is the lower limit of the output frequency of the VFD, When the set frequency is lower than the lower limit of the running frequency, the lower limit of the running frequency is used for running. Note: Max. output frequency ≥ Upper limit of frequency ≥ Lower limit of frequency Setting range: 0.00Hz–P00.04 (Upper limit of running frequency)	0.00Hz	☉
P00.06	Setting channel of A frequency command	0: Keypad 1: AI1 2: AI2 3: AI3	0	○
P00.07	Setting channel of B frequency command	4: High-speed pulse HDIA 5: Simple PLC program 6: Multi-step speed running 7: PID control 8: Modbus/Modbus TCP communication 9: PROFIBUS/CANopen /BACnet MSTP communication 10: Ethernet communication 11: High-speed pulse HDIB 12: Pulse train AB 13: PROFINET/EtherNet IP communication 14: Programmable card 15–17: Reserved 18: Keypad analog (valid for 1.5–22kW models)	15	○

Function code	Name	Description	Default	Modify																
P00.08	Reference object of B frequency command	0: Max. output frequency 1: A frequency command	0	<input type="radio"/>																
P00.09	Combination mode of setting source	0: A 1: B 2: (A+B) 3: (A-B) 4: Max(A, B) 5: Min(A, B)	0	<input type="radio"/>																
P00.10	Setting frequency through keypad	When A and B frequency commands select the keypad for setting, the value of the function code is the original setting one of the frequency data of the VFD. Setting range: 0.00Hz–P00.03 (Max. output frequency)	50.00Hz	<input type="radio"/>																
P00.11	ACC time 1	ACC time means the time needed if the VFD speeds up from 0Hz to the max. output frequency (P00.03). DEC time means the time needed if the VFD speeds down from the max. output frequency (P00.03) to 0Hz. The VFD has four groups of ACC/DEC time, which can be selected by P05. The factory default ACC/DEC time of the VFD is the first group. Setting range of P00.11 and P00.12: 0.0–3600.0s	Model depended	<input type="radio"/>																
P00.12	DEC time 1		Model depended	<input type="radio"/>																
P00.13	Running direction	0: Run at the default direction. 1: Run at the opposite direction. 2: Disable reverse running.	0	<input type="radio"/>																
P00.14	Carrier frequency setting	<table border="1" style="width: 100%; border-collapse: collapse; text-align: center;"> <thead> <tr> <th style="border: none;">Carrier frequency</th> <th style="border: none;">Electro magnetic noise</th> <th style="border: none;">Noise and leakage current</th> <th style="border: none;">Cooling level</th> </tr> </thead> <tbody> <tr> <td style="border: none;">1kHz</td> <td style="border: none;">↑ High</td> <td style="border: none;">↑ Low</td> <td style="border: none;">↑ Low</td> </tr> <tr> <td style="border: none;">10kHz</td> <td style="border: none;">↓ Low</td> <td style="border: none;">↓ High</td> <td style="border: none;">↓ High</td> </tr> <tr> <td style="border: none;">15kHz</td> <td style="border: none;"></td> <td style="border: none;"></td> <td style="border: none;"></td> </tr> </tbody> </table> <p>The relationship between models and carrier</p>	Carrier frequency	Electro magnetic noise	Noise and leakage current	Cooling level	1kHz	↑ High	↑ Low	↑ Low	10kHz	↓ Low	↓ High	↓ High	15kHz				Model depended	<input type="radio"/>
Carrier frequency	Electro magnetic noise	Noise and leakage current	Cooling level																	
1kHz	↑ High	↑ Low	↑ Low																	
10kHz	↓ Low	↓ High	↓ High																	
15kHz																				

Function code	Name	Description	Default	Modify									
		<p>frequencies is as follows:</p> <table border="1" data-bbox="407 248 813 403"> <thead> <tr> <th data-bbox="407 248 501 308">Model</th> <th data-bbox="501 248 642 308">Default carrier frequency</th> <th data-bbox="642 248 813 308">Minimum carrier frequency</th> </tr> </thead> <tbody> <tr> <td data-bbox="407 312 501 339">1.5–11kW</td> <td data-bbox="501 312 642 339">4kHz</td> <td data-bbox="642 312 813 339">2kHz</td> </tr> <tr> <td data-bbox="407 344 501 403">15kW and higher</td> <td data-bbox="501 344 642 403">2kHz</td> <td data-bbox="642 344 813 403">1.5kHz</td> </tr> </tbody> </table> <p>Advantage of high carrier frequency: ideal current waveform, little current harmonic wave and motor noise.</p> <p>Disadvantage of high carrier frequency: increasing the switch loss, increasing VFD temperature and the impact to the output capacity. The VFD needs to derate on high carrier frequency. At the same time, the leakage and electrical magnetic interference will increase.</p> <p>On the contrary, an extremely-low carrier frequency may cause unstable operation at low frequency, decrease the torque, or even lead to oscillation.</p> <p>The carrier frequency has been properly set in the factory before the VFD is delivered. In general, you do not need to modify it.</p> <p>When the frequency used exceeds the default carrier frequency, the VFD needs to derate by 10% for each increase of 1k carrier frequency.</p> <p>The VFD can be set by P08.55 to enable or disable the function of reducing the carrier frequency with the heatsink temperature (enabled by default). If a consistently high carrier frequency is required for operation, in addition to setting P00.14 to the target value, it is also necessary to set P08.55 to disable.</p> <p>Setting range: 1.0–15.0kHz</p>	Model	Default carrier frequency	Minimum carrier frequency	1.5–11kW	4kHz	2kHz	15kW and higher	2kHz	1.5kHz		
Model	Default carrier frequency	Minimum carrier frequency											
1.5–11kW	4kHz	2kHz											
15kW and higher	2kHz	1.5kHz											
P00.15	Motor parameter autotuning	<p>0: No operation 1: Dynamic autotuning 1 Comprehensive motor parameter autotuning. It is recommended to use rotating autotuning</p>	0	☉									

Function code	Name	Description	Default	Modify
		when high control accuracy is required. 2: Complete parameter static autotuning Used in scenarios where the motor cannot be disconnected from load. 3: Partial parameter static autotuning 1 When the present motor is motor 1, only P02.06, P02.07, and P02.08 are autotuned; when the present motor is motor 2, only P12.06, P12.07, and P12.08 are autotuned. 4: Dynamic autotuning 2; similar to dynamic autotuning 1, but only valid for AMs 5: Partial parameter static autotuning 2 (valid only for AMs)		
P00.16	AVR function selection	0: Invalid 1: Valid during the whole process The auto-adjusting function of the VFD can eliminate the impact on the output voltage of the VFD because of the bus voltage fluctuation.	1	○
P00.17	Reserved	-	-	-
P00.18	Function parameter restoration	0: No operation 1: Restore to default values (excluding motor parameters) 2: Clear fault records 3: Lock keypad parameters 4: Reserved 5: Restore to default values (factory test mode) 6: Restore to default values (including motor parameters) Note: After the selected operation is performed, the function code is automatically restored to 0. Restoring the default values may delete the user password. Exercise caution when using this function.	0	◎

Group P01—Start and stop control

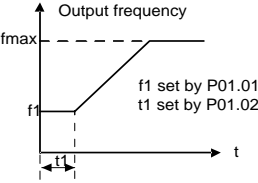
Function code	Name	Description	Default	Modify
P01.00	Running mode of start	0: Direct start 1: Start after DC braking 2: Speed tracking restart (not supported in SVC 0 for AMs) Note: For AMs, speed tracking is not supported in SVC 0, and software speed tracking is supported in other modes. For details, see parameters P01.35–P01.41. For SMs, you do not need to modify parameters P01.35–P01.41.	0	☉
P01.01	Starting frequency of direct start	The function code indicates the initial frequency during VFD start. See P01.02 (Starting frequency hold time) for detailed information. Setting range: 0.00–50.00Hz	0.50Hz	☉
P01.02	Starting frequency hold time	 <p>Setting a proper starting frequency can increase the torque during VFD start. During the hold time of the starting frequency, the output frequency of the VFD is the starting frequency. And then, the VFD runs from the starting frequency to the set frequency. If the set frequency is lower than the starting frequency, the VFD stops running and keeps in the standby state. The starting frequency is not limited in the lower limit frequency. Setting range: 0.0–50.0s</p>	0.0s	☉
P01.03	Braking current before start	The VFD performs DC braking with the braking current before start and it speeds up after the DC braking time. If the set DC braking time is 0, DC braking is invalid. Stronger braking current indicates larger	0.0%	☉
P01.04	Braking time before start		0.00s	☉

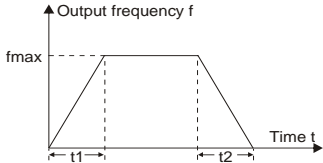
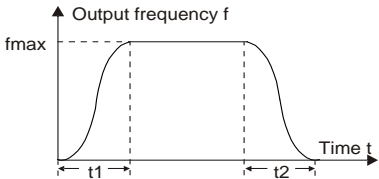
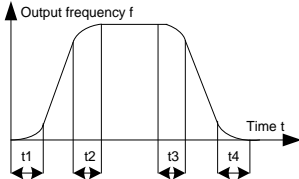
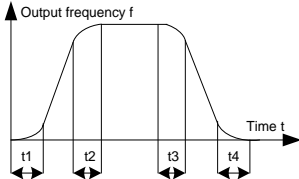
Function code	Name	Description	Default	Modify
		braking power. The DC braking current before start is a percentage of the VFD rated current. Setting range of P01.03: 0.0–100.0% Setting range of P01.04: 0.00–50.00s		
P01.05	ACC and DEC mode	Used to indicate the changing mode of the frequency during start and running. 0: Linear type. The output frequency increases or decreases linearly.  1: S curve. The output frequency increases or decreases according to the S curve. The S curve is generally applied to elevators, conveyors, and other application scenarios where smoother start or stop is required.  Note: If mode 1 is selected, set P01.06, P01.07, P01.27 and P01.28.	0	<input checked="" type="radio"/>
P01.06	Time of starting segment of ACC S curve	The curvature of S curve is determined by the ACC range and ACC/DEC time. 	0.1s	<input checked="" type="radio"/>
P01.07	Time of ending segment of ACC S curve	 t1=P01.06 t2=P01.07 t3=P01.27 t4=P01.28 Setting range: 0.0–50.0s	0.1s	<input checked="" type="radio"/>
P01.08	Stop mode	0: Decelerate to stop After a stop command takes effect, the VFD	0	<input type="radio"/>

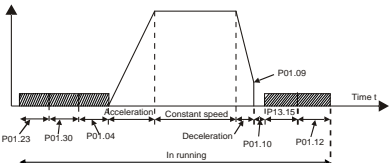
Function code	Name	Description	Default	Modify
		lowers output frequency based on the DEC mode and the defined DEC time; after the frequency drops to the stop speed (P01.15), the VFD stops. 1: Coast to stop After a stop command takes effect, the VFD stops output immediately. And the load coasts to stop according to mechanical inertia.		
P01.09	Starting frequency of braking for stop	Starting frequency of DC braking for stop: During the deceleration to stop, the VFD starts DC braking for stop when running frequency reaches the starting frequency determined by P01.09.	0.00Hz	<input type="radio"/>
P01.10	Demagnetization time	Wait time before DC braking: The VFD blocks the output before starting DC braking. After this wait time, DC braking is started so as to prevent overcurrent caused by DC braking at high speed.	0.00s	<input type="radio"/>
P01.11	DC braking current for stop	DC braking current for stop: It indicates the applied DC braking energy. Stronger current indicates greater DC braking effect.	0.0%	<input type="radio"/>
P01.12	DC braking time for stop	DC braking time for stop: It indicates the hold time of DC braking. If the time is 0, DC braking is invalid, and the VFD decelerates to stop within the specified time. 	0.00s	<input type="radio"/>
		Setting range of P01.09: 0.00Hz–P00.03 (Max. output frequency) Setting range of P01.10: 0.00–30.00s Setting range of P01.11: 0.0–100.0% Setting range of P01.12: 0.0–50.0s		
P01.13	FWD/REV run deadzone time	This function code specifies the transition time of the switching in FWD/REV running switching mode specified by P01.14.	0.0s	<input type="radio"/>

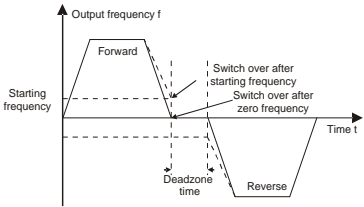
Function code	Name	Description	Default	Modify
		 <p>Setting range: 0.0–3600.0s</p>		
P01.14	FWD/REV run switching mode	0: Switch at zero frequency 1: Switch at the starting frequency 2: Switch after the speed reaches the stop speed with a delay	1	☉
P01.15	Stop speed	0.00–100.00Hz	0.50Hz	☉
P01.16	Stop speed detection mode	0: Detect by the set speed (unique in V/F mode) 1: Detect by the feedback speed	0	☉
P01.17	Stop speed detection time	0.00–100.00s	0.50s	☉
P01.18	Terminal-based running command protection at power-on	When the channel of running commands is terminal control, the system detects the state of the running terminal during power-on. 0: The terminal running command is invalid at power-on Even the running command is considered as valid during power-on, the VFD does not run and it keeps the protection state until the running command is canceled and enabled again. 1: The terminal running command is valid at power-on If the running command is considered as valid during power-on, the VFD is started automatically after the initialization. Note: Exercise caution before using this function. Otherwise, serious results may follow.	0	○
P01.19	Action selected when running	The function code determines the running state of the VFD when the set frequency is	0	☉

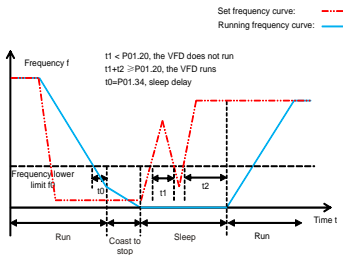
Function code	Name	Description	Default	Modify
	frequency less than frequency lower limit (valid when frequency lower limit greater than 0)	lower than the lower-limit one. 0: Run at the frequency lower limit 1: Stop 2: Sleep The VFD coasts to stop when the set frequency is lower than the lower-limit one. If the set frequency is higher than the lower limit once again and it lasts for the time set by P01.20, the VFD resumes the running state automatically.		
P01.20	Wake-up-from-sleep delay	Specifies the wake-up-from-sleep delay time. When the running frequency of the VFD is lower than the lower limit, the VFD becomes standby. When the set frequency is higher than the lower limit once again and it lasts for the time set by P01.20, the VFD runs automatically.  Setting range: 0.0–3600.0s (valid when P01.19=2)	0.0s	○
P01.21	Power-off restart selection	The function code indicates whether the VFD automatically runs after re-power on. 0: Disable 1: Enable If the restart condition is met, the VFD will run automatically after waiting the time defined by P01.22.	0	○
P01.22	Wait time for restart after power-off	The function code indicates the wait time before the automatic running of the VFD that is re-powered on.	1.0s	○

Function code	Name	Description	Default	Modify
		<p>Setting range: 0.0–3600.0s (Valid only when P01.21=1)</p>		
P01.23	Start delay time	After a VFD running command is given, the VFD is in standby state and restarts with the delay defined by P01.23 to implement brake release. Setting range: 0.0–600.0s	0.0s	<input type="radio"/>
P01.24	Stop speed delay	0.0–600.0s	0.0s	<input type="radio"/>
P01.25	Open-loop 0Hz output selection	0: Output without voltage 1: Output with voltage 2: Output with the DC braking current for stop	0	<input type="radio"/>
P01.26	DEC time for emergency stop	0.0–60.0s	2.0s	<input type="radio"/>
P01.27	Time of starting segment of DEC S curve	0.0–50.0s	0.1s	<input checked="" type="radio"/>
P01.28	Time of ending segment of DEC S curve	0.0–50.0s	0.1s	<input checked="" type="radio"/>
P01.29	Short-circuit braking current	When the VFD starts in direct start mode (P01.00=0), set P01.30 to a non-zero value to enter short-circuit braking.	0.0%	<input type="radio"/>
P01.30	Hold time of short-circuit braking for start	During stop, if the running frequency of VFD is lower than the starting frequency of brake for stop (P01.09), set P01.31 to a non-zero value to enter short-circuit braking for stop, and then carry out DC braking in the time set by P01.12. (Refer to the descriptions for P01.09–P01.12.)	0.00s	<input type="radio"/>
P01.31	Hold time of short-circuit braking for stop	Setting range of P01.29: 0.0–150.0% (of the rated VFD output current) Setting range of P01.30: 0.0–50.0s	0.00s	<input type="radio"/>

Function code	Name	Description	Default	Modify
		Setting range of P01.31: 0.0–50.0s		
P01.32	Pre-exciting time for jogging	0.000–10.000s	0.300s	<input type="radio"/>
P01.33	Starting frequency of braking for stop in jogging	0.00Hz–P00.03	0.00Hz	<input type="radio"/>
P01.34	Sleep delay	0.0–3600.0s	0.0s	<input type="radio"/>
P01.35	Speed tracking method	0: From stop frequency (Usually selected) 1: From low frequency (Applicable to restart after a long time of coasting to stop) 2: From max. output frequency P00.03 (Applicable to common power generation load situation)	0	<input type="radio"/>
P01.36	Quick/slow selection for speed tracking	1–100s A great value of this parameter indicates a fast rotation-speed tracking speed, but an excessively great value may result in poor tracking effect.	15s	<input type="radio"/>
P01.37	Speed tracking current	30%–200% Closed-loop current reference value (motor) during rotation. Great value of this parameter indicates high reliability of rotation-speed tracking, but an excessively great value may result in VFD overcurrent.	100%	<input type="radio"/>
P01.38	Demagnetization time for speed tracking	0.0–10.0s	Model depended	<input type="radio"/>
P01.39	Advanced control for speed tracking	0x000–0x111 Ones place: Current giving mode in vector control 0: 120% of current is given during startup, which is switched to the given value based on P01.35 1: The current is given based on P01.35 Tens place: PWM mode selection 0: 2PH modulation mode 1: Based on P08.40	0x110	<input type="radio"/>

Function code	Name	Description	Default	Modify
		Hundreds place: Search direction of speed tracking 0: Allow both forward and reverse search 1: Disallow reverse search		
P01.40	KP regulation coefficient for speed tracking	0–3000	1500	<input type="radio"/>
P01.41	KI regulation coefficient for speed tracking	0–3000	1500	<input type="radio"/>

Group P02—Parameters of motor 1

Function code	Name	Description	Default	Modify
P02.00	Type of motor 1	0: Asynchronous motor (AM) 1: Synchronous motor (SM)	0	<input checked="" type="radio"/>
P02.01	Rated power of AM 1	0.1–3000.0kW	Model depended (0.4)	<input checked="" type="radio"/>
P02.02	Rated frequency of AM 1	0.01Hz–P00.03 (Max. output frequency)	50.00Hz	<input checked="" type="radio"/>
P02.03	Rated speed of AM 1	1–60000rpm	Model depended (1400)	<input checked="" type="radio"/>
P02.04	Rated voltage of AM 1	0–1200V	Model depended (380)	<input checked="" type="radio"/>
P02.05	Rated current of AM 1	0.8–6000.0A	Model depended (1.0)	<input checked="" type="radio"/>
P02.06	Stator resistance of AM 1	0.001–65.535Ω	Model depended (0.001)	<input type="radio"/>
P02.07	Rotor resistance of AM 1	0.001–65.535Ω	Model depended (0.001)	<input type="radio"/>
P02.08	Leakage inductance of AM 1	0.1–6553.5mH	Model depended (0.1)	<input type="radio"/>

Function code	Name	Description	Default	Modify
P02.09	Mutual inductance of AM 1	0.1–6553.5mH	Model depended (0.1)	<input type="radio"/>
P02.10	No-load current of AM 1	0.1–6553.5A	Model depended (0.1)	<input type="radio"/>
P02.11	Magnetic saturation coefficient 1 of iron core of AM 1	0.0–100.0%	80.0%	<input type="radio"/>
P02.12	Magnetic saturation coefficient 2 of iron core of AM 1	0.0–100.0%	68.0%	<input type="radio"/>
P02.13	Magnetic saturation coefficient 3 of iron core of AM 1	0.0–100.0%	57.0%	<input type="radio"/>
P02.14	Magnetic saturation coefficient 4 of iron core of AM 1	0.0–100.0%	40.0%	<input type="radio"/>
P02.15	Rated power of SM 1	0.1–3000.0kW	Model depended (0.4)	<input checked="" type="radio"/>
P02.16	Rated frequency of SM 1	0.01Hz–P00.03 (Max. output frequency)	50.00Hz	<input checked="" type="radio"/>
P02.17	Number of pole pairs of SM 1	1–128	2	<input checked="" type="radio"/>
P02.18	Rated voltage of SM 1	0–1200V	Model depended (380)	<input checked="" type="radio"/>
P02.19	Rated current of SM 1	0.8–6000.0A	Model depended (1.0)	<input checked="" type="radio"/>
P02.20	Stator resistance of SM 1	0.001–65.535Ω	Model depended (0.001)	<input type="radio"/>
P02.21	Direct-axis inductance of SM 1	0.01–655.35mH	Model depended (0.01)	<input type="radio"/>
P02.22	Quadrature-axis inductance of SM 1	0.01–655.35mH	Model depended (0.01)	<input type="radio"/>

Function code	Name	Description	Default	Modify
P02.23	Counter-emf of SM 1	0–10000	300	<input type="radio"/>
P02.24	Initial pole position of SM 1	0x0000–0xFFFF	0x0000	<input checked="" type="radio"/>
P02.25	Identification current of SM 1	0–50%	10%	<input checked="" type="radio"/>
P02.26	Overload protection selection of motor 1	<p>0: No protection</p> <p>1: Common motor (with low-speed compensation)</p> <p>As the cooling effect of a common motor is degraded at low speed running, the corresponding electronic thermal protection value needs to be adjusted properly, the low compensation indicates lowering the overload protection threshold of the motor whose running frequency is lower than 30Hz.</p> <p>2: Frequency-variable motor (without low-speed compensation)</p> <p>The heat dissipation function for a variable-frequency motor is not impacted by the rotation speed, and therefore it is not necessary to adjust the protection value at low speed running.</p>	2	<input checked="" type="radio"/>
P02.27	Overload protection coefficient of motor 1	<p>Motor overload multiplication $M = I_{out}/(I_n * K)$</p> <p>I_n indicates the rated motor current, I_{out} indicates the VFD output current, and K indicates the motor overload protection coefficient.</p> <p>A smaller value of "K" indicates a bigger value of "M".</p> <p>When M=116%, protection is performed after motor overload lasts for 1 hour; when M=200%, protection is performed after motor overload lasts for 60 seconds; and when $M \geq 400\%$, protection is performed immediately.</p>	100.0%	<input type="radio"/>

Function code	Name	Description	Default	Modify
		<p>Setting range: 20.0–150.0%</p>		
P02.28	Power display calibration coefficient of motor 1	The function code can be used to adjust the power display value of motor 1. However, it does not affect the control performance of the VFD. Setting range: 0.00–3.00	1.00	<input type="radio"/>
P02.29	Parameter display of motor 1	0: Display by motor type In this mode, only parameters related to the present motor type are displayed. 1: Display all In this mode, all the motor parameters are displayed.	0	<input type="radio"/>
P02.30	System inertia of motor 1	0.000–30.000kg·m ²	0.000 kg·m ²	<input type="radio"/>

Group P03—Vector control of motor 1

Function code	Name	Description	Default	Modify
P03.00	Speed-loop proportional gain 1	P03.00–P03.05 are applicable only to vector control. When switching frequency 1 (P03.02) is not reached, the speed-loop PI parameters are: P03.00 and P03.01. When switching frequency 2 (P03.05) is exceeded, the speed-loop PI parameters are: P03.03 and P03.04. PI parameters are obtained according to the linear change of two groups of parameters. See the following figure:	20.0	<input type="radio"/>
P03.01	Speed-loop integral time 1		0.200s	<input type="radio"/>
P03.02	Low-point frequency for switching		5.00Hz	<input type="radio"/>
P03.03	Speed-loop proportional gain 2		20.0	<input type="radio"/>
P03.04	Speed-loop integral time 2		0.200s	<input type="radio"/>

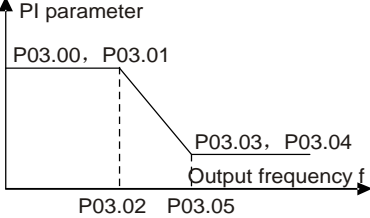
Function code	Name	Description	Default	Modify
P03.05	High-point frequency for switching	<p>↑ PI parameter</p>  <p>The speed loop dynamic response characteristics of vector control can be adjusted by setting the proportional coefficient and integral time of speed regulator. Increasing proportional gain or reducing integral time can accelerate dynamic response of speed loop; however, if the proportional gain is too large or integral time is too small, system oscillation and overshoot may occur; if proportional gain is too small, stable oscillation or speed offset may occur. PI parameters have a close relationship with the inertia of the system. Adjust PI parameters depending on different loads to meet various demands.</p> <p>Setting range of P03.00: 0.0–200.0 Setting range of P03.01: 0.000–10.000s Setting range of P03.02: 0.00Hz –P03.05 Setting range of P03.03: 0.0–200.0 Setting range of P03.04: 0.000–10.000s Setting range of P03.05: P03.02 –P00.03</p>	10.00Hz	○
P03.06	Speed-loop output filter	0–8 (corresponding to 0–2 ⁸ /10ms)	0	○
P03.07	Electromotive slip compensation coefficient of vector control	Slip compensation coefficient is used to adjust the slip frequency of the vector control and improve the speed control accuracy of the system. Adjusting the parameter properly can control the speed steady-state error.	100%	○
P03.08	Power-generation slip compensation coefficient of vector	Setting range: 50–200%	100%	○

Function code	Name	Description	Default	Modify
	control			
P03.09	Current-loop proportional coefficient P	Note: ✧ The two function codes impact the dynamic response speed and control accuracy of the system. Generally, you do not need to modify the two function codes. ✧ Applicable to SVC mode 0 (P00.00=0). ✧ The values of the two function codes are updated automatically after SM parameter autotuning is completed. Setting range: 0–65535	1000	<input type="radio"/>
P03.10	Current-loop integral coefficient I		1000	<input type="radio"/>
P03.11	Torque setting method selection	0–18 0: Keypad (invalid) 1: Keypad (P03.12) 2: AI1 3: AI2 4: AI3 5: Pulse frequency HDIA 6: Multi-step torque 7: Modbus/Modbus TCP communication 8: PROFIBUS/CANopen/BACnet MSTP communication 9: Ethernet communication 10: Pulse frequency HDIB 11: PROFINET/EtherNet IP communication 12: Programmable card 13–17: Reserved 18: Keypad analog (valid for 1.5–22kW models) Note: 100% corresponds to the rated current of motor 1.	0	<input type="radio"/>
P03.12	Torque set through keypad	-300.0%–300.0% (of the rated current of motor 1)	20.0%	<input type="radio"/>
P03.13	Torque reference filter time	0.000–10.000s	0.010s	<input type="radio"/>
P03.14	Setting source of forward rotation frequency upper	0–18 0: Keypad (P03.16) 1: AI1 (100% corresponds to the max.	0	<input type="radio"/>

Function code	Name	Description	Default	Modify
	limit in torque control	frequency) 2: AI2 (same as the above) 3: AI3 (same as the above) 4: Pulse frequency HDIA 5: Multi-step setting (same as the above) 6: Modbus/Modbus TCP communication (same as the above) 7: PROFIBUS/CANopen/BACnet MSTP communication (same as the above) 8: Ethernet communication (same as the above) 9: Pulse frequency HDIB 10: PROFINET/EtherNet IP communication (same as the above) 11: Programmable card (same as the above) 12–17: Reserved 18: Keypad analog (valid for 1.5–22kW models)		
P03.15	Setting source of reverse rotation upper-limit frequency in torque control	0–18 0: Keypad (P03.17) 1: AI1 (100% corresponds to the max. frequency) 2: AI2 (same as the above) 3: AI3 (same as the above) 4: Pulse frequency HDIA 5: Multi-step setting (same as the above) 6: Modbus/Modbus TCP communication (same as the above) 7: PROFIBUS/CANopen/BACnet MSTP communication (same as the above) 8: Ethernet communication (same as the above) 9: Pulse frequency HDIB (Same as the above) 10: PROFINET/EtherNet IP communication (same as the above) 11: Programmable card (same as the above) 12–17: Reserved 18: Keypad analog (valid for 1.5–22kW models)	0	○

Function code	Name	Description	Default	Modify
P03.16	Forward rotation frequency upper limit set through keypad in torque control	Used to set frequency limits. 100% corresponds to the max. frequency. P03.16 specifies the value when P03.14=1, while P03.17 specifies the value when P03.15=1.	50.00Hz	<input type="radio"/>
P03.17	Reverse rotation upper-limit frequency set through keypad in torque control	Setting range: 0.00Hz~P00.03 (Max. output frequency)	50.00Hz	<input type="radio"/>
P03.18	Setting source of electromotive torque upper limit	0-18 0: Keypad (P03.21) 1: AI1 2: AI2 3: AI3 4: Pulse frequency HDIA 5: Modbus/Modbus TCP communication 6: PROFIBUS/CANopen/BACnet MSTP communication 7: Ethernet communication 8: Pulse frequency HDIB 9: PROFINET/EtherNet IP communication 10: Programable card 11-17: Reserved 18: Keypad analog (valid for 1.5-22kW models) Note: 100% corresponds to the rated current of motor 1.	0	<input type="radio"/>
P03.19	Setting source of braking torque upper limit	0-18 0: Keypad (P03.21) 1: AI1 2: AI2 3: AI3 4: Pulse frequency HDIA 5: Modbus/Modbus TCP communication 6: PROFIBUS/CANopen/BACnet MSTP communication 7: Ethernet communication	0	<input type="radio"/>

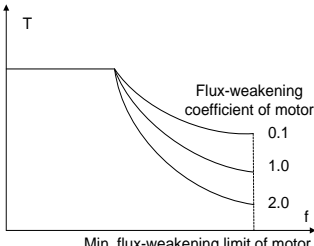
Function code	Name	Description	Default	Modify
		8: Pulse frequency HDIB 9: PROFINET/EtherNet IP communication 10: Programable card 11–17: Reserved 18: Keypad analog (valid for 1.5–22kW models) Note: 100% corresponds to the rated current of motor 1.		
P03.20	Electromotive torque upper limit set through keypad	Used to set torque limits. Setting range: 0.0–300.0% (of the rated voltage of motor 1)	180.0%	<input type="radio"/>
P03.21	Braking torque upper limit set through keypad		180.0%	<input type="radio"/>
P03.22	Weakening coefficient in constant power zone	Used when the AM is in flux-weakening control. 	0.3	<input type="radio"/>
P03.23	Lowest weakening point in constant power zone	The function codes P03.22 and P03.23 are valid at constant power. The motor enters the flux-weakening state when the motor runs above the rated speed. Change the flux-weakening curvature by modifying the flux-weakening control coefficient. The larger the coefficient, the steeper the curve, the smaller the coefficient, the smoother the curve. Setting range of P03.22: 0.1–2.0 Setting range of P03.23: 10%–100.0%	20%	<input type="radio"/>
P03.24	Max. voltage limit	P03.24 sets the max. output voltage of the VFD, which is the percentage of motor rated voltage. Set the value according to onsite	100.0%	<input type="radio"/>

Function code	Name	Description	Default	Modify
		conditions. Setting range: 0.0–120.0% (only valid for SM vector 0 weak magnetism)		
P03.25	Pre-exciting time	Pre-exciting is performed for the motor when the VFD starts up. A magnetic field is built up inside the motor to improve the torque performance during the start process. Setting range: 0.000–10.000s (only valid for SM vector 0 weak magnetism)	0.300s	<input type="radio"/>
P03.26	Flux-weakening proportional gain	0–8000 (only valid for SM vector 0 weak magnetism)	1000	<input type="radio"/>
P03.27	Speed display selection in vector control	0: Display the actual value 1: Display the set value	0	<input type="radio"/>
P03.28	Static friction compensation coefficient	0.0–100.0%	0.0%	<input type="radio"/>
P03.29	Corresponding frequency point of static friction	0.50Hz–P03.31	1.00Hz	<input type="radio"/>
P03.30	High speed friction compensation coefficient	0.0–100.0%	0.0%	<input type="radio"/>
P03.31	Corresponding frequency of high speed friction torque	P03.29–400.00Hz	50.00Hz	<input type="radio"/>
P03.32	Enabling torque control	0: Disable 1: Enable	0	<input checked="" type="radio"/>
P03.33	Flux-weakening integral gain	0–8000	1200	<input type="radio"/>
P03.34	Reserved	-	-	-
P03.35	Control mode optimization selection	Range: 0x0000–0x1111 Ones place: Torque command selection 0: Torque reference 1: Torque current reference Tens place: Reserved Hundreds place: indicates whether to enable	0x0000	<input type="radio"/>

Function code	Name	Description	Default	Modify
		speed-loop integral separation 0: Disable 1: Enable Thousands place: Reserved		
P03.36	Speed-loop differential gain	0.00–10.00s	0.00s	<input type="radio"/>
P03.37	Proportional coefficient of high-frequency current loop	Setting range of P03.37: 0–65535 P03.38 setting range: 0–65535 P03.39 setting range: 0.0–100.0% (of the max. frequency)	1000	<input type="radio"/>
P03.38	High-frequency current-loop integral coefficient		1000	<input type="radio"/>
P03.39	Current-loop high-frequency switching threshold		100.0%	<input type="radio"/>
P03.40	Enabling inertia compensation	0: Disable 1: Enable	0	<input type="radio"/>
P03.41	Upper limit of inertia compensation torque	The max. inertia compensation torque is limited to prevent inertia compensation torque from being too large. Setting range: 0.0–150.0% (of the motor rated torque)	10.0%	<input type="radio"/>
P03.42	Inertia compensation filter times	Filter times of inertia compensation torque, used to smooth inertia compensation torque. Setting range: 0–10	7	<input type="radio"/>
P03.43	Inertia identification torque	Due to friction force, it is required to set certain identification torque for the inertia identification to be performed properly. 0.0–100.0% (of the rated motor torque)	10.0%	<input type="radio"/>
P03.44	Enabling motor inertia identification	0: No operation 1: Enable	0	<input checked="" type="radio"/>
P03.45	Current-loop proportional coefficient after autotuning	0–65535	0	<input type="radio"/>
P03.46	Current-loop integral coefficient after autotuning	0–65535	0	<input type="radio"/>

Group P04—V/F control

Function code	Name	Description	Default	Modify
P04.00	V/F curve setting of motor 1	<p>This group of function code defines the V/F curve of motor 1 to meet the needs of different loads.</p> <p>0: Straight-line V/F curve, applicable to constant torque loads</p> <p>1: Multi-point V/F curve</p> <p>2: Torque-down V/F curve (power of 1.3)</p> <p>3: Torque-down V/F curve (power of 1.7)</p> <p>4: Torque-down V/F curve (power of 2.0)</p> <p>Curves 2 – 4 are applicable to the torque loads such as fans and water pumps. You can adjust according to the characteristics of the loads to achieve best performance.</p> <p>5: Customized V/F (V/F separation); in this mode, V can be separated from F and F can be adjusted through the frequency setting channel set by P00.06 or the voltage setting channel set by P04.27 to change the characteristics of the curve.</p> <p>Note: In the following figure, V_b is the motor rated voltage and f_b is the motor rated frequency.</p>	0	☉
P04.01	Torque boost of motor 1	In order to compensate for low-frequency torque characteristics, you can make some boost compensation for the output voltage.	0.0%	○
P04.02	Torque boost cut-off of motor 1	<p>P04.01 is relative to the max. output voltage V_b.</p> <p>P04.02 defines the percentage of cut-off frequency of manual torque boost to the rated motor frequency f_b. Torque boost can improve the low-frequency torque characteristics of V/F.</p> <p>You need to select torque boost based on the</p>	20.0%	○

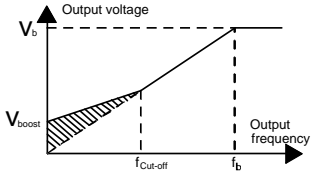
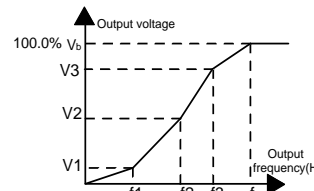
Function code	Name	Description	Default	Modify
		<p>load. For example, larger load requires larger torque boost, however, if the torque boost is too large, the motor will run at over-excitation, which may cause increased output current and motor overheating, thus decreasing the efficiency.</p> <p>When torque boost is set to 0.0%, the VFD uses automatic torque boost.</p> <p>Torque boost cut-off threshold: Below this frequency threshold, torque boost is valid; exceeding this threshold will invalidate torque boost.</p>  <p>Setting range of P04.04: 0.0% (Automatic); 0.1%–10.0% (of the rated voltage of motor 1) Setting range of P04.02: 0.0%–50.0% (of the rated frequency of motor 1)</p>		
P04.03	V/F frequency point 1 of motor 1	When P04.00=1 (multi-dot V/F curve), you can set the V/F curve through P04.03–P04.08.	0.00Hz	<input type="radio"/>
P04.04	V/F voltage point 1 of motor 1	The V/F curve is generally set according to the load characteristics of the motor.	00.0%	<input type="radio"/>
P04.05	V/F frequency point 2 of motor 1	Note: $V_1 < V_2 < V_3$, $f_1 < f_2 < f_3$ Too high voltage for low frequency will cause motor overheat or damage and cause VFD overcurrent stall or overcurrent protection.	0.00Hz	<input type="radio"/>
P04.06	V/F voltage point 2 of motor 1		0.0%	<input type="radio"/>
P04.07	V/F frequency point 3 of motor 1		0.00Hz	<input type="radio"/>
P04.08	V/F voltage point 3 of motor 1		0.0%	<input type="radio"/>
		 <p>Setting range of P04.03: 0.00Hz–P04.05 Setting range of P04.04: 0.0%–110.0% (of the</p>		

Function code	Name	Description	Default	Modify
		rated voltage of motor 1) Setting range of P04.05: P04.03–P04.07 Setting range of P04.06: 0.0%–110.0% (of the rated voltage of motor 1) Setting range of P04.07: P04.05–P02.02 (of the rated frequency of AM 1) or P04.05–P02.16 (of the rated frequency of SM 1) Setting range of P04.08: 0.0%–110.0% (of the rated voltage of motor 1)		
P04.09	V/F slip compensation gain of motor 1	Used to compensate for the motor rotating speed change caused by load change in the space voltage vector mode, and thus improve the rigidity of the mechanical characteristics of the motor. You need to calculate the rated slip frequency of the motor as follows: $\Delta f = f_b - n \cdot p / 60$ Of which, f_b is the rated frequency of the motor, corresponding to function code P02.02. n is the rated rotating speed of the motor, corresponding to function code P02.03. p is the number of pole pairs of the motor. 100.0% corresponds to the rated slip frequency Δf of motor 1. Setting range: 0.0–200.0%	0.0%	<input type="radio"/>
P04.10	Low-frequency oscillation control factor of motor 1	In space voltage vector control mode, the motor, especially the large-power motor, may experience current oscillation at certain frequencies, which may cause unstable motor running, or even VFD overcurrent. You can adjust the two function codes properly to eliminate such phenomenon. Setting range of P04.10: 0–100 Setting range of P04.11: 0–100 Setting range of P04.12: 0.00Hz–P00.03	10	<input type="radio"/>
P04.11	High-frequency oscillation control factor of motor 1		10	<input type="radio"/>
P04.12	Oscillation control threshold of motor 1		30.00Hz	<input type="radio"/>
P04.13	V/F curve setting of motor 2	This group of function code defines the V/F curve of motor 2 to meet the needs of different loads. Range: 0–5 0: Straight-line V/F curve	0	<input checked="" type="radio"/>

Function code	Name	Description	Default	Modify
		1: Multi-point V/F curve 2: Torque-down V/F curve (power of 1.3) 3: Torque-down V/F curve (power of 1.7) 4: Torque-down V/F curve (power of 2.0) 5: Customized V/F curve (V/F separation) Note: Refer to the description for P04.00.		
P04.14	Torque boost of motor 2	Setting range of P04.14: 0.0% (Automatic); 0.1%–10.0% (of the rated voltage of motor 2)	0.0%	<input type="radio"/>
P04.15	Torque boost cut-off of motor 2	Setting range of P04.15: 0.0 –50.0% (of the rated frequency of motor 2) Note: Refer to the descriptions for P04.01 and P04.02.	20.0%	<input type="radio"/>
P04.16	V/F frequency point 1 of motor 2	Setting range of P04.16: 0.00Hz–P04.18 Setting range of P04.17: 0.0%–110.0% (of the rated voltage of motor 2)	0.00Hz	<input type="radio"/>
P04.17	V/F voltage point 1 of motor 2	Setting range of P04.18: P04.16–P04.20	0.0%	<input type="radio"/>
P04.18	V/F frequency point 2 of motor 2	Setting range of P04.19: 0.0%–110.0% (of the rated voltage of motor 2)	0.00Hz	<input type="radio"/>
P04.19	V/F voltage point 2 of motor 2	Setting range of P04.20: P04.18–P12.02 (of the rated frequency of AM 2) or P04.18–P12.16 (of the rated frequency of SM 2)	0.0%	<input type="radio"/>
P04.20	V/F frequency point 3 of motor 2	Setting range of P04.21: 0.0%–110.0% (of the rated voltage of motor 2)	0.00Hz	<input type="radio"/>
P04.21	V/F voltage point 3 of motor 2	Note: Refer to the descriptions for P04.03–P04.08.	0.0%	<input type="radio"/>
P04.22	V/F slip compensation gain of motor 2	Used to compensate for the motor rotating speed change caused by load change in the space voltage vector mode, and thus improve the rigidity of the mechanical characteristics of the motor. You need to calculate the rated slip frequency of the motor as follows: $\Delta f = f_b - n * p / 60$ Of which, f_b is the rated frequency of the motor, corresponding to function code P12.02. n is the rated rotating speed of the motor, corresponding to function code P12.03. p is the number of pole pairs of the motor. 100.0% corresponds to the rated slip frequency Δf of motor 2.	0.0%	<input type="radio"/>

Function code	Name	Description	Default	Modify
		Setting range: 0.0–200.0%		
P04.23	Low-frequency oscillation control factor of motor 2	In space voltage vector control mode, the motor, especially the large-power motor, may experience current oscillation at certain	10	<input type="radio"/>
P04.24	High-frequency oscillation control factor of motor 2	frequencies, which may cause unstable motor running, or even VFD overcurrent. You can adjust the two function codes properly to	10	<input type="radio"/>
P04.25	Oscillation control threshold of motor 2	eliminate such phenomenon. Setting range of P04.23: 0–100 Setting range of P04.24: 0–100 Setting range of P04.25: 0.00Hz–P00.03	30.00Hz	<input type="radio"/>
P04.26	Energy-saving run	0: Disable 1: Automatic energy-saving run In light-load state, the motor can adjust the output voltage automatically to achieve energy saving.	0	<input type="radio"/>
P04.27	Voltage setting channel selection	0–18 0: Keypad (The output voltage is determined by P04.28.) 1: AI1 2: AI2 3: AI3 4: HDIA 5: Multi-step speed running (The setting is determined by group P10.) 6: PID 7: Modbus/Modbus TCP communication 8: PROFIBUS/CANopen /BACnet MSTP communication 9: Ethernet communication 10: HDIB 11: PROFINET/EtherNet IP communication 12: Programmable card 13–17: Reserved 18: Keypad analog (valid for 1.5–22kW models)	0	<input type="radio"/>
P04.28	Voltage set through keypad	The function code is the voltage digital setting when "keypad" is selected as the voltage	100.0%	<input type="radio"/>

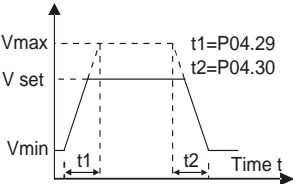
Function code	Name	Description	Default	Modify
		setting channel. Setting range: 0.0%–100.0% (of the rated voltage of motor 1)		
P04.29	Voltage increase time	Voltage increase time means the time needed for the VFD to accelerate from min. output voltage to the max. output frequency.	5.0s	<input type="radio"/>
P04.30	Voltage decrease time	Voltage decrease time means the time needed for the VFD to decelerate from the max. output frequency to min. output voltage. Setting range: 0.0–3600.0s	5.0s	<input type="radio"/>
P04.31	Max. output voltage	The function codes are used to set the upper and lower limits of output voltage.	100.0%	<input checked="" type="radio"/>
P04.32	Min. output voltage	 <p>Setting range of P04.31: P04.32–100.0% (of the motor rated voltage) Setting range of P04.32: 0.0%–P04.31 (of the motor rated voltage)</p>	0.00Hz	<input checked="" type="radio"/>
P04.33	Weakening coefficient in constant power zone	1.00–1.30 Note: P04.33 is only valid for V/F mode.	1.00	<input type="radio"/>
P04.34	Pull-in current 1 in SM V/F control	When the SM V/F control mode is enabled, the function code is used to set the reactive current of the motor when the output frequency is lower than the frequency specified by P04.36. Setting range: -100.0%–+100.0% (of the motor rated current)	20.0%	<input type="radio"/>
P04.35	Pull-in current 2 in SM V/F control	When the SM V/F control mode is enabled, the function code is used to set the reactive current of the motor when the output frequency is greater than the frequency specified by P04.36.	10.0%	<input type="radio"/>

Function code	Name	Description	Default	Modify
		Setting range: -100.0%~+100.0% (of the motor rated current)		
P04.36	Frequency threshold for pull-in current switching in SM V/F control	When the SM VF control mode is enabled, the function code is used to set the frequency threshold for the switching between pull-in current 1 and pull-in current 2. Setting range: 0.0~200.0% (of the motor rated frequency)	20.0%	<input type="radio"/>
P04.37	Reactive current closed-loop proportional coefficient in SM V/F control	When the SM VF control mode is enabled, the function code is used to set the proportional coefficient of reactive current closed-loop control. Setting range: 0~3000	50	<input type="radio"/>
P04.38	Reactive current closed-loop integral time in SM V/F control	When the SM VF control mode is enabled, the function code is used to set the integral coefficient of reactive current closed-loop control. Setting range: 0~3000	30	<input type="radio"/>
P04.39	Reactive current closed-loop output limit in SM VF control	When the SM VF control mode is enabled, the function code is used to set the output limit of the reactive current closed-loop control. A greater value indicates a higher reactive closed-loop compensation voltage and higher output power of the motor. In general, you do not need to modify the function code. Setting range: 0~16000	8000	<input type="radio"/>
P04.40	Enabling IF mode for AM 1	0: Invalid 1: Enable	0	<input checked="" type="radio"/>
P04.41	Current setting in IF mode for AM 1	When IF control is adopted for AM 1, the function code is used to set the output current. The value is a percentage in relative to the rated current of the motor. Setting range: 0.0~200.0%	120.0%	<input type="radio"/>
P04.42	Proportional coefficient in IF mode for AM 1	When IF control is adopted for AM 1, the function code is used to set the proportional coefficient of the output current closed-loop control. Setting range: 0~5000	350	<input type="radio"/>
P04.43	Integral coefficient	When IF control is adopted for AM 1, the	150	<input type="radio"/>

Function code	Name	Description	Default	Modify
	in IF mode for AM 1	function code is used to set the integral coefficient of the output current closed-loop control. Setting range: 0–5000		
P04.44	Starting frequency point for motor 1 switching off IMVF mode	0.00–P04.50	10.00Hz	<input type="radio"/>
P04.45	Enabling IF mode for AM 2	0: Invalid 1: Enable	0	<input checked="" type="radio"/>
P04.46	IMVF current setting	Setting range: 0.0–200.0% (of the motor rated current)	120.0%	<input type="radio"/>
P04.47	Proportional coefficient in IF mode for AM 2	When IF control is adopted for AM 2, the function code is used to set the proportional coefficient of output current closed-loop control. Setting range: 0–5000	350	<input type="radio"/>
P04.48	Integral coefficient in IF mode for AM 2	When IF control is adopted for AM 2, the function code is used to set the integral coefficient of output current closed-loop control. Setting range: 0–5000	150	<input type="radio"/>
P04.49	Starting frequency point for motor 2 switching off IMVF mode	0.00–P04.51	10.00Hz	<input type="radio"/>
P04.50	End frequency point for motor 1 switching off IMVF mode	P04.44–P00.03	25.00Hz	<input type="radio"/>
P04.51	End frequency point for motor 2 switching off IMVF mode	P04.49–P00.03	25.00Hz	<input type="radio"/>
P04.52	VF energy-saving mode selection	0–2 0: Max. efficiency (default) 1: Optimal power factor 2: MTPA	0	<input type="radio"/>

Function code	Name	Description	Default	Modify
P04.53	VF energy-saving gain coefficient	0.0%–400.0%	100.0	○
P04.54	VF energy-saving power angle gain coefficient	0.0%–200.0% Note: A small value of this parameter increases energy saving control effect, but this also reduces the load carrying capability for sudden load.	80.0%	○

Group P05—Input terminals

Function code	Name	Description	Default	Modify
P05.00	HDI input type	0x00–0x11 Ones place: HDIA input type 0: HDIA is high-speed pulse input 1: HDIA is digital input Tens place: HDIB input type (reserved) 0: HDIB is high-speed pulse input (reserved) 1: HDIB is digital input (reserved)	0x00	⊙
P05.01	Function of S1	0–111	1	⊙
P05.02	Function of S2	0: No function	4	⊙
P05.03	Function of S3	1: Run forward	7	⊙
P05.04	Function of S4	2: Run reversely	0	⊙
P05.05	Function of HDIA	3: Three-wire running control	0	⊙
P05.06	Reserved	4: Jog forward	-	-
P05.07	Reserved	5: Jog reversely 6: Coast to stop 7: Fault reset 8: Pause running 9: External fault input 10: Increase frequency setting (UP) 11: Decrease frequency setting (DOWN) 12: Clear the frequency increase/decrease setting 13: Switch between A setting and B setting 14: Switch between combination setting and A setting 15: Switch between combination setting and B setting	-	-

Function code	Name	Description	Default	Modify
		16: Multi-step speed terminal 1 17: Multi-step speed terminal 2 18: Multi-step speed terminal 3 19: Multi-step speed terminal 4 20: Pause multi-step speed running 21: ACC/DEC time selection 1 22: ACC/DEC time selection 2 23: Simple PLC stop reset 24: Pause simple PLC 25: Pause PID control 26: Pause wobbling frequency 27: Reset wobbling frequency 28: Counter reset 29: Switch between speed control and torque control 30: Disable ACC/DEC 31: Trigger the counter 32: Reserved 33: Clear the frequency increase/decrease setting temporarily 34: DC braking 35: Switch from motor 1 to motor 2 36: Switch the running command channel to keypad 37: Switch the running command channel to terminal 38: Switch the running command channel to communication 39: Pre-exciting command 40: Clear electricity consumption 41: Keep electricity consumption 42: Switch the setting source of braking torque upper limit to keypad 43–72: Reserved 73: PID2 start 74: PID2 stop 75: Pause PID2 integral 76: Pause PID2 control		

Function code	Name	Description	Default	Modify												
		77: Switch PID2 polarities 78: Disable HVAC (only in stopped state) 79: Trigger fire signal 80: Pause PID1 control 81: Pause PID1 integral 82: Switch PID1 polarities 83: Trigger sleep mode 84: Trigger wakeup mode 85: Manual alternation 86: Pump cleaning signal 87: Water level upper limit of inlet pool 88: Water level lower limit of inlet pool 89: Water shortage level of inlet pool 90–103: Reserved 104: Disable motor A 105: Disable motor B 106: Disable motor C 107: Disable motor D 108: Disable motor E 109: Disable motor F 110: Disable motor G 111: Disable motor H Note: The output of S4 and Y1 is mutually exclusive, meaning only one can be selected.														
P05.08	Input terminal polarity selection	The function code is used to set the polarity of input terminals. When a bit is 0, the input terminal is positive; when a bit is 1, the input terminal is negative. 0x00–0x3F <table border="1" style="margin-left: 20px;"> <tr> <td>Bit0</td><td>Bit1</td><td>Bit2</td><td>Bit3</td><td>Bit4</td><td>Bit5</td></tr> <tr> <td>S1</td><td>S2</td><td>S3</td><td>S4</td><td>HDIA</td><td>Reserved</td></tr> </table>	Bit0	Bit1	Bit2	Bit3	Bit4	Bit5	S1	S2	S3	S4	HDIA	Reserved	0x00	○
Bit0	Bit1	Bit2	Bit3	Bit4	Bit5											
S1	S2	S3	S4	HDIA	Reserved											
P05.09	Digital input filter time	Used to specify the sampling filter time of the S1–S4, and HDIA terminals. In strong interference cases, increase the value to avoid maloperation. 0.000–1.000s	0.010s	○												
P05.10	Virtual terminal setting	0x00–0x3F (0: disable, 1: enable) <table border="1" style="margin-left: 20px;"> <tr> <td>Bit0</td><td>Bit1</td><td>Bit2</td><td>Bit3</td><td>Bit4</td><td>Bit5</td></tr> </table>	Bit0	Bit1	Bit2	Bit3	Bit4	Bit5	0x00	◎						
Bit0	Bit1	Bit2	Bit3	Bit4	Bit5											

Function code	Name	Description	Default	Modify																														
		<table border="1" data-bbox="421 220 798 248"> <tr> <td>S1</td> <td>S2</td> <td>S3</td> <td>S4</td> <td>HDIA</td> <td>Reserved</td> </tr> </table>	S1	S2	S3	S4	HDIA	Reserved																										
S1	S2	S3	S4	HDIA	Reserved																													
P05.11	Terminal control mode	<p>The function code is used to set the mode of terminal control.</p> <p>0: Two-wire control 1, the enabling consistent with the direction. This mode is widely used. The defined FWD/REV terminal command determines the motor rotation direction.</p> <div data-bbox="415 445 790 652" data-label="Diagram"> <table border="1" data-bbox="626 448 790 652"> <thead> <tr> <th>FWD</th> <th>REV</th> <th>Running command</th> </tr> </thead> <tbody> <tr> <td>OFF</td> <td>OFF</td> <td>Stop</td> </tr> <tr> <td>ON</td> <td>OFF</td> <td>Forward running</td> </tr> <tr> <td>OFF</td> <td>ON</td> <td>Reverse running</td> </tr> <tr> <td>ON</td> <td>ON</td> <td>Hold</td> </tr> </tbody> </table> </div> <p>1: Two-wire control 2, the enabling separated from the direction. In this mode, FWD is the enabling terminal. The direction depends on the defined REV state.</p> <div data-bbox="415 788 790 995" data-label="Diagram"> <table border="1" data-bbox="626 791 790 995"> <thead> <tr> <th>FWD</th> <th>REV</th> <th>Running command</th> </tr> </thead> <tbody> <tr> <td>OFF</td> <td>OFF</td> <td>Stop</td> </tr> <tr> <td>ON</td> <td>OFF</td> <td>Forward running</td> </tr> <tr> <td>OFF</td> <td>ON</td> <td>Stop</td> </tr> <tr> <td>ON</td> <td>ON</td> <td>Reverse running</td> </tr> </tbody> </table> </div> <p>2: Three-wire control 1. This mode defines S_{in} as the enabling terminal, and the running command is generated by FWD, while the direction is controlled by REV. During running, the S_{in} terminal needs to be closed, and when terminal FWD generates a rising edge signal, the VFD starts to run in the direction set by the state of terminal REV; the VFD needs to be stopped by disconnecting terminal S_{in}.</p>	FWD	REV	Running command	OFF	OFF	Stop	ON	OFF	Forward running	OFF	ON	Reverse running	ON	ON	Hold	FWD	REV	Running command	OFF	OFF	Stop	ON	OFF	Forward running	OFF	ON	Stop	ON	ON	Reverse running	0	⊙
FWD	REV	Running command																																
OFF	OFF	Stop																																
ON	OFF	Forward running																																
OFF	ON	Reverse running																																
ON	ON	Hold																																
FWD	REV	Running command																																
OFF	OFF	Stop																																
ON	OFF	Forward running																																
OFF	ON	Stop																																
ON	ON	Reverse running																																

Function code	Name	Description	Default	Modify																
		<div data-bbox="483 220 730 466" data-label="Diagram"> </div> <p data-bbox="402 475 759 528">The direction control is as follows during running:</p> <table border="1" data-bbox="402 531 813 756"> <thead> <tr> <th>S_{in}</th> <th>REV</th> <th>Previous direction</th> <th>Present direction</th> </tr> </thead> <tbody> <tr> <td rowspan="2">ON</td> <td>OFF→ON</td> <td>FWD run</td> <td>REV run</td> </tr> <tr> <td>ON→OFF</td> <td>REV run</td> <td>FWD run</td> </tr> <tr> <td rowspan="2">ON→OFF</td> <td>ON</td> <td colspan="2" rowspan="2">Decelerate to stop</td> </tr> <tr> <td>OFF</td> </tr> </tbody> </table> <p data-bbox="402 762 816 1139">S_{in}: Three-wire control; FWD: Forward running; REV: Reverse running 3: Three-wire control 2. This mode defines S_{in} as the enabling terminal, and the running command is generated by FWD or REV, but the direction is controlled by both FWD and REV. During running, the S_{in} terminal needs to be closed, and terminal FWD or REV generates a rising edge signal to control the running and direction of the VFD; the VFD needs to be stopped by disconnecting terminal S_{in}.</p> <div data-bbox="463 1145 749 1430" data-label="Diagram"> </div>	S _{in}	REV	Previous direction	Present direction	ON	OFF→ON	FWD run	REV run	ON→OFF	REV run	FWD run	ON→OFF	ON	Decelerate to stop		OFF		
S _{in}	REV	Previous direction	Present direction																	
ON	OFF→ON	FWD run	REV run																	
	ON→OFF	REV run	FWD run																	
ON→OFF	ON	Decelerate to stop																		
	OFF																			

Function code	Name	Description	Default	Modify																					
		<table border="1"> <thead> <tr> <th>S_{in}</th> <th>FWD</th> <th>REV</th> <th>Running direction</th> </tr> </thead> <tbody> <tr> <td rowspan="2">ON</td> <td>OFF→ON</td> <td>ON</td> <td>FWD run</td> </tr> <tr> <td></td> <td>OFF</td> <td>FWD run</td> </tr> <tr> <td rowspan="2">ON</td> <td>ON</td> <td rowspan="2">OFF→ON</td> <td>REV run</td> </tr> <tr> <td>OFF</td> <td>REV run</td> </tr> <tr> <td>ON→OFF</td> <td></td> <td></td> <td>Decelerate to stop</td> </tr> </tbody> </table> <p>S_{in}: Three-wire control; FWD: Forward running; REV: Reverse running Note: For two-wire controlled running mode, when the FWD/REV terminal is valid, if the VFD stops due to a stop command given by another source, the VFD does not run again after the stop command disappears even if the control terminal FWD/REV is still valid. To make the VFD run, you need to trigger FWD/REV again, for example, PLC single-cycle stop, fixed-length stop, and valid STOP/RST stop during terminal control. (See P07.04.)</p>	S _{in}	FWD	REV	Running direction	ON	OFF→ON	ON	FWD run		OFF	FWD run	ON	ON	OFF→ON	REV run	OFF	REV run	ON→OFF			Decelerate to stop		
S _{in}	FWD	REV	Running direction																						
ON	OFF→ON	ON	FWD run																						
		OFF	FWD run																						
ON	ON	OFF→ON	REV run																						
	OFF		REV run																						
ON→OFF			Decelerate to stop																						
P05.12	S1 switch-on delay	<p>These function codes specify the delay time corresponding to the electrical level changes when the programmable input terminals switch on or switch off.</p>	0.000s	<input type="radio"/>																					
P05.13	S1 switch-off delay		0.000s	<input type="radio"/>																					
P05.14	S2 switch-on delay		0.000s	<input type="radio"/>																					
P05.15	S2 switch-off delay		0.000s	<input type="radio"/>																					
P05.16	S3 switch-on delay		0.000s	<input type="radio"/>																					
P05.17	S3 switch-off delay		0.000s	<input type="radio"/>																					
P05.18	S4 switch-on delay		0.000s	<input type="radio"/>																					
P05.19	S4 switch-off delay		0.000s	<input type="radio"/>																					
P05.20	HDIA switch-on delay		Setting range: 0.000–50.000s	0.000s	<input type="radio"/>																				
P05.21	HDIA switch-off delay	Note: After a virtual terminal is enabled, the state of the terminal can be changed only in communication mode. The communication address is 0x200A.	0.000s	<input type="radio"/>																					
P05.22	HDIB switch-on delay (reserved)		0.000s	<input type="radio"/>																					
P05.23	HDIB switch-off delay (reserved)		0.000s	<input type="radio"/>																					
P05.24	A11 lower limit	Used to define the relationship between the	0.00V	<input type="radio"/>																					
P05.25	Corresponding	analog input voltage and its corresponding	0.0%	<input type="radio"/>																					

Function code	Name	Description	Default	Modify	
	setting of AI1 lower limit	setting. When the analog input voltage exceeds the range from the upper limit to the lower limit, the upper limit or lower limit is used.			
P05.26	AI1 upper limit		10.00V	<input type="radio"/>	
P05.27	Corresponding setting of AI1 upper limit		When the analog input is current input, 0mA–20mA current corresponds to 0V–10V voltage.	100.0%	<input type="radio"/>
P05.28	AI1 input filter time		0.030s	<input type="radio"/>	
P05.29	AI2 lower limit	In different applications, 100.0% of the analog setting corresponds to different nominal values. See the descriptions of each application section for details.	-10.00V	<input type="radio"/>	
P05.30	Corresponding setting of AI2 lower limit		-100.0%	<input type="radio"/>	
P05.31	AI2 middle value 1		The following figure illustrates the cases of several settings:	0.00V	<input type="radio"/>
P05.32	Corresponding setting of AI2 middle value 1		0.0%	<input type="radio"/>	
P05.33	AI2 middle value 2		0.00V	<input type="radio"/>	
P05.34	Corresponding setting of AI2 middle value 2		0.0%	<input type="radio"/>	
P05.35	AI2 upper limit		10.00V	<input type="radio"/>	
P05.36	Corresponding setting of AI2 upper limit		100.0%	<input type="radio"/>	
P05.37	AI2 input filter time		Input filter time: to adjust the sensitivity of analog input. Increasing the value properly can enhance analog input anti-interference but may reduce the sensitivity of analog input. Note: AI1 supports the 0–10V/0–20mA input. When AI1 selects the 0–20mA input, the corresponding voltage of 20mA is 10V. AI2 supports the -10+10V input. See section 5.5.9 Analog input for function description. Setting range of P05.24: 0.00V–P05.26 Setting range of P05.25: -300.0%–300.0% Setting range of P05.26: P05.24–10.00V Setting range of P05.27: -300.0%–300.0% Setting range of P05.28: 0.000s–10.000s Setting range of P05.29: -10.00V–P05.31 Setting range of P05.30: -300.0%–300.0%	0.030s	<input type="radio"/>

Function code	Name	Description	Default	Modify
		Setting range of P05.31: P05.29 –P05.33 Setting range of P05.32: -300.0% –300.0% Setting range of P05.33: P05.31 –P05.35 Setting range of P05.34: -300.0%–300.0% Setting range of P05.35: P05.33–10.00V Setting range of P05.36: -300.0% –300.0% Setting range of P05.37: 0.000s–10.000s		
P05.38	HDIA high-speed pulse input function selection	0–2 0: Input set through frequency 1–2: Reserved	0	☉
P05.39	HDIA frequency lower limit	0.000 kHz–P05.41	0.000kHz	○
P05.40	Corresponding setting of HDIA frequency lower limit	-300.0%–300.0%	0.0%	○
P05.41	HDIA frequency upper limit	P05.39–50.000kHz	50.000kHz	○
P05.42	Corresponding setting of HDIA upper limit frequency	-300.0%–300.0%	100.0%	○
P05.43	HDIA frequency input filter time	0.000s–10.000s	0.030s	○
P05.44	HDIB high-speed pulse input function selection (reserved)	0–2 0: Input set through frequency 1–2: Reserved	0	☉
P05.45	HDIB frequency lower limit (Reserved)	0.000kHz–P05.47	0.000kHz	○
P05.46	Corresponding setting of HDIB frequency lower limit (reserved)	-300.0%–300.0%	0.0%	○
P05.47	HDIB frequency upper limit (reserved)	P05.45–50.000kHz	50.000 kHz	○

Function code	Name	Description	Default	Modify
P05.48	Corresponding setting of HDIB upper limit frequency (reserved)	-300.0%–300.0%	100.0%	<input type="radio"/>
P05.49	HDIB frequency input filter time (reserved)	0.000–10.000s	0.030s	<input type="radio"/>
P05.50	A11 input signal type	0x00–0x11 Ones place: Input signal type 0: Voltage 1: Current Tens place: Input value unit selection 0: All voltage type 1: Voltage for voltage-type input, current for current-type input Note: After selecting voltage and current inputs for the function code, you also need to install the jumper on the control board in the correct position.	0	<input checked="" type="radio"/>
P05.51– P05.52	Reserved	-	-	-
P05.53	Keypad analog lower limit	0.00V–P05.54	0.00V	<input type="radio"/>
P05.54	Corresponding setting of keypad analog lower limit	-300.0%–300.0%	0.0%	<input type="radio"/>
P05.55	Keypad analog upper limit	P05.56–10.00V	10.00V	<input type="radio"/>
P05.56	Corresponding setting of keypad analog upper limit	-300.0%–300.0%	100.0%	<input type="radio"/>
P05.57	Keypad analog input filter time	0.000s–10.000s	0.030s	<input type="radio"/>

Group P06—Output terminals

Function code	Name	Description	Default	Modify
P06.00	HDO output type (reserved)	0-1 0: Open collector high-speed pulse output 1: Open collector output	0	☉
P06.01	Y1 output	0-68	0	○
P06.02	HDO output selection	0: Invalid 1: Running 2: Running forward	0	○
P06.03	RO1 output selection	3: Running reversely 4: Jogging 5: VFD in fault 6: Frequency level detection FDT1 7: Frequency level detection FDT2 8: Frequency reached 9: Running in zero speed 10: Upper limit frequency reached 11: Frequency lower limit reached 12: Ready for running 13: Pre-exciting 14: Overload pre-alarm 15: Underload pre-alarm 16: Simple PLC stage completed 17: Simple PLC cycle completed 18: Set counting value reached 19: Designated counting value reached 20: External fault is valid 21: Reserved 22: Running time reached 23: MODBUS communication virtual terminal output 24: PROFIBUS/CANopen/BACnet MSTP communication virtual terminal output 25: Ethernet communication virtual terminal output 26: DC bus voltage established 27-32: Reserved 33: In speed limit 34: PROFINET/EtherNet IP communication virtual terminal output	1	○
P06.04	RO2 output		5	○

Function code	Name	Description	Default	Modify
		35: Reserved 36: Speed/position control switchover completed 37: Any frequency reached 38–47: Reserved 48: Fire mode activated 49: Pre-alarm of PID1 feedback too low 50: Pre-alarm of PID1 feedback too high 51: PID1 in sleep 52: PID2 in startup 53: PID2 stopped 54: Indication of run with backup pressure 55: Water shortage indication of inlet pool 56: Pre-alarm output 57: Control variable-frequency circulation motor A 58: Control variable-frequency circulation motor B 59: Control variable-frequency circulation motor C 60: Control variable-frequency circulation motor D 61: Control variable-frequency circulation motor E 62: Control variable-frequency circulation motor F 63: Control variable-frequency circulation motor G 64: Control variable-frequency circulation motor H 65: Low-temperature pre-alarm 66: Stalling pre-alarm 67: Dry-pumping pre-alarm 68: PTC overtemperature pre-alarm		
P06.05	Output terminal polarity selection	The function code is used to set the polarity of output terminals. When a bit is 0, the output terminal is positive. When a bit is 1, the output terminal is negative.	0x00	○

Function code	Name	Description				Default	Modify
		Bit3	Bit2	Bit1	Bit0		
		Reserved	RO1	Reserved	Y1		
		Setting range: 0x0 –0xF					
P06.06	Y1 switch-on delay	The function codes specify the delay time corresponding to the electrical level changes when the programmable output terminals switch on or switch off.				0.000s	○
P06.07	Y1 switch-off delay					0.000s	○
P06.08	Reserved					-	-
P06.09	Reserved					-	-
P06.10	RO1 switch-on delay	<p>Setting range: 0.000–50.000s</p>				0.000s	○
P06.11	RO1 switch-off delay					0.000s	○
P06.12	Reserved	Note: P06.08 and P06.09 are valid only when P06.00=1.				-	-
P06.13	Reserved					-	-
P06.14	AO1 output	0: Running frequency				0	○
P06.15	AO0 output	1: Set frequency				0	○
P06.16	HDO high-speed pulse output (reserved)	2: Ramp reference frequency 3: Rotational speed (10V corresponds to the speed corresponding to the max. output frequency) 4: Output current (10V corresponds to twice the VFD rated current) 5: Output current (10V corresponds to twice the motor rated current) 6: Output voltage (10V corresponds to 1.5 times the inverter unit rated voltage) 7: Output power (10V corresponds to twice the motor rated power) 8: Set torque (10V corresponds to twice the motor rated torque) 9: Output torque (Absolute value, 10V corresponds to twice the motor rated torque) 10: AI1 input (0–10V/0–20mA) 11: AI2 input (0–10V) 12: AI3 input (0–10V/0–20mA) 13: HDIA input (0.00–50.00kHz) 14: Value 1 set through Modbus communication (0–1000) 15: Value 2 set through Modbus communication (0–1000)				0	○

Function code	Name	Description	Default	Modify
		16: Value 1 set through PROFIBUS/CANopen/BACnet MSTP communication (0–1000) 17: Value 2 set through PROFIBUS/CANopen communication (0–1000) 18: Value 1 set through Ethernet communication (0–1000) 19: Value 2 set through Ethernet communication (0–1000) 20: HDIB input value 21: Value 1 set through PROFINET/EtherNet IP (0–1000) 22: Torque current (bipolar, 100% corresponding to 10V) 23: Exciting current (100% corresponding to 10V) 24: Set frequency (bipolar) 25: Ramp reference frequency (bipolar) 26: Rotational speed (bipolar) 27: Value 2 set through PROFINET communication (0–1000) 28: C_AO1 (Reserved) 29: C_AO2 (Reserved) 30: Rotational speed (10V corresponds to the speed corresponding to twice the motor rated frequency) 31: Output torque 32: PID1 output 33: PID2 output 34: PID1 reference value 35: PID1 feedback value 36: PID2 reference value 37: PID2 feedback value 38–39: Reserved 40: Value 0 set through PROFIBUS/CANopen/BACnet MSTP communication 41: Value 0 set through PROFINET/EtherNet IP communication 42–47: Reserved		

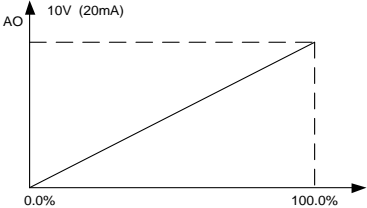
Function code	Name	Description	Default	Modify
P06.17	AO1 output lower limit	The function codes define the relationship between the output value and analog output.	0.0%	<input type="radio"/>
P06.18	AO1 output corresponding to lower limit	When the output value exceeds the allowed range, the output uses the lower limit or upper limit.	0.00V	<input type="radio"/>
P06.19	AO1 output upper limit	When the analog output is current output, 1mA equals 0.5V.	100.0%	<input type="radio"/>
P06.20	AO1 output corresponding to upper limit	In different cases, the corresponding analog output of 100% of the output value is different.	10.00V	<input type="radio"/>
P06.21	AO1 output filter time	 <p>Setting range of P06.17: -300.0%–P06.19 Setting range of P06.18: 0.00V–10.00V Setting range of P06.19: P06.17–300.0% Setting range of P06.20: 0.00V–10.00V Setting range of P06.21: 0.000s–10.000s</p>	0.000s	<input type="radio"/>
P06.22	AO0 output lower limit	-300.0%–P06.23	0.0%	<input type="radio"/>
P06.23	AO0 output corresponding to lower limit	0.00V–10.00V	0.00V	<input type="radio"/>
P06.24	AO0 output upper limit	P06.35–300.0%	100.0%	<input type="radio"/>
P06.25	AO0 output corresponding to upper limit	0.00V–10.00V	10.00V	<input type="radio"/>
P06.26	AO0 output filter time	0.000s–10.000s	0.000s	<input type="radio"/>
P06.27–P06.32	Reserved	-	-	-
P06.33	Detection value for frequency being reached	0.00–P00.03	1.00Hz	<input type="radio"/>

Function code	Name	Description	Default	Modify
P06.34	Frequency reaching detection time	0.0–3600.0s	0.5s	<input type="radio"/>

Group P07—Human-machine interface

Function code	Name	Description	Default	Modify
P07.00	User password	<p>0–65535</p> <p>When you set the function code to a non-zero number, password protection is enabled. If you set the function code to 00000, the previous user password is cleared and password protection is disabled. After the user password is set and takes effect, you cannot enter the parameter menu if you enter an incorrect password. Please remember your password and save it in a secure place.</p> <p>After you exit the function code editing interface, the password protection function is enabled within 1 minute. If password protection is enabled, "0.0.0.0.0" is displayed when you press the PRG/ESC key again to enter the function code editing interface. You need to enter the correct user password to enter the interface.</p> <p>Note: Restoring the default values may delete the user password. Exercise caution when using this function.</p>	0	<input type="radio"/>
P07.01	Parameter copy	<p>Used to set the parameter copy mode.</p> <p>0: No operation 1: Parameter upload to keypad 2: Download all parameters (including motor parameters) 3: Download non-motor parameters 4: Download motor parameters</p> <p>Note: After any operation among 1–4 is completed, the parameter restores to 0. The</p>	0	<input checked="" type="radio"/>

Function code	Name	Description	Default	Modify
		upload and download functions are not applicable to group P29.		
P07.02	Key function selection	Range: 0x00–0x28 Ones place: Function of QUICK/JOG 0: No function 1: Jog 2: Reserved 3: Switch between forward and reverse rotating 4: Clear the UP/DOWN setting 5: Coast to stop 6: Switch command channels in sequence 7: Quick commissioning mode 8: Sequential switching of the run command reference modes + frequency switching Note: When switching to keypad control, the frequency is determined by the setting of P00.10; in other cases, it is determined by P00.06. Tens place: Reserved	0x01	☉
P07.03	Sequence of switching running-command channels by pressing QUICK	When P07.02=6, set the sequence of switching running-command channels by pressing this key. 0: Keypad→Terminal→Communication 1: Keypad←→Terminal 2: Keypad←→Communication 3: Terminal←→Communication	0	○
P07.04	Stop function validity of STOP/RST	Used to specify the stop function validity of STOP/RST . For fault reset, STOP/RST is valid in any conditions. 0: Valid only for keypad control 1: Valid both for keypad and terminal control 2: Valid both for keypad and communication control 3: Valid for all control modes	0	○
P07.05	Selection 1 of parameters displayed in running state	0x0000–0xFFFF Bit 0: Running frequency (HZ on) Bit 1: Set frequency (HZ blinking) Bit2: Bus voltage (V on)	0x03FF	○

Function code	Name	Description	Default	Modify
		Bit3: Output voltage (V on) Bit4: Output current (A on) Bit 5: Running speed (RPM on) Bit6: Output power (% on) Bit7: Output torque (% on) Bit8: PID reference value (% blinking) Bit9: PID feedback value (% on) Bit10: Input terminal status Bit11: Output terminal status Bit12: Set torque (% on) Bit13: Pulse count value Bit14: Motor overload percentage (% on) Bit15: PLC and actual step of multi-step speed		
P07.06	Selection 2 of parameters displayed in running state	0x0000–0xFFFF Bit0: AI1 (V on) Bit 1: AI2 (V on) Bit 2: AI3 (V on) Bit 3: High-speed pulse HDIA frequency Bit 4: Reserved Bit5: VFD overload percentage (% on) Bit 6: Ramp frequency reference (HZ on) Bit7: Linear speed Bit 8: AC incoming current Bit 9: Frequency upper limit Bit 10: AI0 (V on) Bit11–Bit15: Reserved	0x0000	○
P07.07	Selection of parameters displayed in stopped state	0x0000–0xFFFF Bit0: Set frequency (Hz on, blinking slowly) Bit1: Bus voltage (V on) Bit2: Input terminal state Bit3: Output terminal state Bit4: PID reference value (% blinking) Bit5: PID feedback value (% on) Bit6: Set torque (% on) Bit7: AI1 (V on) Bit 8: AI2 (V on) Bit 9: AI3 (V on)	0x00FF	○

Function code	Name	Description	Default	Modify
		Bit 10: High-speed pulse HDIA frequency Bit 11: High-speed pulse HDIB frequency Bit 12: Counting value Bit 13: PLC and current step number of multi-step speed Bit 14: Frequency upper limit Bit 15: AI0 (V on)		
P07.08	Frequency display coefficient	0.01–10.00 Display frequency = Running frequency × P07.08	1.00	○
P07.09	Rotational speed display coefficient	0.1–999.9% Mechanical rotation speed = 120 × (Displayed running frequency) × P07.09 / (Number of motor pole pairs)	100.0%	○
P07.10	Linear speed display coefficient	0.1–999.9% Linear speed = (Mechanical rotation speed) × P07.10	1.0%	○
P07.11	Rectifier bridge temperature	-20.0–120.0°C	0.0°C	●
P07.12	Inverter module temperature	-20.0–120.0°C	0.0°C	●
P07.13	Control board software version	1.00–655.35	Version depended	●
P07.14	Local accumulative running time	0–65535h	0h	●
P07.15	VFD electricity consumption MSB	Used to display the electricity consumption of the VFD.	0kWh	●
P07.16	VFD electricity consumption LSB	VFD electricity consumption = P07.15 × 1000 + P07.16 Setting range of P07.15: 0–65535kWh (×1000) Setting range of P07.16: 0.0–999.9 kWh	0.0kWh	●
P07.17	VFD model	0x0000–0xFFFF1 Bit0–bit3: G type or P type 0x0: G type 0x1: P type Bit4–bit11: Chip type and manufacturer 0x00: DSP(TI)	0x0000	●

Function code	Name	Description	Default	Modify
		0x01–0x20: Reserved 0x21: MCU(ST) 0x22–0xFF: Reserved Bit 12–Bit 15: Reserved		
P07.18	VFD rated power	0.4–3000.0kW	0.4kW	●
P07.19	VFD rated voltage	50–1200V	380V	●
P07.20	VFD rated current	0.1–6000.0A	0.1A	●
P07.21	Factory bar code 1	0x0000–0xFFFF	0xFFFF	●
P07.22	Factory bar code 2	0x0000–0xFFFF	0xFFFF	●
P07.23	Factory bar code 3	0x0000–0xFFFF	0xFFFF	●
P07.24	Factory bar code 4	0x0000–0xFFFF	0xFFFF	●
P07.25	Factory bar code 5	0x0000–0xFFFF	0xFFFF	●
P07.26	Factory bar code 6	0x0000–0xFFFF	0xFFFF	●
P07.27	Present fault type	0: No fault	0	●
P07.28	Last fault type	1: Inverter unit U-phase protection (OUt1)	0	●
P07.29	2nd-last fault type	2: Inverter unit V-phase protection (OUt2)	0	●
P07.30	3rd-last fault type	3: Inverter unit W-phase protection (OUt3)	0	●
P07.31	4th-last fault type	4: Overcurrent during acceleration (OC1)	0	●
P07.32	5th-last fault type	5: Overcurrent during deceleration (OC2) 6: Overcurrent during constant speed running (OC3) 7: Overvoltage during acceleration (OV1) 8: Overvoltage during deceleration (OV2) 9: Overvoltage during constant speed running (OV3) 10: Bus undervoltage fault (UV) 11: Motor overload (OL1) 12: VFD overload (OL2) 13: Phase loss on input side (SPI) 14: Phase loss on output side (SPO) 15: Rectifier module overheat (OH1) 16: Inverter module overheat (OH2) 17: External fault (EF) 18: Modbus/Modbus TCP communication fault (CE) 19: Current detection fault (ItE) 20: Motor autotuning fault (tE) 21: EEPROM operation error (EEP)	0	●

Function code	Name	Description	Default	Modify
		22: PID feedback offline fault (PIDE) 23: Braking unit fault (bCE) 24: Running time reached (END) 25: Electronic overload (OL3) 26: Keypad communication error (PCE) 27: Parameter upload error (UPE) 28: Parameter download error (DNE) 29: PROFIBUS communication fault (E-DP) 30: Ethernet communication fault (E-NET) 31: CANopen communication fault (E-CAN) 32: To-ground short-circuit fault 1 (ETH1) 33: To-ground short-circuit fault 2 (ETH2) 34: Speed deviation fault (dEu) 35: Mal-adjustment fault (STo) 36: Underload fault (LL) 37–39: Reserved 40: Safe torque off (STO) 41: Exception to safety circuit of channel 1 (STL1) 42: Exception to safety circuit of channel 2 (STL2) 43: Exception to both channels 1 and 2 (STL3) 44–54: Reserved 55: Duplicate expansion card type (E-Err) 56: Reserved 57: PROFINET communication fault (E_PN) 58: CAN communication timeout (ESCAN) 59: Motor overtemperature fault (OT) 60: Failure to identify the card in slot 1 (F1-Er) 61: Failure to identify the card in slot 2 (F2-Er) 62: Reserved 63: Communication timeout of the card in slot 1 (C1-Er) 64: Communication timeout of the card in slot 2 (C2-Er) 65–66: Reserved 67: BACnet MSTP communication timeout		

Function code	Name	Description	Default	Modify
		fault (E-BAC) 68: DeviceNet communication timeout fault (E-DEV) 69: CAN slave fault in master/slave synchronization (S-Err) 70: EtherNet IP communication timeout fault (E-EIP) 71: Braking pipe overcurrent fault (bOC) 72: Brake pipe overload (boL) 73: Frost fault (FrOSt) 74: Stalling fault (Block) 75: Dry pumping fault (Dry) 76: AI1 disconnection (E-AI1) 77: AI2 disconnection (E-AI2) 78: AI3 disconnection (E-AI3) 77: Water pipe breaking fault (pbd) 78: Power underload (E-LLP)		
P07.33	Running frequency at present fault	0.00Hz~P00.03	0.00Hz	●
P07.34	Ramp reference frequency at present fault	0.00Hz~P00.03	0.00Hz	●
P07.35	Output voltage at present fault	0~1200V	0V	●
P07.36	Output current at present fault	0.0~6300.0A	0.0A	●
P07.37	Bus voltage at present fault	0.0~2000.0V	0.0V	●
P07.38	Temperature at present fault	-20.0~120.0°C	0.0°C	●
P07.39	Input terminal status at present fault	0x0000~0xFFFF	0x0000	●
P07.40	Output terminal status at present fault	0x0000~0xFFFF	0x0000	●
P07.41	Running frequency at last fault	0.00Hz~P00.03	0.00Hz	●

Function code	Name	Description	Default	Modify
P07.42	Ramp reference frequency at last fault	0.00Hz–P00.03	0.00Hz	●
P07.43	Output voltage at last fault	0–1200V	0V	●
P07.44	Output current at last fault	0.0–6300.0A	0.0A	●
P07.45	Bus voltage at last fault	0.0–2000.0V	0.0V	●
P07.46	Temperature at last fault	-20.0–120.0°C	0.0°C	●
P07.47	Input terminal status at last fault	0x0000–0xFFFF	0x0000	●
P07.48	Output terminal state at last fault	0x0000–0xFFFF	0x0000	●
P07.49	Running frequency at 2nd-last fault	0.00Hz–P00.03	0.00Hz	●
P07.50	Ramp reference frequency at 2nd-last fault	0.00Hz–P00.03	0.00Hz	●
P07.51	Output voltage at 2nd-last fault	0–1200V	0V	●
P07.52	Output current at 2nd-last fault	0.0–6300.0A	0.0A	●
P07.53	Bus voltage at 2nd-last fault	0.0–2000.0V	0.0V	●
P07.54	Temperature at 2nd-last fault	-20.0–120.0°C	0.0°C	●
P07.55	Input terminal status at 2nd-last fault	0x0000–0xFFFF	0x0000	●
P07.56	Output terminal state at 2nd-last fault	0x0000–0xFFFF	0x0000	●

Group P08—Enhanced functions

Function code	Name	Description	Default	Modify
P08.00	ACC time 2	For details, see P00.11 and P00.12.	Model	○

Function code	Name	Description	Default	Modify
		The VFD has four groups of ACC/DEC time, which can be selected by P05.	depended (20.0s)	
P08.01	DEC time 2	The factory default ACC/DEC time of the VFD is the first group. Setting range: 0.0–3600.0s	Model depended (20.0s)	<input type="radio"/>
P08.02	ACC time 3		Model depended (20.0s)	<input type="radio"/>
P08.03	DEC time 3		Model depended (20.0s)	<input type="radio"/>
P08.04	ACC time 4		Model depended (20.0s)	<input type="radio"/>
P08.05	DEC time 4		Model depended (20.0s)	<input type="radio"/>
P08.06	Running frequency of jog		The function code is used to define the reference frequency during jogging. Setting range: 0.00Hz–P00.03 (Max. output frequency)	5.00Hz
P08.07	ACC time for jogging	ACC time for jogging means the time needed for the VFD to accelerate from 0Hz to the max. output frequency (P00.03).	Model depended (20.0s)	<input type="radio"/>
P08.08	DEC time for jogging	DEC time for jogging means the time needed for the VFD to decelerate from the max. output frequency (P00.03) to 0Hz. Setting range: 0.0–3600.0s	Model depended (20.0s)	<input type="radio"/>
P08.09	Jump frequency 1	When the set frequency is within the range of jump frequency, the VFD runs at the boundary of jump frequency. The VFD can avoid mechanical resonance points by setting jump frequencies. The VFD supports the setting of three jump frequencies. If the jump frequency points are set to 0, this function is invalid.	0.00Hz	<input type="radio"/>
P08.10	Jump frequency amplitude 1		0.00Hz	<input type="radio"/>
P08.11	Jump frequency 2		0.00Hz	<input type="radio"/>
P08.12	Jump frequency amplitude 2		0.00Hz	<input type="radio"/>
P08.13	Jump frequency 3		0.00Hz	<input type="radio"/>
P08.14	Jump frequency amplitude 3		0.00Hz	<input type="radio"/>

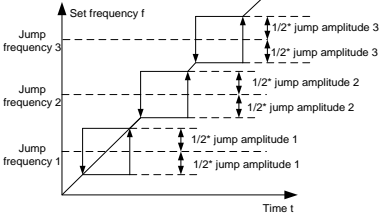
Function code	Name	Description	Default	Modify
		 <p>Setting range: 0.00Hz–P00.03 (Max. output frequency)</p>		
P08.15	Wobbling frequency amplitude percentage	0.0–100.0% (of the set frequency)	0.0%	<input type="radio"/>
P08.16	Amplitude of sudden jump frequency	0.0–50.0% (of the amplitude of wobbling frequency)	0.0%	<input type="radio"/>
P08.17	Rise time of wobbling frequency	0.1–3600.0s	5.0s	<input type="radio"/>
P08.18	Fall time of wobbling frequency	0.1–3600.0s	5.0s	<input type="radio"/>
P08.19	Switching frequency of ACC/DEC time	0.00Hz–P00.03 (Max. output frequency) 0.00: no switchover. If the running frequency is greater than P08.19, switch to ACC/DEC time 2.	0.00Hz	<input type="radio"/>
P08.20	Frequency threshold of the start of drop control	0.00–50.00Hz	2.00Hz	<input type="radio"/>
P08.21	Reference frequency of ACC/DEC time	0: Max. output frequency 1: Set frequency 2: 100Hz Note: Valid only for straight-line ACC/DEC	0	<input checked="" type="radio"/>
P08.22	Output torque calculation method	0: Based on torque current 1: Based on output power	0	<input type="radio"/>
P08.23	Number of decimal points of frequency	0: Two 1: One	0	<input type="radio"/>
P08.24	Number of decimal places of linear	0: No decimal place 1: One	0	<input type="radio"/>

Function code	Name	Description	Default	Modify
	speed	2: Two 3: Three		
P08.25	Set counting value	P08.26–65535	0	<input type="radio"/>
P08.26	Designated counting value	0–P08.25	0	<input type="radio"/>
P08.27	Set running time	0–65535min	0min	<input type="radio"/>
P08.28	Auto fault reset count	Auto fault reset count: When the VFD uses automatic fault reset, it is used to set the number of automatic fault reset times. When the number of continuous reset times exceeds the value, the VFD reports a fault and stops.	0	<input type="radio"/>
P08.29	Auto fault reset interval	Auto fault reset interval: Time interval from when a fault occurred to when automatic fault reset takes effect. After VFD starts, If no fault occurred within 600s after the VFD starts, the number of automatic fault reset times is cleared. Setting range of P08.28: 0–10 Setting range of P08.29: 0.1–3600.0s	1.0s	<input type="radio"/>
P08.30	Frequency decrease ratio in drop control	The output frequency of the VFD changes as the load changes. The function code is mainly used to balance the power when several motors drive a same load. Setting range: 0.00–50.00Hz	0.00Hz	<input type="radio"/>
P08.31	Channel for switching between motor 1 and motor 2	0x00–0x14 Ones place: Switchover channel 0: Terminal 1: Modbus/Modbus TCP communication 2: PROFIBUS/CANopen /BACnet MSTP communication 3: Ethernet communication 4: PROFINET/EtherNet IP communication Tens place: indicates whether to enable switchover during running 0: Disable 1: Enable	0x00	<input checked="" type="radio"/>
P08.32	FDT1 electrical	When the output frequency exceeds the	50.00Hz	<input type="radio"/>

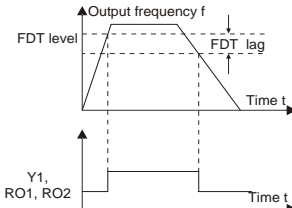
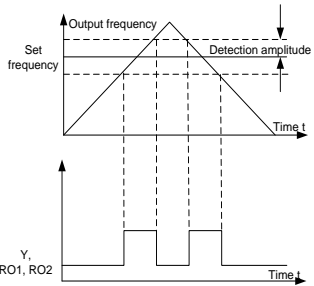
Function code	Name	Description	Default	Modify
	level detection value	corresponding frequency of FDT electrical level, the multifunction digital output terminal continuously outputs the signal of "Frequency level detection FDT". The signal is invalid only when the output frequency decreases to a value lower than the frequency corresponding to (FDT electrical level—FDT lagging detection value).		
P08.33	FDT1 lagging detection value		5.0%	<input type="radio"/>
P08.34	FDT2 electrical level detection value		50.00Hz	<input type="radio"/>
P08.35	FDT2 lagging detection value	 <p>Setting range of P08.32: 0.00Hz–P00.03 Setting range of P08.33: 0.0–100.0% (relative to FDT1 electrical level) Setting range of P08.34: 0.00Hz–P00.03 Setting range of P08.35: 0.0–100.0% (relative to FDT2 electrical level)</p>	5.0%	<input type="radio"/>
P08.36	Detection value for frequency being reached	When the output frequency is within the detection range, the multifunction digital output terminal outputs the signal of "Frequency reached".	0.00Hz	<input type="radio"/>
		 <p>Setting range: 0.00Hz–P00.03 (Max. output frequency)</p>		
P08.37–P08.38	Reserved	-	-	-

Function code	Name	Description	Default	Modify
P08.39	Fan operating mode	0x0000–0x0161 Ones place: Run mode 0: Normal mode 1: Permanent running after power-on Tens place: Set speed 0: 100% 1: 95% 2: 90% 3: 85% 4: 80% 5: 75% 6: 70% Note: Setting this bit can reduce the fan speed, but it may cause the VFD to overheat. Please set it with caution. Hundreds: Speed control method 0:Tens setting of P08.39 1: Automatic speed regulation	0x0100	○
P08.40	PWM selection	0x0000–0x1121 Ones place: PWM mode selection 0: PWM mode 1, 3PH modulation and 2PH modulation 1: PWM mode 2, 3PH modulation Tens place: PWM carrier frequency limit 0: Low-speed carrier frequency limit mode 1 1: Low-speed carrier frequency limit mode 2 2: No limit on carrier frequency Hundreds place: Deadzone compensation method 0: Compensation method 1 1: Compensation method 2 Thousands place: PWM loading mode selection 0: Interruptive loading 1: Normal loading For carrier limit mode 1 and carrier limit mode 2 set in the tens place, the output frequency must be below 3.00 Hz. Mode 2 is limited to 4	0x1101	◎

Function code	Name	Description	Default	Modify
		<p>kHz.</p> <p>In Mode 1 under open-loop vector control, if the output frequency is $\geq 0.40\text{Hz}$, it is limited to 2kHz, and if $< 0.40\text{Hz}$, it is limited to 1kHz.</p> <p>In Mode 1 under closed-loop vector control for motors over 45kW, if the current exceeds 110%, it is limited to 1kHz; if the current is less than 100%, it is limited to 2kHz. For power ratings between 11kW and 45kW, if the current exceeds 110%, it is limited to 2kHz, and if less than 100%, it is limited to 4kHz.</p> <p>The compensation method for the hundreds place: Method 1 is rectangular compensation, and Method 2 is trapezoidal compensation.</p>		
P08.41	Overmodulation selection	<p>0x0000–0x1111</p> <p>Ones place: 0: Disable 1: Enable</p> <p>Tens place: 0: Mild overmodulation 1: Deepened overmodulation</p> <p>Hundreds place: Carrier frequency limit 0: Yes 1: No</p> <p>Thousands place: Output voltage compensation 0: No 1: Yes</p>	0x1000	☉
P08.42	Keypad digital control setting	<p>0x0000–0x1223</p> <p>Ones place: 0: Both the \wedge/\vee key and digital potentiometer can be used for the control. 1: Only the \wedge/\vee key can be used for the control. 2: Only the digital potentiometer can be used for the control. 3: Both the \wedge/\vee key and digital potentiometer can be used for the control.</p>	0x0000	○

Function code	Name	Description	Default	Modify
		<p>Tens place: Frequency control selection</p> <p>0: Valid only when P00.06=0 or P00.07=0</p> <p>1: Valid for all frequency setting methods</p> <p>2: Invalid for multi-step speed running when multi-step speed running has the priority</p> <p>Hundreds place: Action selection for stop</p> <p>0: Setting is valid.</p> <p>1: Valid during running, cleared after stop</p> <p>2: Valid during running, cleared after a stop command is received</p> <p>Thousands place: Integral function of the \wedge/\vee key and digital potentiometer</p> <p>0: Disable the integral function</p> <p>1: Enable the integral function</p>		
P08.43	Keypad digital potentiometer integral rate	0.01–10.00s	0.10s	<input type="radio"/>
P08.44	UP/DOWN terminal control setting	<p>0x000–0x221</p> <p>Ones place: Frequency setting selection</p> <p>0: The setting made through UP/DOWN is valid.</p> <p>1: The setting made through UP/DOWN is invalid.</p> <p>Tens place: Frequency control selection</p> <p>0: Valid only when P00.06=0 or P00.07=0</p> <p>1: Valid for all frequency setting methods</p> <p>2: Invalid for multi-step speed running when multi-step speed running has the priority</p> <p>Hundreds place: Action selection for stop</p> <p>0: Setting is valid.</p> <p>1: Valid during running, cleared after stop</p> <p>2: Valid during running, cleared after a stop command is received</p>	0x000	<input type="radio"/>
P08.45	Frequency increment integral rate of the UP terminal	<p>0.01–50.00Hz/s</p> <p>Note: The value is also used as the frequency increment or decrement that is made by pressing the UP/DOWN key on the LCD keypad.</p>	0.50Hz/s	<input type="radio"/>
P08.46	Frequency integral	0.01–50.00Hz/s	0.50Hz/s	<input type="radio"/>

Function code	Name	Description	Default	Modify
	rate of the DOWN terminal			
P08.47	Action selection at power-off during frequency setting	<p>0x0000–0x1111</p> <p>Ones place: Action selection at power-off during frequency adjusting through digitals. 0: Save the setting at power-off. 1: Clear the setting at power-off.</p> <p>Action selection at power-off during frequency adjusting through Modbus communication 0: Save the setting at power-off. 1: Clear the setting at power-off.</p> <p>Hundreds place: Action selection at power-off during frequency adjusting through DP communication methods 0: Save the setting at power-off. 1: Clear the setting at power-off.</p> <p>Thousands place: Frequency selection for superimposing when switching between A and B sources 0: Enable 1: Disable</p>	0x0000	<input type="radio"/>
P08.48	Initial electricity consumption high bit	Used to set the initial electricity consumption. Initial electricity consumption = P08.48*1000 + P08.49	0kWh	<input type="radio"/>
P08.49	Initial electricity consumption low bit	Setting range of P08.48: 0–59999kWh (k) Setting range of P08.49: 0.0–999.9 kWh	0.0kWh	<input type="radio"/>
P08.50	Magnetic flux braking	<p>0–150 (Used to enable magnetic flux braking.) 0: Invalid 100–150: A larger coefficient indicates stronger braking.</p> <p>The VFD can quickly slow down the motor by increasing the magnetic flux. The energy generated by the motor during braking can be transformed into heat energy by increasing the magnetic flux.</p> <p>The VFD monitors the state of the motor continuously even during the magnetic flux period. Magnetic flux braking can be used for</p>	0	<input type="radio"/>

Function code	Name	Description	Default	Modify
		motor stop, as well as for motor rotation speed change. The other advantages include: Braking is performed immediately after the stop command is given. The braking can be started without waiting for magnetic flux weakening. The cooling is better. The current of the stator other than the rotor increases during magnetic flux braking, while the cooling of the stator is more effective than the rotor.		
P08.51	VFD input power factor	This function code is used to adjust the current display value on the AC input side. 0.00–1.00	0.56	<input type="radio"/>
P08.52	STO lock selection	0–1 0: Lock upon STO alarm 1: No lock on STO alarm Note: "Lock upon STO alarm" indicates resetting is required after state restoration if STO alarm occurs. "No lock on STO alarm" indicates STO alarm disappears automatically after state restoration.	0	<input type="radio"/>
P08.53	Upper limit frequency bias value in torque control	0.00Hz–P00.03 (Max. output frequency) Note: Valid only for torque control.	0.00Hz	<input type="radio"/>
P08.54	Upper limit frequency ACC/DEC selection in torque control	0: No limit on acceleration or deceleration 1: ACC/DEC time 1 2: ACC/DEC time 2 3: ACC/DEC time 3 4: ACC/DEC time 4	0	<input type="radio"/>
P08.55	Enabling auto carrier frequency reduction	0: Disable 1: Enable Note: Automatic carrier frequency reduction indicates that the VFD automatically reduces the carrier frequency when detecting the heat sink temperature exceeds the rated temperature. When the temperature decreases to a certain degree, the carrier frequency recovers. This function reduces the chance of VFD overheat alarm.	1	<input type="radio"/>

Function code	Name	Description	Default	Modify
P08.56	Temperature point of auto carrier frequency reduction	40.0–85.0°C	65.0°C	<input type="radio"/>
P08.57	Interval of carrier frequency reduction	0–30Min (Setting it to 0 means carrier frequency reduction is invalid.)	10	<input type="radio"/>
P08.58	Output phase loss detection delay	0.0–360.0s Note: When the run time exceeds the delay, the VFD detects for output phase loss.	5.0s	<input type="radio"/>
P08.59	AI1 disconnection detection threshold	0–100% (relative to 10V)	0%	<input type="radio"/>
P08.60	AI2 disconnection detection threshold	0–100% (relative to 10V)	0%	<input type="radio"/>
P08.61	AI3 disconnection detection threshold	0–100% (relative to 10V)	0%	<input type="radio"/>
P08.62	Grid voltage and frequency selection	0x00–0x21 Ones place: Frequency selection 0: 50Hz 1: 60Hz Tens place: Voltage selection 0: Indicates the 220V range, suitable for a voltage range of 208–240. 1: Indicates the 380V range, suitable for a voltage range of 380–415. 2: Indicates the 460V range, suitable for a voltage range of 440–480. When the VFD model is -2, the tens place of P08.62 automatically becomes 0. If changed to 1 or 2, it will not take effect. When the VFD model is -4, the tens place of P08.62 defaults to 1. If changed to 0, it will not take effect.	0x10	<input checked="" type="radio"/>

Group P09— PID control

Function code	Name	Description	Default	Modify
P09.00	PID reference source	When P00.06 or P00.07 (Setting channel of A/B frequency command) is 7 or P04.27	0	<input type="radio"/>

Function code	Name	Description	Default	Modify
		<p>(Voltage setting channel) is 6, the VFD is process PID controlled.</p> <p>The function code determines the target given channel during the PID process.</p> <p>0–18</p> <p>0: Keypad (P09.01)</p> <p>1: AI1</p> <p>2: AI2</p> <p>3: AI3</p> <p>4: High-speed pulse HDIA</p> <p>5: Multi-step running</p> <p>6: Modbus/Modbus TCP communication</p> <p>7: PROFIBUS/CANopen /BACnet MSTP communication</p> <p>8: Ethernet communication</p> <p>9: High-speed pulse HDIB</p> <p>10: PROFINET/EtherNet IP communication</p> <p>11: Programmable card</p> <p>12–17: Reserved</p> <p>18: Keypad analog (valid for 1.5–22kW models)</p> <p>The set target of process PID is a relative value, for which 100% equals 100% of the feedback signal of the controlled system.</p> <p>The system always performs calculation by using a relative value (0.0–100.0%).</p>		
P09.01	PID digital setting	<p>The function code is mandatory when P09.00=0. The base value of The function code is the feedback of the system.</p> <p>Setting range: -100.0%–100.0%</p>	0.0%	○
P09.02	PID feedback source	<p>The function code is used to select the PID feedback channel.</p> <p>0–18</p> <p>0: AI1</p> <p>1: AI2</p> <p>2: AI3</p> <p>3: High-speed pulse HDIA</p> <p>4: Modbus/Modbus TCP communication</p>	0	○

Function code	Name	Description	Default	Modify
		5: PROFIBUS/CANopen /BACnet MSTP communication 6: Ethernet communication 7: High-speed pulse HDIB 8: PROFINET/EtherNet IP communication 9: Programmable card 10–17: Reserved 18: Keypad analog (valid for 1.5–22kW models) Note: The reference channel and feedback channel cannot be duplicated. Otherwise, effective PID control cannot be achieved.		
P09.03	PID output characteristics selection	0: PID output is positive. When the feedback signal is greater than the PID reference value, the output frequency of the VFD will decrease to balance the PID. Example: PID control on tension during winding. 1: PID output is negative. When the feedback signal is greater than the PID reference value, the output frequency of the VFD will increase to balance the PID. Example: PID control on tension during unwinding	0	○
P09.04	Proportional gain (Kp)	The function is applied to the proportional gain P of PID input. P determines the strength of the whole PID adjuster. The value 100 indicates that when the difference between the PID feedback value and given value is 100%, the range within which the PID regulator can regulate the output frequency command is the max. frequency (ignoring integral function and differential function). Setting range: 0.00–100.00	1.80	○
P09.05	Integral time (Ti)	Used to determine the speed of the integral adjustment on the deviation of PID feedback and reference from the PID regulator.	0.90s	○

Function code	Name	Description	Default	Modify
		When the deviation of PID feedback and reference is 100%, the integral adjuster works continuously during the time (ignoring proportional and differential function) to achieve the max. output frequency (P00.03) or the max. voltage (P04.31). Shorter integral time indicates stronger adjustment. Setting range: 0.00–10.00s		
P09.06	Differential time (Td)	Used to determine the strength of the change ratio adjustment on the deviation of PID feedback and reference from the PID regulator. If the PID feedback changes 100% during the time, the adjustment of the differential regulator (ignoring proportional and integral function) is the max. output frequency (P00.03) or the max. voltage (P04.31). Longer differential time indicates stronger adjustment. Setting range: 0.00–10.00s	0.00s	<input type="radio"/>
P09.07	Sampling cycle (T)	Used to indicate the sampling cycle of feedback. The regulator calculates in each sampling cycle. A longer sampling cycle indicates slower response. Setting range: 0.001–10.000s	0.001s	<input type="radio"/>
P09.08	PID control deviation limit	The output of the PID system is relative to the max. deviation of the closed loop reference. As shown in the following figure, the PID regulator stops regulating in the range of deviation limit. Set the function parameter properly to adjust the accuracy and stability of the PID system.	0.0%	<input type="radio"/>

Function code	Name	Description	Default	Modify
		<p>Setting range: 0.0–100.0%</p>		
P09.09	PID output upper limit	The function codes are used to set the upper and lower limits of PID regulator output values. 100.0% corresponds to the max. output frequency (P00.03) or max. voltage (P04.31). Setting range of P09.09: P09.10–100.0% Setting range of P09.10: 0.00Hz–P09.09	100.0%	<input type="radio"/>
P09.10	PID output lower limit		0.0%	<input type="radio"/>
P09.11	Feedback offline detection value	The function code is used to set the PID feedback offline detection value. When the feedback value is smaller than or equal to the feedback offline detection value, and the duration exceeds the value specified by P09.12, the VFD reports "PID feedback offline fault" and the keypad displays PIDE.	0.0%	<input type="radio"/>
P09.12	Feedback offline detection time		<p>Setting range of P09.11: 0.0–100.0% Setting range of P09.12: 0.0–3600.0s</p>	1.0s
P09.13	PID control selection	0x0000–0x1111 Ones place: 0: Continue integral control after the frequency reaches upper/lower limit	0x0001	<input type="radio"/>

Function code	Name	Description	Default	Modify
		1: Stop integral control after the frequency reaches upper/lower limit Tens place: 0: Same as the main reference direction 1: Contrary to the main reference direction Hundreds place: 0: Limit as per the max. frequency 1: Limit as per A frequency Thousands place: 0: A+B frequency. Acceleration /deceleration of main reference A frequency source buffering is invalid. 1: A+B frequency. Acceleration /deceleration of main reference A frequency source buffering is valid. Note: The ACC/DEC time is determined by P08.04.		
P09.14	Low frequency proportional gain (Kp)	0.00–100.00 Low-frequency switching point: 5.00Hz, high-frequency switching point: 10.00Hz (P09.04 corresponds to high-frequency parameter), and the middle is the linear interpolation between these two points.	1.00	○
P09.15	ACC/DEC time of PID command	0.0–1000.0s	0.0s	○
P09.16	PID output filter time	0.000–10.000s	0.000s	○
P09.17	Reserved	-	-	-
P09.18	Low frequency integral time (Ti)	0.00–10.00s	0.90s	○
P09.19	Low frequency differential time (Td)	0.00–10.00s	0.00s	○
P09.20	Low frequency point for PID parameter switching	0.00–P09.21	5.00Hz	○
P09.21	High frequency point for PID parameter switching	P09.20–P00.04	10.00Hz	○

Group P10—Simple PLC and multi-step speed control

Function code	Name	Description	Default	Modify
P10.00	Simple PLC mode	0: Stop after running once The VFD stops automatically after running for one cycle, and it can be started only after receiving the running command. 1: Keep running with the final value after running once The VFD keeps the running frequency and direction of the last section after a single cycle. 2: Cyclic running The VFD enters the next cycle after completing one cycle until receiving the stop command.	0	<input type="radio"/>
P10.01	Simple PLC memory selection	0: Do not memorize at power outage 1: Memory at power-off. The PLC memories its running stage and running frequency before power-off.	0	<input type="radio"/>
P10.02	Multi-step speed 0	Frequency setting range for steps from step 0 to step 15: -300.0% –300.0%. 300.0% corresponds to the max. output frequency P00.03. Running time setting range for steps from step 0 to step 15: 0.0–6553.5s(min). The time unit is specified by P10.37 (s: P10.37=0, min: P10.37=1). When simple PLC operation is selected, it is required to set P10.02–P10.33 to determine the running frequency and running time of each step. Note: The symbol of multi-step speed determines the running direction of simple PLC, and the negative value means reverse running.	0.0%	<input type="radio"/>
P10.03	Running time of step 0		0.0s (min)	<input type="radio"/>
P10.04	Multi-step speed 1		0.0%	<input type="radio"/>
P10.05	Running time of step 1		0.0s (min)	<input type="radio"/>
P10.06	Multi-step speed 2		0.0%	<input type="radio"/>
P10.07	Running time of step 2		0.0s (min)	<input type="radio"/>
P10.08	Multi-step speed 3		0.0%	<input type="radio"/>
P10.09	Running time of step 3		0.0s (min)	<input type="radio"/>
P10.10	Multi-step speed 4		0.0%	<input type="radio"/>
P10.11	Running time of step 4		0.0s (min)	<input type="radio"/>
P10.12	Multi-step speed 5		0.0%	<input type="radio"/>
P10.13	Running time of step 5		0.0s (min)	<input type="radio"/>
P10.14	Multi-step speed 6		0.0%	<input type="radio"/>

Function code	Name	Description	Default	Modify						
P10.15	Running time of step 6	<p>The diagram shows a speed profile with two acceleration sections (P10.02 to P10.04 and P10.05 to P10.06) and two deceleration sections (P10.04 to P10.07 and P10.28 to P10.30). Parameters P10.03, P10.05, P10.07, P10.31, and P10.33 indicate specific time points or durations.</p>	0.0s (min)	<input type="radio"/>						
P10.16	Multi-step speed 7		0.0%	<input type="radio"/>						
P10.17	Running time of step 7		0.0s (min)	<input type="radio"/>						
P10.18	Multi-step speed 8		0.0%	<input type="radio"/>						
P10.19	Running time of step 8	When selecting multi-step speed running, the multi-step speed is within the range of	0.0s (min)	<input type="radio"/>						
P10.20	Multi-step speed 9	-fmax~fmax, and it can be set continuously.	0.0%	<input type="radio"/>						
P10.21	Running time of step 9	The start-up and stop of multi-step speed is determined by the function code P00.01.	0.0s (min)	<input type="radio"/>						
P10.22	Multi-step speed 10	The VFD supports the setting of 16-step speed, which are set by combined codes of multi-step terminals 1~4 set by S terminals,	0.0%	<input type="radio"/>						
P10.23	Running time of step 10	corresponding to function code	0.0s (min)	<input type="radio"/>						
P10.24	Multi-step speed 11	P05.01~P05.06) and correspond to multi-step	0.0%	<input type="radio"/>						
P10.25	Running time of step 11	speed 0 to multi-step speed 15.	0.0s (min)	<input type="radio"/>						
P10.26	Multi-step speed 12	<p>The diagram shows a 16-step speed profile with output frequency on the y-axis and time on the x-axis. Steps are numbered 0 to 15. Below the frequency graph, four terminal state waveforms (terminal 1, 2, 3, 4) are shown as ON/OFF pulses corresponding to the steps.</p>	0.0%	<input type="radio"/>						
P10.27	Running time of step 12		0.0s (min)	<input type="radio"/>						
P10.28	Multi-step speed 13		0.0%	<input type="radio"/>						
P10.29	Running time of step 13		0.0s (min)	<input type="radio"/>						
P10.30	Multi-step speed 14		0.0%	<input type="radio"/>						
P10.31	Running time of step 14		0.0s (min)	<input type="radio"/>						
P10.32	Multi-step speed 15		When terminal 1, terminal 2, terminal 3, and terminal 4 are off, the frequency input method is specified by P00.06 or P00.07. When terminal 1, terminal 2, terminal 3 and terminal 4 are not all OFF, the frequency set by multi-step speed will prevail, and the priority of multi-step setting is higher than that of the keypad, analog, high-speed pulse, PID, and communication settings.	0.0%	<input type="radio"/>					
P10.33	Running time of step 15		The relation between terminal 1, terminal 2, terminal 3 and terminal 4 are shown in the following:	0.0s (min)	<input type="radio"/>					
			<table border="1"> <tr> <td>Terminal 1</td> <td>OFF</td> <td>ON</td> <td>OFF</td> <td>ON</td> <td>OFF</td> <td>ON</td> <td>OFF</td> <td>ON</td> </tr> </table>			Terminal 1	OFF	ON	OFF	ON
Terminal 1	OFF		ON	OFF	ON	OFF	ON	OFF	ON	

Function code	Name	Description	Default	Modify																																																																																																																									
		<table border="1"> <tr><td>Terminal 2</td><td>OFF</td><td>OFF</td><td>ON</td><td>ON</td><td>OFF</td><td>OFF</td><td>ON</td><td>ON</td></tr> <tr><td>Terminal 3</td><td>OFF</td><td>OFF</td><td>OFF</td><td>OFF</td><td>ON</td><td>ON</td><td>ON</td><td>ON</td></tr> <tr><td>Terminal 4</td><td>OFF</td><td>OFF</td><td>OFF</td><td>OFF</td><td>OFF</td><td>OFF</td><td>OFF</td><td>OFF</td></tr> <tr><td>Step</td><td>0</td><td>1</td><td>2</td><td>3</td><td>4</td><td>5</td><td>6</td><td>7</td></tr> <tr><td>Terminal 1</td><td>OFF</td><td>ON</td><td>OFF</td><td>ON</td><td>OFF</td><td>ON</td><td>OFF</td><td>ON</td></tr> <tr><td>Terminal 2</td><td>OFF</td><td>OFF</td><td>ON</td><td>ON</td><td>OFF</td><td>OFF</td><td>ON</td><td>ON</td></tr> <tr><td>Terminal 3</td><td>OFF</td><td>OFF</td><td>OFF</td><td>OFF</td><td>ON</td><td>ON</td><td>ON</td><td>ON</td></tr> <tr><td>Terminal 4</td><td>ON</td><td>ON</td><td>ON</td><td>ON</td><td>ON</td><td>ON</td><td>ON</td><td>ON</td></tr> <tr><td>Step</td><td>8</td><td>9</td><td>10</td><td>11</td><td>12</td><td>13</td><td>14</td><td>15</td></tr> </table>	Terminal 2	OFF	OFF	ON	ON	OFF	OFF	ON	ON	Terminal 3	OFF	OFF	OFF	OFF	ON	ON	ON	ON	Terminal 4	OFF	OFF	OFF	OFF	OFF	OFF	OFF	OFF	Step	0	1	2	3	4	5	6	7	Terminal 1	OFF	ON	OFF	ON	OFF	ON	OFF	ON	Terminal 2	OFF	OFF	ON	ON	OFF	OFF	ON	ON	Terminal 3	OFF	OFF	OFF	OFF	ON	ON	ON	ON	Terminal 4	ON	ON	ON	ON	ON	ON	ON	ON	Step	8	9	10	11	12	13	14	15																																										
Terminal 2	OFF	OFF	ON	ON	OFF	OFF	ON	ON																																																																																																																					
Terminal 3	OFF	OFF	OFF	OFF	ON	ON	ON	ON																																																																																																																					
Terminal 4	OFF	OFF	OFF	OFF	OFF	OFF	OFF	OFF																																																																																																																					
Step	0	1	2	3	4	5	6	7																																																																																																																					
Terminal 1	OFF	ON	OFF	ON	OFF	ON	OFF	ON																																																																																																																					
Terminal 2	OFF	OFF	ON	ON	OFF	OFF	ON	ON																																																																																																																					
Terminal 3	OFF	OFF	OFF	OFF	ON	ON	ON	ON																																																																																																																					
Terminal 4	ON	ON	ON	ON	ON	ON	ON	ON																																																																																																																					
Step	8	9	10	11	12	13	14	15																																																																																																																					
P10.34	ACC/DEC time for steps 0–7	0x0000–0xFFFF. See the following table for details:	0x0000	○																																																																																																																									
P10.35	ACC/DEC time for steps 8–15	<table border="1"> <thead> <tr> <th>Function code</th> <th>Binary</th> <th>Step</th> <th>ACC/DEC time 1</th> <th>ACC/DEC time 2</th> <th>ACC/DEC time 3</th> <th>ACC/DEC time 4</th> </tr> </thead> <tbody> <tr><td rowspan="8">P10.34</td><td>Bit1</td><td>Bit0</td><td>0</td><td>00</td><td>01</td><td>10</td><td>11</td></tr> <tr><td>Bit3</td><td>Bit2</td><td>1</td><td>00</td><td>01</td><td>10</td><td>11</td></tr> <tr><td>Bit5</td><td>Bit4</td><td>2</td><td>00</td><td>01</td><td>10</td><td>11</td></tr> <tr><td>Bit7</td><td>Bit6</td><td>3</td><td>00</td><td>01</td><td>10</td><td>11</td></tr> <tr><td>Bit9</td><td>Bit8</td><td>4</td><td>00</td><td>01</td><td>10</td><td>11</td></tr> <tr><td>Bit11</td><td>Bit10</td><td>5</td><td>00</td><td>01</td><td>10</td><td>11</td></tr> <tr><td>Bit13</td><td>Bit12</td><td>6</td><td>00</td><td>01</td><td>10</td><td>11</td></tr> <tr><td>Bit15</td><td>Bit14</td><td>7</td><td>00</td><td>01</td><td>10</td><td>11</td></tr> <tr><td rowspan="8">P10.35</td><td>Bit1</td><td>Bit0</td><td>8</td><td>00</td><td>01</td><td>10</td><td>11</td></tr> <tr><td>Bit3</td><td>Bit2</td><td>9</td><td>00</td><td>01</td><td>10</td><td>11</td></tr> <tr><td>Bit5</td><td>Bit4</td><td>10</td><td>00</td><td>01</td><td>10</td><td>11</td></tr> <tr><td>Bit7</td><td>Bit6</td><td>11</td><td>00</td><td>01</td><td>10</td><td>11</td></tr> <tr><td>Bit9</td><td>Bit8</td><td>12</td><td>00</td><td>01</td><td>10</td><td>11</td></tr> <tr><td>Bit11</td><td>Bit10</td><td>13</td><td>00</td><td>01</td><td>10</td><td>11</td></tr> <tr><td>Bit13</td><td>Bit12</td><td>14</td><td>00</td><td>01</td><td>10</td><td>11</td></tr> <tr><td>Bit15</td><td>Bit14</td><td>15</td><td>00</td><td>01</td><td>10</td><td>11</td></tr> </tbody> </table> <p>Select corresponding acceleration/deceleration time, and then convert 16-bit binary number into hexadecimal number, finally, and then set corresponding function codes. ACC/DEC time 1 is set by P00.11 and P00.12; ACC/DEC time 2 is set by P08.00 and P08.01; ACC/DEC time 3 is set by P08.02 and P08.03; ACC/DEC time 4 is set by P08.04 and</p>	Function code	Binary	Step	ACC/DEC time 1	ACC/DEC time 2	ACC/DEC time 3	ACC/DEC time 4	P10.34	Bit1	Bit0	0	00	01	10	11	Bit3	Bit2	1	00	01	10	11	Bit5	Bit4	2	00	01	10	11	Bit7	Bit6	3	00	01	10	11	Bit9	Bit8	4	00	01	10	11	Bit11	Bit10	5	00	01	10	11	Bit13	Bit12	6	00	01	10	11	Bit15	Bit14	7	00	01	10	11	P10.35	Bit1	Bit0	8	00	01	10	11	Bit3	Bit2	9	00	01	10	11	Bit5	Bit4	10	00	01	10	11	Bit7	Bit6	11	00	01	10	11	Bit9	Bit8	12	00	01	10	11	Bit11	Bit10	13	00	01	10	11	Bit13	Bit12	14	00	01	10	11	Bit15	Bit14	15	00	01	10	11	0x0000	○
Function code	Binary	Step	ACC/DEC time 1	ACC/DEC time 2	ACC/DEC time 3	ACC/DEC time 4																																																																																																																							
P10.34	Bit1	Bit0	0	00	01	10	11																																																																																																																						
	Bit3	Bit2	1	00	01	10	11																																																																																																																						
	Bit5	Bit4	2	00	01	10	11																																																																																																																						
	Bit7	Bit6	3	00	01	10	11																																																																																																																						
	Bit9	Bit8	4	00	01	10	11																																																																																																																						
	Bit11	Bit10	5	00	01	10	11																																																																																																																						
	Bit13	Bit12	6	00	01	10	11																																																																																																																						
	Bit15	Bit14	7	00	01	10	11																																																																																																																						
P10.35	Bit1	Bit0	8	00	01	10	11																																																																																																																						
	Bit3	Bit2	9	00	01	10	11																																																																																																																						
	Bit5	Bit4	10	00	01	10	11																																																																																																																						
	Bit7	Bit6	11	00	01	10	11																																																																																																																						
	Bit9	Bit8	12	00	01	10	11																																																																																																																						
	Bit11	Bit10	13	00	01	10	11																																																																																																																						
	Bit13	Bit12	14	00	01	10	11																																																																																																																						
	Bit15	Bit14	15	00	01	10	11																																																																																																																						

Function code	Name	Description	Default	Modify
		P08.05. Setting range: 0x0000–0xFFFF		
P10.36	PLC restart mode	0: Restart from multi-step speed 0. Restart from the first step, namely if the VFD stops during running (caused by stop command, fault or power down), it will run from the first step after restart. 1: Resume from the paused step. If the VFD stops during running (caused by stop command or fault), it records the running time of current step. It enters this step automatically after restart, and then continues running at the frequency defined by this step in the remaining time.	0	☉
P10.37	Multi-step time unit	0: second; the running time of each step is counted in seconds 1: minute; the running time of each step is counted in minutes	0	☉
P10.38	Multi-step speed ACC/DEC time selection	0–1 0:P00.11 and P00.12 1:According to P10.34 and P10.35	0	☉

Group P11—Protection parameters

Function code	Name	Description	Default	Modify
P11.00	Protection against phase loss	0x000–0x111 Ones place: 0: Disable software input phase loss protection. 1: Enable software input phase loss protection. Tens place: 0: Output phase loss protection disabled 1: Protection against output phrase loss enabled Hundreds place: Reserved	0x011	○
P11.01	Frequency drop at transient power-off	0: Disable 1: Enable If the bus voltage drops to the sudden	0	○

Function code	Name	Description	Default	Modify								
		<p>frequency decreasing point due to power failure, the VFD decreases the running frequency by using the constant bus voltage control method, which makes the motor in power generation state. The regenerative power can maintain the bus voltage to ensure normal running of the VFD until the recovery of power.</p> <table border="1"> <tr> <td>Voltage class</td> <td>220V</td> <td>380V</td> <td>660V</td> </tr> <tr> <td>Frequency decrease at sudden power failure</td> <td>260V</td> <td>460V</td> <td>800V</td> </tr> </table> <p>Note:</p> <ul style="list-style-type: none"> ✧ This function can avoid VFD stop that is made for the purpose of protection in grid switchover. ✧ This function can be enabled only when the input phase loss protection function is disabled. 	Voltage class	220V	380V	660V	Frequency decrease at sudden power failure	260V	460V	800V		
Voltage class	220V	380V	660V									
Frequency decrease at sudden power failure	260V	460V	800V									
P11.02	Reserved	-	-	-								
P11.03	Overvoltage stall protection	<p>0: Disable 1: Enable</p> <p>If the bus voltage exceeds the overvoltage stalling point, the motor is in power generation state, and the overvoltage stalling protection function takes effect to regulate output frequency (that is, consume unnecessary regenerative electricity).</p>	1	○								
P11.04	Overvoltage stalling protection voltage	380V: 120–150% (relative to standard bus voltage)	136%	○								
		220V: 120–150% (relative to standard bus voltage)	120%									

Function code	Name	Description	Default	Modify
		voltage)		
P11.05	Current limit mode	<p>During accelerated running, as the load is too large, the actual acceleration rate of motor is lower than that of output frequency, if no measures are taken, the VFD may trip due to overcurrent during acceleration.</p> <p>0x00–0x11</p> <p>Ones place: Current limit action</p> <p>0: Invalid</p> <p>1: Always valid</p> <p>Tens place: Hardware current limit overload alarm</p> <p>0: Valid</p> <p>1: Invalid</p>	0x01	☉
P11.06	Automatic current limit threshold	The current-limit protection function detects output current during running, and compares it with the current-limit level specified by P11.06. If it exceeds the current-limit level, the VFD will run at stable frequency during accelerated running, or the VFD will run at decreased frequency during constant-speed running; if it exceeds the current-limit level continuously, the VFD output frequency will drop continuously until reaching the lower limit frequency. When the output current is detected to be lower than the current-limit level again, it will continue accelerated running.	Model depended	☉
P11.07	Frequency drop rate during current limit	<p>Setting range of P11.06: 50.0–200.0% (default value for G-type machine: 160.0%,</p>	10.00 Hz/s	☉

Function code	Name	Description	Default	Modify
		default value for P-type machine: 120.0%) Setting range of P11.07: 0.00–50.00Hz/s		
P11.08	VFD/motor OL/UL alarm selection	0x000–0x1134 Ones place: 0:Motor OL/UL pre-alarm. The overload is relative to the motor's rated current, while the underload is also relative to the motor's rated current. 1:VFD OL/UL pre-alarm. The overload is relative to the VFD's rated current, while the underload is relative to the motor's rated current. 2:Motor output torque OL/UL pre-alarm. relative to the motor rated current. The overload is relative to the motor's rated torque, while the underload is relative to the motor's rated torque. 3: Motor OL/UL pre-alarm. The overload is relative to the motor rated current; while the underload is relative to the motor rated power. 4: VFD OL/UL pre-alarm. The overload is relative to the VFD rated current; while the underload is relative to the VFD rated power. Tens place: 0: The VFD continues to work for an OL/UL alarm. 1: The VFD continues to work for a UL alarm but stops running for an OL fault 2: The VFD continues to work for an OL alarm but stops running for a UL fault 3. The VFD stops running for an OL/UL alarm Hundreds place: 0: Detect all the time. 1: Detect during constant speed running. Thousands place: VFD overload current reference selection 0: Related to current calibration coefficient	0x0000	○

Function code	Name	Description	Default	Modify
		1: Irrelated to current calibration coefficient		
P11.09	Overload pre-alarm detection threshold	If the VFD or motor output current is larger than the overload pre-alarm detection level (P11.09), and the duration exceeds the overload pre-alarm detection time (P11.10), overload pre-alarm signal will be outputted.	Model depended	<input type="radio"/>
P11.10	Overload pre-alarm detection time	<p>Setting range of P11.09: P11.11–200.0% (default value for G-type machine: 150%, default value for P-type machine: 120%) P11.10 setting range: 0.1–3600.0s</p>	1.0s	<input type="radio"/>
P11.11	Underload pre-alarm detection threshold	Underload pre-alarm signal will be outputted if the output current of the VFD or motor is lower than underload pre-alarm detection level (P11.11), and the duration exceeds underload pre-alarm detection time (P11.12).	50%	<input type="radio"/>
P11.12	Underload pre-alarm detection time	Setting range of P11.11: 0%–P11.09 Setting range of P11.12: 0.1–3600.0s	1.0s	<input type="radio"/>
P11.13	Fault output terminal action upon fault occurring	Used to set the action of fault output terminals at undervoltage and fault reset. 0x00–0x11 Ones place: 0: Act at undervoltage 1: Do not act at undervoltage Tens place: 0: Act during automatic reset period 1: Do not act during the automatic reset period	0x00	<input type="radio"/>
P11.14	Speed deviation	0.0–50.0%	10.0%	<input type="radio"/>

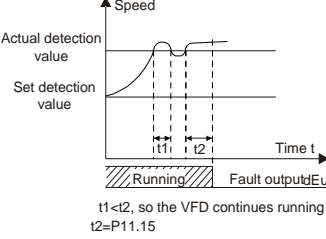
Function code	Name	Description	Default	Modify
	detection value	Used to set the speed deviation detection value.		
P11.15	Speed deviation detection time	<p>0.0–10.0s</p> <p>Note: Speed deviation protection is invalid when P11.15=0.0.</p>  <p>t1 < t2, so the VFD continues running t2 = P11.15</p>	2.0s	<input type="radio"/>
P11.16	Automatic frequency-reduction during voltage drop	<p>0–1</p> <p>0: Invalid 1: Valid</p>	0	<input type="radio"/>
P11.17	Proportional coefficient of voltage regulator during undervoltage stall	<p>This parameter is used to set the proportional coefficient of the bus voltage regulator during undervoltage stall.</p> <p>Setting range: 0–1000</p>	100	<input type="radio"/>
P11.18	Integral coefficient of voltage regulator during undervoltage stall	<p>This parameter is used to set the integral coefficient of the bus voltage regulator during undervoltage stall.</p> <p>Setting range: 0–1000</p>	40	<input type="radio"/>
P11.19	Proportional coefficient of current regulator during undervoltage stall	<p>This parameter is used to set the proportional coefficient of the active current regulator during undervoltage stall.</p> <p>Setting range: 0–1000</p>	25	<input type="radio"/>
P11.20	Integral coefficient of current regulator during undervoltage stall	<p>This parameter is used to set the integral coefficient of the active current regulator during undervoltage stall.</p> <p>Setting range: 0–2000</p>	150	<input type="radio"/>
P11.21	Proportional coefficient of voltage regulator during overvoltage	<p>This parameter is used to set the proportional coefficient of the bus voltage regulator during overvoltage stall.</p> <p>Setting range: 0–1000</p>	60	<input type="radio"/>

Function code	Name	Description	Default	Modify
	stall			
P11.22	Integral coefficient of voltage regulator during overvoltage stall	This parameter is used to set the integral coefficient of the bus voltage regulator during overvoltage stall. Setting range: 0–1000	10	<input type="radio"/>
P11.23	Proportional coefficient of current regulator during overvoltage stall	This parameter is used to set the proportional coefficient of the active current regulator during overvoltage stall. Setting range: 0–1000	60	<input type="radio"/>
P11.24	Integral coefficient of current regulator during overvoltage stall	This parameter is used to set the integral coefficient of the active current regulator during overvoltage stall. Setting range: 0–2000	250	<input type="radio"/>
P11.25	Enabling VFD overload integral	0: Disable 1: Enable When this parameter is set to 0, the overload timing value is reset to zero after the VFD is stopped. In this case, the determination of VFD overload takes more time, and therefore the effective protection over the VFD is weakened. When this parameter is set to 1, the overload timing value is not reset, and the overload timing value is accumulative. In this case, the determination of VFD overload takes less time, and therefore the protection over the VFD can be performed more quickly.	1	<input checked="" type="radio"/>
P11.26	Reserved	-	-	-
P11.27	VF oscillation control method	0x00–0x11 Ones place: 0: Method 1 1: Method 2 Tens place: Reserved	0x11	<input checked="" type="radio"/>
P11.28	Software input phase loss detection method	0–1 0: Sine-wave detection 1: Square-wave detection Note: Since phase loss detection is implemented through software, output phase loss cannot be detected when the VFD is running without a motor, and input phase loss	1	<input type="radio"/>

Function code	Name	Description	Default	Modify
		cannot be detected during no-load or light-load operation. Input phase loss can only be detected normally when the load current is above 60% of the rated current.		
P11.29	Software input phase loss detection limit value	0–200.0V Note: Larger values are less likely to report a fault.	40.0V	○
P11.30	Software input phase loss detection time	0–20.0s Note: Larger values are less likely to report a fault.	2.0s	○
P11.31	Fault severity group 1	0x0000–0x3313 Ones place (fault 11=OL1): 0: Report a fault 1: Report a fault after deceleration to stop 2: Pre-alarm, with the action executed according to P11.51 3: Screen out fault Tens place (fault 12=OL2): 0: Report a fault 1: Report a fault after deceleration to stop Hundreds place (fault 13=SPI): 0: Report a fault 1: Report a fault after deceleration to stop 2: Pre-alarm, with the action executed according to P11.51 3: Screen out fault Thousands place (fault 14=SPO): 0: Report a fault 1: Report a fault after deceleration to stop 2: Pre-alarm, with the action executed according to P11.51 3: Screen out fault Note: Different fault actions are taken for different fault severities. The first 10 faults are not grouped by severity, but each four of the subsequent faults are grouped by severity in ascending order from right to left in hexadecimal format.	0x0000	○

Function code	Name	Description	Default	Modify
		Group 1: Fault 11–14 Group 2: Fault 15–18 Group 3: Fault 19–22 Group 4: Fault 23–26 Group 5: Fault 27–30 Group 6: Fault 31–34 Group 7: Fault 35–38 Group 8: Fault 39–42 Group 9: Fault 43–46 Group 10: Fault 47–50 Group 11: Fault 51–54 Group 12: Fault 55–58 Group 13: Fault 59–62 Group 14: Fault 63–66 Group 15: Fault 67–70 Group 16: Fault 71–75 Group 17: Fault 75–78 Group 18: Fault 79–82 Group 19: Fault 83–86 Group 20: Fault 87–90		
P11.32	Fault severity group 2	0x0000–0x3300 Ones place(fault 15=OH1): 0: Report a fault Tens place(fault 16=OH2): 0: Report a fault Hundreds place(fault 17=EF): 0: Report a fault 1: Report a fault after deceleration to stop 2: Pre-alarm, with the action executed according to P11.51 3: Screen out fault Thousands place(fault 18=CE): 0: Report a fault 1: Report a fault after deceleration to stop 2: Pre-alarm, with the action executed according to P11.51 3: Screen out fault	0x0000	○
P11.33	Fault severity group	0x0000–0x3000	0x0000	○

Function code	Name	Description	Default	Modify
	3	Ones place (fault 19=ItE): 0: Report a fault Tens place (fault 20=tE): 0: Report a fault Hundreds place (fault 21=EEP): 0: Report a fault Thousands place (fault 22=PIDE): 0: Report a fault 1: Report a fault after deceleration to stop 2: Pre-alarm, with the action executed according to P11.51 3: Screen out fault		
P11.34	Fault severity group 4	0x0000–0x3301 Ones place (fault 23=bCE): 0: Report a fault 1: Report a fault after deceleration to stop Hundreds place (fault 24=END): 0: Report a fault Hundreds place (fault 25=OL3): 0: Report a fault 1: Report a fault after deceleration to stop 2: Pre-alarm, with the action executed according to P11.51 3: Screen out fault Thousands place (fault 26=PCE): 0: Report a fault 1: Report a fault after deceleration to stop 2: Pre-alarm, with the action executed according to P11.51 3: Screen out fault	0x0000	○
P11.35	Fault severity group 5	0x0000–0x0300 Ones place (fault 27=UPE): 0: Report a fault Hundreds place (fault 28=DNE): 0: Report a fault Hundreds place (fault 29=E-DP): 0: Report a fault 1: Report a fault after deceleration to stop	0x0000	○

Function code	Name	Description	Default	Modify
		2: Pre-alarm, with the action executed according to P11.51 3: Screen out fault Thousands place (fault 30=Reserved): 0: Reserved		
P11.36	Fault severity group 6	0x0000–0x3003 Ones place (fault 31=E-CAN): 0: Report a fault 1: Report a fault after deceleration to stop 2: Pre-alarm, with the action executed according to P11.51 3: Screen out fault Tens place (fault 32=ETH1): 0: Report a fault Hundreds place (fault 33=ETH2): 0: Report a fault Thousands place (fault 34=dEu): 0: Report a fault 1: Report a fault after deceleration to stop 2: Pre-alarm, with the action executed according to P11.51 3: Screen out fault	0x0000	○
P11.37	Fault severity group 7	0x0000–0x0011 Ones place (fault 35= STo): 0: Report a fault 1: Report a fault after deceleration to stop Hundreds place (fault 36=LL): 0: Report a fault 1: Report a fault after deceleration to stop Hundreds place (fault 37=Reserved): Thousands place (fault 38=Reserved):	0x0000	○
P11.38	Fault severity group 8	0x0000–0x0000 Ones place (fault 39=Reserved): Tens place (fault 40=Reserved): Hundreds place (fault 41=Reserved): Thousands place (fault 42=Reserved):		
P11.39	Fault severity group 9	0x0000–0x0000 Ones place (fault 43=Reserved):		

Function code	Name	Description	Default	Modify
		Tens place (fault 44=Reserved): Hundreds place (fault 45=Reserved): Thousands place (fault 46=Reserved):		
P11.40	Fault severity group 10	0x0000–0x0000 Ones place (fault 47=Reserved): Tens place (fault 48=Reserved): Hundreds place (fault 49=Reserved): Thousands place (fault 50=Reserved):		
P11.41	Fault severity group 11	0x0000–0x0000 Ones place (fault 51=Reserved): Tens place (fault 52=Reserved): Hundreds place (fault 53=Reserved): Thousands place (fault 54=Reserved):		
P11.42	Fault severity group 12	0x0000–0x3303 Ones place (fault 55=E-Err): 0: Report a fault 1: Report a fault after deceleration to stop 2: Pre-alarm, with the action executed according to P11.51 3: Screen out fault Tens place (fault 56=Reserved): Hundreds place (fault 57=E-PN): 0: Report a fault 1: Report a fault after deceleration to stop 2: Pre-alarm, with the action executed according to P11.51 3: Screen out fault Thousands place (fault 58=SECAN): 0: Report a fault 1: Report a fault after deceleration to stop 2: Pre-alarm, with the action executed according to P11.51 3: Screen out fault	0x0000	○
P11.43	Fault severity group 13	0x0000–0x0333 Ones place(fault 59=OT): 0: Report a fault 1: Report a fault after deceleration to stop 2: Pre-alarm, with the action executed	0x0000	○

Function code	Name	Description	Default	Modify
		according to P11.51 3: Screen out fault Tens place (fault 60=F1-Er): 0: Report a fault 1: Report a fault after deceleration to stop 2: Pre-alarm, with the action executed according to P11.51 3: Screen out fault Hundreds place (fault 61=F2-Er): 0: Report a fault 1: Report a fault after deceleration to stop 2: Pre-alarm, with the action executed according to P11.51 3: Screen out fault Thousands place (fault 62=Reserved):		
P11.44	Fault severity group 14	0x0000–0x0033 Ones place (fault 63=C1-Er): 0: Report a fault 1: Report a fault after deceleration to stop 2: Pre-alarm, with the action executed according to P11.51 3: Screen out fault Tens place (fault 64=C2-Er): 0: Report a fault 1: Report a fault after deceleration to stop 2: Pre-alarm, with the action executed according to P11.51 3: Screen out fault Hundreds place (fault 65=Reserved): Thousands place (fault 66=Reserved):	0x0000	○
P11.45	Fault severity group 15	0x0000–0x0300 Ones place (fault 67=Reserved): Tens place (fault 68=Reserved): Hundreds place (fault 69= S-Err): 0: Report a fault 1: Report a fault after deceleration to stop 2: Pre-alarm, with the action executed according to P11.51	0x0000	○

Function code	Name	Description	Default	Modify
		3: Screen out fault Thousands place (fault 70=Reserved):		
P11.46	Fault severity group 16	0x0000–0x3300 Ones place (fault 71=Reserved): Tens place (fault 72=Reserved): Hundreds place (fault 73=Freezing fault): 0: Report a fault 1: Report a fault after deceleration to stop 2: Pre-alarm, with the action executed according to P11.51 3: Screen out fault Thousands place (fault 74=Stalling): 0: Report a fault 1: Report a fault after deceleration to stop 2: Pre-alarm, with the action executed according to P11.51 3: Screen out fault	0x0000	○
P11.47	Fault severity group 17	0x0000–0x3333 Ones place (fault 75=Dry pumping): 0: Report a fault 1: Report a fault after deceleration to stop 2: Pre-alarm, with the action executed according to P11.51 3: Screen out fault Tens place (fault 76=A11 disconnection): 0: Report a fault 1: Report a fault after deceleration to stop 2: Pre-alarm, with the action executed according to P11.51 3: Screen out fault Tens (fault 77=A12 disconnection) 0: Report a fault 1: Report a fault after deceleration to stop 2: Pre-alarm, with the action executed according to P11.51 3: Screen out fault Thousands (fault 78=A13 disconnection) 0: Report a fault	0x0000	○

Function code	Name	Description	Default	Modify
		1: Report a fault after deceleration to stop 2: Pre-alarm, with the action executed according to P11.51 3: Screen out fault		
P11.48	Fault severity group 18	0x0000–0x0003 Ones place (fault 79=Water pipe breaking): 0: Report a fault 1: Report a fault after deceleration to stop 2: Pre-alarm, with the action executed according to P11.51 3: Screen out fault Tens place (fault 80=Reserved): 0: Report a fault Hundreds place (fault 81=Reserved): 0: Reserved Thousands place (fault 82=Reserved): 0: Report a fault	0x0000	○
P11.49	Fault severity group 19	0x0000–0x0000 Ones place (fault 83=Reserved): Tens place (fault 84=Reserved): Hundreds place (fault 85=Reserved): Thousands place (fault 86=Reserved):	0x0000	○
P11.50	Fault severity group 20	0x0000–0x0000 Ones place (fault 87=Reserved): Tens place (fault 88=Reserved): Hundreds place (fault 89=Reserved): Thousands place (fault 90=Reserved):	0x0000	○
P11.51	Action for fault pre-alarm	0–4 0: Run at the set frequency 1: Run at the output frequency at the time of failure 2: Run at the upper limit frequency 3: Run at the lower limit frequency 4: Run at the backup frequency upon exceptions	0x0000	○
P11.52	Backup frequency upon exceptions	0.00Hz–P00.03 (Max. output frequency)	0.00Hz	○

Group P12—Parameters of motor 2

Function code	Name	Description	Default	Modify
P12.00	Type of motor 2	0: Asynchronous motor (AM) 1: Synchronous motor (SM)	0	<input checked="" type="radio"/>
P12.01	Rated power of AM 2	0.1–3000.0kW	Model depended (0.4)	<input checked="" type="radio"/>
P12.02	Rated frequency of AM 2	0.01Hz–P00.03 (Max. output frequency)	50.00Hz	<input checked="" type="radio"/>
P12.03	Rated speed of AM 2	1–60000rpm	Model depended (1400)	<input checked="" type="radio"/>
P12.04	Rated voltage of AM 2	0–1200V	Model depended (380)	<input checked="" type="radio"/>
P12.05	Rated current of AM 2	0.8–6000.0A	Model depended (1.0)	<input checked="" type="radio"/>
P12.06	Stator resistance of AM 2	0.001–65.535Ω	Model depended (0.001)	<input type="radio"/>
P12.07	Rotor resistance of AM 2	0.001–65.535Ω	Model depended (0.001)	<input type="radio"/>
P12.08	Leakage inductance of AM 2	0.1–6553.5mH	Model depended (0.1)	<input type="radio"/>
P12.09	Mutual inductance of AM 2	0.1–6553.5mH	Model depended (0.1)	<input type="radio"/>
P12.10	No-load current of AM 2	0.1–6553.5A	Model depended (0.1)	<input type="radio"/>
P12.11	Magnetic saturation coefficient 1 of iron core of AM 2	0.0–100.0%	80%	<input type="radio"/>
P12.12	Magnetic saturation coefficient 2 of iron core of AM 2	0.0–100.0%	68%	<input type="radio"/>

Function code	Name	Description	Default	Modify
P12.13	Magnetic saturation coefficient 3 of iron core of AM 2	0.0–100.0%	57%	<input type="radio"/>
P12.14	Magnetic saturation coefficient 4 of iron core of AM 2	0.0–100.0%	40%	<input type="radio"/>
P12.15	Rated power of SM 2	0.1–3000.0kW	Model depended (0.4)	<input checked="" type="radio"/>
P12.16	Rated frequency of SM 2	0.01Hz–P00.03 (Max. output frequency)	50.00Hz	<input checked="" type="radio"/>
P12.17	Number of pole pairs of SM 2	1–128	2	<input checked="" type="radio"/>
P12.18	Rated voltage of SM 2	0–1200V	Model depended (380)	<input checked="" type="radio"/>
P12.19	Rated current of SM 2	0.8–6000.0A	Model depended (1.0)	<input checked="" type="radio"/>
P12.20	Stator resistance of SM 2	0.001–65.535Ω	Model depended (0.001)	<input type="radio"/>
P12.21	Direct-axis inductance of SM 2	0.01–655.35mH	Model depended (0.01)	<input type="radio"/>
P12.22	Quadrature-axis inductance of SM 2	0.01–655.35mH	Model depended (0.01)	<input type="radio"/>
P12.23	Counter-emf constant of SM 2	0–10000V	300	<input type="radio"/>
P12.24	Initial pole position of SM 2	0x0000–0xFFFF	0x0000	<input checked="" type="radio"/>
P12.25	Identification current of SM 2	0–50% (of the motor rated current)	10%	<input checked="" type="radio"/>
P12.26	Overload protection selection of motor 2	0: No protection 1: Common motor (with low-speed compensation) 2: Frequency-variable motor (without	2	<input checked="" type="radio"/>

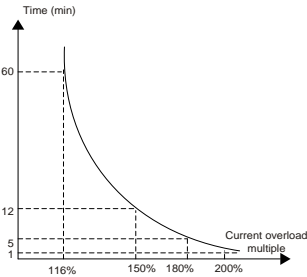
Function code	Name	Description	Default	Modify
		low-speed compensation)		
P12.27	Overload protection coefficient of motor 2	<p>Motor overload multiples $M = I_{out} / (I_n * K)$</p> <p>I_n indicates the rated motor current, I_{out} indicates the VFD output current, and K indicates the motor overload protection coefficient.</p> <p>A smaller value of "K" indicates a bigger value of "M".</p> <p>When $M=116\%$, protection is performed after motor overload lasts for 1 hour; when $M=200\%$, protection is performed after motor overload lasts for 60 seconds; and when $M \geq 400\%$, protection is performed immediately.</p>  <p>Setting range: 20.0%–150.0%</p>	100.0%	<input type="radio"/>
P12.28	Power display calibration coefficient of motor 2	0.00–3.00	1.00	<input type="radio"/>
P12.29	Parameter display of motor 2	<p>0: Display by motor type</p> <p>In this mode, only parameters related to the present motor type are displayed.</p> <p>1: Display all</p> <p>In this mode, all the motor parameters are displayed.</p>	0	<input type="radio"/>
P12.30	System inertia of motor 2	0.000–30.000kg·m ²	0.000 kg·m ²	<input type="radio"/>

Group P13—SM control

Function code	Name	Description	Default	Modify
P13.00	SM injected-current decrease ratio	Used to set the reduction rate of the input reactive current. When the active current of the synchronous motor increases to some extent, the input reactive current can be reduced to improve the power factor of the motor. Setting range: 0.0%~+100.0% (of the motor rated current)	80.0%	<input type="radio"/>
P13.01	Detection mode of initial pole	0-2 0: Do not detect 1: High-frequency superposition 2: Pulse superposition	0	<input checked="" type="radio"/>
P13.02	Pull-in current 1	Pull-in current is the pole position orientation current; pull-in current 1 is valid within the lower limit of pull-in current switch-over frequency threshold. If you need to increase the start torque, increase the value of this function parameter properly. Setting range: -100.0%~100.0% (of the motor rated current)	20.0%	<input type="radio"/>
P13.03	Pull-in current 2	Pull-in current is the pole position orientation current; pull-in current 2 is valid within the lower limit of pull-in current switch-over frequency threshold. You do not need to change the value in most cases. Setting range: -100.0%~100.0% (of the motor rated current)	10.0%	<input type="radio"/>
P13.04	Pull-in current switchover frequency	0.00Hz~P00.03 (Max. output frequency)	10.00Hz	<input type="radio"/>
P13.05	High frequency superimposed frequency	200~1000Hz	500Hz	<input checked="" type="radio"/>
P13.06	High-frequency superposition voltage	Used to set the pulse current threshold when the initial magnetic pole position is detected in the pulse mode, The value is a percentage in relative to the rated current of the motor.	100.0%	<input checked="" type="radio"/>

Function code	Name	Description	Default	Modify
		Setting range: 0.0–300.0% (of the motor rated voltage)		
P13.07	Control parameter 0	0.0–400.0	0.0	<input type="radio"/>
P13.08	Control parameter 1	0x0000–0xFFFF	0x0000	<input type="radio"/>
P13.09	Control parameter 2	Used to set the frequency threshold for enabling the counter-electromotive force phase-locked loop in SVC 0. When the running frequency is lower than the value of the function code, the phase-locked loop is disabled; and when the running frequency is higher than that, the phase-locked loop is enabled. Setting range: 0–655.35	2.00	<input type="radio"/>
P13.10	Initial compensation angle of SM	0.0–359.9°	0.0°	<input type="radio"/>
P13.11	Mal-adjustment detection time	Used to adjust the responsiveness of anti-maladjustment function. If the load inertia is large, increase the value of this parameter properly, however, the responsiveness may slow down accordingly. Setting range: 0.0–10.0s	0.5s	<input type="radio"/>
P13.12	High-frequency compensation coefficient of SM	Valid when the motor speed exceeds the rated speed. If oscillation occurred to the motor, adjust this parameter properly. Setting range: 0.0–100.0%	0.0%	<input type="radio"/>
P13.13	High-frequency pull-in current	0.0–300.0% (of the VFD rated output current)	20.0%	<input checked="" type="radio"/>

Group P14—Serial communication

Function code	Name	Description	Default	Modify
P14.00	Local communication address	Setting range: 1–247 When the master writes the slave communication address to 0 indicating a broadcast address in a frame, all the slaves	1	<input type="radio"/>

Function code	Name	Description	Default	Modify
		on the Modbus bus receive the frame but do not respond to it. The communication addresses on the communication network are unique, which is the basis of the point-to-point communication. Note: The slave address cannot be set to 0.		
P14.01	Communication baud rate setting	Used to set the rate of data transmission between the host controller and the VFD. 0: 1200bps 1: 2400 bps 2: 4800 bps 3: 9600 bps 4: 19200 bps 5: 38400 bps 6: 57600 bps 7: 115200 bps Note: The baud rate set on the VFD must be consistent with that on the host controller. Otherwise, the communication fails. A greater baud rate indicates faster communication.	4	○
P14.02	Data bit check	The data format set on the VFD must be consistent with that on the host controller. Otherwise, the communication fails. 0: No check (N, 8, 1) for RTU 1: Even check (E, 8, 1) for RTU 2: Odd check (O, 8, 1) for RTU 3: No check (N, 8, 2) for RTU 4: Even check (E, 8, 2) for RTU 5: Odd check (O, 8, 2) for RTU	1	○
P14.03	Communication response delay	0–200ms Indicates the communication response delay, that is, the interval from when the VFD completes receiving data to when it sends response data to the host controller. If the response delay is shorter than the rectifier processing time, the rectifier sends response data to the host controller after processing data. If the delay is longer than the rectifier	5ms	○

Function code	Name	Description	Default	Modify
		processing time, the rectifier does not send response data to the host controller until the delay is reached although data has been processed.		
P14.04	Communication timeout time	0.0 (invalid); 0.1–60.0s When the function code is set to 0.0, the communication timeout time is invalid. When the function code is set to a non-zero value, the system reports the "485 communication fault" (CE) if the communication interval exceeds the value. In general, the function code is set to 0.0. When continuous communication is required, you can set the function code to monitor communication status.	0.0s	<input type="radio"/>
P14.05	Transmission fault processing	0–3 0: Report an alarm and coast to stop 1: Keep running without reporting an alarm 2: Stop in enabled stop mode without reporting an alarm (applicable only to communication mode) 3: Stop in enabled stop mode without reporting an alarm (applicable to any mode)	0	<input type="radio"/>
P14.06	Communication processing action	0x000–0x111 Ones place: 0: Respond to write operations 1: Not respond to write operations Tens place: 0: Communication password protection is invalid. 1: Communication password protection is valid. Hundreds place: 0: Custom addresses of P14.07, P14.08 are invalid. 1: Custom addresses of P14.07, P14.08 are valid.	0x000	<input type="radio"/>
P14.07	User-defined	0x0000–0xFFFF	0x2000	<input type="radio"/>

Function code	Name	Description	Default	Modify
	running command address			
P14.08	User-defined frequency setting address	0x0000–0xFFFF	0x2001	<input type="radio"/>
P14.09	Modbus TCP communication timeout time	0.0–60.0s	5.0s	<input type="radio"/>
P14.10	Enabling 485 upgrade program	0–1 0: Disable 1: Enable	0	<input checked="" type="radio"/>
P14.11	Bootload software version	0.00–655.35	0.00	<input checked="" type="radio"/>
P14.12–P14.18	Reserved	-	-	-
P14.19	Address mapping function control	0x00–0x11 Ones place: Read address mapping function 0: Invalid 1: Enabled Tens place: Write address mapping function 0: Invalid 1: Enabled	0x00	<input type="radio"/>
P14.20	2200H read mapped address	0x0000–0xFFFF Used to set the register address mapped to 2200H.	0x0000	<input type="radio"/>
P14.21	2201H read mapped address	0x0000–0xFFFF Used to set the register address mapped to 2201H.	0x0000	<input type="radio"/>
P14.22	2202H read mapped address	0x0000–0xFFFF Used to set the register address mapped to 2202H.	0x0000	<input type="radio"/>
P14.23	2203H read mapped address	0x0000–0xFFFF Used to set the register address mapped to 2203H.	0x0000	<input type="radio"/>
P14.24	2204H read mapped address	0x0000–0xFFFF Used to set the register address mapped to 2204H.	0x0000	<input type="radio"/>
P14.25	2205H read	0x0000–0xFFFF	0x0000	<input type="radio"/>

Function code	Name	Description	Default	Modify
	mapped address	Used to set the register address mapped to 2205H.		
P14.26	2206H read mapped address	0x0000–0xFFFF Used to set the register address mapped to 2206H.	0x0000	<input type="radio"/>
P14.27	2207H read mapped address	0x0000–0xFFFF Used to set the register address mapped to 2207H.	0x0000	<input type="radio"/>
P14.28	2208H read mapped address	0x0000–0xFFFF Used to set the register address mapped to 2208H.	0x0000	<input type="radio"/>
P14.29	2209H read mapped address	0x0000–0xFFFF Used to set the register address mapped to 2209H.	0x0000	<input type="radio"/>
P14.30	220AH read mapped address	0x0000–0xFFFF Used to set the register address mapped to 220AH.	0x0000	<input type="radio"/>
P14.31	220BH read mapped address	0x0000–0xFFFF Used to set the register address mapped to 220BH.	0x0000	<input type="radio"/>
P14.32	2300H write mapped address	0x0000–0xFFFF Used to set the register address mapped to 2300H.	0x0000	<input type="radio"/>
P14.33	2301H write mapped address	0x0000–0xFFFF Used to set the register address mapped to 2301H.	0x0000	<input type="radio"/>
P14.34	2302H write mapped address	0x0000–0xFFFF Used to set the register address mapped to 2302H.	0x0000	<input type="radio"/>
P14.35	2303H write mapped address	0x0000–0xFFFF Used to set the register address mapped to 2303H.	0x0000	<input type="radio"/>
P14.36	2304H write mapped address	0x0000–0xFFFF Used to set the register address mapped to 2304H.	0x0000	<input type="radio"/>
P14.37	2305H write mapped address	0x0000–0xFFFF Used to set the register address mapped to 2305H.	0x0000	<input type="radio"/>

Function code	Name	Description	Default	Modify
P14.38	2306H write mapped address	0x0000–0xFFFF Used to set the register address mapped to 2306H.	0x0000	<input type="radio"/>
P14.39	2307H write mapped address	0x0000–0xFFFF Used to set the register address mapped to 2307H.	0x0000	<input type="radio"/>
P14.40	2308H write mapped address	0x0000–0xFFFF Used to set the register address mapped to 2308H.	0x0000	<input type="radio"/>
P14.41	2309H write mapped address	0x0000–0xFFFF Used to set the register address mapped to 2309H.	0x0000	<input type="radio"/>
P14.42	230AH write mapped address	0x0000–0xFFFF Used to set the register address mapped to 230AH.	0x0000	<input type="radio"/>
P14.43	230BH write mapped address	0x0000–0xFFFF Used to set the register address mapped to 230BH.	0x0000	<input type="radio"/>

Group P15—Communication expansion card 1 functions

Function code	Name	Description	Default	Modify
P15.00	Reserved	0–4	0	<input checked="" type="radio"/>
P15.01	Module address	0–127	2	<input type="radio"/>
P15.02	Received PZD2	0–31	0	<input type="radio"/>
P15.03	Received PZD3	0: Invalid	0	<input type="radio"/>
P15.04	Received PZD4	1: Set frequency (0–Fmax, unit: 0.01Hz)	0	<input type="radio"/>
P15.05	Received PZD5	2: PID reference (-1000–1000, in which 1000 corresponds to 100.0%)	0	<input type="radio"/>
P15.06	Received PZD6		0	<input type="radio"/>
P15.07	Received PZD7	3: PID feedback (-1000–1000, in which 1000 corresponds to 100.0%)	0	<input type="radio"/>
P15.08	Received PZD8		0	<input type="radio"/>
P15.09	Received PZD9	4: Torque setting (-3000–+3000, in which 1000 corresponds to 100.0% of the motor rated current)	0	<input type="radio"/>
P15.10	Received PZD10		0	<input type="radio"/>
P15.11	Received PZD11		0	<input type="radio"/>
P15.12	Received PZD12	5: Setting of the upper limit of forward running frequency (0–Fmax, unit: 0.01Hz) 6: Setting of the upper limit of reverse running frequency (0–Fmax, unit: 0.01Hz)	0	<input type="radio"/>

Function code	Name	Description	Default	Modify
		7: Upper limit of the electromotive torque (0–3000, in which 1000 corresponds to 100.0% of the motor rated current) 8: Upper limit of braking torque (0–3000, in which 1000 corresponds to 100% of the motor rated current) 9: Virtual input terminal command. Range: 0x000–0x3FF 10: Virtual output terminal command. Range: 0x00–0x0F 11: Voltage setting (special for V/F separation) (0–1000, in which 1000 corresponds to 100% of the motor rated voltage) 12: AO1 output setting 1 (-1000–+1000, in which 1000 corresponds to 100.0%) 13: AO2 output setting 2 (-1000–+1000, in which 1000 corresponds to 100.0%) 14–18: Reserved 19: PID1 reference source 1 (0–1000, in which 1000 corresponds to 100.0%) 20: PID1 feedback source 1 (0–1000, in which 1000 corresponds to 100.0%) 21: PID1 reference source 2 (0–1000, in which 1000 corresponds to 100.0%) 22: PID1 feedback source 2 (0–1000, in which 1000 corresponds to 100.0%) 23: PID2 reference source (0–1000, in which 1000 corresponds to 100.0%) 24: PID2 feedback source (0–1000, in which 1000 corresponds to 100.0%) 25: Inlet water level (0–1000, in which 1000 corresponds to 100.0%) 26: AOO output setting 0 (-1000–+1000, in which 1000 corresponds to 100.0%) 27–31: Reserved		
P15.13	Sent PZD2	0–37	0	<input type="radio"/>
P15.14	Sent PZD3	0: Invalid	0	<input type="radio"/>

Function code	Name	Description	Default	Modify
P15.15	Sent PZD4	1: Running frequency (×100, Hz)	0	○
P15.16	Sent PZD5	2: Set frequency (×100, Hz)	0	○
P15.17	Sent PZD6	3: Bus voltage (×10, V)	0	○
P15.18	Sent PZD7	4: Output voltage (×1, V)	0	○
P15.19	Sent PZD8	5: Output current (×10, A)	0	○
P15.20	Sent PZD9	6: Actual output torque (×10, %)	0	○
P15.21	Sent PZD10	7: Actual output power (×10, %)	0	○
P15.22	Sent PZD11	8: Rotation speed of running (×1, RPM)	0	○
P15.23	Sent PZD12	9: Linear speed of running (×1, m/s)	0	○
		10: Ramp reference frequency		
		11: Fault code		
		12: AI1 input (×100, V)		
		13: AI2 input (×100, V)		
		14: AI3 input (×100, V)		
		15: HDIA frequency value (×1000, kHz)		
		16: Terminal input status		
		17: Terminal output status		
		18: PID reference (×100, %)		
		19: PID feedback (×100, %)		
		20: Motor rated torque		
		21–24: Reserved		
		25: Status word		
		26: HDIB frequency value (×1000, kHz) (reserved)		
27: PID1 reference				
28: PID1 feedback				
29: PID1 output				
30: PID2 reference value				
31: PID2 feedback value				
32: PID2 output				
33–37: Reserved				
P15.24	Reserved	-	-	-
P15.25	DP communication timeout period	0.0–60.0s	5.0s	○
P15.26	CANopen communication timeout period	0.0–60.0s	5.0s	○
P15.27	CANopen	0–7	3	⊙

Function code	Name	Description	Default	Modify
	communication baud rate	0: 1000kbps 1: 800kbps 2: 500kbps 3: 250kbps 4: 125kbps 5: 100kbps 6: 50kbps 7: 20kbps		
P15.28	CAN communication address	0–127	1	☉
P15.29	Master/slave CAN communication baud rate	0–5 0: 50kbps 1: 100kbps 2: 125kbps 3: 250kbps 4: 500kbps 5: 1Mbps	2	☉
P15.30	Master/slave CAN communication timeout period	0.0 (invalid)–60.0s	5.0s	○
P15.31	DeviceNET communication timeout period (reserved)	0.0 (invalid)–60.0s	5.0s	○
P15.32	Display node baud rate (reserved)	0–65535	0	●
P15.33	Alternation enable (reserved)	0–1	1	○
P15.34	Instance number of alternation output (Reserved)	0–27 0–18: Reserved 19: INVT VFD output 20: ODVA basic speed control output 21: ODVA extended speed control output 22: ODVA speed and torque control output 23: ODVA extended speed and torque control output 24: INVT basic speed control output	19	○

Function code	Name	Description	Default	Modify
		25: INVT extended speed control output 26: INVT speed and torque control output 27: INVT extended speed and torque control output		
P15.35	Instance number of alternation input (Reserved)	0-77 0-68: Reserved 69: INVT VFD input 70: ODVA basic speed control input 71: ODVA extended speed control input 72: ODVA speed and torque control input 73: ODVA extended speed and torque control input 74: INVT basic speed control input 75: INVT extended speed control input 76: INVT speed and torque control input 77: INVT extended speed and torque control input	69	○
P15.36	State change/cycle enable (reserved)	0-1	0	○
P15.37	State change/cycle output instance (reserved)	0-27 0-18: Reserved 19: INVT VFD output 20: ODVA basic speed control output 21: ODVA extended speed control output 22: ODVA speed and torque control output 23: ODVA extended speed and torque control output 24: INVT basic speed control output 25: INVT extended speed control output 26: INVT speed and torque control output 27: INVT extended speed and torque control output	19	○
P15.38	State change/cycle input instance (reserved)	0-77 0-68: Reserved 69: INVT VFD input 70: ODVA basic speed control input 71: ODVA extended speed control input 72: ODVA speed and torque control input	69	○

Function code	Name	Description	Default	Modify
		73: ODVA extended speed and torque control input 74: INVT basic speed control input 75: INVT extended speed control input 76: INVT speed and torque control input 77: INVT extended speed and torque control input		
P15.39	Component 19 output length (reserved)	8–32	32	○
P15.40	Component 19 input length (reserved)	8–32	32	○
P15.41	BACnet communication mode	0–1 0: P16.22 is enabled. 1: P15.42 is enabled.	1	⊙
P15.42	Baud rate of BACnet_MSTP	0–5 0: 9600 bps 1: 19200 bps 2: 38400 bps 3: 57600 bps 4: 76800 bps 5: 115200 bps	0	⊙
P15.43	Communication control word expression format (reserved)	0–1 0: Decimal format 1: Binary format	0	●
P15.44	BACnet device No. high bit	0–4194	0	⊙
P15.45	BACnet device No. low bit	0–999	1	⊙
P15.46	BACnet I-AM service selection	0–1 0: Send at power-on 1: Send constantly	0	⊙
P15.47	BACnet communication timeout time	0.0–60.0s	5.0s	○
P15.48	BACnet multi-card communication timeout time	0.0s–P15.47	0.0s	○

Group P16—Functions of communication expansion card 2

Function code	Name	Description	Default	Modify
P16.00–P16.01	Reserved	-	-	-
P16.02	Ethernet monitoring card IP address 1	0–255	192	☉
P16.03	Ethernet monitoring card IP address 2	0–255	168	☉
P16.04	Ethernet monitoring card IP address 3	0–255	0	☉
P16.05	Ethernet monitoring card IP address 4	0–255	1	☉
P16.06	Ethernet monitoring card subnet mask 1	0–255	255	☉
P16.07	Ethernet monitoring card subnet mask 2	0–255	255	☉
P16.08	Ethernet monitoring card subnet mask 3	0–255	255	☉
P16.09	Ethernet monitoring card subnet mask 4	0–255	0	☉
P16.10	Ethernet monitoring card gateway 1	0–255	192	☉
P16.11	Ethernet monitoring card gateway 2	0–255	168	☉
P16.12	Ethernet monitoring card gateway 3	0–255	0	☉
P16.13	Ethernet monitoring card gateway 4	0–255	1	☉
P16.14	Ethernet card monitoring variable address 1	0x0000–0xFFFF	0x0000	○
P16.15	Ethernet card monitoring variable address 2	0x0000–0xFFFF	0x0000	○
P16.16	Ethernet card monitoring variable address 3	0x0000–0xFFFF	0x0000	○
P16.17	Ethernet card	0x0000–0xFFFF	0x0000	○

Function code	Name	Description	Default	Modify
	monitoring variable address 4			
P16.18	Ethernet monitoring card communication timeout period (reserved)	0.0 (invalid)–60.0s	0.0s	<input type="radio"/>
P16.19	Reserved	0–4 0: 250µs 1: 500µs 2: 1ms 3: 2ms 4: Reserved	2	<input type="radio"/>
P16.20	BACnet device No. MSB (reserved)	0–4194 Note: BACnet device No. range is 0–4194303.	0	<input checked="" type="radio"/>
P16.21	BACnet device No. LSB (reserved)	0–999 Note: BACnet device No. range is 0–4194303.	1	<input checked="" type="radio"/>
P16.22	BACnet "I-Am" service selection (reserved)	0–1 0: Send at power-on 1: Send constantly	0	<input type="radio"/>
P16.23	BACnet communication timeout period (reserved)	0.0 (invalid)–60.0s	5.0s	<input type="radio"/>
P16.24	Time to identify expansion card in card slot 1	0.0 (invalid)–600.0s	0.0s	<input type="radio"/>
P16.25	Time to identify expansion card in card slot 2	0.0 (invalid)–600.0s	0.0s	<input type="radio"/>
P16.26	Time to identify expansion card in card slot 3 (reserved)	0.0 (invalid)–600.0s	0.0s	<input checked="" type="radio"/>
P16.27	Communication timeout period of	0.0 (invalid)–600.0s	0.0s	<input type="radio"/>

Function code	Name	Description	Default	Modify
	card in slot 1			
P16.28	Communication timeout period of card in slot 2	0.0 (invalid)–600.0s	0.0s	○
P16.29	Communication timeout period of expansion card in card slot 3 (reserved)	0.0 (invalid)–600.0s	0.0s	●
P16.30	Reserved	-	-	-
P16.32	Received PZD2	0–31	0	○
P16.33	Received PZD3	0: Invalid	0	○
P16.34	Received PZD4	1: Set frequency (0–Fmax, unit: 0.01Hz)	0	○
P16.35	Received PZD5	2: PID reference source 1 (-1000+1000, in which 1000 corresponds to 100.0%)	0	○
P16.36	Received PZD6	3: PID feedback source 1 (-1000–1000, in which 1000 corresponds to 100.0%)	0	○
P16.37	Received PZD7	4: Torque setting (-3000+3000, in which 1000 corresponds to 100.0% of the motor rated current)	0	○
P16.38	Received PZD8	5: Setting of the upper limit of forward running frequency (0–Fmax, unit: 0.01Hz)	0	○
P16.39	Received PZD9	6: Setting of the upper limit of reverse running frequency (0–Fmax, unit: 0.01Hz)	0	○
P16.40	Received PZD10	7: Upper limit of the electromotive torque (0–3000, in which 1000 corresponds to 100.0% of the motor rated current)	0	○
P16.41	Received PZD11	8: Upper limit of braking torque (0–3000, in which 1000 corresponds to 100% of the motor rated current)	0	○
P16.42	Received PZD12	9: Virtual input terminal command (0x000–0x3FF)	0	○
P16.32	Received PZD2	10: Virtual output terminal command (0x00–0x0F)	0	○
		11: Voltage setting (special for V/F separation) (0–1000, in which 1000 corresponds to 100% of the motor rated voltage)		

Function code	Name	Description	Default	Modify
		12: AO1 output setting 1 (-1000→+1000, in which 1000 corresponds to 100.0%) 13: AO2 output setting 2 (-1000→+1000, in which 1000 corresponds to 100.0%) 14–18: Reserved 19: PID1 reference source 1 (0–1000, in which 1000 corresponds to 100.0%) 20: PID1 feedback source 1 (0–1000, in which 1000 corresponds to 100.0%) 21: PID1 reference source 2 (0–1000, in which 1000 corresponds to 100.0%) 22: PID1 feedback source 2 (0–1000, in which 1000 corresponds to 100.0%) 23: PID2 reference source (0–1000, in which 1000 corresponds to 100.0%) 24: PID2 feedback source (0–1000, in which 1000 corresponds to 100.0%) 25: Inlet water level (0–1000, in which 1000 corresponds to 100.0%) 26: AO0 output setting 0 (-1000→+1000, in which 1000 corresponds to 100.0%) 27–31: Reserved		
P16.43	Sent PZD2	0–37	0	<input type="radio"/>
P16.44	Sent PZD3	0: Invalid	0	<input type="radio"/>
P16.45	Sent PZD4	1: Running frequency (×100, Hz)	0	<input type="radio"/>
P16.46	Sent PZD5	2: Set frequency (×100, Hz)	0	<input type="radio"/>
P16.47	Sent PZD6	3: Bus voltage (×10, V)	0	<input type="radio"/>
P16.48	Sent PZD7	4: Output voltage (×1, V)	0	<input type="radio"/>
P16.49	Sent PZD8	5: Output current (×10, A)	0	<input type="radio"/>
P16.50	Sent PZD9	6: Actual output torque (×10, %)	0	<input type="radio"/>
P16.51	Sent PZD10	7: Actual output power (×10, %)	0	<input type="radio"/>
P16.52	Sent PZD11	8: Rotation speed of running (×1, RPM)	0	<input type="radio"/>
P16.53	Sent PZD12	9: Linear speed of running (×1, m/s) 10: Ramp reference frequency 11: Fault code 12: AI1 input (×100, V) 13: AI2 input (×100, V) 14: AI3 input (×100, V)	0	<input type="radio"/>

Function code	Name	Description	Default	Modify
		15: HDIA frequency value (×1000, kHz) 16: Terminal input status 17: Terminal output status 18: PID reference (×100, %) 19: PID feedback (×100, %) 20: Motor rated torque 21–24: Reserved 25: Status word 26: Reserved 27: PID1 reference 28: PID1 feedback 29: PID1 output 30: PID2 reference value 31: PID2 feedback value 32: PID2 output 33–37: Reserved		
P16.54	EtherNet IP communication timeout period	0.0 (invalid)–60.0s Note: When an EtherNet IP communication fault occurs, the VFD reports the EtherNet IP communication fault (E-EIP).	5.0s	○
P16.55	EtherNet IP communication rate (reserved)	0–4 0: Self adaptive 1: 100M full duplex 2: 100M half duplex 3: 10M full duplex 4: 10M half duplex	0	●
P16.56–P16.57	Reserved	-	-	-
P16.58	Industrial Ethernet communication card IP address 1	0–255	192	⊙
P16.59	Industrial Ethernet communication card IP address 2	0–255	168	⊙
P16.60	Industrial Ethernet communication card IP address 3	0–255	0	⊙
P16.61	Industrial Ethernet	0–255	20	⊙

Function code	Name	Description	Default	Modify
	communication card IP address 4			
P16.62	Industrial Ethernet communication card subnet mask 1	0–255	255	☉
P16.63	Industrial Ethernet communication card subnet mask 2	0–255	255	☉
P16.64	Industrial Ethernet communication card subnet mask 3	0–255	255	☉
P16.65	Industrial Ethernet communication card subnet mask 4	0–255	0	☉
P16.66	Industrial Ethernet communication card gateway 1	0–255	192	☉
P16.67	Industrial Ethernet communication card gateway 2	0–255	168	☉
P16.68	Industrial Ethernet communication card gateway 3	0–255	0	☉
P16.69	Industrial Ethernet communication card subnet mask 4	0–255	1	☉

Group P17—Status viewing

Function code	Name	Description	Default	Modify
P17.00	Set frequency	Displays the present set frequency of the VFD. Range: 0.00Hz–P00.03	50.00Hz	●
P17.01	Output frequency	Displays the present output frequency of the VFD. Range: 0.00Hz–P00.03	0.00Hz	●
P17.02	Ramp reference frequency	Displays the present ramp reference frequency of the VFD.	0.00Hz	●

Function code	Name	Description	Default	Modify
		Range: 0.00Hz–P00.03		
P17.03	Output voltage	Displays the present output voltage of the VFD. Range: 0–1200V	0V	●
P17.04	Output current	Displays the valid value of current output current of the VFD. Range: 0.0–5000.0A	0.0A	●
P17.05	Motor rotation speed	Displays the present motor rotation speed. Range: 0–65535RPM	0 RPM	●
P17.06	Torque current	Displays the present torque current of the VFD. Range: -3000.0–3000.0A	0.0A	●
P17.07	Exciting current	Displays the present exciting current of the VFD. Range: -3000.0–3000.0A	0.0A	●
P17.08	Motor power	Displays the present motor power; 100% relative to the rated motor power. The positive value is the motoring state while the negative value is the generating state. Setting range: -300.0%–300.0% (of the motor rated power)	0.0%	●
P17.09	Motor output torque	Displays the present output torque of the VFD; 100% relative to the rated motor torque. During forward running, the positive value is the motoring state while the negative value is generating state. During reverse running, the positive value is the generating state while the negative value is the motoring state. Range: -250.0%–250.0%	0.0%	●
P17.10	Estimated motor frequency	Displays the estimated motor rotor frequency under the open-loop vector condition. Range: 0.00–P00.03	0.00Hz	●
P17.11	DC bus voltage	Displays the present DC bus voltage of the VFD. Range: 0.0–2000.0 V	0V	●
P17.12	Digital input terminal state	Displays the present digital input terminal state of the VFD. 0x0000–0x003F	0x0000	●

Function code	Name	Description	Default	Modify
		Corresponds to Reserved, HDIA, S4, S3, S2 and S1 respectively.		
P17.13	Digital output terminal status	Displays the present digital output terminal state of the VFD. 0x0000–0x000F The bits correspond to reserved, RO1, reserved, and Y1 respectively.	0x0000	●
P17.14	Digital adjustment value	Displays the adjustment on the VFD through the UP/DOWN terminal. Range: 0.00Hz–P00.03	0.00Hz	●
P17.15	Torque reference value	Relative to the percentage of the rated torque of the present motor, displaying the torque reference. Range: -300.0%–300.0%	0.0%	●
P17.16	Linear speed	0–65535	0	●
P17.17	Reserved	-	-	-
P17.18	Count value	0–65535	0	●
P17.19	AI1 input voltage	Displays the AI1 input signal. Range: 0.00–10.00V Note: When P05.50=0x11, P17.19 will display without units, with a range of 0.00 to 20.00.	0.00V	●
P17.20	AI2 input voltage	Displays the AI2 input signal. Range: -10.00V–10.00V	0.00V	●
P17.21	HDIA input frequency	Display HDIA input frequency. Range: 0.000–50.000kHz	0.000kHz	●
P17.22	HDIB input frequency (Reserved)	Range: 0.000–50.000kHz	0.000kHz	●
P17.23	PID reference value	Displays the PID reference value. Range: -100.0%–100.0%	0.0%	●
P17.24	PID feedback value	Displays the PID feedback value. Range: -100.0%–100.0%	0.0%	●
P17.25	Motor power factor	Displays the power factor of the current motor. Range: -1.00–1.00	1.00	●
P17.26	Duration of this run	Displays the duration of this run of the VFD. Range: 0–65535min	0min	●

Function code	Name	Description	Default	Modify
P17.27	Present step of simple PLC	Used to display the present step of the simple PLC function. Range: 0–15	0	●
P17.28	Motor ASR controller output	Displays the ASR controller output value under the vector control mode. Range: -300.0%–300.0% (of the motor rated current)	0.0%	●
P17.29	Open-loop SM pole angle	Displays the initial identification angle of SM. Range: 0.0–360.0°	0.0°	●
P17.30	Phase compensation of SM	Displays the phase compensation of SM. Range: -180.0–180.0	0.0	●
P17.31	High-frequency superposition current of SM	0.0%–200.0% (of the motor rated current)	0.0%	●
P17.32	Motor flux linkage	0.0%–200.0%	0.0%	●
P17.33	Exciting current reference	Displays the exciting current reference value under the vector control mode. Range: -3000.0–3000.0A	0.0A	●
P17.34	Torque current reference	Displays the torque current reference value under the vector control mode. Range: -3000.0–3000.0A	0.0A	●
P17.35	AC incoming current	Displays the valid value of incoming current on AC side. Range: 0.0–5000.0A	0.0A	●
P17.36	Actual output torque	Displays the actual output torque value of the VFD. During forward running, the positive value is the motoring state while the negative value is generating state. During reverse running, the positive value is the generating state while the negative value is the motoring state. Range: -3000.0N·m–3000.0N·m	0.0N·m	●
P17.37	Motor overload count value	0–65535	0	●
P17.38	Process PID output	-100.0%–100.0%	0.00%	●
P17.39	Function codes in parameter	0.00–99.99	0.00	●

Function code	Name	Description	Default	Modify
	download error			
P17.40	Motor control mode	0x000–0x123 Ones place: Control mode 0: Vector 0 1: Vector 1 2: VF control 3: Reserved Tens place: Control status 0: Speed control 1: Torque control 2: Reserved Hundreds place: Motor number 0: Motor 1 1: Motor 2	0x000	●
P17.41	Electromotive torque upper limit	0.0%–300.0% (of the motor rated current)	0.0%	●
P17.42	Braking torque upper limit	0.0%–300.0% (of the motor rated current)	0.0%	●
P17.43	Forward rotation upper-limit frequency in torque control	0.00Hz–P00.03	0.00Hz	●
P17.44	Reverse rotation upper-limit frequency in torque control	0.00Hz–P00.03	0.00Hz	●
P17.45	Inertia compensation torque	-100.0%–100.0%	0.0%	●
P17.46	Friction compensation torque	-100.0%–100.0%	0.0%	●
P17.47	Motor pole pairs	0–65535	0	●
P17.48	VFD overload count value	0–65535	0	●
P17.49	Frequency set by A source	0.00Hz–P00.03	0.00Hz	●
P17.50	Frequency set by B	0.00Hz–P00.03	0.00Hz	●

Function code	Name	Description	Default	Modify
	source			
P17.51	PID1 proportional output	-100.0%–100.0%	0.00%	●
P17.52	PID1 integral output	-100.0%–100.0%	0.00%	●
P17.53	PID1 differential output	-100.0%–100.0%	0.00%	●
P17.54	Present proportional gain	0.00–100.00%	0.00%	●
P17.55	Present integral time	0.00–10.00s	0.00s	●
P17.56	Present differential time	0.00–10.00s	0.00s	●
P17.57	Actual steps of multi-step speed	0–15	0	●
P17.58	100Hz component peak value (square waves quadrature)	0.0–300.0V Note: Peak-to-peak value of bus voltage fluctuation at 100Hz frequency component, which is detected by using a square-wave orthogonal function.	0.0V	●
P17.59	100Hz component peak value (sin quadrature)	0.0–300.0V Note: The peak-to-peak value of bus voltage fluctuation at 100Hz frequency component, is detected by using a sin-wave orthogonal function.	0.0V	●
P17.60	Keypad analog voltage	0.00–10.00	0.00	●

Group P19—Expansion card status viewing

Function code	Name	Description	Default	Modify
P19.00	Type of expansion card in slot 1	0–80 0: No card	0	●
P19.01	Type of expansion card in slot 2	1: Reserved 2: I/O card	0	●
P19.02	Reserved	3–4: Reserved 5: Ethernet 6: DP communication card	-	-

Function code	Name	Description	Default	Modify
		7–8: Reserved 9: CANOpen Communication card 10: Reserved 11: PROFINET communication card 12–14: Reserved 15: CAN master/slave communication card 16: Modbus TCP Communication card 17: Reserved 18: BACnet MSTP communication card 19–20: Reserved 21: Ethernet/IP communication card 22–24: Reserved 25: Water supply card 26–80: Reserved		
P19.03	Software version of expansion card in slot 1	0.00–655.35	0.00	●
P19.04	Software version of expansion card in slot 2	0.00–655.35	0.00	●
P19.05	Reserved	-	-	-
P19.06	Terminal input status of I/O card	0–0xFFFF	0	●
P19.07	Terminal output status of I/O card	0–0xFFFF	0	●
P19.08	Reserved	-	-	-
P19.09	AI3 input voltage of I/O card	0.00–10.00V	0.00V	●

Group P23—Vector control of motor 2

Function code	Name	Description	Default	Modify
P23.00	Speed-loop proportional gain 1	P23.00–P23.05 are applicable only to vector control mode. When switching frequency 1 (P23.02) is not reached, the speed-loop PI parameters are: P23.00 and P23.01. When switching frequency 2 (P23.05) is exceeded, the speed-loop PI parameters are: P23.03	20.0	○
P23.01	Speed-loop integral time 1		0.200s	○
P23.02	Low-point frequency for		5.00Hz	○

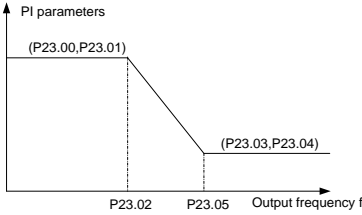
Function code	Name	Description	Default	Modify
	switching	and P23.04. PI parameters are obtained		
P23.03	Speed-loop proportional gain 2	according to the linear change of two groups of parameters. See the following figure:	20.0	<input type="radio"/>
P23.04	Speed-loop integral time 2		0.200s	<input type="radio"/>
P23.05	High-point frequency for switching	 <p>The speed loop dynamic response characteristics of vector control can be adjusted by setting the proportional coefficient and integral time of speed regulator. Increasing proportional gain or reducing integral time can accelerate dynamic response of speed loop; however, if the proportional gain is too large or integral time is too small, system oscillation and overshoot may occur; if proportional gain is too small, stable oscillation or speed offset may occur.</p> <p>PI parameters have a close relationship with the inertia of the system. Adjust PI parameters depending on different loads to meet various demands.</p> <p>Setting range of P23.00: 0.0–200.0 Setting range of P23.01: 0.000–10.000s Setting range of P23.02: 0.00Hz –P23.05 Setting range of P23.03: 0.0–200.0 Setting range of P23.04: 0.000–10.000s Setting range of P23.05: P23.02–P00.03</p>	10.00Hz	<input type="radio"/>
P23.06	Speed-loop output filter	0–8 (corresponding to 0–2 ⁸ /10ms)	0	<input type="radio"/>
P23.07	Electromotive slip compensation coefficient of vector control	Slip compensation coefficient is used to adjust the slip frequency of the vector control and improve the speed control accuracy of the system. Adjusting the parameter properly	100%	<input type="radio"/>

Function code	Name	Description	Default	Modify
P23.08	Power-generation slip compensation coefficient of vector control	can control the speed steady-state error. Setting range: 50–200%	100%	<input type="radio"/>
P23.09	Current-loop proportional coefficient P	Note: ✧ The two function codes impact the dynamic response speed and control accuracy of the system. Generally, you do not need to modify the two function codes. ✧ Applicable to SVC mode 0 (P00.00=0) only. ✧ The values of the two function codes are updated automatically after SM parameter autotuning is completed. Setting range: 0–65535	1000	<input type="radio"/>
P23.10	Current-loop integral coefficient I		1000	<input type="radio"/>
P23.11	Speed-loop differential gain	0.00–10.00s	0.00s	<input type="radio"/>
P23.12	Proportional coefficient of high-frequency current loop	In the vector control mode (P00.00=3), when the frequency is lower than the current-loop high-frequency switching threshold (P23.14), the current-loop PI parameters are P23.09 and P23.10; and when the frequency is higher than the current-loop high-frequency switching threshold, the current-loop PI parameters are P23.12 and P23.13. Setting range of P23.12: 0–65535 Setting range of P23.13: 0–65535 Setting range of P23.14: 0.0–100.0% (of the max. frequency)	1000	<input type="radio"/>
P23.13	Integral coefficient of high-frequency current loop		1000	<input type="radio"/>
P23.14	Current-loop high-frequency switching threshold		100.0%	<input type="radio"/>

Group P25—I/O card input functions

Function code	Name	Description	Default	Modify
P25.00	HDI3 input type	0–1 0: HDI3 is high-speed pulse input 1: HDI3 is digital input	0	<input checked="" type="radio"/>
P25.01	Function of S5	Same as Group P05	0	<input checked="" type="radio"/>
P25.02	Function of S6		0	<input checked="" type="radio"/>

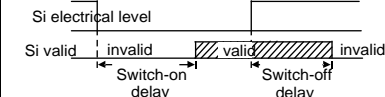
Function code	Name	Description	Default	Modify														
P25.03	Function of S7		0	⊙														
P25.04	Function of S8		0	⊙														
P25.05	Function of S9		0	⊙														
P25.06	Function of S10		0	⊙														
P25.07	Function of HDI3		0	⊙														
P25.08	Expansion card input terminal polarity	0x00–0x7F When a bit is 0, the input terminal is positive. when a bit is 1, the input terminal is negative. <table border="1" style="margin-left: 20px;"> <tr> <td>Bit0</td><td>Bit1</td><td>Bit2</td><td>Bit3</td><td>Bit4</td><td>Bit5</td><td>Bit6</td> </tr> <tr> <td>S5</td><td>S6</td><td>S7</td><td>S8</td><td>S9</td><td>S10</td><td>HDI3</td> </tr> </table>	Bit0	Bit1	Bit2	Bit3	Bit4	Bit5	Bit6	S5	S6	S7	S8	S9	S10	HDI3	0x00	○
Bit0	Bit1	Bit2	Bit3	Bit4	Bit5	Bit6												
S5	S6	S7	S8	S9	S10	HDI3												
P25.09	Expansion card virtual terminal setting	0x000–0x7F (0: disable; 1: enable) <table border="1" style="margin-left: 20px;"> <tr> <td>Bit0</td><td>Bit1</td><td>Bit2</td><td>Bit3</td><td>Bit4</td><td>Bit5</td><td>Bit6</td> </tr> <tr> <td>S5</td><td>S6</td><td>S7</td><td>S8</td><td>S9</td><td>S10</td><td>HDI3</td> </tr> </table>	Bit0	Bit1	Bit2	Bit3	Bit4	Bit5	Bit6	S5	S6	S7	S8	S9	S10	HDI3	0x00	⊙
Bit0	Bit1	Bit2	Bit3	Bit4	Bit5	Bit6												
S5	S6	S7	S8	S9	S10	HDI3												
P25.10	HDI3 switch-on delay	These function codes specify the delay time corresponding to the electrical level changes when the programmable input terminals switch on or switch off.  <p style="text-align: center;">Setting range: 0.000–50.000s</p>	0.000s	○														
P25.11	HDI3 switch-off delay		0.000s	○														
P25.12	S5 switch-on delay		0.000s	○														
P25.13	S5 switch-off delay		0.000s	○														
P25.14	S6 switch-on delay		0.000s	○														
P25.15	S6 switch-off delay		0.000s	○														
P25.16	S7 switch-on delay		0.000s	○														
P25.17	S7 switch-off delay		0.000s	○														
P25.18	S8 switch-on delay		0.000s	○														
P25.19	S8 switch-off delay		0.000s	○														
P25.20	S9 switch-on delay		0.000s	○														
P25.21	S9 switch-off delay		0.000s	○														
P25.22	S10 switch-on delay		0.000s	○														
P25.23	S10 switch-off delay		0.000s	○														
P25.24	AI3 lower limit		Used to define the relationship between the analog input voltage and its corresponding setting. When the analog input voltage exceeds the range from the upper limit to the lower limit, the upper limit or lower limit is used.	0.00V	○													
P25.25	Corresponding setting of AI3 lower limit		0.0%	○														
P25.26	AI3 upper limit		10.00V	○														
P25.27	Corresponding		100.0%	○														

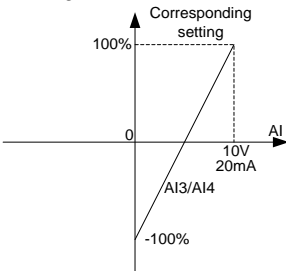
Function code	Name	Description	Default	Modify
	setting of AI3 upper limit	When the analog input is current input, 0mA–20mA current corresponds to 0V–10V voltage.		
		In different applications, 100.0% of the analog setting corresponds to different nominal values. See the descriptions of each application section for details.		
		The following figure illustrates the cases of several settings:		
P25.28	AI3 input filter time	 <p>Input filter time: to adjust the sensitivity of analog input. Increasing the value properly can enhance analog input anti-interference but may reduce the sensitivity of analog input.</p> <p>Note: AI3 can support 0–10V/0–20mA input. When AI3 selects 0–20mA input, the corresponding voltage of 20mA is 10V.</p> <p>Setting range of P25.24: 0.00V–P25.26 Setting range of P25.25: -300.0%–300.0% Setting range of P25.26: P25.24–10.00V Setting range of P25.27: -300.0%–300.0% Setting range of P25.28: 0.000s–10.000s</p>	0.030s	○
P25.29	AI4 lower limit	0.00V–P25.31	0.00V	○
P25.30	Corresponding setting of AI4 lower limit	-300.0%–300.0%	0.0%	○
P25.31	AI4 upper limit	P25.29–10.00V	10.00V	○
P25.32	Corresponding setting of AI4 upper limit	-300.0%–300.0%	100.0%	○

Function code	Name	Description	Default	Modify
P25.33	AI4 input filter time	0.000–10.000s	0.030s	<input type="radio"/>
P25.34	HDI3 high-speed pulse input function selection	0–1 0: Input set through frequency 1: Counting function	0	<input checked="" type="radio"/>
P25.35	HDI3 lower limit frequency	0.000kHz–P25.37	0.000kHz	<input type="radio"/>
P25.36	Corresponding setting of HDI3 lower limit frequency	-300.0%–300.0%	0.0%	<input type="radio"/>
P25.37	HDI3 upper limit frequency	P25.35–50.000kHz	50.000 kHz	<input type="radio"/>
P25.38	Corresponding setting of HDI3 upper limit frequency	-300.0%–300.0%	100.0%	<input type="radio"/>
P25.39	HDI3 frequency input filter time	0.000–10.000s	0.030s	<input type="radio"/>
P25.40	AI3 input signal type	0–1 0: Voltage 1: Current	0	<input type="radio"/>
P25.41	AI4 input signal type	0–1 0: Voltage 1: Current	0	<input type="radio"/>

Group P26—I/O card output functions

Function code	Name	Description	Default	Modify
P26.00	HDO2 output type	0–1 0: Open collector high-speed pulse output 1: Open collector output	0	<input checked="" type="radio"/>
P26.01	HDO2 output	Same as the description for P06.01	0	<input type="radio"/>
P26.02	Y2 output		0	<input type="radio"/>
P26.03	Y3 output		0	<input type="radio"/>
P26.04	RO3 output		0	<input type="radio"/>
P26.05	RO4 output		0	<input type="radio"/>
P26.06	RO5 output		0	<input type="radio"/>
P26.07	RO6 output		0	<input type="radio"/>

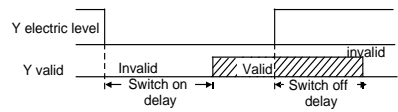
Function code	Name	Description	Default	Modify																												
P26.08	RO7 output		0	<input type="radio"/>																												
P26.09	RO8 output		0	<input type="radio"/>																												
P26.10	RO9 output		0	<input type="radio"/>																												
P26.11	RO10 output		0	<input type="radio"/>																												
P26.12	Expansion card output terminal polarity	0x0000–0x1FFF When a bit is 0, the output terminal is positive. When a bit is 1, the output terminal is negative. <table border="1" style="margin-top: 10px;"> <tr> <td>Bit0</td><td>Bit1</td><td>Bit2</td><td>Bit3</td><td>Bit4</td><td>Bit5</td><td>Bit6</td></tr> <tr> <td>Y2</td><td>Y3</td><td>HDO2</td><td>RO3</td><td>RO4</td><td>RO5</td><td>RO6</td></tr> <tr> <td>Bit7</td><td>Bit8</td><td>Bit9</td><td>Bit10</td><td>Bit11</td><td>Bit12</td><td>-</td></tr> <tr> <td>RO7</td><td>RO8</td><td>RO9</td><td>RO10</td><td>RO11</td><td>RO12</td><td>-</td></tr> </table>	Bit0	Bit1	Bit2	Bit3	Bit4	Bit5	Bit6	Y2	Y3	HDO2	RO3	RO4	RO5	RO6	Bit7	Bit8	Bit9	Bit10	Bit11	Bit12	-	RO7	RO8	RO9	RO10	RO11	RO12	-	0x0000	<input type="radio"/>
Bit0	Bit1	Bit2	Bit3	Bit4	Bit5	Bit6																										
Y2	Y3	HDO2	RO3	RO4	RO5	RO6																										
Bit7	Bit8	Bit9	Bit10	Bit11	Bit12	-																										
RO7	RO8	RO9	RO10	RO11	RO12	-																										
P26.13	HDO2 switch-on delay	Used to specify the delay time corresponding to the electrical level changes when the programmable output terminals switch on or switch off. 	0.000s	<input type="radio"/>																												
P26.14	HDO2 switch-off delay		0.000s	<input type="radio"/>																												
P26.15	Y2 switch-on delay		0.000s	<input type="radio"/>																												
P26.16	Y2 switch-off delay		0.000s	<input type="radio"/>																												
P26.17	Y3 switch-on delay		0.000s	<input type="radio"/>																												
P26.18	Y3 switch-off delay		0.000s	<input type="radio"/>																												
P26.19	RO3 switch-on delay		0.000s	<input type="radio"/>																												
P26.20	RO3 switch-off delay		0.000s	<input type="radio"/>																												
P26.21	RO4 switch-on delay		0.000s	<input type="radio"/>																												
P26.22	RO4 switch-off delay		0.000s	<input type="radio"/>																												
P26.23	RO5 switch-on delay		Setting range: 0.000–50.000s	0.000s	<input type="radio"/>																											
P26.24	RO5 switch-off delay		0.000s	<input type="radio"/>																												
P26.25	RO6 switch-on delay		0.000s	<input type="radio"/>																												
P26.26	RO6 switch-off delay	0.000s	<input type="radio"/>																													
P26.27	RO7 switch-on	0.000s	<input type="radio"/>																													

Function code	Name	Description	Default	Modify
	delay			
P26.28	RO7 switch-off delay		0.000s	<input type="radio"/>
P26.29	RO8 switch-on delay		0.000s	<input type="radio"/>
P26.30	RO8 switch-off delay		0.000s	<input type="radio"/>
P26.31	RO9 switch-on delay		0.000s	<input type="radio"/>
P26.32	RO9 switch-off delay		0.000s	<input type="radio"/>
P26.33	RO10 switch-on delay		0.000s	<input type="radio"/>
P26.34	RO10 switch-off delay		0.000s	<input type="radio"/>
P26.35	AO2 output		0	<input type="radio"/>
P26.36	AO3 output	Same as the description for P06.14	0	<input type="radio"/>
P26.37	Reserved		-	-
P26.38	AO2 output lower limit	The function codes define the relationship between the output value and analog output.	0.0%	<input type="radio"/>
P26.39	AO2 output corresponding to lower limit	When the output value exceeds the allowed range, the output uses the lower limit or upper limit.	0.00V	<input type="radio"/>
P26.40	AO2 output upper limit	When the analog output is current output, 1mA equals 0.5V.	100.0%	<input type="radio"/>
P26.41	AO2 output corresponding to upper limit	In different cases, the corresponding analog output of 100% of the output value is different.	10.00V	<input type="radio"/>
P26.42	AO2 output filter time		0.000s	<input type="radio"/>
P26.43	AO3 output lower limit		0.0%	<input type="radio"/>
P26.44	AO3 output corresponding to lower limit		0.00V	<input type="radio"/>
P26.45	AO3 output upper limit		100.0%	<input type="radio"/>
P26.46	AO3 output		10.00V	<input type="radio"/>

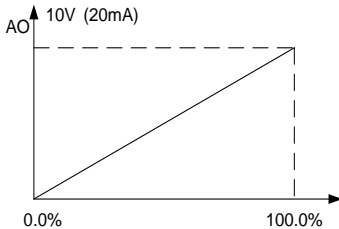

Setting range of P26.38: -300.0%–P26.40

Setting range of P26.39: 0.00V–10.00V

Setting range of P26.40: P26.38–100.0%

Setting range of P26.41: 0.00V–10.00V

Function code	Name	Description	Default	Modify
	corresponding to upper limit	Setting range of P26.42: 0.000s–10.000s Setting range of P26.43: -300.0%–P26.45		
P26.47	AO3 output filter time	Setting range of P26.44: 0.00V–10.00V Setting range of P26.45: P26.43–300.0% Setting range of P26.46: 0.00V–10.00V Setting range of P26.47: 0.000s–10.000s	0.000s	<input type="radio"/>

Group P28—Master/slave control

Function code	Name	Description	Default	Modify
P28.00	Master/slave mode	0: Master/slave control is invalid. 1: The local device is the master. 2: The local device is the slave.	0	<input checked="" type="radio"/>
P28.01	Master/slave communication data selection	0: CAN 1: Reserved	0	<input checked="" type="radio"/>
P28.02	Master/slave control mode	0x000–0x112 Ones place: Master/slave running mode 0: Master/slave mode 0 The master and slave use speed control, with power balanced through droop control. 1: Master/slave mode 1 The master and slave must be in the same type of vector control. When the master is in speed control, the slave is forced into torque control. 2: Master/slave mode 2 The slave switches from speed mode (master/slave mode 0) to torque mode (master/slave mode 1) at a frequency point. Tens place: Slave start command source 0: Master 1: Determined by P00.01 Hundreds place: Whether to enable master/slave to send/receive data 0: Enable 1: Disable	0x001	<input checked="" type="radio"/>
P28.03	Slave speed gain	0.0–500.0%	100.0%	<input type="radio"/>

Function code	Name	Description	Default	Modify
P28.04	Slave torque gain	0.0–500.0%	100.0%	<input type="radio"/>
P28.05	Frequency point for switching between speed mode and torque mode	0.00–10.00Hz Note: Valid in master-slave mode 2.	5.00Hz	<input type="radio"/>
P28.06	Number of slaves	0–15	1	<input checked="" type="radio"/>

Group P89—HVAC status viewing

Function code	Name	Description	Default	Modify
P89.00	HVAC function status	0: Invalid 1: Valid	0	<input checked="" type="radio"/>
P89.01	Variable-frequency motor run sequence	1–8 The sequences 1–8 correspond to motors A–F. For fixed variable-frequency motors, the value is 255.	1	<input checked="" type="radio"/>
P89.02	Multi-motor validity status	0x00–0xFF Bit 0–Bit 7 correspond to motor A–motor H. 0: The corresponding motor is invalid and cannot be put into service. 1: The corresponding motor is valid and can be put into service.	0x00	<input checked="" type="radio"/>
P89.03	Power-frequency motor run status	0x00–0xFF Bit 0–Bit 7 correspond to motor A–motor H. 0: The corresponding motor stops. 1: The corresponding motor is running.	0x00	<input checked="" type="radio"/>
P89.04	SN of power-frequency motor to be polled	1–8	1	<input checked="" type="radio"/>
P89.05	Left time of power-frequency motor to be polled	0.00–600.00h	0.00h	<input checked="" type="radio"/>
P89.06	SN of variable-frequency motor to be polled	1–8	1	<input checked="" type="radio"/>
P89.07	Left time of variable-frequency motor to be polled	0.00–600.00h	0.00h	<input checked="" type="radio"/>

Function code	Name	Description	Default	Modify
P89.08	PID1 status	Bit0: Stop Bit1: Pause Bit2: Deviation deadzone Bit3: Polarity reversal	0x0	●
P89.09	Present reference value of PID1	-100.0%–100.0%	0.0%	●
P89.10	PID1 feedback value	-100.0%–100.0%	0.0%	●
P89.11	PID1 deviation input	-100.0%–100.0%	0.0%	●
P89.12	Proportional output value of PID1	-1000.0%–1000.0%	0.0%	●
P89.13	Integral output value of PID1	-100.00%–100.00%	0.00%	●
P89.14	PID1 differential output	-1000.0%–1000.0%	0.0%	●
P89.15	Comprehensive output of PID1	-100.00%–100.00%	0.00%	●
P89.16	PID2 status	Bit0: Stop Bit1: Pause Bit2: Deviation deadzone Bit3: Polarity reversal	0x0	●
P89.17	Present reference value of PID2	-100.0%–100.0%	0.0%	●
P89.18	PID2 feedback value	-100.0%–100.0%	0.0%	●
P89.19	PID2 deviation input	-100.0%–100.0%	0.0%	●
P89.20	Proportional output value of PID2	-1000.0%–1000.0%	0.0%	●
P89.21	Integral output value of PID2	-100.00%–100.00%	0.00%	●
P89.22	PID2 differential output	-1000.0%–1000.0%	0.0%	●
P89.23	Comprehensive output of PID2	-100.0%–100.0%	0.0%	●
P89.24	Accumulative run	0–65535h	0h	●

Function code	Name	Description	Default	Modify
	time of motor A			
P89.25	Accumulative run time of motor B	0–65535h	0h	●
P89.26	Accumulative run time of motor C	0–65535h	0h	●
P89.27	Accumulative run time of motor D	0–65535h	0h	●
P89.28	Accumulative run time of motor E	0–65535h	0h	●
P89.29	Accumulative run time of motor F	0–65535h	0h	●
P89.30	Accumulative run time of motor G	0–65535h	0h	●
P89.31	Accumulative run time of motor H	0–65535h	0h	●
P89.32	AI/AO measured temperature	-20.0–200.0°C	0°C	●

Group P90—PID1 control

Function code	Name	Description	Default	Modify
P90.00	Unit selection	0–21 0: MPa 1: kPa 2: Pa 3: A 4: V 5: % 6: m/s 7: m/min 8: m/h 9: m ³ /s 10: m ³ /min 11: m ³ /h 12: kg/s 13: kg/min 14: kg/h 15: °C	0	⊙

Function code	Name	Description	Default	Modify
		16: °F 17: bar 18: mbar 19: L/s 20: L/min 21: L/h		
P90.01	Number of decimal places	0–3	2	☉
P90.02	PID1 given max. value	0.00–30.00 It is displayed with two decimal places by default. If P90.01 is changed, the number of decimal places changes.	10.00	○
P90.03	PID1 reference upper limit	P90.04–P90.02	10.00	○
P90.04	PID1 reference lower limit	0.00–P90.03	0.00	○
P90.05	ACC/DEC time of PID1 reference value	0.0–1000.0s	0.0s	○
P90.06	PID1 reference source 1	0–6 0: Keypad (P90.07) 1: AI1 2: AI2 3: AI3 4: HDIA 5: Reserved 6: Communication card	0	○
P90.07	PID1 reference value 1 through keypad	P90.04–P90.03	0.100	○
P90.08	PID1 feedback source 1	0–6 0: Keypad (P90.09) 1: AI1 2: AI2 3: AI3 4: HDIA 5: Reserved 6: Communication card	0	○

Function code	Name	Description	Default	Modify
P90.09	PID1 feedback value 1 through keypad	P90.04–P90.03	0.100	<input type="radio"/>
P90.10	Gain of PID1 feedback source 1	0.000–3.000	1.000	<input type="radio"/>
P90.11	PID1 reference source 2	0–6 0: Keypad (P90.12) 1: AI1 2: AI2 3: AI3 4: HDIA 5: Reserved 6: Communication card	0	<input type="radio"/>
P90.12	PID1 reference value 2 through keypad	P90.04–P90.03	0.100	<input type="radio"/>
P90.13	PID1 feedback source 2	0–6 0: Keypad (P90.14) 1: AI1 2: AI2 3: AI3 4: HDIA 5: Reserved 6: Communication card	0	<input type="radio"/>
P90.14	PID1 feedback value 2 through keypad	P90.04–P90.03	0.100	<input type="radio"/>
P90.15	Gain of PID1 feedback source 2	0.000–3.000	1.000	<input type="radio"/>
P90.16	Feedback function combination	0–7 0: No combination, feedback source 1 1: Sum of feedback sources 1 and 2 1: Difference between feedback sources 1 and 2 3: Average of feedback sources 1 and 2 4: Minimum of feedback sources 1 and 2 5: Maximum of feedback sources 1 and 2 6: Min. positive difference or max. negative	0	<input type="radio"/>

Function code	Name	Description	Default	Modify
		<p>difference among multiple reference values When calculating the difference between reference source 1 and feedback source 1 and the difference between reference source 2 and feedback source 2, give priority to the condition in which the feedback is greater than the reference.</p> <p>If there are some feedback values that are greater than the reference values, select the group with the max. negative difference as the PID reference and feedback. If all feedback values are less than the reference values, select the group with the min. positive difference as the PID reference and feedback.</p> <p>7: Max. positive difference or min. negative difference among multiple reference values When calculating the difference between reference source 1 and feedback source 1 and the difference between reference source 2 and feedback source 2, give priority to the condition in which the feedback is less than the reference.</p> <p>If there are some feedback values that are less than the reference values, select the group with the max. positive difference as the PID reference and feedback. If all feedback values are greater than the reference values, select the group with the min. negative difference as the PID reference and feedback.</p>		
P90.17	Feedback upper limit detection value	0-100.0%	100.0%	<input type="radio"/>
P90.18	Feedback lower limit detection value	0-100.0%	0.0%	<input type="radio"/>
P90.19	Feedback out-of-range detection time	0.0-3600.0s	1.0s	<input type="radio"/>
P90.20	PID1 feedback filter time	0.000-60.000s	0.000s	<input type="radio"/>

Function code	Name	Description	Default	Modify
P90.21	PID1 deviation input limit value	0.0–100.0%	100.0%	<input type="radio"/>
P90.22	Output characteristics selection	0: PID output is positive. 1: PID output is negative.	0	<input type="radio"/>
P90.23	PID1 output gain	0.000–3.000	1.000	<input type="radio"/>
P90.24	PID1 output filter time	0.000–60.000s	0.100s	<input type="radio"/>
P90.25	PID1 output upper limit	P90.26–100.0%	100.0%	<input type="radio"/>
P90.26	PID1 output lower limit	-100.0%–P90.25	0.0%	<input type="radio"/>
P90.27	Proportional gain	0.000–60.000	1.000	<input type="radio"/>
P90.28	Integral time	0.000–60.000s	5.000s	<input type="radio"/>
P90.29	Differential time	0.000–60.000s	0.000s	<input type="radio"/>
P90.30	Sampling period	0.001–60.000s	0.100s	<input type="radio"/>
P90.31	PID1 control deadzone	0.0–100.0%	0.0%	<input checked="" type="radio"/>
P90.32	Deadzone delay	0.0–300.0s The PID suspends the regulation when the PID input deviation is kept for the deadzone retaining delay time.	1.0s	<input checked="" type="radio"/>
P90.33	Integral separation threshold	0.0–100.0%	100.0%	<input type="radio"/>
P90.34	Differential filter times	0–40	10	<input type="radio"/>
P90.35	Prior differential processing	0: Perform differential processing on feedback with priority 1: Perform differential processing on deviation with priority	0	<input type="radio"/>

Group P91—PID2 control

Function code	Name	Description	Default	Modify
P91.00	Unit selection	0–21 0: MPa 1: kPa 2: Pa	0	<input checked="" type="radio"/>

Function code	Name	Description	Default	Modify
		3: A 4: V 5: % 6: m/s 7: m/min 8: m/h 9: m ³ /s 10: m ³ /min 11: m ³ /h 12: kg/s 13: kg/min 14: kg/h 15: °C 16: °F 17: bar 18: mbar 19: L/s 20: L/min 21: L/h		
P91.01	Number of decimal places	0–3	2	☉
P91.02	PID2 given max. value	0.00–30.00 It is displayed with two decimal places by default. If P90.01 is changed, the number of decimal places changes.	10.00	○
P91.03	PID2 reference upper limit	P91.04–P91.02	10.00	○
P91.04	PID2 reference lower limit	0.000–P91.03	0	○
P91.05	ACC/DEC time of PID2 reference value	0.0–1000.0s	0.0s	○
P91.06	PID2 reference source 1	0: Keypad (P91.07) 1: AI1 2: AI2 3: AI3 4: HDIA 5: Reserved	0	○

Function code	Name	Description	Default	Modify
		6: Communication card		
P91.07	PID2 reference value 1 through keypad	P91.04–P91.03	0.100	<input type="radio"/>
P91.08	PID2 feedback source 1	0: Keypad (P91.09) 1: AI1 2: AI2 3: AI3 4: HDIA 5: Reserved 6: Communication card	0	<input type="radio"/>
P91.09	PID2 feedback value 1 through keypad	P91.04–P91.03	0.100	<input type="radio"/>
P91.10	Gain of PID2 feedback source 1	0.000–3.000	1.000	<input type="radio"/>
P91.11	PID2 startup feedback value	0.00–P91.02 It is displayed with two decimal places by default. If P90.01 is changed, the number of decimal places changes. When P91.15 is set to 1 or the enabling terminal is valid, if the output is positive, the feedback is less than the value of this function code; if the output is negative, the feedback is greater than the value of this function code. After the situation lasts for the time specified by P91.12, PID2 automatically starts.	10.00	<input type="radio"/>
P91.12	PID2 startup delay	0.0–300.0s	1.0s	<input type="radio"/>
P91.13	PID2 stop feedback value	0.00–P91.02 It is displayed with two decimal places by default. If P90.01 is changed, the number of decimal places changes.	10.00	<input type="radio"/>
P91.14	PID2 stop delay	0.0–300.0s	1.0s	<input type="radio"/>
P91.15	Enabling PID2	0: Invalid 1: Valid	0	<input type="radio"/>
P91.16	Reserved	-	-	-
P91.17	Feedback upper limit detection	0–100.0%	100.0%	<input type="radio"/>

Function code	Name	Description	Default	Modify
	value			
P91.18	Feedback lower limit detection value	0–100.0%	0.0%	<input type="radio"/>
P91.19	Feedback out-of-range detection time	0.0–3600.0s	1.0s	<input type="radio"/>
P91.20	PID2 feedback filter time	0.000–60.000s	0.000s	<input type="radio"/>
P91.21	PID2 deviation input limit value	0.0–100.0%	100.0%	<input type="radio"/>
P91.22	Output characteristics selection	0: PID output is positive. 1: PID output is negative.	0	<input type="radio"/>
P91.23	PID2 output gain	0.000–3.000	1.000	<input type="radio"/>
P91.24	PID2 output filter time	0.000–60.000s	0.000s	<input type="radio"/>
P91.25	PID2 output upper limit	P91.26–100.0%	100.0%	<input type="radio"/>
P91.26	PID2 output lower limit	-100.0–P91.25	0.0%	<input type="radio"/>
P91.27	Proportional gain	0.000–60.000	1.000	<input type="radio"/>
P91.28	Integral time	0.000–60.000s	5.000s	<input type="radio"/>
P91.29	Differential time	0.000–60.000s	0.000s	<input type="radio"/>
P91.30	Sampling period	0.001–60.000s	0.100s	<input type="radio"/>
P91.31	PID2 control deadzone	0.0–100.0%	0.0%	<input checked="" type="radio"/>
P91.32	Deadzone delay	0.0–300.0s The PID suspends the regulation when the PID input deviation is kept for the deadzone retaining delay time.	1.0s	<input type="radio"/>
P91.33	Integral separation threshold	0.0–200.0%	200.0%	<input type="radio"/>
P91.34	Differential filter times	0–40	10	<input type="radio"/>
P91.35	Prior differential processing	0: Perform differential processing on feedback with priority	0	<input type="radio"/>

Function code	Name	Description	Default	Modify
		1: Perform differential processing on deviation with priority		

Group P92—Real-time clock and timer (available at use of LCD keypad)

Function code	Name	Description	Default	Modify
P92.00	Displaying year	2020–2099 YY	2020 YY	●
P92.01	Displaying month and date	01.01–12.31 MMDD	01.01 MMDD	●
P92.02	Displaying day of a week	1–7 (Corresponding to Monday through Sunday)	1	●
P92.03	Displaying hour and minute	00.00–23.59 HHMM 00.00 is the earliest hour and time of a day, while 23.59 is the latest hour and time of a day.	00.00 HHMM	●
P92.04	Setting working days	Bit 0–bit 6 correspond to Monday–Sunday. Setting instances: Monday: 0x01 Wednesday: 0x04 From Monday to Friday: 0x1F From Saturday to Sunday: 0x60	0	○
P92.05	VFD startup hour and minute	00.00–23.59 HH.MM	00.00 HH.MM	○
P92.06	VFD startup second	0–59s	0s	○
P92.07	VFD stop hour and minute	00.00–23.59 HH.MM	00.00 HH.MM	○
P92.08	VFD stop second	0–59s	0s	○
P92.09	Clock fault	0: Disable 1: Enable	0	○
P92.10	Actual second	0–59s	0s	●

Group P93—Fire control

Function code	Name	Description	Default	Modify
P93.00	Fire mode	0–2 0: Invalid	0	◎

Function code	Name	Description	Default	Modify
		1: Fire mode 1 2: Fire mode 2 When P93.00=0, the fire mode is invalid, the VFD runs in normal mode and it stops if suffering a fault. When P93.00 is a non-zero value and the fire signal is activated, the fire mode is valid, and the VFD runs at the speed specified by P93.01. If fire mode 1 is selected, the VFD always runs except it is damaged. If fire mode 2 is selected, the VFD always runs except it stops upon the following faults: OUT1, OUT2, OUT3, OC1, OC2, OC3, OV1, OV2, OV3, and SPO.		
P93.01	Running frequency in fire mode	0.00Hz–P00.03 (Max. output frequency)	50.00Hz	<input type="radio"/>
P93.02	Motor running direction in fire mode	0: Run at the default direction. 1: Run at the opposite direction.	0	<input type="radio"/>
P93.03	Fire mode flag	0–1 If the fire mode duration reaches 5 minutes, this flag is set to 1, and no warranty repair is granted.	0	<input checked="" type="radio"/>
P93.04	Actual month and date when fire activated	01.01–12.31	00.00	<input checked="" type="radio"/>
P93.05	Actual time when fire activated	00.00–23.59	00.00	<input checked="" type="radio"/>
P93.06–P93.09	Reserved	-	-	-

Group P94—Multi-pump and fan control functions

Function code	Name	Description	Default	Modify
P94.00	Multi-pump and fan control function enabling	0–1 0: Invalid 1: Valid	0	<input type="radio"/>

Function code	Name	Description	Default	Modify
P94.01	Sleep method selection	0-2 0:Sleep according to terminal input 1:Sleep according to run frequency 2:Sleep according to deviation	0	<input type="radio"/>
P94.02	Sleep start frequency	P00.05-P00.04 (Upper limit frequency) When the running frequency is less than or equal to the value and this situation lasts the time longer than P94.04, sleep is allowed.	5.00Hz	<input type="radio"/>
P94.03	Sleep starting deviation	0.0-30.0% (relative to PID1 max. value) When output is positive, if the feedback is greater than the reference, sleep is allowed only when the absolute difference is greater than the value of this function code and the situation lasts the time longer than P94.04. When output is negative, if the feedback is less than the reference, sleep is allowed only when the absolute difference is greater than the value of this function code and this situation lasts the time longer than P94.04.	5.0%	<input type="radio"/>
P94.04	Sleep delay	P94.49-3600.0s	60.0s	<input type="radio"/>
P94.05	PID1 reference boost value	-100.0-100.0% (relative to the reference value of PID1)	10.0%	<input type="radio"/>
P94.06	Longest boost time	0.0-6000.0s This function is used for continuous VFD running when the running frequency reaches the upper limit frequency but the feedback value cannot reach the setting after boost. In this situation, the VFD enters the sleep mode at once after the boost time.	10.0s	<input type="radio"/>
P94.07	Sleep wakeup frequency	P00.05-P00.04 (Upper limit frequency) In closed-loop PID, the PID output is superimposed directly from the corresponding value of this frequency when the VFD is woken up.	5.00Hz	<input type="radio"/>
P94.08	Wake-up-from-sleep deviation	0.0-30.0% (relative to PID1 max. value) In closed-loop PID, when output is positive, if the feedback is less than the reference, wakeup is allowed only when the actual	5.0%	<input type="radio"/>

Function code	Name	Description	Default	Modify
		<p>difference is greater than the value of this function code and this situation lasts the time longer than P94.09.</p> <p>When output is negative, if the feedback is greater than the reference, wakeup is allowed only when the actual difference is greater than the value of this function code and this situation lasts the time longer than P94.09.</p>		
P94.09	Wake-up-from-sleep delay	0.0–3600.0s Min. sleep time	5.0s	○
P94.10	Variable-frequency motor run mode	<p>0: Fixed Motor A is a variable-frequency motor. The other motors are power-frequency motors. When a fixed VF motor is selected, if motors A to D are set as VF motors, this setting becomes invalid. If multiple motors are used, the corresponding motors can only be set as power frequency motors. At this time, the GD270 can form a system with a maximum of 1 fixed VF motor and 4 power frequency motors.</p> <p>1: Circular According to the wiring method in the appendix, use the relays and motors with the same quantity to achieve cyclic power/variable frequency switchover. When set as a cyclic VF motor, at least two of the motors A to D must be set as VF motors. In this case, the GD270 can form a system with a maximum of 4 VF motors.</p>	1	◎
P94.11	Total number of motors	0–8, corresponding to motors A–H. The sequence numbers must be successive.	1	◎
P94.12–P94.18	Reserved	-	-	-
P94.19	Pressure tolerance for motor adding	0.0–30.0% (relative to PID1 max. value)	5.0%	○
P94.20	Running frequency for motor adding	P94.25 (Running frequency for motor reducing)–P00.03	50.00Hz	○

Function code	Name	Description	Default	Modify
P94.21	Motor adding delay	0.0–3600.0s	10.0s	<input type="radio"/>
P94.22	Switching frequency for variable-frequency motor adding	P00.05 (Lower limit frequency)–P00.03	50.00Hz	<input type="radio"/>
P94.23	Variable-frequency motor DEC time for power-frequency motor adding	0.0–300.0s	10.0s	<input type="radio"/>
P94.24	Pressure tolerance for motor reducing	0.0–30.0% (relative to PID1 max. value)	4.0%	<input type="radio"/>
P94.25	Running frequency for motor reducing	P00.05–P94.20 (Running frequency for motor adding)	5.00Hz	<input type="radio"/>
P94.26	Motor reducing delay	0.0–3600.0s	10.0s	<input type="radio"/>
P94.27	Variable-frequency motor action for motor reducing	0: Keep the frequency unchanged 1: Accelerate to the motor running frequency	1	<input type="radio"/>
P94.28	Variable-frequency motor ACC time for motor reducing	0.0–300.0s	10.0s	<input type="radio"/>
P94.29	Multi-motor pressure loss compensation	0: No 1: Yes	0	<input type="radio"/>
P94.30	Pressure reference boost value for one auxiliary motor	0.0–100.0% (relative to PID1 reference value)	5.0%	<input type="radio"/>
P94.31	Pressure reference boost value for two auxiliary motors	0.0–100.0% (relative to PID1 reference value)	10.0%	<input type="radio"/>
P94.32	Pressure reference boost value for three auxiliary motors	0.0–100.0% (relative to PID1 reference value)	15.0%	<input type="radio"/>
P94.33	Reserved	-	-	-
P94.34	Motor alternation cycle	0.0–6000.0h Automatic alternation is targeted at idle variable-frequency motors. The value 0	0.0h	<input type="radio"/>

Function code	Name	Description	Default	Modify
		indicates no alternation.		
P94.35	Alternation frequency threshold	P00.05–P00.03 When the running frequency is greater than the value of this function code, variable-frequency motor polling is not performed. Otherwise, great water pressure change impacts water supply.	45.00Hz	<input type="radio"/>
P94.36	Contactor closing delay	0.2–100.0s The delay starts after the contactor closing command is given. The VFD startup command is given after the delay since actual contactor closing also takes some time.	0.5s	<input type="radio"/>
P94.37	Contactor opening delay	0.2–100.0s Some time is taken from giving the contactor opening command to actual contactor opening. After the delay, the VFD controls the motor to switch to power frequency.	0.5s	<input type="radio"/>
P94.38	Manual soft startup switching frequency	0.00Hz–P00.03 Used to check whether a motor can run properly.	50.00Hz	<input type="radio"/>
P94.39	Water level signal input selection of inlet pool	0: None 1: Digital 2: AI1 3: AI2 4: AI3 5: HDIA 6: Reserved 7: Communication card	0	<input type="radio"/>
P94.40	Water level upper limit of inlet pool	0.0–100.0%	60.0%	<input type="radio"/>
P94.41	Water level lower limit of inlet pool	0.0%–P94.40	40.0%	<input type="radio"/>
P94.42	Water shortage level of inlet pool	0.0%–P94.41	20.0%	<input type="radio"/>
P94.43	Backup pressure upon exceptions	0.0–100.0% (relative to PID1 max. value)	0.0%	<input type="radio"/>
P94.44	Protection value for PID1 feedback too	0.0–100.0% (relative to PID1 max. value)	10.0%	<input type="radio"/>

Function code	Name	Description	Default	Modify
	low			
P94.45	Delay of PID1 feedback too low	0.0–3600.0s Corresponding terminal output that is set when PID1 feedback value is less than P94.44 and this situation lasts the time longer than P94.45.	500.0s	<input type="radio"/>
P94.46	Protection value for PID1 feedback too high	0.0–100.0% (relative to PID1 max. value)	80.0%	<input type="radio"/>
P94.47	Delay of PID1 feedback too high	0.0–3600.0s Corresponding terminal output that is set when PID1 feedback value is greater than P94.46 and this situation lasts the time longer than P94.47.	500.0s	<input type="radio"/>
P94.48	DEC time of emergency stop	0.0–600.0s	2.0s	<input type="radio"/>
P94.49	ACC time with water pump frequency	0.0s–P94.04	Model depended (2.0s)	<input type="radio"/>
P94.50	DEC time with water pump frequency	0.0s–P94.04	Model depended (2.0s)	<input type="radio"/>

Group P95—Multi-section water pressure function (LCD keypad required)

Function code	Name	Description	Default	Modify
P95.00	Actual time	00.00–23.59 Set the clock date and time in group P92.	00.00	<input checked="" type="radio"/>
P95.01	Number of pressure segments	0–8 (0 indicates that this function is disabled.)	0	<input type="radio"/>
P95.02	Start time of T1	After the Tx moment, the water pressure will become the pressure of the Tx period. The water pressure before T1 is set to 0.	00.00	<input type="radio"/>
P95.03	Pressure at T1		0.0%	<input type="radio"/>
P95.04	Start time of T2	You need to set the end time segment. The segment selection in P95.01 indicates the number of valid segments. Settings beyond the selected segments will be invalid.	23.00	<input type="radio"/>
P95.05	Pressure at T2		0.0%	<input type="radio"/>
P95.06	Start time of T3	If the start time of Tx is later than the start	23.00	<input type="radio"/>
P95.07	Pressure at T3		0.0%	<input type="radio"/>
P95.08	Start time of T4		23.00	<input type="radio"/>
P95.09	Pressure at T4		0.0%	<input type="radio"/>

Function code	Name	Description	Default	Modify
P95.10	Start time of T5	time of T(x+1), T(x+1) automatically changes to Tx. Start time range of Tx: 00.00–23.59 Pressure range of Tx period: 0.0–100.0%	23.00	<input type="radio"/>
P95.11	Pressure at T5		0.0%	<input type="radio"/>
P95.12	Start time of T6		23.00	<input type="radio"/>
P95.13	Pressure at T6		0.0%	<input type="radio"/>
P95.14	Start time of T7		23.00	<input type="radio"/>
P95.15	Pressure at T7		0.0%	<input type="radio"/>
P95.16	Start time of T8		23.59	<input type="radio"/>
P95.17	Pressure at T8		0.0%	<input type="radio"/>

Group P96—Multi-pump and fan protection function

Function code	Name	Description	Default	Modify
P96.00	Action upon water pipe break	0–1 0: Disable 1: Report a fault	0	<input type="radio"/>
P96.01	Detection level of water pipe break	After water pipe break, the VFD running frequency boosts up to the upper limit or the PID output upper limit frequency. When it is set to 0, the water pipe break detection function is invalid. Range: 0.0–100.0%	10.0%	<input type="radio"/>
P96.02	Detection time of water pipe break	Used to check the detection time of water pipe break. Range: 0.0–6000.0s	120.0s	<input type="radio"/>
P96.03	Water pipe soft padding function	0: Disable 1: Enable	0	<input type="radio"/>
P96.04	Reference frequency for soft padding	0.00Hz–P00.03	30.00Hz	<input type="radio"/>
P96.05	Duration of reference frequency for soft padding	0.0–6000.0s	10.0s	<input type="radio"/>
P96.06	Soft padding cutoff detection level	The PID function is valid when the feedback value is greater than the value of this function code. Range: 0.0–100.0%	30.0%	<input type="radio"/>
P96.07–	Reserved	-	-	-

Function code	Name	Description	Default	Modify
P96.09				
P96.10	Enabling freezing protection	<p>0–1 0: Disable 1: Enable</p> <p>Freezing protection: The freezing protection signal is activated when the detected temperature is lower than the protection threshold; this signal is ignored if the VFD is running.</p> <p>If the run command is received after the protection has been activated, the protection is terminated and the run command is executed.</p> <p>If a stop command is received after the protection has been activated, the motor is stopped and automatic protection is disabled. Automatic protection can be enabled only when the temperature is higher than the protection threshold.</p>	0	<input type="radio"/>
P96.11	Temperature sensor type	<p>0–6 0: Invalid 1: PT100 2: PT1000 3: KTY84 4: PTC (AO+AI terminal combination) 5: PTC (AI1+10V terminal combination) 6: PTC (AI2+10V terminal combination)</p> <p>Usage of functions 1–4: To select current-type output for AO, connect one end of the temperature resistor to AI1 (voltage-type) and AO1 (current-type), and the other end to GND.</p> <p>Usage of functions 5–6: Connect the PTC sensor between the +10V terminal and AI1 or AI2.</p>	0	<input type="radio"/>
P96.12	Freezing protection threshold	-20.0–20.0°C	-5.0°C	<input type="radio"/>
P96.13	Low temperature	-20.0–20.0°C	0.0°C	<input type="radio"/>

Function code	Name	Description	Default	Modify
	pre-alarm threshold	When the temperature is lower than the value of this function code, the pre-alarm terminal outputs a signal.		
P96.14	Freezing protection frequency	0.00–45.00	0.00Hz	<input type="radio"/>
P96.15	Current of triggering condensation protection	0.0–100.0% When an external terminal triggers the condensation protection signal, the VFD transfers DC current and stops the transfer if the duration reaches 40s. The condensation protection signal needs to be triggered again.	30.0%	<input type="radio"/>
P96.16–P96.19	Reserved	-	-	-
P96.20	Forward run frequency for pump cleaning	0.00Hz–P00.04	50.00Hz	<input type="radio"/>
P96.21	Reverse run frequency for pump cleaning	0.00Hz–P00.04	50.00Hz	<input type="radio"/>
P96.22	Forward run ACC time for pump cleaning	0.0–3600.0s	5.0s	<input type="radio"/>
P96.23	Reverse run ACC time for pump cleaning	0.0–3600.0s	5.0s	<input type="radio"/>
P96.24	Forward run duration for pump cleaning	0.0–3600.0s	5.0s	<input type="radio"/>
P96.25	Reverse run duration for pump cleaning	0.0–3600.0s	5.0s	<input type="radio"/>
P96.26	Forward/reverse run interval for pump cleaning	0.0–3600.0s	1.0s	<input type="radio"/>
P96.27	Number of pump cleaning cycles	1–1000	1	<input type="radio"/>
P96.28	Motor stalling function selection	0–2 0: Disable	0	<input type="radio"/>

Function code	Name	Description	Default	Modify
		1: Pre-alarm 2: Faulty Prerequisite for selecting the function: The VFD exceeds the stalling current limit, the output frequency is lower than the stalling frequency upper limit, and the duration of this situation exceeds the stalling time.		
P96.29	Stalling current limit	0.0–300.0% (100.0% corresponds to the motor rated current.)	200.0%	<input type="radio"/>
P96.30	Stalling frequency upper limit	0.00Hz–P00.04 Note: It cannot be lower than 10Hz.	15.00Hz	<input type="radio"/>
P96.31	Stalling detection time	0.0–3600.0s	2.0s	<input type="radio"/>
P96.32	Motor dry pumping function selection	0–2 0: Disable 1: Pre-alarm 2: Faulty	0	<input type="radio"/>
P96.33	Current limit for motor dry pumping	0.0–100.0% (100.0% corresponds to the motor rated current.)	0.0%	<input type="radio"/>
P96.34	Detection time for motor dry pumping	0.0–3600.0s	2.0s	<input type="radio"/>
P96.35	Motor overtemperature protection threshold	-20.0–200.0	110.0	<input type="radio"/>
P96.36	AI/AO detected temperature offset value	-40.0–40.0	0.0	<input type="radio"/>
P96.37	PTC constant output current setting	0.000–20.000mA	4.000mA	<input type="radio"/>
P96.38	PTC resistance alarm threshold	0–60000Ω	750Ω	<input type="radio"/>
P96.39	PTC resistance alarm recovery threshold	0–60000Ω	150Ω	<input type="radio"/>
P96.40	Actual PTC resistance	0–60000Ω	0Ω	<input checked="" type="radio"/>

Function code	Name	Description	Default	Modify
P96.41	PTC AI1 temperature compensation coefficient	0-100	50	<input type="radio"/>
P96.42	PTC AI2 temperature compensation coefficient	0-100	50	<input type="radio"/>

7 Troubleshooting

7.1 What this chapter contains

The chapter tells you how to reset faults and check faults history. A complete list of alarms and fault information as well as possible causes and corrective measures are presented in this chapter.



Only trained and qualified professionals are allowed to carry out the operations mentioned in this chapter. Please carry out operations according to instructions presented in chapter 1 Safety precautions.

7.2 Indications of alarms and faults

The fault is indicated by indicators. For details, see section 5.3 LED keypad (BOP-270) display and operation. When the **TRIP** indicator is on, the alarm or fault code displayed on the keypad indicates the VFD is in abnormal state. This chapter covers most of the alarms and faults, and their possible causes and corrective measures. If you cannot find out the causes of alarms or faults, contact local INVT office.

7.3 Fault reset

The VFD can be reset by pressing the keypad key **STOP/RST**, digital inputs, or by cutting off the VFD power. After faults are removed, the motor can be started again.

7.4 Fault history

The function codes from P07.27 to P07.32 record the types of the last six faults. The function codes P07.33–P07.40, P07.41–P07.48, P07.49–P07.56 record the running data of VFD at the last three faults.

7.5 Faults and solutions

When a fault occurred, handle the fault as follows:

- Step 1 Check whether keypad display is improper. If yes, contact the local INVT office.
- Step 2 If keypad works properly, check the function codes in P07 group to check the fault record parameters to determine the real state when the fault occurred.
- Step 3 See the following table for a detailed solution and check for exceptions.
- Step 4 Rectify the fault or ask for help.
- Step 5 After confirming the fault is removed, perform fault reset, and start running.

7.5.1 Faults and solutions

Note: The numbers enclosed in square brackets such as [1], [2] and [3] in the Fault type column in the following table indicate the VFD fault type codes read through communication.

Fault code	Fault type	Possible cause	Solution
OU1	[1] Inverter unit	ACC is too fast.	Increase ACC time.

Fault code	Fault type	Possible cause	Solution
	U-phase protection	IGBT module is damaged.	Replace the power unit.
OUt2	[2] Inverter unit V-phase protection	Misoperation caused by interference.	Check drive wires. Check whether there is strong interference surrounding the peripheral device.
OUt3	[3] Inverter unit W-phase protection	Drive wires connected poorly. To-ground short circuit occurred.	
OV1	[7] Overvoltage during ACC	DEC time too short.	Check the input power. Check whether load DEC time is too short or the motor starts during rotating.
OV2	[8] Overvoltage during DEC	Input voltage exception. Large energy feedback.	
OV3	[9] Overvoltage during constant speed running	No braking components. Energy-consumption braking is not enabled.	Install dynamic braking components. Check the settings of related function codes.
OC1	[4] Overcurrent during ACC	ACC/DEC is too fast. Grid voltage too low.	Increase ACC/DEC time. Check the input power.
OC2	[5] Overcurrent during DEC	VFD power too small. Load transient or exception occurred.	Select a VFD with larger power. Check whether the load is short circuited (to-ground short circuit or line-to-line short circuit) or the rotation is not smooth.
OC3	[6] Overcurrent during constant speed running	To-ground short circuit or output phase loss occurred. Strong external interference sources. The overcurrent stall protection is not enabled.	Check the output wiring. Check whether there is strong interference. Check the settings of related function codes.
UV	[10] Bus undervoltage	Grid voltage too low. The overvoltage stall protection is not enabled.	Check the grid input power. Check the settings of related function codes.
OL1	[11] Motor overload	The grid voltage is too low. Motor rated current set incorrectly. The motor stall occurs or the load transient is too large.	Check the grid voltage. Reset the rated current of the motor. Check the load and adjust the torque boost quantity.
OL2	[12] VFD overload	ACC is too fast. The motor in rotating is	Increase ACC time. Avoid restart after stop.

Fault code	Fault type	Possible cause	Solution
		restarted. The grid voltage is too low. Load is too large. Power is too small.	Check the grid voltage. Select a VFD with larger power. Select a proper motor.
SPI	[13] Phase loss on input side	Phase loss or violent fluctuation occurred on input R, S, T.	Check the input power. Check the installation wiring.
SPO	[14] Phase loss on output side	Phase loss occurred to U, V, W output (or the three phases of motor is asymmetrical).	Check the output wiring. Check the motor and cables.
OH1	[15] Rectifier module overheating	Air duct blocked or fan damaged.	Ventilate the air duct or replace the fan. Lower the ambient temperature.
OH2	[16] Inverter module overheat	Ambient temperature is too high. Long-time overload running.	
EF	[17] External fault	SI external faulty input terminal action.	Check external device input.
CE	[18] RS485 communication fault	Baud rate set improperly. Communication line fault. Incorrect communication address. Communication suffers from strong interference.	Set a proper baud rate. Check the wiring of communication interfaces. Set the communication address correctly. Change or replace the wire or improve the anti-interference capability.
ItE	[19] Current detection fault	Poor contact of the connector of control board. Hall component damaged. Exception occurred to amplification circuit.	Check the connector and re-plug. Replace the hall component. Replace the main control board.
tE	[20] Motor autotuning fault	Motor capacity does not match with the VFD capacity, this fault may occur easily if the difference between them is exceeds five power	Change the VFD model, or adopt V/F mode for control. Set the proper motor type and nameplate parameters. Empty the motor load and carry out autotuning again.

Fault code	Fault type	Possible cause	Solution
		classes. Incorrect motor parameter settings. The parameters gained from autotuning deviate sharply from the standard parameters. Autotuning timeout.	Check the motor wiring and parameter settings. Check whether the upper limit frequency is larger than 2/3 of the rated frequency.
EEP	[21] EEPROM operation fault	Error in reading or writing control parameters. EEPROM damaged.	Press STOP/RST to reset. Replace the main control board.
PIDE	[22] PID feedback offline fault	PID feedback offline. PID feedback source disappears.	Check PID feedback signal wires. Check PID feedback source.
End	[24] Running time reached	The actual running time of the VFD is longer than the internal set running time.	Ask for the supplier and adjust the set running time.
OL3	[25] Electronic overload fault	The VFD reports overload pre-alarm according to the setting.	Check the load and the overload pre-alarm points.
PCE	[26] Keypad communication fault	Keypad cable connected improperly or disconnected. Keypad cable too long, causing strong interference. Circuit fault occurred to the keypad or communication part of the main board.	Check the keypad cable to determine whether a fault occurs. Check for and remove the external interference source. Replace the hardware and seek maintenance services.
UPE	[27] Parameter upload error	Keypad cable connected improperly or disconnected. Keypad cable too long, causing strong interference. Circuit fault occurred to the keypad or communication part of the main board.	Check for and remove the external interference source. Replace the hardware and seek maintenance services. Replace the hardware and seek maintenance services.

Fault code	Fault type	Possible cause	Solution
DNE	[28] Parameter download error	Keypad cable connected improperly or disconnected. Keypad cable too long, causing strong interference. Data storage error occurred to the keypad.	Check for and remove the external interference source. Replace the hardware and seek maintenance services. Re-back up the data on the keypad.
ETH1	[32] To-ground short-circuit fault 1	VFD output is short connected to the ground. There is a fault in the current detection circuit. Actual motor power setup deviates sharply from the VFD power..	Check whether the motor wiring is normal. Replace the hall component. Replace the main control board. Reset the motor parameters properly.
ETH2	[33] To-ground short-circuit fault 2	VFD output is short connected to the ground. There is a fault in the current detection circuit. Actual motor power setup deviates sharply from the VFD power..	Check whether the motor wiring is normal. Replace the hall component. Replace the main control board. Reset the motor parameters properly.
dEu	[34] Speed deviation fault	The load is too heavy or stalled.	Check and ensure the load is proper, and increase the detection time. Check whether the control parameters are set properly.
STo	[35] Mal-adjustment fault	Incorrect SM control parameter settings. Autotuned parameters are not accurate. The VFD is not connected to the motor.	Check the load and ensure the load is normal. Check whether control parameters are set correctly. Increase the mal-adjustment detection time.
LL	[36] Electronic underload fault	The VFD reports underload pre-alarm according to the setting.	Check the load and the underload pre-alarm points.
OT	[59] Motor overtemperature fault	Motor overtemperature input terminal is valid.	Check the wiring of the motor overtemperature input terminal

Fault code	Fault type	Possible cause	Solution
		The temperature detection resistance is abnormal. Long-time overload running or exception occurred.	(terminal function 57). Check whether the temperature sensor is proper. Check the motor, and perform maintenance on the motor.
E-Err	[55] Duplicate expansion card type	The two inserted expansion cards are of the same type.	You should not insert two cards with the same type. Check the type of expansion card, and remove one card after power-off.
F1-Er	[60] Failed to identify the expansion card in card slot 1	There is data transmission in the interface of card slot 1, but it cannot read the card type.	Check whether the expansion card in this slot is supported. Secure the expansion card interface after power-off, and check whether the fault persists at next power-on. Check whether the insertion port is damaged, if yes, replace the insertion port after power-off.
F2-Er	[61] Failed to identify the expansion card in card slot 2	There is data transmission in interfaces of card slot 2, however, it cannot read the card type.	Check whether the expansion card at this slot is supported. Secure the expansion card interface after power-off, and check whether the fault persists at next power-on. Check whether the insertion port is damaged, if yes, replace the insertion port after power-off.
C1-Er	[63] Communication timeout of expansion card in slot 1	There is no data transmission in interfaces of card slot 1.	Check whether the expansion card at this slot is supported. Secure the expansion card interface after power-off, and check whether the fault persists at next power-on. Check whether the insertion port is damaged, if yes, replace the insertion port after power-off.
C2-Er	[64] Communication timeout of expansion	There is no data transmission in interfaces	Check whether the expansion card at this slot is supported.

Fault code	Fault type	Possible cause	Solution
	card in slot 2	of card slot 2.	Secure the expansion card interface after power-off, and check whether the fault persists at next power-on. Check whether the insertion port is damaged, if yes, replace the insertion port after power-off.
E-DP	[29] PROFIBUS card communication timeout fault	There is no data transmission between the communication card and the host controller (or PLC).	Check whether the communication card wiring is loose or dropped.
E-NET	[30] Ethernet card communication timeout fault	There is no data transmission between the communication card and the host controller.	Check whether the communication card wiring is loose or disconnected.
E-CAN	[31] CANopen card communication timeout fault	There is no data transmission between the communication card and the host controller (or PLC).	Check whether the communication card wiring is loose or dropped.
E-PN	[57] PROFINET card communication timeout fault	There is no data transmission between the communication card and the host controller (or PLC).	Check whether the communication card wiring is loose or dropped.
E-BAC	[67] BACnet card communication timeout fault	There is no data transmission between the communication card and the host controller (or PLC).	Check whether the communication card wiring is loose or dropped.
ESCAN	[58] CAN master/slave card communication timeout fault	There is no data transmission between the CAN master and slave communication cards.	Check whether the communication card wiring is loose or dropped.
S-Err	[69] CAN slave fault in master/slave synchronization	Fault occurred to one of the CAN slave VFDs.	Detect the CAN slave VFD and analyze the corresponding fault cause of the VFD.

Fault code	Fault type	Possible cause	Solution
FrOST	[73] Freezing fault	The temperature is lower than the freezing protection threshold.	Check the temperature.
BLOCK	[74] Stalling fault	The current is greater than the stalling current.	Check for stalling.
Dr	[75] Dry pumping fault	The current is lower than the current limit for motor dry pumping.	Check for dry pumping.
STO	Safe torque off	Safe torque off function is enabled by external forces.	-
STL1	Exception occurred to safety circuit of channel 1	The wiring of STO is improper;	Check whether terminal wiring of STO is proper and firm enough;
STL2	Exception occurred to safety circuit of channel 2	Fault occurred to external switch of STO; Hardware fault occurred to safety circuit of channel.	Check whether the external switch of STO can work properly; Replace the control board. Note: Re-power on is required to remove the fault.
STL3	Exception occurred to channel 1 and channel 2	Hardware fault occurred to STO circuit.	Replace the control board.

7.5.2 Other status

Displayed code	Status type	Possible cause	Solution
PoFF	System power failure	The system is powered off or the bus voltage is too low.	Check the grid conditions.

7.6 Analysis on common faults

7.6.1 Motor fails to work

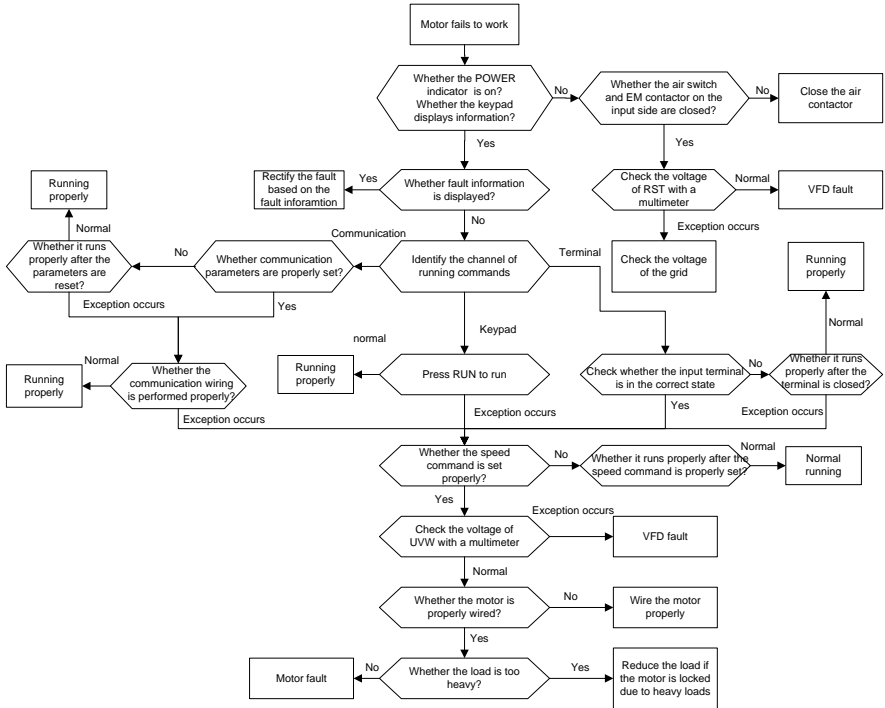

7.6.2 Motor vibrates

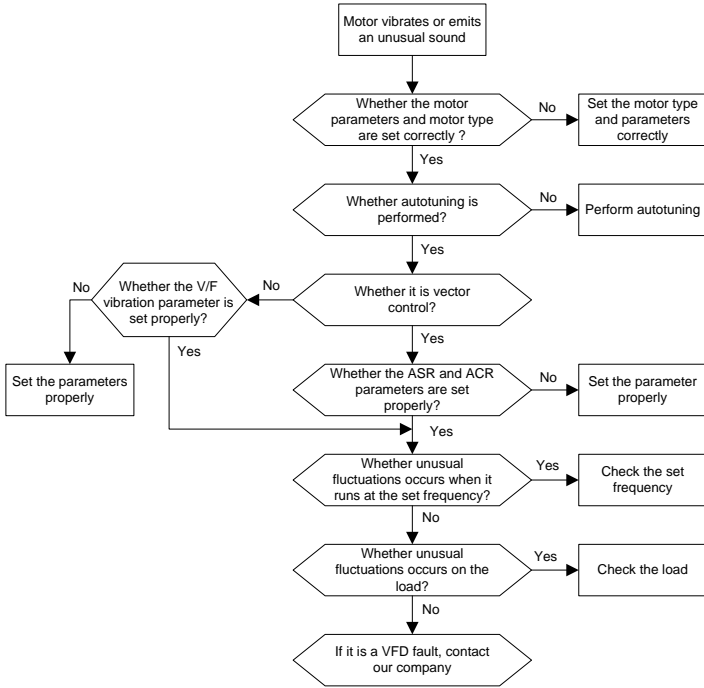

7.6.3 Overvoltage

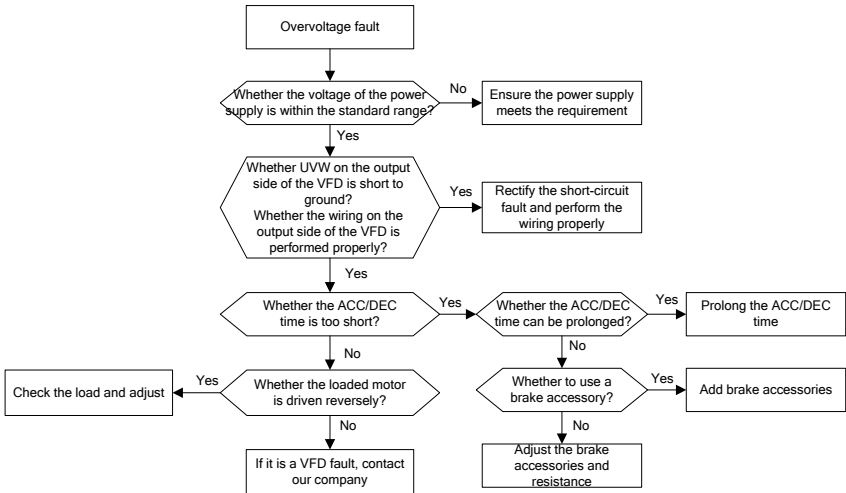

7.6.4 Undervoltage

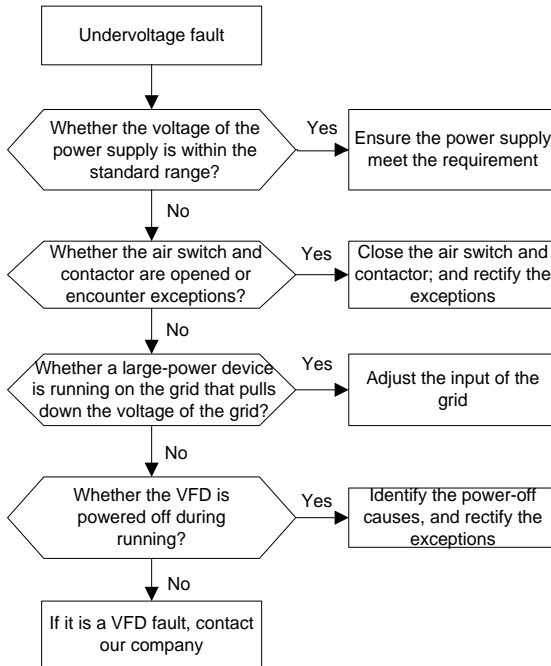

7.6.5 Motor overheating

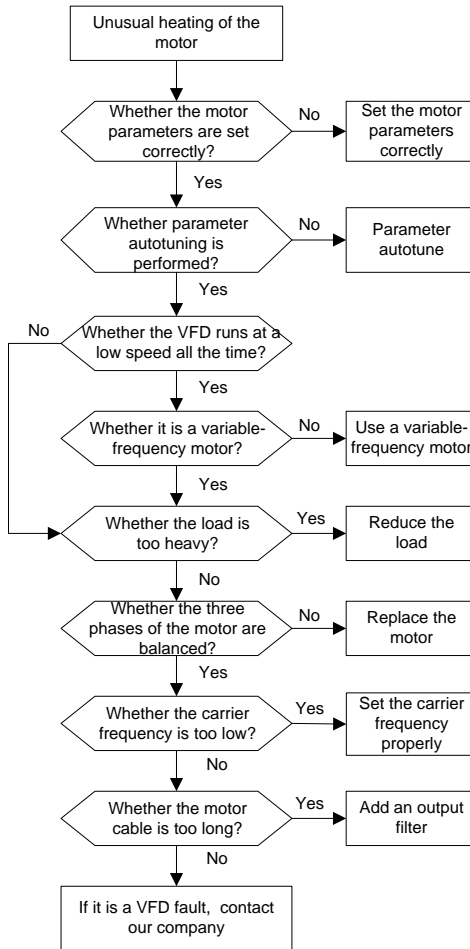

7.6.6 VFD overheating

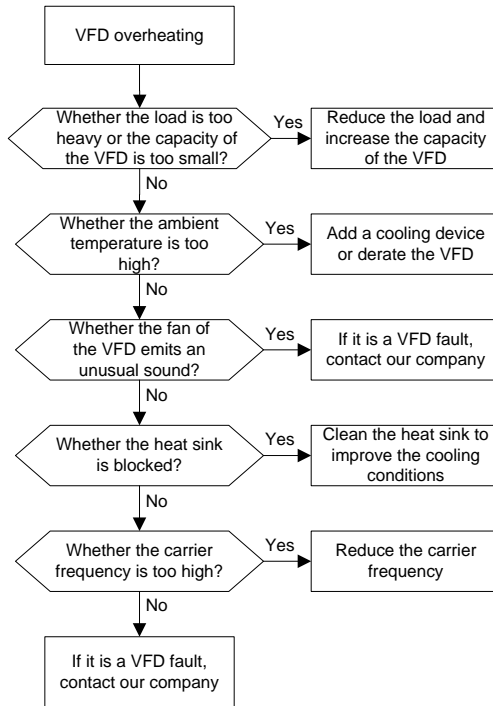

7.6.7 Motor stalls during ACC

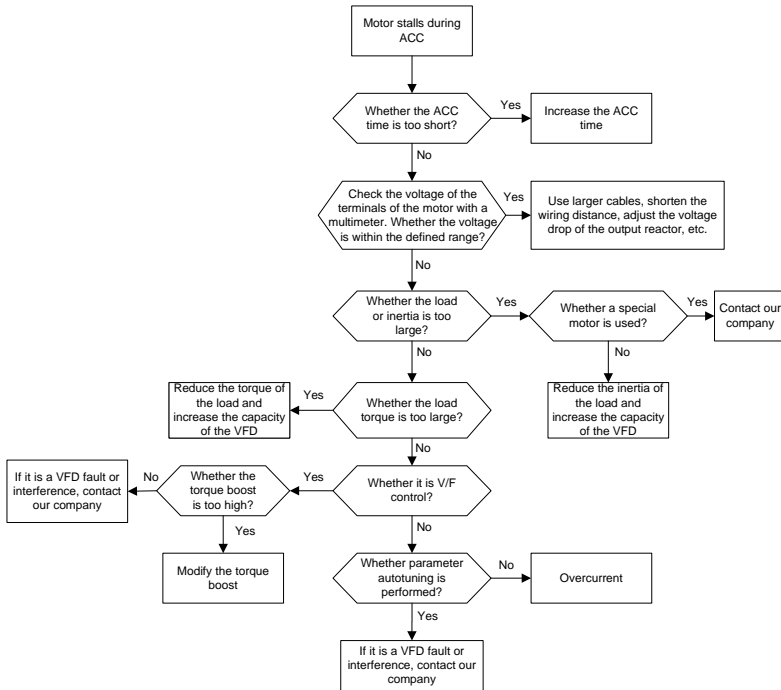

7.6.8 Overcurrent

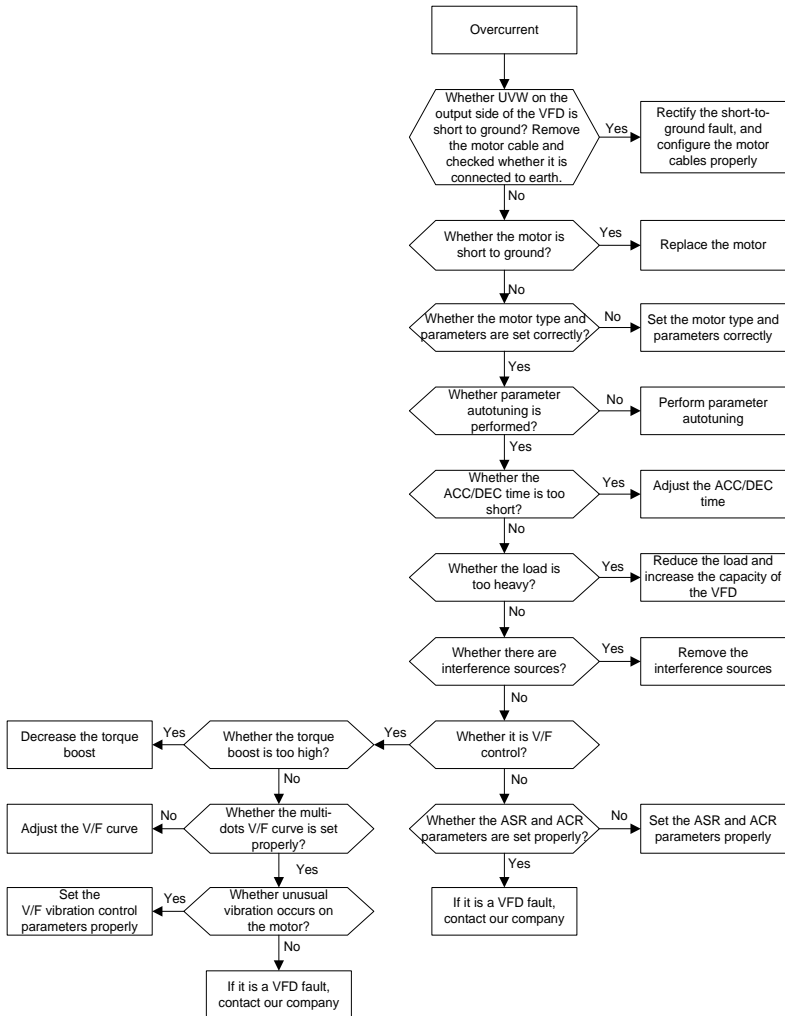

7.7 Countermeasures on common interference

7.7.1 Interference on meter switches and sensors

Interference phenomenon

Pressure, temperature, displacement, and other signals of a sensor are collected and displayed by a human-machine interaction device. The values are incorrectly displayed as follows after the VFD is started:

1. The upper or lower limit is wrongly displayed, for example, 999 or -999.
2. The display of values jumps (usually occurring on pressure transmitters).
3. The display of values is stable, but there is a large deviation, for example, the temperature is dozens of degrees higher than the common temperature (usually occurring on thermocouples).
4. A signal collected by a sensor is not displayed but functions as a drive system running feedback signal. For example, the VFD is expected to decelerate when the upper pressure limit of the compressor is reached, but in actual running, it starts to decelerate before the upper pressure limit is reached.
5. After the VFD is started, the display of all kinds of meters (such as frequency meter and current meter) that are connected to the analog output (AO) terminal of the VFD is severely affected, displaying the values incorrectly.
6. Proximity switches are used in the system. After the VFD is started, the indicator of a proximity switch flickers, and the output level flips.

Solution

1. Check and ensure that the feedback cable of the sensor is 20 cm or farther away from the motor cable.
2. Check and ensure that the ground wire of the motor is connected to the PE terminal of the VFD (if the ground wire of the motor has been connected to the ground block, you need to use a multimeter to measure and ensure that the resistance between the ground block and PE terminal is lower than 1.5 Ω).
3. Try to add a safety capacitor of 0.1 μF to the signal end of the feedback signal terminal of the sensor.
4. Try to add a safety capacitor of 0.1 μF to the power end of the sensor meter (pay attention to the voltage of the power supply and the voltage endurance of the capacitor).
5. For interference on meters connected to the AO terminal of the VFD, If AO uses 0–20mA current signal, add a capacitor of 0.47 μF between the AO and GND terminals; if AO uses 0–10V voltage signal, add a capacitor of 0.1 μF between the AO and GND terminals.

Note:

- ✧ When a decoupling capacitor is required, add it to the terminal of the device connected to the sensor. For example, if a thermocouple is to transmit signals of 0 to 20 mA to a temperature meter, the capacitor needs to be added on the terminal of the temperature meter; if an electronic ruler is to transmit signals of 0 to 30 V to a PLC signal terminal, the capacitor needs to be added on the terminal of the PLC.
- ✧ If a large number of meters or sensors are disturbed, it is recommended that you configure an external C2 filter on the VFD input power end. For details, see section D.5 Harmonic filters.

7.7.2 Interference on RS485 communication

The interference described in this section on RS485 communication mainly includes communication delay, out of synchronization, occasional power-off, or complete power-off that occurs after the VFD is started.

If the communication cannot be implemented properly, regardless of whether the VFD is running, the exception is not necessarily caused by interference. You can find out the causes as follows:

1. Check whether the RS485 communication bus is disconnected or in poor contact.
2. Check whether the two ends of line A or B are connected reversely.
3. Check whether the communication protocol of the VFD is consistent with that of the host controller. Check whether the communication protocol (such as the baud rate, data bits, and check bit) of the VFD is consistent with that of the host computer.

If you are sure that communication exceptions are caused by interference, you can resolve the problem through the following measures:

1. Simple inspection:
2. Arrange the communication cables and motor cables in different cable trays.
3. In multi-VFD application scenarios, adopt the chrysanthemum connection mode to connect the communication cables between VFDs, which can improve the anti-interference capability.
4. In multi-VFD application scenarios, check and ensure that the driving capacity of the master is sufficient.
5. In the connection of multiple VFDs, you need to configure one 120 Ω terminal resistor on each end.

Solution

1. Check and ensure that the ground wire of the motor is connected to the PE terminal of the VFD (if the ground wire of the motor has been connected to the ground block, you need to use a multimeter to measure and ensure that the resistance between the ground block and PE terminal is lower than 1.5 Ω).
2. Do not connect the VFD and motor to the same ground terminal as the host controller (PLC, HMI, and touch screen). It is recommended that you connect the VFD and motor to the power ground, and connect the host controller separately to a ground stud.
3. Try to short the signal reference ground terminal (GND) of the VFD with that of the host controller to ensure that ground potential of the communication chip on the control board of the VFD is consistent with that of the communication chip of the host controller.
4. Try to change the short-connection cap of jumper J9 on the VFD control board from 1/2 pins to 2/3 pins.
5. Try to add a safety capacitor of 0.1 μF on the power terminal of the host controller (PLC, HMI,

and touch screen). During this process, pay attention to the voltage of the power supply and the voltage endurance capability of the capacitor. Alternatively, you can use a magnet ring (Fe-based nanocrystalline magnet rings are recommended). Put the power L/N line or +/- line of the host controller through the magnet ring in the same direction and wind 8 coils around the magnet ring.

7.7.3 Failure to stop and indicator shimmering due to motor cable coupling

Interference phenomenon

1. Failure to stop

In a VFD system where an S terminal is used to control the start and stop, the motor cable and control cable are arranged in the same cable tray. After the system is started properly, the S terminal cannot be used to stop the inverter.

2. Indicator shimmering

After the VFD is started, the relay indicator, power distribution box indicator, PLC indicator, and indication buzzer shimmer, blink, or emit unusual sounds unexpectedly.

Solution

1. Check and ensure that the exception signal cable is arranged 20 cm or farther away from the motor cable.
2. Add a safety capacitor of 0.1 μF between the digital input terminal (S) and the COM terminal.
3. Connect the digital input terminal (S) that controls the start and stop to other idle digital input terminals in parallel. For example, if S1 is used to control the start and stop and S4 is idle, you can try to short connect S1 to S4 in parallel.

Note: If the controller (such as PLC) in the system controls more than 5 VFDs at the same time through digital input terminals (S), this scheme is not applicable.

7.7.4 Leakage current and interference on RCD

VFDs output high-frequency PWM voltage to drive motors. In this process, the distributed capacitance between the internal IGBT of a VFD and the heat sink and that between the stator and rotor of a motor may inevitably cause the VFD to generate high-frequency leakage current to the ground. A residual current operated protective device (RCD) is used to detect the power-frequency leakage current when a grounding fault occurs on a circuit. The application of a VFD may cause misoperation of a RCD.

1. Rules for selecting RCDs

- (1) VFD systems are special. In these systems, it is required that the rated residual current of common RCDs at all levels is larger than 200 mA, and the VFDs are grounded reliably.
- (2) For RCDs, the time limit of an action needs to be longer than that of a next action, and the time difference between two actions need to be longer than 20ms. For example, 1s, 0.5s, and 0.2s.

- (3) For circuits in VFD systems, electromagnetic RCDs are recommended. Electromagnetic RCDs have strong anti-interference capability, and thus can prevent the impact of high-frequency leakage current.

Electronic RCD	Electromagnetic RCD
Low cost, high sensitivity, small in volume, susceptible to voltage fluctuation of the grid and ambient temperature, and weak anti-interference capability	Requiring highly sensitive, accurate, and stable zero-phase sequence current transformer, using permalloy high-permeability materials, complex process, high cost, not susceptible to voltage fluctuation of the power supply and ambient temperature, strong anti- interference capability

2. Solution to RCD misoperation (handling the VFD)

- (1) Try to remove the EMC/VDR screw or J10 jumper at "EMC/VDR" of the VFD. The location of the screw or jumper is as shown in Figure 7-1 – Figure 7-8.

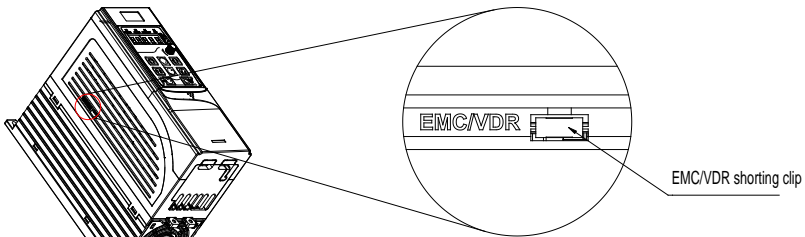

Figure 7-1 Shorting clip for 1.5–7.5kW

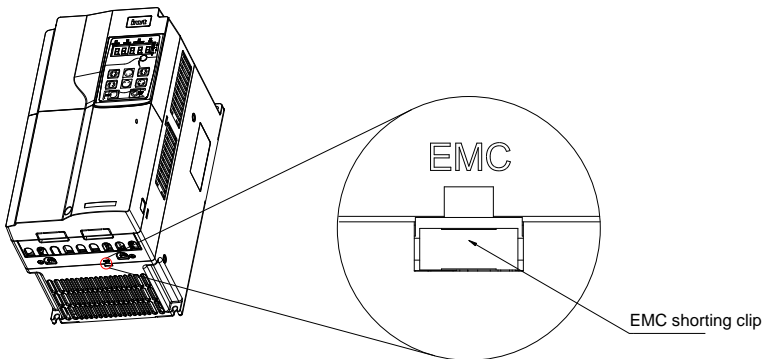

Figure 7-2 Shorting clip for 11–22kW

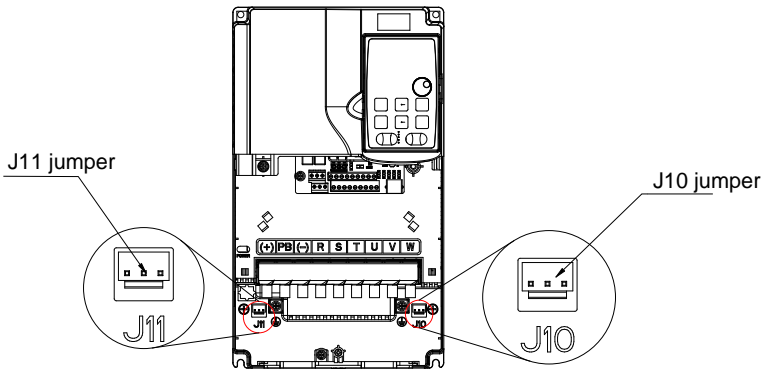

Figure 7-3 Jumper for 30–37kW (J10 for EMC; J11 for VDR)

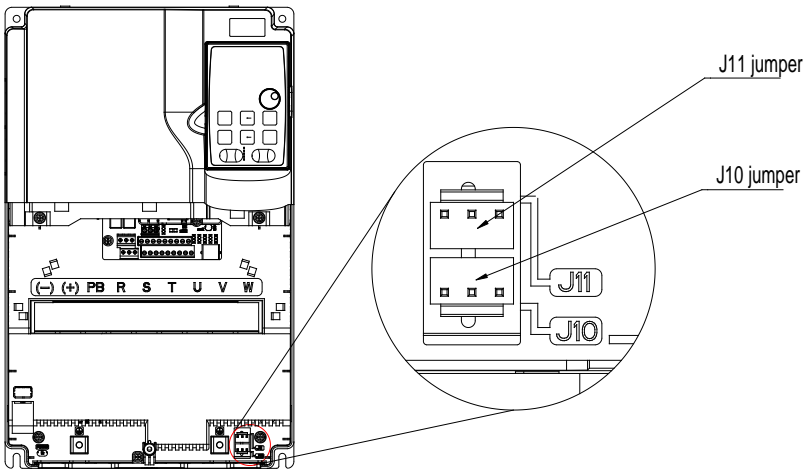

Figure 7-4 Jumper for 45kW (J10 for EMC; J11 for VDR)

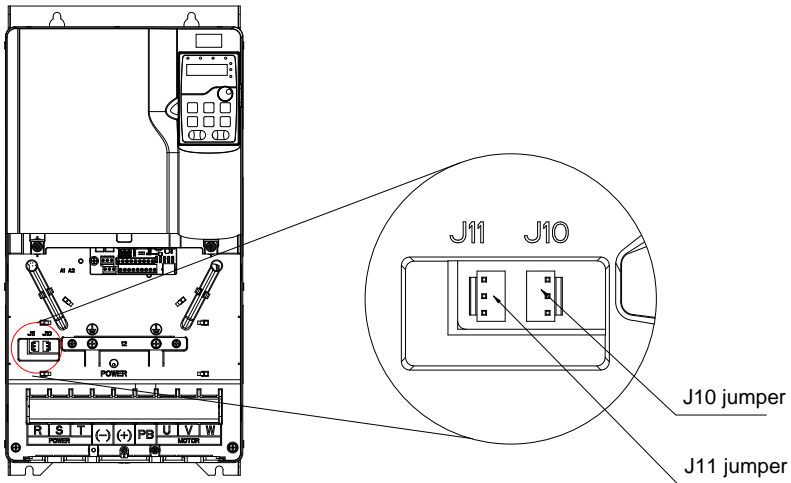

Figure 7-5 Jumper for 55–90kW (J10 for EMC; J11 for VDR)

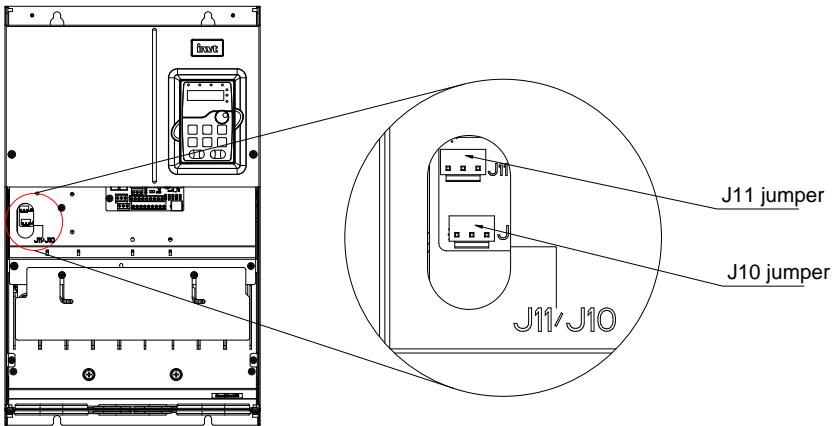

Figure 7-6 Jumper for 110–132kW (J10 for EMC; J11 for VDR)

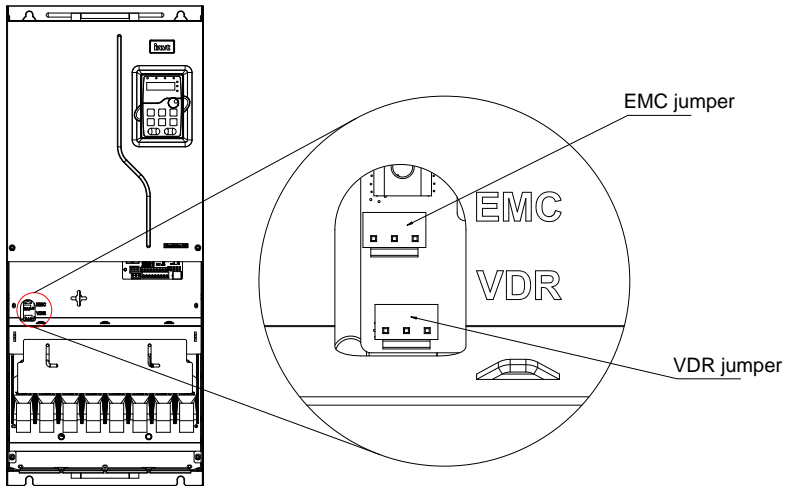

Figure 7-7 Jumper for 160–200kW

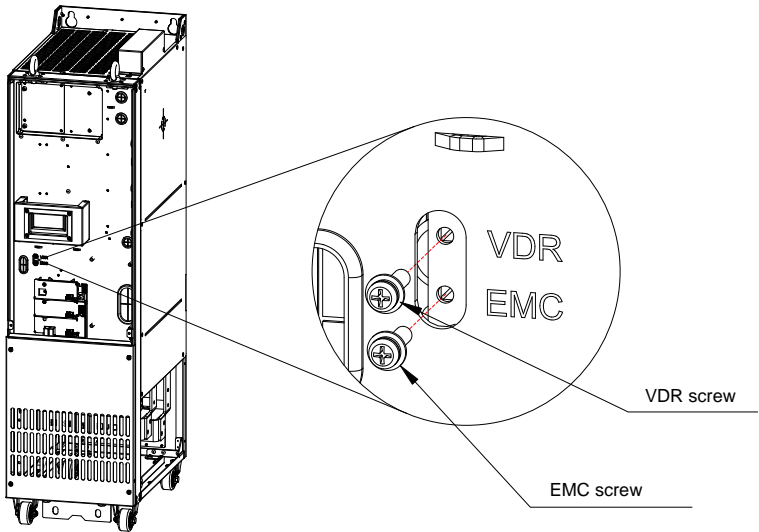

Figure 7-8 Screw positions for 220–630kW

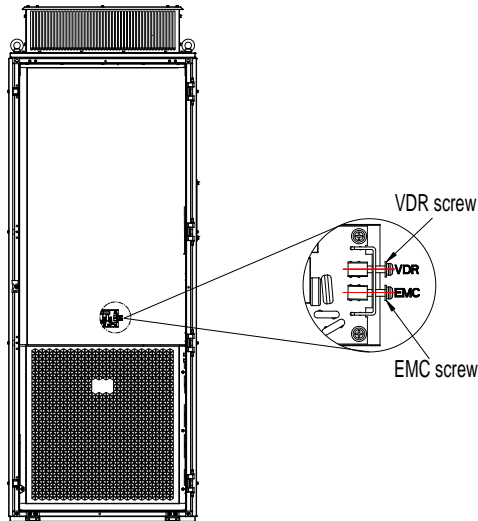

Figure 7-9 Screw positions for 710–800kW

- (2) Try to decrease the carrier frequency to 1.5kHz (P00.14=1.5).
- (3) Try to modify the modulation method to "3PH modulation and 2PH modulation" (P08.40=00).
3. Solution to mal-operation of RCD (on the part of system distribution)
 - (1) Check and ensure that the power cable is not soaking in water.
 - (2) Check and ensure that the cables are not damaged or spliced.
 - (3) Check and ensure that no secondary grounding is performed on the neutral wire.
 - (4) Check and ensure that the main power cable terminal is in good contact with the air switch or contactor (all screws are tightened).
 - (5) Check 1PH powered devices, and ensure that no earth lines are used as neutral wires by these devices.
 - (6) Do not use shielded cables as VFD power cables and motor cables.

7.7.5 Live device chassis

After the VFD is started, there is sensible voltage on the chassis, and you may feel an electric shock when touching the chassis. The chassis, however, is not live (or the voltage is far lower than the human safety voltage) when the VFD is powered on but not running.

Solution

1. If there is power distribution grounding or ground stud on the site, ground the cabinet chassis of the VFD through the power ground or stud.
2. If there is no grounding on the site, you need to connect the motor casing to the VFD grounding terminal PE, and ensure that the jumper at "EMC/VDR" of the VFD is shorted.

8 Maintenance

8.1 What this chapter contains

This chapter describes how to carry out preventive maintenance on the VFD.

8.2 Periodical maintenance

Little maintenance is required when the VFD is installed in an environment that meets requirements.

The following table describes the routine maintenance periods recommended by INVT. The following table describes the routine maintenance periods recommended by INVT.

Check scope		Check item	Method	Expected result
Ambient environment		Check the temperature, and humidity, and whether there is vibration, dust, gas, oil spray, and water droplets in the environment.	Visual inspection and instrument measurement	The requirements stated in this manual are met.
		Check whether there are foreign matters, such as tools, or dangerous substances placed nearby.	Visual inspection	There are no tools or dangerous substances placed nearby.
Voltage		Check the voltage of the main circuit and control circuit.	Use multimeters or other instruments for measurement.	The requirements stated in this manual are met.
Keypad		Check the display of information.	Visual inspection	The characters are displayed properly.
		Check whether characters are not completely displayed.	Visual inspection	The requirements stated in this manual are met.
Main circuit	Common	Check whether bolts are loose or fall off.	Screw them up.	No exception occurs.
		Check whether the machine is deformed, cracked, or damaged, or their color changes due to overheating and aging.	Visual inspection	No exception occurs.
		Check whether there are stains and dust attached.	Visual inspection	No exception occurs. Note: Discoloration of copper bars does not mean that they cannot work properly.

Check scope	Check item	Method	Expected result
Conductor and wire	Check whether conductors are deformed or color change for overheat.	Visual inspection	No exception occurs.
	Check whether the wire sheaths are cracked or their color changes.	Visual inspection	No exception occurs.
Terminal block	Check whether there is damage.	Visual inspection	No exception occurs.
Filter capacitor	Check whether there is electrolyte leakage, discoloration, cracks, and chassis expansion.	Visual inspection	No exception occurs.
	Check whether the safety valves are released.	Determine the service life based on the maintenance information, or measure them through electrostatic capacity.	No exception occurs.
	Check whether the electrostatic capacity is measured as required.	Use instruments to measure the capacity.	Electrostatic capacity \geq (Initial value \times 0.85)
Resistor	Check whether there is displacement caused due to overheat.	Olfactory and visual inspection	No exception occurs.
	Check whether the resistors are disconnected.	Visual inspection, or remove one end of the connection cable and use a multimeter for measurement.	Resistance range: $\pm 10\%$ (of the standard resistance)
Transformer, Reactor	Check whether there is unusual vibration sounds or smells.	Auditory, olfactory, and visual inspection	No exception occurs.

Check scope		Check item	Method	Expected result
	Electromagnetic contactor and Relay	Check whether there are vibration sounds in the workshop.	Auditory inspection	No exception occurs.
		Check whether the contacts are in good contact.	Visual inspection	No exception occurs.
Control circuit	Control PCB and connector	Check whether the screws and connectors are loose.	Screw them up.	No exception occurs.
		Check whether there is unusual smell or discoloration.	Olfactory and visual inspection	No exception occurs.
		Check whether there are cracks, damage, deformation, or rust.	Visual inspection	No exception occurs.
		Check whether there is electrolyte leakage or deformation.	Visual inspection, and determine the service life based on the maintenance information.	No exception occurs.
Cooling system	Cooling fan	Check whether there are unusual sounds or vibration.	Auditory and visual inspection, and turn the fan blades with your hand.	The rotation is smooth.
		Check whether the bolts loose.	Screw them up.	No exception occurs.
		Check whether there is decoloration caused due to overheat.	Visual inspection, and determine the service life based on the maintenance information.	No exception occurs.
	Ventilation duct	Check whether there are foreign matters blocking or attached to the cooling fan, air inlets, or air outlets. Check whether there are foreign objects attached.	Visual inspection	No exception occurs.

For more details about maintenance, contact the local INVT office, or visit our website www.invt.com, and choose **Support > Services**.

8.3 Cooling fan

The service life of the cooling fan of the VFD is more than 25,000 hours. The actual service life of the cooling fan is related to the use of the VFD and the temperature in the ambient environment.

You can view the running duration of the VFD through P07.14 (Accumulated running time).

The increase of the bearing noise indicates a fan fault. If the VFD is applied in a key position, replace the fan once the fan starts to generate unusual noise. You can purchase spares of fans from INVT.



Read chapter 1 Safety precautions carefully and follow the instructions to perform operations. Ignoring these safety precautions may lead to physical injury or death, or device damage.

To replace the cooling fan for 2.2–630kW models:

Step 1 Stop the VFD, disconnect the AC power supply, and wait for a time no shorter than the waiting time designated on the VFD.

Step 2 Open the cable clamp to loose the fan cable.

Step 3 Disconnect the fan cable.

Step 4 Remove the fan with a screwdriver.

Step 5 Install a new fan in the VFD in the reverse steps. Assemble the VFD. Ensure that the air direction of the fan is consistent with that of the VFD, as shown in the following figure.

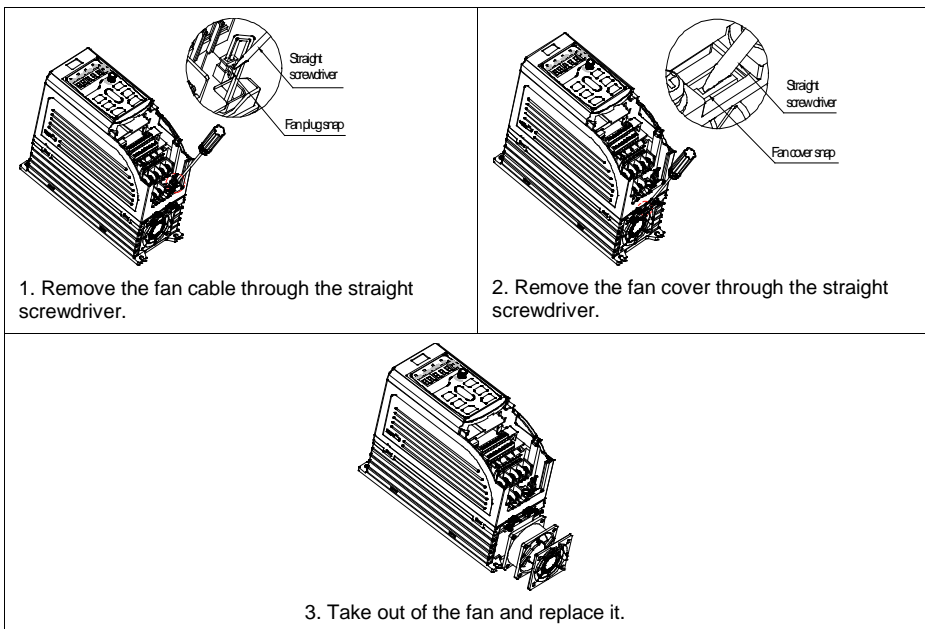

Figure 8-1 Fan maintenance for 2.2–7.5kW VFD models (disassembly with tools)

Note: The GD270-1R5-4 model is a fanless natural cooling design that requires no fan maintenance.

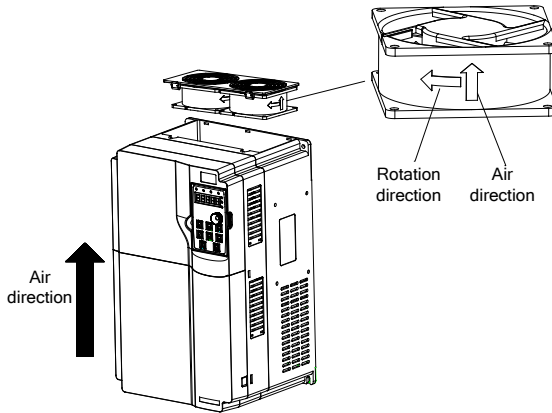

Figure 8-2 Fan maintenance for 11–200kW VFD models

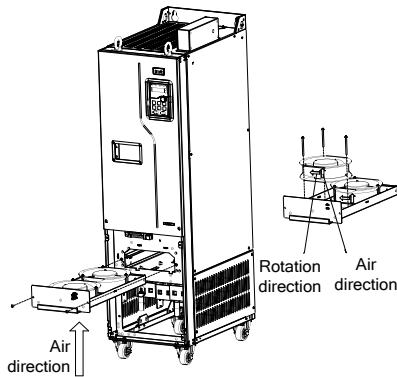

Figure 8-3 Fan maintenance for the 220–630kW VFD models

Step 6 Connect to the power supply.

The 710–800kW cabinet unit features two types of cooling fans: top-mounted fans and phase unit internal fans. The replacement procedures for each are described below.

To replace the top cooling fan:

Step 1 Stop the VFD, disconnect the AC power supply, and wait for a time no shorter than the waiting time designated on the VFD.

Step 2 Open the cable clamp to lose the fan cable.

- Step 3 Use a screwdriver to remove the four screws securing the fan box, and then take out the fan box assembly.
- Step 4 Use a screwdriver to remove the four screws securing the fan, and then remove the fan.
- Step 5 Install a new fan in the VFD in the reverse steps. Assemble the VFD. Ensure that the air direction of the fan is consistent with that of the VFD, as shown in the following figure.

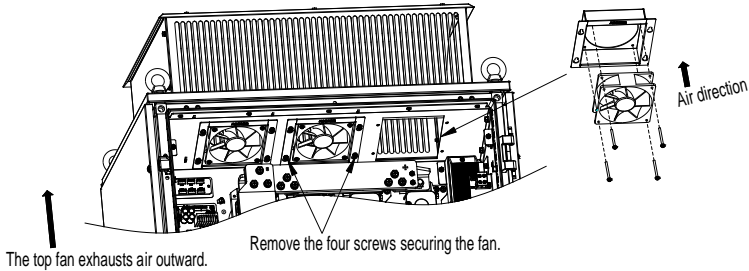

- Step 6 Connect the power supply.

To replace the phase unit internal fan:

- Step 1 Stop the VFD, disconnect the AC power supply, and wait for a time no shorter than the waiting time designated on the VFD.
- Step 2 Open the cable clamp to loose the fan cable.
- Step 3 Use a screwdriver to remove the front connector bar from the fan box (see figure below).

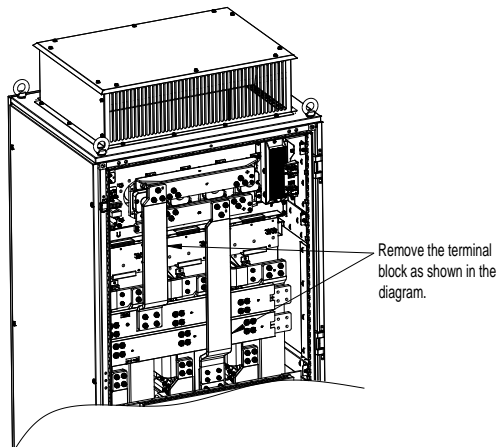

- Step 4 Use a screwdriver to remove the five screws securing the fan box, then take out the fan box assembly.

Step 5 Use a screwdriver to remove the eight screws securing the fan, then remove the fan as shown in the following figure.

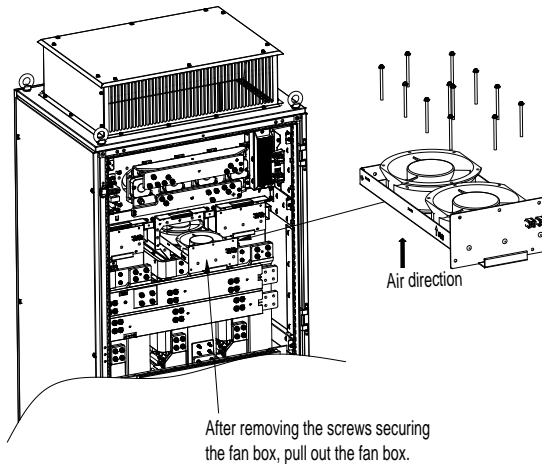

Step 6 Install a new fan in the VFD in the reverse steps. Assemble the VFD. Ensure that the air direction of the fan is consistent with that of the VFD.

Step 7 Connect the power supply.

8.4 Capacitor

8.4.1 Capacitor reforming

If the VFD has been left unused for a long time, you need to follow the instructions to reform the DC bus capacitor before using it. The storage time is calculated from the date the VFD is delivered.

Storage time	Operation principle
Less than 1 year	No charging operation is required.
1 to 2 years	The VFD needs to be powered on for 1 hour before the first running command.
2 to 3 years	Use a voltage controlled power supply to charge the VFD: <ul style="list-style-type: none"> ● Charge the VFD at 25% of the rated voltage for 30 minutes, ● and then charge it at 50% of the rated voltage for 30 minutes, ● at 75% for another 30 minutes, ● and finally charge it at 100% of the rated voltage for 30 minutes.
More than 3 years	Use a voltage controlled power supply to charge the VFD: <ul style="list-style-type: none"> ● Charge the VFD at 25% of the rated voltage for 2 hours, ● and then charge it at 50% of the rated voltage for 2 hours, ● at 75% for another 2 hours, ● and finally charge it at 100% of the rated voltage for 2 hours.

The method for using a voltage controlled power supply to charge the VFD is described as follows:

The selection of a voltage controlled power supply depends on the power supply of the VFD. For VFDs with an incoming voltage of 1PH/3PH 230V AC, you can use a 1PH 230V AC/2 A voltage regulator. Both 1PH and 3PH VFDs can be charged with a 1PH voltage controlled power supply (connect L+ to R, and N to S or T). All the DC bus capacitors share one rectifier, and therefore they are all charged.

For VFDs of a high voltage class, ensure that the voltage requirement (for example, 380 V) is met during charging. Capacitor charging requires little current, and therefore you can use a small-capacity power supply (2 A is sufficient).

The method for using a resistor (incandescent lamp) to charge the drive is described as follows:

If you directly connect the drive device to a power supply to charge the DC bus capacitor, it needs to be charged for a minimum of 60 minutes. The charging operation must be performed at a normal indoor temperature without load, and you must connect a resistor in series mode in the 3PH circuit of the power supply.

For a 380 V drive device, use a resistor of 1 kΩ/100W. If the voltage of the power supply is no higher than 380 V, you can also use an incandescent lamp of 100W. If an incandescent lamp is used, it may go off or the light may become very weak.



Figure 8-4 380V drive device charging circuit example

8.4.2 Electrolytic capacitor replacement



Read chapter 1 Safety precautions carefully and follow the instructions to perform operations. Ignoring these safety precautions may lead to physical injury or death, or device damage.

The electrolytic capacitor of a VFD must be replaced if it has been used for more than 35,000 hours. For details about the replacement, contact the local INVT office.

8.5 Power cable



Read chapter 1 Safety precautions carefully and follow the instructions to perform operations. Ignoring these safety precautions may lead to physical injury or death, or device damage.

1. Stop the VFD, disconnect the power supply, and wait for a time no shorter than the waiting time designated on the VFD.
2. Check the connection of the power cables. Ensure that they are firmly connected.
3. Connect to the power.

9 Communication protocol

9.1 What this chapter contains

This chapter describes the communication of the VFD.

The VFD provides RS485 communication interfaces and adopts the master-slave communication based on the international standard Modbus communication protocol. You can implement centralized control (setting commands for controlling the VFD, modifying the running frequency and related function code parameters, and monitoring the working state and fault information of the VFD) through PC/PLC, upper control computer, or other devices to meet specific application requirements.

9.2 Modbus protocol introduction

Modbus is a communication protocol for use with electronic controllers. By using this protocol, a controller can communicate with other devices through transmission lines. It is a general industrial standard. With this standard, control devices produced by different manufacturers can be connected to form an industrial network and be monitored in a centralized way.

The Modbus protocol provides two transmission modes, namely American Standard Code for Information Interchange (ASCII) and remote terminal units (RTU). On one Modbus network, all the device transmission modes, baud rates, data bits, check bits, stop bits, and other basic parameters must be set consistently.

A Modbus network is a control network with one master and multiple slaves, that is, on one Modbus network, there is only one device serving as the master, and other devices are the slaves. The master can communicate with any single slave or with all slaves. For separate access commands, a slave needs to return a response. For broadcasted information, slaves do not need to return responses.

9.3 Application of Modbus

The VFD uses the Modbus RTU mode and communicates through RS485 interfaces.

9.3.1 RS485

RS485 interfaces work in half-duplex mode and transmit data signals in the differential transmission way, which is also referred to as balanced transmission. An RS485 interface uses a twisted pair, where one wire is defined as A (+), and the other B (-). Generally, if the positive electrical level between the transmission drives A and B ranges from +2V to +6V, the logic is "1"; and if it ranges from -6V to -2V, the logic is "0".

The 485+ terminal on the terminal block of the VFD corresponds to A, and 485- corresponds to B.

The communication baud rate (P14.01) indicates the number of bits sent in a second, and the unit Bit/s(bps). A higher baud rate indicates faster transmission and poorer anti-interference capability. When a twisted pair of 0.56mm (24 AWG) is used, the maximum transmission distance varies according to the baud rate, as described in the following table.

Baud rate	Max. transmission distance	Baud rate	Max. transmission distance
2400bps	1800m	9600bps	800m
4800bps	1200m	19200bps	600m

In long-distance RS485 communication, it is recommended that you use shielded cables, and use the shielding layer as the ground wire.

When there are fewer devices and the transmission distance is short, the whole network works well without terminal load resistors. The performance, however, degrades as the distance increases. Therefore, it is recommended that you use a 120Ω terminal resistor when the transmission distance is long.

9.3.1.1 Application to one VFD

Figure 9-1 is the Modbus wiring diagram of one VFD and a PC. Generally, PCs do not provide RS485 interfaces, so you need to convert an RS232 or USB interface of a PC to an RS485 interface through an adapter. Connect end A of the RS485 interface to the 485+ port on the terminal block of the VFD, and connect end B to the 485- port. It is recommended that you use shielded twisted pairs. When an RS232-RS485 adapter is used, the cable used to connect the RS232 interface of the PC and the adapter cannot be longer than 15m. Use a short cable when possible. It is recommended that you insert the adapter directly into the PC. Similarly, when a USB-RS485 converter is used, use a short cable when possible.

After wiring, select the correct port (such as COM1 to connect the RS232-RS485 converter) on the host controller, and set the basic parameters such as baud rate and data bit check consistent with those of the VFD.

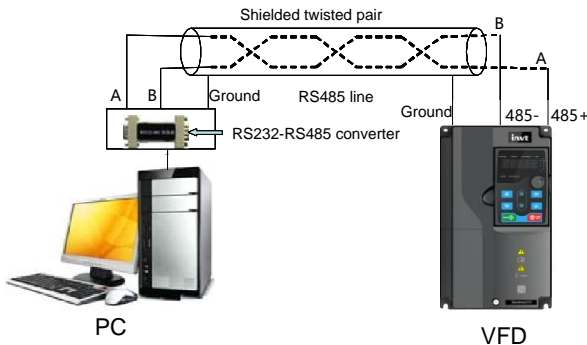

Figure 9-1 RS485 wiring of one VFD

9.3.1.2 Application to multiple VFDs

In practical application to multiple VFDs, chrysanthemum connection and star connection are commonly used.

According to the requirements of the RS485 industrial bus standards, all the devices need to be connected in chrysanthemum mode with one 120Ω terminal resistor on each end, as shown in Figure 9-2. Figure 9-3 is the simplified wiring diagram, and Figure 9-4 is the practical application diagram.

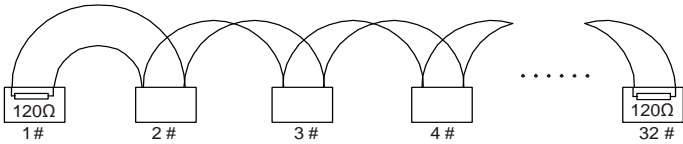

Figure 9-2 Onsite chrysanthemum connection

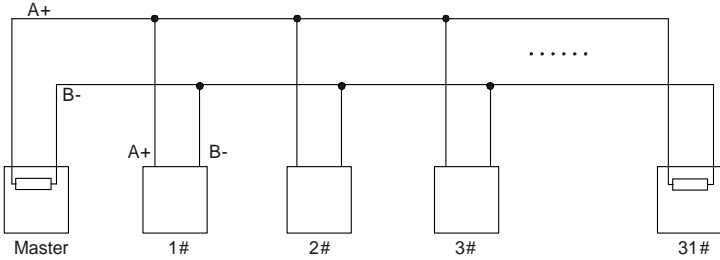

Figure 9-3 Simplified chrysanthemum connection

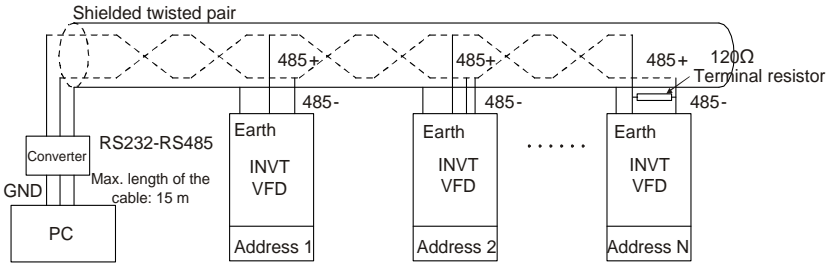

Figure 9-4 Practical chrysanthemum connection application

Figure 9-5 shows the start connection diagram. When this connection mode is adopted, each of the two devices that are farthest away from each other on the line must be configured with a terminal resistor (in Figure 9-5, the two devices are devices 1# and 15#).

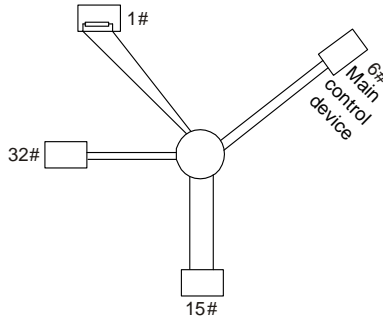

Figure 9-5 Star connection

Use shielded cables, if possible, in multi-device connection. The baud rates, data bit check settings, and other basic parameters of all the devices on the RS485 line must be set consistently, and addresses cannot be repeated.

9.3.2 RTU mode

9.3.2.1 RTU communication frame structure

When a controller is set to use the RTU communication mode on a Modbus network, every byte (8 bits) in the message includes 2 hexadecimal characters (each includes 4 bits). Compared with the ASCII mode, the RTU mode achieves transmission of more data at the same baud rate.

Code system

- 1 start bit
- 7 or 8 data bits; the minimum valid bit is transmitted first. Each frame domain of 8 bits includes 2 hexadecimal characters (0–9, A–F).
- 1 odd/even check bit; this bit is not provided if no check is needed.
- 1 stop bit (with check performed), 2 bits (without check)

Error detection domain

- Cyclic redundancy check (CRC)

The following table describes the data format.

11-bit frame (bits 1 to 8 are data bits):

Start bit	Bit1	Bit2	Bit3	Bit4	Bit5	Bit6	Bit7	Bit8	Check bit	Stop bit
-----------	------	------	------	------	------	------	------	------	-----------	----------

10-bit character frame (bits 1 to 7 are data bits):

Start bit	Bit1	Bit2	Bit3	Bit4	Bit5	Bit6	Bit7	Check bit	Stop bit
-----------	------	------	------	------	------	------	------	-----------	----------

In a character frame, only the data bits carry information. The start bit, check bit, and end bit are used to facilitate the transmission of the data bits to the destination device. In practical applications, you must set the data bits, parity check bits, and stop bits consistently.

In RTU mode, the transmission of a new frame always starts from an idle time (the transmission time of 3.5 bytes). On a network where the transmission rate is calculated based on the baud rate, the transmission time of 3.5 bytes can be easily obtained. After the idle time ends, the data domains are transmitted in the following sequence: slave address, operation command code, data, and CRC check character. Each byte sent in each domain includes 2 hexadecimal characters (0–9, A–F). The network devices always monitor the communication bus. After receiving the first domain (address information), each network device identifies the byte. After the last byte is sent, a similar transmission interval (with a minimum transmission time of 3.5 bytes) is used to indicate that the frame transmission ends. Then, the transmission of a new frame starts.

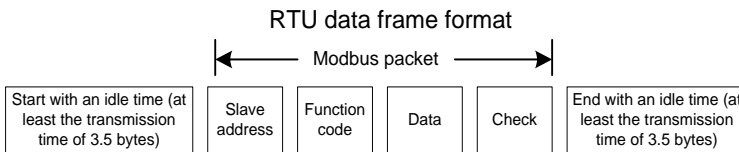

The information of a frame must be transmitted in a continuous data flow. If there is an interval greater than the transmission time of 1.5 bytes before the transmission of the entire frame is complete, the receiving device deletes the incomplete information, and mistakes the subsequent byte for the address domain of a new frame. Similarly, if the transmission interval between two frames is shorter than the transmission time of 3.5 bytes, the receiving device mistakes it for the data of the last frame. The CRC check value is incorrect due to the disorder of the frames, and thus a communication fault occurs.

The following table describes the standard structure of an RTU frame.

START (frame header)	T1-T2-T3-T4 (time gap with a min. length of 3.5 bytes)
ADDR (slave address domain)	Communication address: 0–247 (decimal system) (0 is the broadcast address)
CMD (function domain)	03H: read slave parameters 06H: write slave parameters
Data domain DATA (N-1) ...DATA (0)	Data of 2*N bytes, main content of the communication as well as the core of data exchanging.
CRC CHK LSB	Detection value: CRC verification value (16 bits)
CRC CHK MSB	
END (frame tail)	T1-T2-T3-T4 (time gap with a min. length of 3.5 bytes)

9.3.2.2 RTU communication frame error check modes

During the transmission of data, errors may occur due to various factors. Without error check, the data receiving device cannot identify data errors and may make an incorrect response. The incorrect response may cause severe problems. Therefore, the data must be checked.

The check is implemented as follows: The transmitter calculates the to-be-transmitted data based on a specific algorithm to obtain a result, adds the result to the rear of the message, and transmits them together. After receiving the message, the receiver calculates the data based on the same algorithm to obtain a result, and compares the result with that transmitted by the transmitter. If the results are the same, the message is correct. Otherwise, the message is considered incorrect.

The error check of a frame includes two parts, namely, bit check on individual bytes (that is, odd/even check using the check bit in the character frame), and whole data check (CRC check).

Bit check on individual bytes (odd/even check)

You can select the bit check mode as required, or you can choose not to perform the check, which will affect the check bit setting of each byte.

Definition of even check: Before the data is transmitted, an even check bit is added to indicate whether the number of "1" in the to-be-transmitted data is odd or even. If it is even, the check bit is set to "0"; and if it is odd, the check bit is set to "1".

Definition of odd check: Before the data is transmitted, an odd check bit is added to indicate whether the number of "1" in the to-be-transmitted data is odd or even. If it is odd, the check bit is set to "0"; and if it is even, the check bit is set to "1".

For example, the data bits to be sent are "11001110", including five "1". If the even check is applied, the even check bit is set to "1"; and if the odd check is applied, the odd check bit is set to "0". During the transmission of the data, the odd/even check bit is calculated and placed in the check bit of the frame. The receiving device performs the odd/even check after receiving the data. If it finds that the odd/even parity of the data is inconsistent with the preset information, it determines that a communication error occurs.

CRC

A frame in the RTU format includes an error detection domain based on the CRC calculation. The CRC domain checks all the content of the frame. The CRC domain consists of two bytes, including 16 binary bits. It is calculated by the transmitter and added to the frame. The receiver calculates the CRC of the received frame, and compares the result with the value in the received CRC domain. If the two CRC values are not equal to each other, errors occur in the transmission.

During CRC, 0xFFFF is stored first, and then a process is invoked to process a minimum of 6 contiguous bytes in the frame based on the content in the current register. CRC is valid only for the 8-bit data in each character. It is invalid for the start, stop, and check bits.

During the generation of the CRC values, the "exclusive or" (XOR) operation is performed on the each 8-bit character and the content in the register. The result is placed in the bits from the least

significant bit (LSB) to the most significant bit (MSB), and 0 is placed in the MSB. Then, LSB is detected. If LSB is 1, the XOR operation is performed on the current value in the register and the preset value. If LSB is 0, no operation is performed. This process is repeated 8 times. After the last bit (8th bit) is detected and processed, the XOR operation is performed on the next 8-bit byte and the current content in the register. The final values in the register are the CRC values obtained after operations are performed on all the bytes in the frame.

The calculation adopts the international standard CRC check rule. You can refer to the related standard CRC algorithm to compile the CRC calculation program as required.

The following example is a simple CRC calculation function for your reference (using the C programming language):

```
unsigned int crc_cal_value (unsigned char*data_value,unsigned char data_length)
{
    int i;
    unsigned int crc_value=0xffff;
    while (data_length--)
    {
        crc_value^=*data_value++;
        for (i=0;i<8;i++)
        {
            if (crc_value&0x0001)
                crc_value= (crc_value>>1) ^0xa001;
            else
                crc_value=crc_value>>1;
        }
    }
    Return (crc_value);
}
```

In the ladder logic, CKSM uses the table look-up method to calculate the CRC value according to the content in the frame. The program of this method is simple, and the calculation is fast, but the ROM space occupied is large. Use this program with caution in scenarios where there are space occupation requirements on programs.

9.4 RTU command codes and communication data

9.4.1 Command code 03H, reading N words (continuously up to 16 words)

The command code 03H is used by the master to read data from the VFD. The count of data to be read depends on the "data count" in the command. A maximum of 16 pieces of data can be read. The addresses of the read parameters must be contiguous. Each piece of data occupies 2 bytes, that is, one word. The command format is presented using the hexadecimal system (a number followed by "H" indicates a hexadecimal value). One hexadecimal value occupies one byte.

The 03H command is used to read information including the parameters and running status of the VFD.

For example, to read two contiguous data content pieces from 0004H from the VFD with the address of 01H (that is, to read content from data addresses 0004H and 0005H), the frame structure is as follows:

RTU master command (from the master to the VFD)

START	T1-T2-T3-T4 (transmission time of 3.5 bytes)
ADDR (address)	01H
CMD (command code)	03H
Start address MSB	00H
Start address LSB	04H
Data count MSB	00H
Data count LSB	02H
CRC LSB	85H
CRC MSB	CAH
End	T1-T2-T3-T4 (transmission time of 3.5 bytes)

The value in START and END is "T1-T2-T3-T4 (transmission time of 3.5 bytes)", indicating that the RS485 needs to stay idle for at least the transmission time of 3.5 bytes. An idle time is required to distinguish on message from another to ensure that the two messages are not regarded as one.

"ADDR" is "01H", indicating that the command is sent to the VFD whose address is 01 H. "ADDR" occupies one byte.

"CMD" is "03H", indicating that the command is used to read data from the VFD. The CMD information occupies one byte.

"Start address" means the address from which data reading starts. and it occupies two bytes with the MSB on the left and LSB on the right.

"Data count" indicates the count of data to be read (unit: word). "Start address" is "0004H" and "Data count" is 0002H, indicating that data is to be read from the data addresses of 0004H and 0005H.

CRC check occupies two bytes, with the LSB on the left, and MSB on the right.

RTU slave response (from the VFD to the master)

START	T1-T2-T3-T4 (time gap with a min. length of 3.5 bytes)
ADDR	01H
CMD	03H
Number of bytes	04H
Address 0004H data MSB	13H
Address 0004H data LSB	88H
Address 0005H data MSB	00H
Address 0005H data LSB	00H
CRC LSB	7EH
CRC MSB	9DH
End	T1-T2-T3-T4 (time gap with a min. length of 3.5 bytes)

The definition of the response information is described as follows:

"ADDR" is "01H", indicating that the message is sent by the VFD whose address is 01H. The ADDR

information occupies one byte.

"CMD" is "03H", indicating that the message is a response of the VFD to the 03H command of the master for reading data. The CMD information occupies one byte.

"Number of bytes" indicates the number of bytes between a byte (not included) and the CRC byte (not included). The value "04" indicates that there are four bytes of data between "Number of bytes" and "CRC LSB", that is, "MSB of data in 0004H", "LSB of data in 0004H", "MSB of data in 0005H", and "LSB of data in 0005H".

A piece of data contains two bytes, with the MSB on the left and LSB on the right. From the response, the data in 0004H is 1388H, and that in 0005H is 0000H.

CRC check occupies two bytes, with the LSB on the left, and MSB on the right.

9.4.2 Command code 06H, writing a word

This command is used by the master to write data to the VFD. One command can be used to write only one piece of data. It is used to modify the parameters and running mode of the VFD.

For example, if the master writes 5000 (1388H) to 0004H of the VFD whose address is 02H, the frame structure is as follows.

RTU master command (from the master to the VFD)

START	T1-T2-T3-T4 (time gap with a min. length of 3.5 bytes)
ADDR	02H
CMD	06H
MSB of data writing address	00H
LSB of data writing address	04H
Data content MSB	13H
Data content LSB	88H
CRC LSB	C5H
CRC MSB	6EH
End	T1-T2-T3-T4 (time gap with a min. length of 3.5 bytes)

RTU slave response (from the VFD to the master)

START	T1-T2-T3-T4 (time gap with a min. length of 3.5 bytes)
ADDR	02H
CMD	06H
MSB of data writing address	00H
LSB of data writing address	04H
Data content MSB	13H
Data content LSB	88H
CRC LSB	C5H
CRC MSB	6EH
End	T1-T2-T3-T4 (time gap with a min. length of 3.5 bytes)

Note: The sections 9.4.1 and 9.4.2 mainly describe the command formats. For the detailed application, see the examples in section 9.4.7.

9.4.3 Command code 10H, continuous writing

The command code 10H is used by the master to write data to the VFD. The quantity of data to be written is determined by "Data quantity", and a maximum of 16 pieces of data can be written.

For example, to write 5000 (1388H) and 50 (0032H) respectively to 0004H and 0005H of the VFD whose slave address is 02H, the frame structure is as follows.

RTU master command (from the master to the VFD)

START	T1-T2-T3-T4 (time gap with a min. length of 3.5 bytes)
ADDR	02H
CMD	10H
MSB of data writing address	00H
LSB of data writing address	04H
Data count MSB	00H
Data count LSB	02H
Number of bytes	04H
MSB of data to be written to 0004H	13H
LSB of data to be written to 0004H	88H
MSB of data to be written to 0005H	00H
LSB of data to be written to 0005H	32H
CRC LSB	C5H
CRC MSB	6EH
End	T1-T2-T3-T4 (time gap with a min. length of 3.5 bytes)

RTU slave response (from the VFD to the master)

START	T1-T2-T3-T4 (time gap with a min. length of 3.5 bytes)
ADDR	02H
CMD	10H
MSB of data writing address	00H
LSB of data writing address	04H
Data count MSB	00H
Data count LSB	02H
CRC LSB	C5H
CRC MSB	6EH
End	T1-T2-T3-T4 (time gap with a min. length of 3.5 bytes)

9.4.4 Data address definition

This section describes the address definition of communication data. The addresses are used for controlling the running, obtaining the state information, and setting related function parameters of the VFD.

9.4.4.1 Function code address format rules

The address of a function code consists of two bytes, with the MSB on the left and LSB on the right. The MSB ranges from 00 to ffH, and the LSB also ranges from 00 to ffH. The MSB is the hexadecimal form of the group number before the dot mark, and LSB is that of the number behind the dot mark. Take P05.06 as an example: The group number is 05, that is, the MSB of the parameter address is the hexadecimal form of 05; and the number behind the dot mark is 06, that is, the LSB is the hexadecimal form of 05. Therefore, the function code address is 0506H in the hexadecimal form. For example, the parameter address of P10.01 is 0A01H.

Function code	Name	Description	Setting range	Default	Modify
P10.00	Simple PLC mode	0: Stop after running once 1: Keep running with the final value after running once 2: Cyclic running	0–2	0	<input type="radio"/>
P10.01	Simple PLC memory selection	0: Do not memorize at power outage 1: Memorize at power outage	0–1	0	<input type="radio"/>

Note:

- ❖ The parameters in the P99 group are set by the manufacturer and cannot be read or modified. Some parameters cannot be modified when the VFD is running; some cannot be modified regardless of the VFD status. Pay attention to the setting range, unit, and description of a parameter when modifying it.
- ❖ The service life of the Electrically Erasable Programmable Read-Only Memory (EEPROM) may be reduced if it is frequently used for storage. Some function codes do not need to be stored during communication. The application requirements can be met by modifying the value of the on-chip RAM, that is, modifying the MSB of the corresponding function code address from 0 to 1. For example, if P00.07 is not to be stored in the EEPROM, you need only to modify the value of the RAM, that is, set the address to 8007H. The address can be used only for writing data to the on-chip RAM, and it is invalid when used for reading data.

9.4.4.2 Addresses of other Modbus functions

In addition to modifying the parameters of the VFD, the master can also control the VFD, such as starting and stopping it, and monitoring the operation status of the VFD.

Table 9-1 Addresses of other function parameters

Function description	Address definition	Data description	R/W
Communication-based control command	2000H	0001H: Run forward	R/W
		0002H: Run reversely	
		0003H: Jog forward	

Function description	Address definition	Data description	R/W
		0004H: Jog reversely	
		0005H: Stop	
		0006H: Coast to stop	
		0007H: Fault reset	
		0008H: Jogging stop	
Communication-based setting address	2001H	Communication-based frequency setting (0–Fmax, unit: 0.01Hz)	R/W
	2002H	PID reference (0–1000, in which 1000 corresponds to 100.0%)	R/W
	2003H	PID feedback (0–1000, in which 1000 corresponds to 100.0%)	R/W
	2004H	Torque setting (-3000–3000, in which 1000 corresponds to 100.0% of the motor rated current)	R/W
	2005H	Upper limit setting of forward running frequency (0–Fmax; unit: 0.01Hz)	R/W
	2006H	Upper limit setting of reverse running frequency (0–Fmax; unit: 0.01Hz)	R/W
	2007H	Upper limit of the electromotive torque (0–3000, in which 1000 corresponds to 100.0% of the motor rated current)	R/W
	2008H	Upper limit of the braking torque (0–3000, in which 1000 corresponds to 100.0% of the motor rated current)	R/W
	2009H	Special control command word Bit1–bit0=00: Motor 1 =01: Motor 2 Bit2=1: Enable speed/torque control switchover =0: Disable speed/torque control switchover Bit3=1: Clear electricity consumption data =0: Keep electricity consumption data Bit4=1: Enable pre-excitation =0: Disable pre-excitation Bit5=1: Enable DC braking =0: Disable DC braking	R/W
	200AH	Virtual input terminal command (0x000–0x3FF) Corresponding to S8/ S7/ S6/ S5/Reserved/HDIA/S4/S3/S2/S1 in sequence.	R/W
200BH	Virtual output terminal command, range: 0x00–0x0F	R/W	

Function description	Address definition	Data description	R/W
		The bits correspond to the local terminals: RO2/RO1/Reserved/Y1 in sequence.	
	200CH	Voltage setting (used when V/F separation is implemented) (0–1000, in which 1000 corresponds to 100.0% of the motor rated voltage)	R/W
	200DH	AO setting 1 (-1000+1000, in which 1000 corresponding to 100.0%)	R/W
	200EH	AO setting 2 (-1000+1000, in which 1000 corresponding to 100.0%)	R/W
VFD status word 1	2100H	0001H: Forward running	R
		0002H: Reverse running	
		0003H: Stopped	
		0004H: VFD in fault	
		0005H: POFF	
		0006H: Pre-exciting	
VFD status word 2	2101H	Bit0=0: Not ready to run =1: Ready to run Bit2–bit1=00: Motor 1 =01: Motor 2 Bit3=0: Asynchronous motor =1: Synchronous motor Bit4=0: No overload pre-alarm =1: Overload pre-alarm bit5–Bit6=0: Keypad-based control =1: Terminal-based control =2: Communication-based control Bit 7: Reserved Bit8=0: Speed control =1: Torque control Bit9=0: Non position control =1: Position control Bit11–Bit10: =00: Vector 0 =01: Vector 1 =10: Closed-loop vector =11: Space voltage vector	R
VFD fault code	2102H	See the description of fault types.	R
VFD identification code	2103H	GD270----0x01c0	R
Running frequency	3000H	0–Fmax (Unit: 0.01Hz)	Compatible with CHF100A and CHV100 communication
Set frequency	3001H	0–Fmax (Unit: 0.01Hz)	
Bus voltage	3002H	0.0–2000.0V (Unit: 0.1V)	
Output voltage	3003H	0–1200V (Unit: 1V)	

Function description	Address definition	Data description	R/W
Output current	3004H	0.0–3000.0A (Unit: 0.1A)	addresses
Rotational speed	3005H	0–65535 (Unit: 1RPM)	
Output power	3006H	-300.0%–300.0% (Unit: 0.1%)	
Output torque	3007H	-250.0–250.0% (Unit: 0.1%)	
Closed-loop setting	3008H	-100.0–100.0% (Unit: 0.1%)	
Closed-loop feedback	3009H	-100.0–100.0% (Unit: 0.1%)	
Input I/O status	300AH	00–3F Corresponding to the local Reserved/HDIA/S4/S3/S2/S1	
Output I/O status	300BH	00–0F The bits correspond to the local terminals: RO2/RO1/Reserved/Y1 in sequence.	R
Analog input 1	300CH	0.00–10.00V (Unit: 0.01V)	R
Analog input 2	300DH	0.00–10.00V (Unit: 0.01V)	R
Analog input 3	300EH	-10.00–10.00V (Unit: 0.01V)	R
Analog input 4	300FH	/	R
Read input of HDIA high-speed pulse	3010H	0.00–50.00kHz (Unit: 0.01Hz)	R
Reserved	3011H	/	R
Read the actual step of multi-step speed	3012H	0–15	R
External length value	3013H	0–65535	R
External counting value	3014H	0–65535	R
Torque setting	3015H	-300.0%–300.0% (Unit: 0.1%)	R
VFD identification code	3016H	/	R
Fault code	5000H	/	R

The Read/Write (R/W) characteristics indicate whether a function parameter can be read and written. For example, "Communication-based control command" can be written, and therefore the command code 06H is used to control the VFD. The R characteristic indicates that a function parameter can only be read, and W indicates that a function parameter can only be written.

Note: Some parameters in the preceding table are valid only after they are enabled. Take the running and stop operations as examples, you need to set "Running command channel" (P00.01) to "Communication", and set "Communication mode of running commands" (P00.02) to Modbus. For another example, when modifying "PID reference", you need to set "PID reference source" (P09.00) to Modbus communication.

The following table describes the encoding rules of device codes (corresponding to the identification code 2103H of the VFD).

8 MSBs	Meaning	8 LSBs	Meaning
0x01	Goodrive	0xc0	GD270 vector VFD

9.4.5 Fieldbus scale

In practical applications, communication data is represented in the hexadecimal form, but hexadecimal values cannot represent decimals. For example, 50.12 Hz cannot be represented in the hexadecimal form. In such cases, multiply 50.12 by 100 to obtain an integer 5012, and then 50.12 can be represented as 1394H in the hexadecimal form (5012 in the decimal form).

In the process of multiplying a non-integer by a multiple to obtain an integer, the multiple is referred to as a fieldbus scale.

The fieldbus scale depends on the number of decimal places in the value specified in "Setting range" or "Default". If there are n (for example, 1) decimal places in the value, the fieldbus scale m (then $m=10$) is the result of 10 to the power of n . Take the following table as an example.

Function code	Name	Description	Setting range	Default	Modify
P01.20	Wake-up-from-sleep delay	0.0–3600.0s (valid only when P01.19=2)	0.0–3600.0	0.0s	<input type="radio"/>
P01.21	Power-off restart selection	0: Disable 1: Enable	0–1	0	<input type="radio"/>

If "Setting range" or "Default value" contains one decimal, the fieldbus scale is 10. If the value received by the host controller is 50, "Delay of auto fault reset" of the rectifier is 5.0 (5.0=50/10).

To set "Wake-up-from-sleep delay" to 5.0s through Modbus communication, you need first to multiply 5.0 by 10 according to the scale to obtain an integer 50, that is, 32H in the hexadecimal form,

01 06 01 14 00 32 49 E7
 VFD Write Parameter Parameter CRC
 address command address data

After receiving the command, the VFD converts 50 into 5.0 based on the fieldbus scale, and then sets "Wake-up-from-sleep delay" to 5.0s.

For another example, after the host controller sends the "Wake-up-from-sleep delay" parameter read command, the master receives the following response from the VFD:

01 03 02 00 32 39 91
 VFD Read 2-byte Parameter CRC
 address command data data

The parameter data is 0032H, that is, 50, and therefore 5.0 is obtained based on the fieldbus scale (50/10=5.0). In this case, the master identifies that "Wake-up-from-sleep delay" is 5.0s.

9.4.6 Error message response

Operation errors may occur in communication-based control. For example, some parameters can only be read, but a write command is sent. In this case, the VFD returns an error message response.

Error message responses are sent from the VFD to the master. The following table lists the codes and definitions of the error message responses.

Code	Name	Meaning
01H	Invalid command	The command code received by the host controller is not allowed to be executed. The possible causes are as follows: <ul style="list-style-type: none"> • The function code is applicable only on new devices and is not implemented on this device. • The slave is in faulty state when processing this request.
02H	Invalid data address	For the VFD, the data address in the request of the host controller is not allowed. In particular, the combination of the register address and the number of the to-be-sent bytes is invalid.
03H	Invalid data value	The received data domain contains a value that is not allowed. The value indicates the error of the remaining structure in the combined request. Note: It does not mean that the data item submitted for storage in the register includes a value unexpected by the program.
04H	Operation failure	The parameter setting is invalid in the write operation. For example, a function input terminal cannot be set repeatedly.
05H	Incorrect password	The password entered in the password verification address is different from that is specified by P07.00.
06H	Incorrect data frame	The data frame sent from the host controller is incorrect in the length, or in the RTU format, the value of the CRC check bit is inconsistent with the CRC value calculated by the downstream device.
07H	Parameter read-only	The parameter to be modified in the write operation of the host controller is a read-only parameter.
08H	Parameter cannot be modified in running	The parameter to be modified in the write operation of the host controller cannot be modified during the running of the VFD.
09H	Password protection	If the host controller does not provide the correct password to unlock the system to perform a read or write operation, the error of "system being locked" is reported.

When returning a response, the slave uses a function code domain and fault address to indicate whether it is a normal response (no error) or exception response (an error occurs). In a normal response, the slave returns the corresponding function code and data address or sub-function code.

In an exception response, the slave returns a code that is equal to a normal code, but the first bit is logic 1.

For example, if the master sends a request message to a slave for reading a group of function code address data, the following code is generated:

0 0 0 0 0 0 1 1 (03H in the hexadecimal form)

In a normal response, the slave returns the same function code. In an exception response, the slave returns the following code:

1 0 0 0 0 0 1 1 (83H in the hexadecimal form)

In addition to the modification of the code, the slave returns a byte of exception code that describes the cause of the exception. After receiving the exception response, the typical processing of the master is to send the request message again or modify the command based on the fault information.

For example, to set the "Channel of running commands" (P00.01, the parameter address is 0001H) to 03 for the VFD whose address is 01H, the command is as follows:

<u>01</u>	<u>06</u>	<u>00 01</u>	<u>00 03</u>	<u>98 0B</u>
VFD address	Write command	Parameter address	Parameter data	CRC

However, the "Running command channel" ranges from 0 to 2. The value 3 is out of the setting range. In this case, the VFD returns an error message response.

<u>01</u>	<u>86</u>	<u>04</u>	<u>43 A3</u>
VFD address	Exception response code	Error code	CRC

The exception response code 86H (generated based on the MSB "1" of the write command 06H) indicates that it is an exception response to the write command (06H). The error code is 04H that indicates the error "Operation failure", which means "The parameter is set to an invalid value in the write operation".

9.4.7 Reading and writing examples

For the formats of the read and write commands, see sections 9.4.1 and 9.4.2.

9.4.7.1 Example of reading command 03H

Example 1: Read state word 1 of the VFD whose address is 01H. According to the table of other Modbus function addresses in Table 9-1, the parameter address of status word 1 of the VFD is 2100H,

The read command transmitted to the VFD is as follows:

<u>01</u>	<u>03</u>	<u>21 00</u>	<u>00 01</u>	<u>8E 36</u>
VFD address	Read command	Parameter address	Data quantity	CRC

Assume that the following response is returned:

<u>01</u>	<u>03</u>	<u>02</u>	<u>00 03</u>	<u>F8 45</u>
VFD address	Read command	Number of bytes	Data content	CRC

The data content returned by the VFD is 0003H, which indicates that the VFD is in the stopped state.

Example 2: View information about the VFD whose address is 03H, including "Present fault type" (P07.27) to "5th-last fault type" (P07.32) of which the parameter addresses are 071BH to 0720H (contiguous 6 parameter addresses starting from 071BH).

The command transmitted to the VFD is as follows:

<u>03</u>	<u>03</u>	<u>07 1B</u>	<u>00 06</u>	<u>B5 59</u>
VFD address	Read command	Start address	6 parameters in total	CRC

Assume that the following response is returned:

<u>03</u>	<u>03</u>	<u>0C</u>	<u>00 23</u>	<u>00 23</u>	<u>00 23</u>	<u>00 23</u>	<u>00 23</u>	<u>00 23</u>	<u>00 23</u>	<u>5F D2</u>
VFD address	Read command	Number of bytes	Most recent fault type	Last fault type	2nd-last fault type	3rd-last fault type	4th-last fault type	5th-last fault type		CRC

From the returned data, we can see that all the fault types are 0023H, that is, 35 in the decimal form, which means the maladjustment fault (STo).

9.4.7.2 Write command 06H examples

Example 1: Set the VFD whose address is 03H to be forward running. According to Table 9-1 other function parameters, the address of "Communication-based control command" is 2000H, and 0001H indicates forward running.

Function description	Address definition	Data description	R/W
Communication-based control command	2000H	0001H: Run forward	R/W
		0002H: Run reversely	
		0003H: Jog forward	
		0004H: Jog reversely	
		0005H: Stop	
		0006H: Coast to stop	
		0007H: Fault reset	
		0008H: Jogging stop	

The command transmitted from the master is as follows:

03 **06** **20 00** **00 01** **42 28**
 VFD Write Parameter Forward CRC
 address command address running

If the operation is successful, the following response (same as the command transmitted from the master) is returned:

03 **06** **20 00** **00 01** **42 28**
 VFD Write Parameter Forward CRC
 address command address running

Example 2: Set the max. output frequency to 100 Hz for the VFD with the address of 03H.

Function code	Name	Description	Setting range	Default	Modify
P00.03	Max. output frequency	P00.04–400Hz	100.00–400.00	50.00Hz	⊙

According to the number of decimal places, the fieldbus scale of max. output frequency (P00.03) is 100. 100Hz timed by 100 is 10000 and the corresponding hex is 2710H.

The command transmitted from the master is as follows:

03 **06** **00 03** **27 10** **62 14**
 VFD Write Parameter Parameter CRC
 address command address data

If the operation is successful, the following response (same as the command transmitted from the master) is returned:

03 **06** **00 03** **27 10** **62 14**
 VFD Write Parameter Parameter CRC
 address command address data

Note: In the preceding command description, spaces are added to a command just for explanatory purposes. In practical applications, no space is required in the commands.

9.4.7.3 Example of continuously writing command 10H

Example 1: Set the VFD whose address is 01H to be forward running at the frequency of 10Hz. According to Table 9-1 other Modbus function addresses, the address of "Communication-based control command" is 2000H, and 0001H indicates forward running. and the address of "Communication-based value setting" is 2001H, as shown in the following figure. 10 Hz is 03E8H in the hexadecimal form.

Function description	Address definition	Data description	R/W
Communication-based	2000H	0001H: Run forward	R/W

Function description	Address definition	Data description	R/W
control command		0002H: Run reversely	
		0003H: Jog forward	
		0004H: Jog reversely	
		0005H: Stop	
		0006H: Coast to stop	
		0007H: Fault reset	
		0008H: Jogging stop	
Communication-based setting address	2001H	Communication-based frequency setting (0–Fmax, unit: 0.01Hz)	R/W
	2002H	PID reference (0–1000, in which 1000 corresponds to 100.0%)	

In the actual operation, set P00.01 to 2 and P00.06 to 8.

The command sent from the master is as follows:

01 10 20 00 00 02 04 00 01 03 E8 3B 10
 VFD Continuous Parameter Parameter Number of Forward 10 Hz CRC
 address write address quantity bytes running

If the operation is successful, the following response is returned:

01 10 20 00 00 02 4A 08
 VFD Continuous Parameter Parameter CRC
 address write address quantity

Example 2: Set "Acceleration time" of the VFD whose address is 01H to 10s, and "Deceleration time" to 20s.

Function code	Name	Description	Default	Modify
P00.11	ACC time 1	P00.11 and P00.12 setting range:	Model depended	<input type="radio"/>
P00.12	DEC time 1	0.0–3600.0s	Model depended	<input type="radio"/>

The address of P00.11 is 000B, 10s is 0064H in the hexadecimal form, and 20s is 00C8H in the hexadecimal form.

The command sent from the master is as follows:

01 10 00 0B 00 02 04 00 64 00 C8 F2 55
 VFD Continuous Parameter Parameter Number of 10s 20s CRC
 address write address quantity bytes

If the operation is successful, the following response is returned:

<u>01</u>	<u>10</u>	<u>00 0B</u>	<u>00 02</u>	<u>30 0A</u>
VFD address	Continuous write command	Parameter address	Parameter quantity	CRC

Note: In the preceding command description, spaces are added to a command just for explanatory purposes. In practical applications, no space is required in the commands.

9.4.7.4 Example of Modbus communication commissioning

A PC is used as the host, an RS232-RS485 converter is used for signal conversion, and the PC serial port used by the converter is COM1 (an RS232 port). The host controller commissioning software is the serial port commissioning assistant Commix, which can be downloaded from the Internet. Download a version that can automatically execute the CRC check function. The following figure shows the interface of Commix.

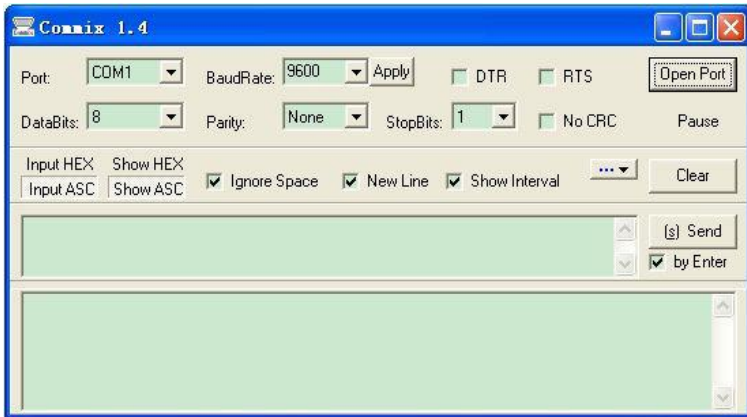

First, set the serial port to **COM1**. Then, set the baud rate consistently with P14.01. The data bits, check bits, and stop bits must be set consistently with P14.02. If the RTU mode is selected, you need to select the hexadecimal form **Input HEX**. To set the software to automatically execute the CRC function, you need to select **ModbusRTU**, select **CRC16 (Modbus RTU)**, and set the start byte to 1. After the auto CRC check function is enabled, do not enter CRC information in commands. Otherwise, command errors may occur due to repeated CRC check.

The commissioning command to set the VFD whose address is 03H to run forward is as follows:

<u>03</u>	<u>06</u>	<u>20 00</u>	<u>00 01</u>	<u>42 28</u>
VFD address	Write command	Parameter address	Forward running	CRC

Note:

1. Set the address (P14.00) of the VFD to 03.

2. Set "Channel of running commands" (P00.01) to "Communication", and set "Communication channel of running commands" (P00.02) to the Modbus communication channel.
3. After you click **Send**, if the line configuration and settings are correct, a response transmitted by the VFD is received.

9.5 Common communication faults

Common communication faults include the following:

- No response is returned.
- The VFD returns an exception response.

Possible causes of no response include the following:

1. The serial port is set incorrectly. For example, the adapter uses the serial port COM1, but COM2 is selected for the communication.
2. The settings of the baud rates, data bits, end bits, and check bits are inconsistent with those set on the VFD.
3. The positive pole (+) and negative pole (-) of the RS485 bus are connected reversely.
4. The resistor connected to 485 terminals on the terminal block of the VFD is set incorrectly.

Appendix A Expansion card

A.1 Model definition

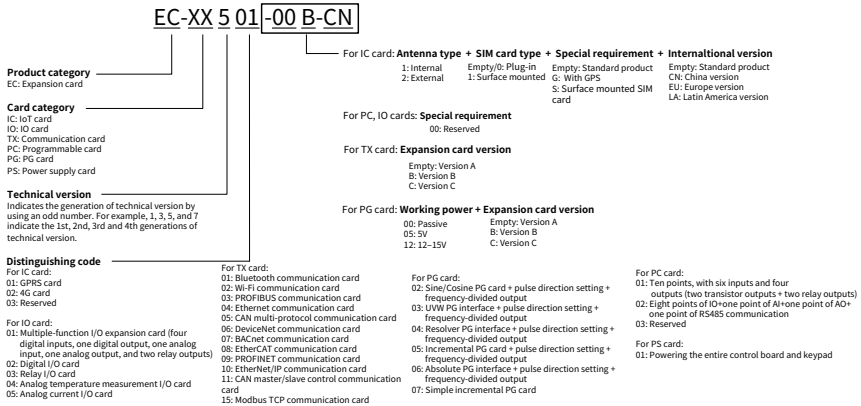

The following table describes expansion cards that the VFD supports. The expansion cards are optional and need to be purchased separately.

Name	Model	Specification	Ordering information
I/O expansion card	EC-IO501-00	<ul style="list-style-type: none"> Four digital inputs One digital output One analog input One analog output Two relay outputs: one double-contact output and one single-contact output 	11023-00083
	EC-IO503-00	<ul style="list-style-type: none"> Two digital inputs Six relay outputs 	11023-00136
PROFIBUS-DP communication card	EC-TX503D	<ul style="list-style-type: none"> Supporting the PROFIBUS-DP protocol 	11023-00151
CAN multi-protocol communication card	EC-TX505D	<ul style="list-style-type: none"> Based on the CAN2.0A physical layer Supporting the CANopen protocol Adopting INVT master-slave control proprietary protocol 	11023-00164
PROFINET communication card	EC-TX509C	<ul style="list-style-type: none"> Supporting the PROFINET protocol 	11023-00149
BACnet MSTP	EC-TX507B	<ul style="list-style-type: none"> Supporting the BACnet protocol and BACnet 	11023-00163

Name	Model	Specification	Ordering information
communication card		MSTP devices. <ul style="list-style-type: none"> ● Providing one BACnet MSTP port and supports half-duplex operations of 115.2kbps. ● Adopting the shielded twisted-pair cable and supporting the daisy chain connection network topologies, with the number of slave nodes up to 31. ● Supporting timeout detection. 	
EtherNet IP/ Modbus TCP protocol communication card	EC-TX510B	When the switch selects EtherNet IP: <ul style="list-style-type: none"> ● Supporting the EtherNet IP protocol and EtherNet IP ● Equipped with two EtherNet IP ports, supporting 10M/100M half/full duplex operating. ● Equipped with two RJ45 interfaces, which do not distinguish the direction and can be swappable ● Supporting star and line IP network topologies When the switch selects Modbus TCP: <ul style="list-style-type: none"> ● Supporting the Modbus TCP protocol and Modbus TCP secondary nodes ● Equipped with two Modbus TCP ports, supporting 10M/100M half/full duplex operating ● Supporting star and line TCP network topologies When the switch selects Ethernet: <ul style="list-style-type: none"> ● Supporting INVT Ethernet protocol ● Supporting the connection to INVT's host controller monitoring software INVT Workshop for monitoring and oscillography, allowing multi-card networking monitoring 	11023-00197
24V power supply expansion card	EC-PS501-24	<ul style="list-style-type: none"> ● Input voltage range: DC18–30V(Rated 24Vdc)/2A ● Three channels of output voltage: +5V/1A (±5%), +15V/0.2A (±10%), -15V/0.2A (±10%) 	11023-00135

A.2 Dimensions and installation

All expansion cards are of the same dimensions (108x 39mm) and can be installed in the same way.

All the VFD models provide two expansion card slots. Note the following when installing or uninstalling an expansion card:

1. Ensure that no power is applied before installing the expansion card.
2. To ease wiring, comply with the following although any supported expansion card at either slot can be identified:

Cabinet power range	Installation precautions
1.5–7.5kW	Install a communication card in SLOT2. Before installing a DP communication card, remove the middle casing and lower casing.
11–800kW	It is recommended to install a DP communication card in SLOT1.

The following figure shows the installation diagram and a VFD with expansion cards installed.

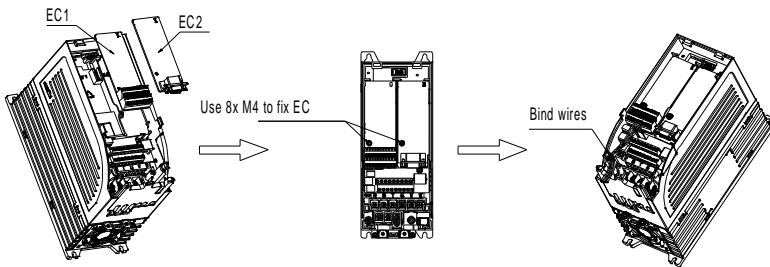

Figure A-1 1.5–7.5kW VFDs with expansion cards installed

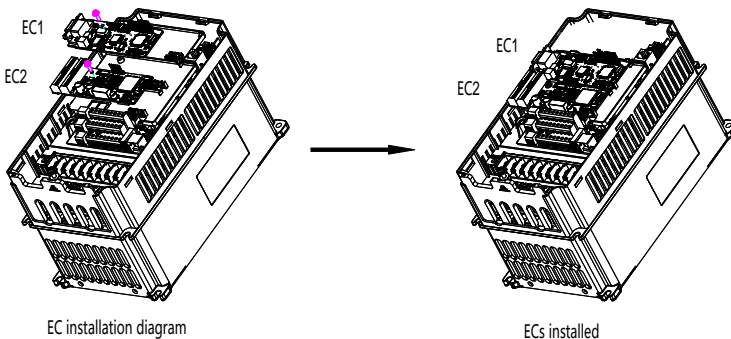

Figure A-2 11–800kW VFDs with expansion cards installed

Figure A-3 shows the expansion card installation procedure.

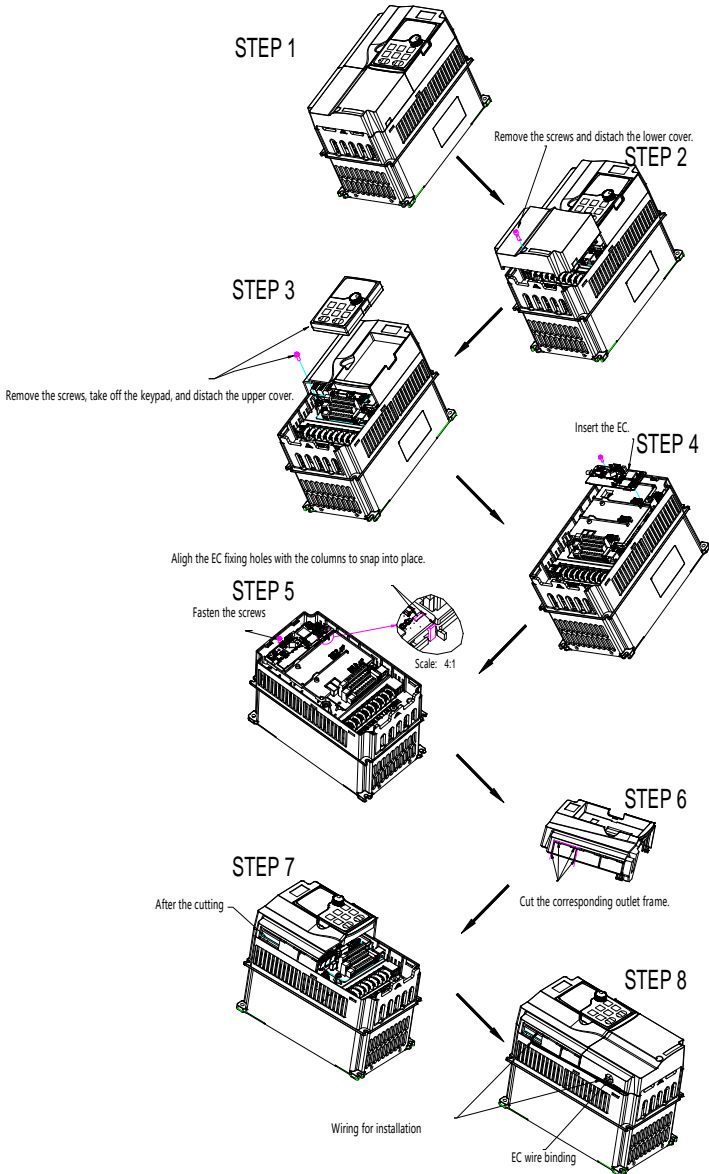

Figure A-3 Expansion card installation procedure

A.3 Wiring

1. Ground a shielded cable as follows.

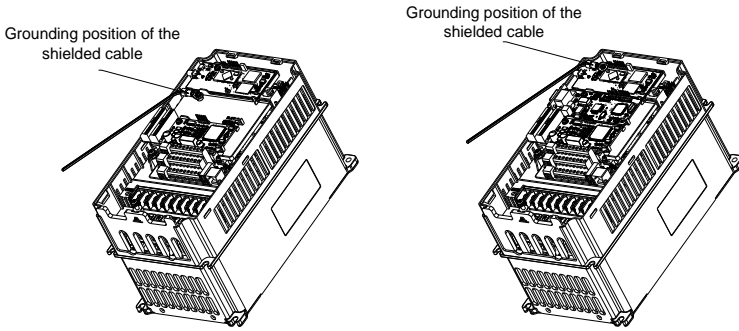

Figure A-4 Expansion card grounding

2. Wire an expansion card as follows:

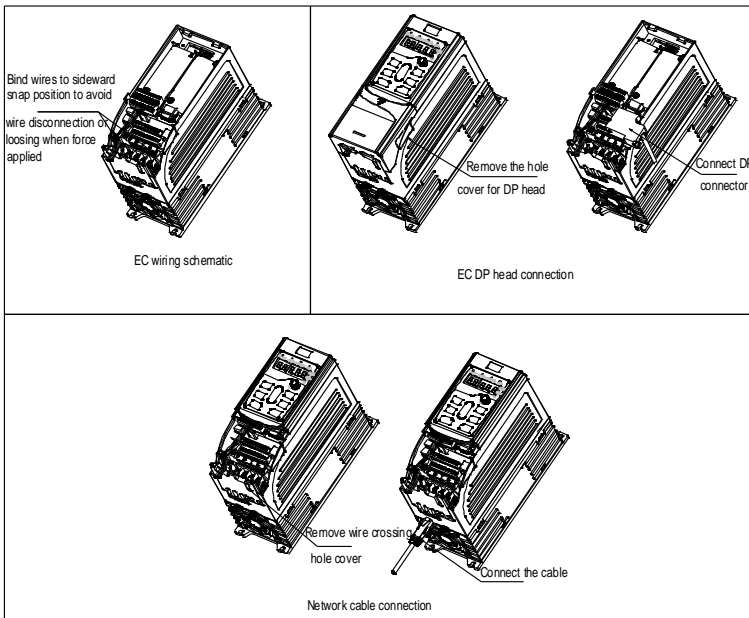

Figure A-5 Expansion card wiring for 1.5–7.5kW VFDs

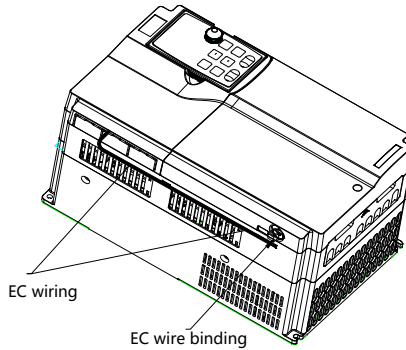
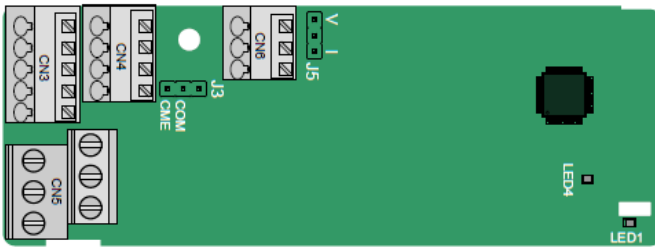

Figure A-6 Expansion card wiring for 11–630kW VFDs

A.4 I/O expansion cards

A.4.1 EC-IO501-00



The terminals are arranged as follows:

COM and CME are shorted through J3 before delivery, and J5 is the jumper for selecting the output type (voltage or current) of AO2.

AI3	AO2	GND
-----	-----	-----

COM	CME	Y2	S5	
PW	+24V	S6	S7	S8

RO3A	RO3B	RO3C
RO4A		RO4C

Indicator definition:

Indicator	Definition	Function
LED1	Status indicator	On: The expansion card is connecting with the control board. Blinking (On: 500ms; Off: 500ms): The expansion card is connected with the control board. Off: The expansion card is disconnected from the control board.

Indicator	Definition	Function
LED4	Power indicator	On: The expansion card is powered on. Off: The expansion card is not powered on.

EC-IO501-00 can be used in scenarios where the I/O interfaces of VFD cannot meet the application requirements. It can provide 4 digital inputs, 1 digital output, 1 analog input, 1 analog output, and two relay outputs. It is user-friendly, providing relay outputs through European-type screw terminals and other inputs and outputs through spring terminals.

EC-IO501-00 terminal functions:

Category	Terminal symbol	Terminal name	Description
Power supply	PW	External power	Used to provide input digital working power from the external to the internal Voltage range: 12–24V PW and +24V have been short connected before delivery.
Analog input and output	AI3—GND	Analog input 1	<ul style="list-style-type: none"> ● Input range: For AI3, 0(2)–10V or 0(4)–20mA ● Input impedance: 20kΩ for voltage input or 250Ω for current input ● Whether voltage or current is used for input is set through the corresponding function code. ● Resolution: 5mV when 10V corresponds to 50Hz ● Error: ±0.5% when input is above 5V or 10mA at 25°C
	AO2—GND	Analog output 1	<ul style="list-style-type: none"> ● Output range: 0(2)–10V or 0(4)–20mA ● Whether voltage or current is used for output is set through the jumper J5. ● Error: ±0.5% when output is above 5V or 10mA at 25°C
Digital input and output	S5—COM	Digital input 1	<ul style="list-style-type: none"> ● Internal impedance: 3.3kΩ ● 12–30V voltage input is acceptable ● Bi-direction input terminal ● Max. input frequency: 1kHz
	S6—COM	Digital input 2	
	S7—COM	Digital input 3	
	S8—COM	Digital input 4	
	Y2—CME	Digital output	<ul style="list-style-type: none"> ● Switch capacity: 200mA/30V ● Output frequency range: 0–1kHz ● The terminals CME and COM are shorted through J3 before delivery.

Category	Terminal symbol	Terminal name	Description
Relay output	RO3A	NO contact of relay 3	<ul style="list-style-type: none"> ● Contact capacity: 3A/AC250V, 1A/DC30V ● Cannot be used as high frequency digital output.
	RO3B	NC contact of relay 3	
	RO3C	Common contact of relay 3	
	RO4A	NO contact of relay 4	
	RO4C	Common contact of relay 4	

A.4.2 EC-IO503-00

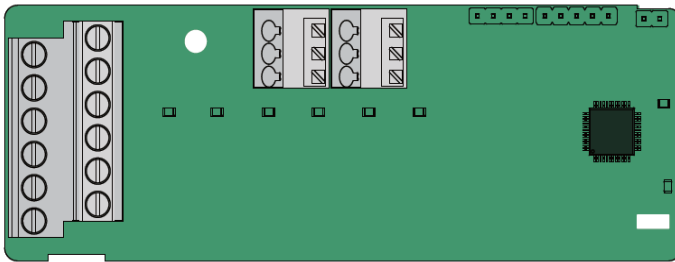

The terminals of EC-IO503-00 are arranged as follows:

COM	S9	S10
-----	----	-----

COM	PW	+24V
-----	----	------

RO5A	RO5C	RO6A	RO6C	RO7A	RO7C
RO8A	RO8C	RO9A	RO9C	RO10A	RO10C

Indicator definition:

Indicator	Definition	Function
LED1	Status indicator	On: RO5 is switched on. Off: RO5 is switched off.
LED2	Status indicator	On: RO6 is switched on. Off: RO6 is switched off.
LED3	Status indicator	On: RO7 is switched on. Off: RO7 is switched off.
LED4	Status indicator	On: RO8 is switched on. Off: RO8 is switched off.
LED5	Status indicator	On: RO9 is switched on. Off: RO9 is switched off.

Indicator	Definition	Function
LED6	Status indicator	On: RO10 is switched on. Off: RO10 is switched off.
LED7	Power indicator	On: The expansion card is powered on. Off: The expansion card is not powered on.
LED8	Status indicator	On: The expansion card is connecting with the control board. Blinking (On: 500ms; Off: 500ms): The expansion card is connected with the control board. Off: The expansion card is disconnected from the control board.

EC-IO503-00 can be used in scenarios where the I/O interfaces of VFD cannot meet the application requirements. It can provide 2 analog inputs and 6 analog outputs. It is user-friendly, providing relay outputs through European-type screw terminals and other inputs and outputs through spring terminals.

EC-IO503-00 terminal function description

Category	Terminal symbol	Terminal name	Description
Power supply	COM	External power	Used to provide I/O expansion card working power from the external to the internal Voltage: +24V PW and +24V are shorted during use
	PW		
	+24V		
Digital input	S9—COM	Digital input 1	<ul style="list-style-type: none"> ● Internal impedance: 3.3kΩ ● 12–30V voltage input is acceptable. ● Max. input frequency: 1kHz
	S10—COM	Digital input 2	
Relay output	RO5A	NO contact of relay 5	<ul style="list-style-type: none"> ● Contact capacity: 3A/AC250V, 1A/DC30V ● Cannot be used as high frequency digital output
	RO5C	NO contact of relay 5	
	RO6A	NO contact of relay 6	
	RO6C	NO contact of relay 6	
	RO7A	NO contact of relay 7	
	RO7C	NO contact of relay 7	
	RO8A	NO contact of relay 8	
	RO8C	NO contact of relay 8	
	RO9A	NO contact of relay 9	
	RO9C	NO contact of relay 9	
	RO10A	NO contact of relay 10	
	RO10C	NO contact of relay 10	

A.5 Communication cards

A.5.1 PROFIBUS-DP communication card (EC-TX503D)

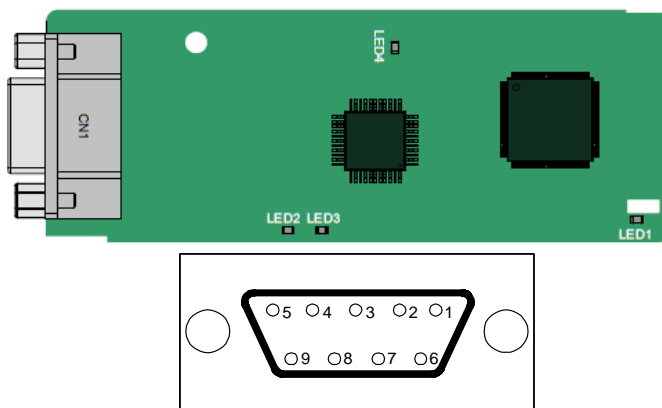

CN1 is a 9-pin D-type connector, as shown in the following figure.

Connector pin		Description
1	-	Unused
2	-	Unused
3	B-Line	Data+ (twisted pair 1)
4	RTS	Request sending
5	GND_BUS	Isolation ground
6	+5V BUS	Isolated power supply of 5 V DC
7	-	Unused
8	A-Line	Data- (twisted pair 2)
9	-	Unused
Housing	SHLD	PROFIBUS cable shielding line

+5V and GND_BUS are bus terminators. Some devices, such as the optical transceiver (RS485), may need to obtain power through these pins.

On some devices, the transmission and receiving directions are determined by RTS. In normal applications, only A-Line, B-Line, and the shield layer need to be used.

Indicator definition:

Indicator	Definition	Function
LED1	Status indicator	On: The expansion card is connecting with the control board. Blinking (On: 500ms; Off: 500ms): The expansion card is connected with the control board. Off: The expansion card is disconnected from the control board.
LED2	Online indicator	On: The communication card is online and data exchange can be

Indicator	Definition	Function
		performed. Off: The communication card is not in the online state.
LED3	Offline/Fault indicator	On: The communication card is offline and data exchange cannot be performed. Blinking: The communication card is not in the offline state. Blinking at the frequency of 1 Hz: A configuration error occurs. The length of the user parameter data set during the initialization of the communication card is different from that during the network configuration. Blinking at the frequency of 2 Hz: User parameter data is incorrect. The length or content of the user parameter data set during the initialization of the communication card is different from that during the network configuration. It blinks at the frequency of 4Hz when an error occurs in the ASIC initialization of PROFIBUS communication. Off: The diagnosis function is disabled.
LED4	Power indicator	On: The expansion card is powered on. Off: The expansion card is not powered on.

Note: For details, see the communication card manual.

A.5.2 CAN multi-protocol communication card (EC-TX505D)

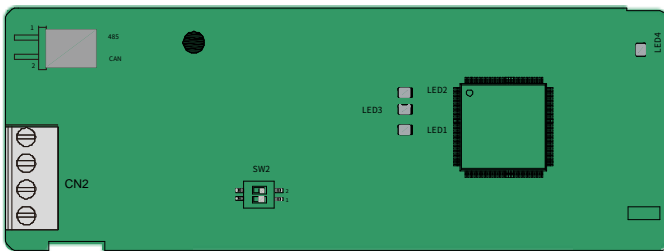

Table A-1 Parts on the EC-TX505D expansion card

Symbol	Name	Description
PGND	Isolation ground	Isolation ground
PE	Shielded cable	CAN bus shielding
CANH	CAN positive input	CAN bus high level signal
CANL	CAN negative input	CAN bus low level signal
485	RS485 terminal resistor switch	No terminal resistor is connected between RS485+ and RS485-.
		A 120 Ω terminal resistor is connected between RS485+ and RS485-.

Symbol	Name	Description
CAN	CAN terminal resistor switch	No terminal resistor is connected between CAN_H and CAN_L.
		A 120 Ω terminal resistor is connected between CAN_H and CAN_L.

Note: To select the protocol of this expansion card, please set the switch SW2 according to the following relationship before power on.

SW2		
1	2	Protocol type
OFF	OFF	CANopen
ON	OFF	CAN master/slave

Indicator	Definition	Function
LED1	Status indicator	On: The expansion card is connecting with the control board. Blinking (On: 500ms; Off: 500ms): The expansion card is connected with the control board. Off: The expansion card is disconnected from the control board.
LED2	Run indicator	On: The communication card is in the operating state. Blinking (On: 250 ms; Off: 250 ms): The communication card is in the pre-operation state. Off: A fault occurs; the reset pin of the communication card and the power supply are not properly connected; the expansion card is in a stopped state.
LED3	Fault indicator	On: The CAN controller bus is off; a fault occurs on the VFD; received frame lost or incorrect. Off: The communication card is in the working state.
LED4	Power indicator	On: The expansion card is powered on. Off: The expansion card is not powered on.

Note: For details, see the communication card manual.

A.5.3 PROFINET communication card (EC-TX509C)

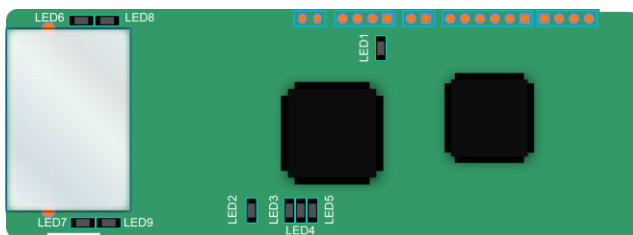

The terminal CN2 adopts standard RJ45 interfaces, which are in the dual design, and the two RJ45 interfaces are not distinguished from each other and can be interchangeably inserted. They are arranged as follows:

Pin	Name	Description
1	TX+	Transmit Data+
2	TX-	Transmit Data-
3	RX+	Receive Data+
4	n/c	Not connected
5	n/c	Not connected
6	RX-	Receive Data-
7	n/c	Not connected
8	n/c	Not connected

Indicator definition:

The PROFINET communication card has 9 indicators, among which LED1 is the power indicator, LED2–5 are the communication status indicators of the communication card, and LED6–9 are the status indicators of the network port.

Indicator	Color	Status	Description
LED1	Green	/	3.3V power indicator
LED2 (Bus status indicator)	Red	On	No network connection
		Blinking	The connection to the network cable between the PROFINET controller is OK, but the communication is not established.
		Off	Communication with the PROFINET controller has been established.
LED3 (System fault indicator)	Green	On	PROFINET diagnosis exists.
		Off	No PROFINET diagnosis.
LED4 (Slave ready indicator)	Green	On	TPS-1 protocol stack has started.
		Blinking	TPS-1 waits for MCU initialization.
		Off	TPS-1 protocol stack does not start.

Indicator	Color	Status	Description
LED5 (Maintenance status indicator)	Green	/	Manufacturer-specific, depending on the characteristics of the device.
LED6/7 (Network port status indicator)	Green	On	The PROFINET communication card and PC/PLC have been connected by using a network cable.
		Off	The connection between the PROFINET communication card and PC/PLC has not been established.
LED8/9 (Network port communication indicator)	Green	On	The PROFINET communication card and PC/PLC are communicating.
		Off	The PROFINET communication card and PC/PLC have no communication yet.

Electrical connection:

The PROFINET communication card adopts standard RJ45 interfaces, which can be used in a linear network topology and a star network topology. The linear network topology electrical connection diagram is shown in Figure A-7.

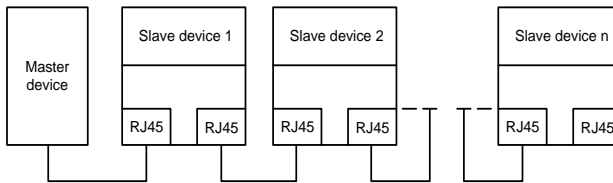

Figure A-7 Linear network topology electrical connection

Note: For the star network topology, you need to prepare PROFINET switches.

The star network topology electrical connection diagram is shown in Figure A-8.

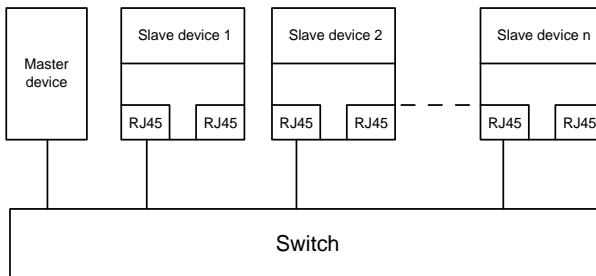
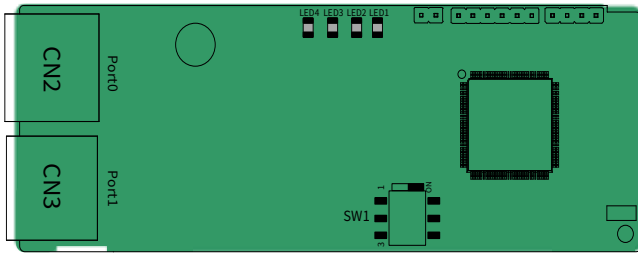

Figure A-8 Star network topology electrical connection

A.5.4 EtherNet IP and Modbus TCP protocol communication card (EC-TX510B)



The expansion card has two communication ports, both of which adopt standard RJ45 interfaces and can be interchangeably inserted. It supports selecting the protocol via the DIP switch before power-on. The default selection is EtherNet IP, with Modbus TCP and INVT's own Ethernet UDP protocol as optional choices.

Note: For this card, before power-on, set the SW2 switch according to the mapping between protocols and positions.

Table A-2 Switch definition

SW1	Protocol type	1	2	3
	EtherNet IP	ON	ON	ON
	EtherNet UDP	OFF	ON	ON
	Modbus TCP	ON	OFF	ON
	Reserved	Other	Other	Other

Table A-3 EtherNet IP indicator description

Indicator	Color	Definition	Function
LED1	Green	On	The expansion card is shaking hands with the VFD.
		Blinking (1Hz)	The expansion card and VFD communicate normally.
		Off	The expansion card and VFD communicate improperly.
LED2	Green	On	The communication between the expansion card and the PLC is online and data exchange is allowed.
		Off	The communication between the expansion card and PLC is offline.
LED3	Red	On	Failed to set up I/O between the expansion card and the PLC.
		Blinking (1Hz)	Incorrect PLC configuration.
		Blinking (2Hz)	The expansion card failed to send data to the PLC.
		Blinking (4Hz)	The connection between the expansion card and PLC timed out.
		Off	No fault
LED4	Red	On	3.3V power indicator

Table A-4 Modbus TCP indicator description

Indicator	Color	Definition	Function
LED1	Green	On	The expansion card is shaking hands with the VFD.
		Blinking (1Hz)	The expansion card and VFD communicate normally.
		Off	The expansion card and VFD communicate improperly.
LED2	Green	On	The communication between the expansion card and the PLC is online and data exchange is allowed.
		Off	The communication between the expansion card and PLC is offline.
LED3	Red	On	Expansion card has no valid data received.
		Blinking (1Hz)	The message function code is not used or defined
		Blinking (8Hz)	Message address error
		Off	No fault
LED4	Red	On	3.3V power indicator

Table A-5 Ethernet indicator description

Indicator	Color	Definition	Function
LED1	Green	On	The expansion card is shaking hands with the VFD.
		Blinking (1Hz)	The expansion card and VFD communicate normally (handshake successful).
		Off	The expansion card and VFD communicate improperly.
LED2	Green	On	The connection between the expansion card and PC is successful.
		Off	The expansion card fails to connect with PC (abnormal network cable).
LED3	Red	Blinking (4Hz)	The expansion card is successfully connected to the PC but communication fails (abnormal IP address).
		Off	No fault
LED4	Red	On	3.3V power indicator

Electrical connection:

The communication card adopts standard RJ45 interfaces, which can be used in a linear, star, and ring network topologies. The electrical connection diagram is shown as follows.

Use CAT5, CAT5e, and CAT6 network cables for electrical wiring. When the communication distance is greater than 50m, use high-quality network cables that meet the high-quality standards.

Table A-6 Terminal function definition

Signal	Port	Description
485+	RS485	Positive differential signal
485-		Negative differential signal
PGND	/	Signal ground
PE	/	Earth
485	Switch	OFF: Do not connect the terminal resistor ON: Connect the terminal resistor

Table A-7 Function description

Function description		Specifications
Main functions	Features	<ol style="list-style-type: none"> Supporting the BACnet protocol and BACnet MSTP devices. Providing one BACnet MSTP port and supports half-duplex operations of 115.2kbps. Adopting the shielded twisted-pair cable and supporting the daisy chain connection network topologies, with the number of slave nodes up to 31. Supporting timeout detection.
	Service	<ol style="list-style-type: none"> Single-property reading service Multi-property reading service Single-property writing service Multi-property writing service I-Am service I-Have service Device communication control service Device re-initialization service
	Function	<ol style="list-style-type: none"> Supporting the setting of 32 analog objects. Supporting the reading and writing of VFD process data and function codes, reading of VFD status words, and writing of VFD control words. Supporting the Yet Another BACnet Explorer (YABE) host controller and PLC controller

Table A-8 Indicator functions

Indicator	Definition	Function
CTRL	Status indicator	On: The expansion card is connecting with the control board. Blinking periodically (the period is 1s, on for 0.5s, and off for the other 0.5s): The expansion card is properly connected to the control board. Off: The expansion card is disconnected from the control board.
RUN	Run indicator (green)	On: BACnet communication state. Received BACnet data frames. Blinking periodically (on-off at a 0.5s interval): Online. Waiting to receive BACnet data frames. Off: Not powered or in fault state

Indicator	Definition	Function
ERR	Fault indicator (red)	Off: No fault Blinking periodically (on-off at a 0.5s interval for twice and 2s off): Fault state. Duplicate address. The VFD keypad reports E-bac. Blinking periodically (on-off at a 0.5s interval for three times and 2s off): Fault state. No BACnet data frames received in specified time. (Timeout detection must be enabled, that is, the timeout time cannot be 0.) The VFD keypad reports an E-bac fault.
PWR	Power indicator	It is on once the control board feeds power to the BACnet MSTP card.
485_TXD	Transmission indicator (green)	On: Transmitting. The device is transmitting data fast on the RS485 network. Blinking: Transmitting. The device is transmitting data on the RS485 network. Off: Not transmitting. The device does not transmit data on the RS485 network.
485_RXD	Reception indicator (red)	On: Receiving. The device is receiving data fast on the RS485 network. Blinking: Receiving. The device is receiving data on the RS485 network. Off: Not receiving. The device does not receive data on the RS485 network.

A.5.6 24V power supply expansion card (EC-PS501-24)



Indicator definition:

Indicator	Definition	Function
LED1	24V power indicator	Indicator for the external 24V power.
LED2	5V power indicator	Indicator for the 5V power that is provided for the control board after the switch power converts external power.

The 24V power supply card is mainly used to connect to external 24V power to power the control board, avoiding to apply electricity for independent control board commissioning. During wiring, connect to +24V and COM according to the CN2 sign.

Appendix B Technical data

B.1 What this chapter contains

This chapter describes the technical data of the VFD and its compliance to CE and other quality certification systems.

B.2 Derated application

B.2.1 Capacity

Choose a VFD model based on the rated current and power of the motor. To ensure the rated power of the motor, the rated output current of the VFD must be larger or equal to the rated current of the motor. The rated power of the VFD must be higher or equal to that of the motor.

Note:

- ◇ The rated capacity is the capacity at the ambient temperature of 40°C.
- ◇ You need to check and ensure that the power flowing through the common DC connection in the common DC system does not exceed the rated power of the motor.

B.2.2 Derating

If the ambient temperature at the VFD installation site exceeds 40°C, the VFD installation site altitude exceeds 1000m, a cover with heat dissipation vents is used, or the carrier frequency is higher than the recommended (for the recommended frequency, see P00.14), the VFD needs to be derated.

B.2.2.1 Derating due to temperature

When the temperature ranges from 40°C to 50°C, the rated output current is derated by 1% for each increased 1°C. For the actual derating, see the following figure.

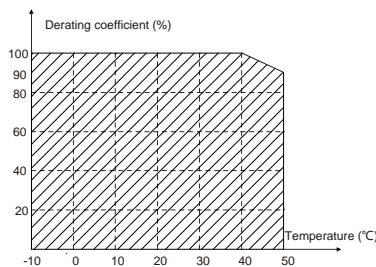

Note: It is not recommended to use the VFD at an environment with the temperature higher than 50°C. If you do, you shall be held accountable for the consequences caused.

B.2.2.2 Derating due to altitude

The VFD does not need to be derated when it is used below an altitude of 1000m. When it is used in the altitude range of 1000–4800m, the capacity is reduced by 1% for every increase of 100m.

Note: When the VFD is used at altitudes above 2000m and employs a corner grounding device, special considerations apply. For more information, please contact your local INVT representative.

B.2.2.3 Derating due to carrier frequency

The carrier frequency of the VFD varies with power class. The VFD rated power is defined based on the carrier frequency factory setting. If the carrier frequency exceeds the factory setting, the VFD power is derated by 10% for each increased 1 kHz.

B.3 Grid specifications

Grid voltage	AC 3PH 380V–480V
Short-circuit capacity	According to the definition in IEC 61439-1, the maximum allowable short-circuit current at the incoming end is 100 kA. Therefore, the VFD is applicable to scenarios where the transmitted current in the circuit is no larger than 100kA when the VFD runs at the maximum rated voltage.
Frequency	50/60Hz±5%, with a maximum change rate of 20%/s

B.4 Motor connection data

Motor type	Asynchronous induction motor or permanent-magnet synchronous motor
Voltage	0–U ₁ (motor rated voltage), 3PH symmetrical, U _{max} (VFD rated voltage) at the field-weakening point
Short-circuit protection	The motor output short-circuit protection meets the requirements of IEC 61800-5-1.
Frequency	0–400Hz
Frequency resolution	0.01Hz
Current	See section 3.6 "Product ratings".
Power limit	1.1 times of the motor rated power
Field-weakening point	10–400Hz
Carrier frequency	2, 4, 8, 12, or 15kHz

B.4.1 EMC compatibility and motor cable length

To meet IEC/EN61800-3 C3 and C2 electromagnetic environment requirements, GD270 series offers models with built-in filters. The allowable motor cable lengths (with shielding) under a 2kHz carrier frequency condition are shown in the following table.

Power range	Length of supported motor cable (with shield) (unit: m)	
	Environment category II (C3)	Environment category II (C2)
1.5–22kW (built-in C2 filter)	50	20
30–37kW (built-in C3 filter)	30	Not met
45–800kW (built-in C3 filter)	50	Not met

For details about the C3 and C2 EMC environment categories, see section B.6 EMC regulations.

Note: For 5.5–7.5kW models, an additional magnetic ring needs to be installed on the motor output

side for the VFD to achieve the motor cable length specifications listed in the table above. The magnetic ring is included as a standard accessory with the VFD.



B.5 Application standards

The following table describes the standards that VFDs comply with.

EN/ISO 13849-1	Safety of machinery—Safety-related parts of control systems—Part 1: General principles for design
IEC/EN 60204-1	Safety of machinery. Electrical equipment of machines. Part 1: General requirements
IEC/EN 62061	Safety of machinery—Safety-related functional safety of electrical, electronic, and programmable electronic control systems
IEC/EN 61800-3	Adjustable speed electrical power drive systems. Part 3: EMC requirements and specific test methods
IEC/EN 61800-5-1	Adjustable speed electrical power drive systems—Part 5-1: Safety requirements—Electrical, thermal and energy

B.5.1 CE marking

The CE marking on the VFD nameplate indicates that the VFD is CE-compliant, meeting the regulations of the European low-voltage directive (2014/35/EU) and EMC directive (2014/30/EU).

B.5.2 EMC compliance declaration

European union (EU) stipulates that the electric and electrical devices sold in Europe cannot generate electromagnetic disturbance that exceeds the limits stipulated in related standards, and can work properly in environments with certain electromagnetic interference. The EMC product standard (EN 61800-3) describes the EMC standards and specific test methods for adjustable speed electrical power drive systems. Our products have been compliant with these EMC regulations.

B.6 EMC regulations

The EMC product standard (EN 61800-3) describes the EMC requirements on VFDs.

Application environment categories:

First environment: Civilian environment, including application scenarios where VFDs are directly connected to the civil power supply low-voltage grids without intermediate transformers.

Second environment: All environments other than those directly connected to low-voltage power supply networks serving civilian applications.

VFD categories:

Category C1: VFD of rated voltage lower than 1000V, applied to the first environment.

Category C2: VFD of rated voltage lower than 1000V, which is neither a non-plug, socket, nor mobile devices and must be installed and commissioned by a professional person when used in the first environment.

Note: The EMC standard IEC/EN 61800-3 no longer restricts the power distribution of the VFD, but defines the use, installation, and commissioning of the VFD. Specialized personnel or organizations must have the necessary skills (including the EMC-related knowledge) for installing and/or performing commissioning on the electrical drive systems.

Category C3: VFD of rated voltage lower than 1000V, applied to the second environment. They cannot be applied to the first environment.

Category C4: VFD of rated voltage higher than 1000 V, or rated current higher or equal to 400 A, applied to complex systems in the second environment.

Appendix C Dimension drawings

C.1 What this chapter contains

This chapter provides the dimension drawings of the VFD, which use millimeter (mm) as the unit.

C.2 Keypad structure

C.2.1 Structure diagram

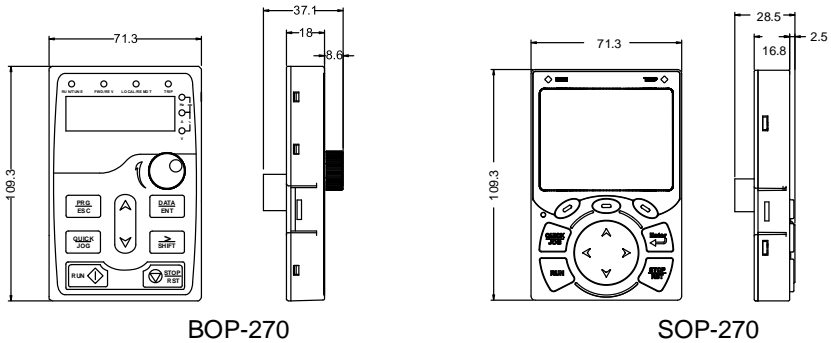

C.2.2 External installation of keypad

When users need to externally install the optional LED and LCD keypads of GD270 on the cabinet door, there are two installation methods are available.

Method 1: As shown in Figure C-1, cut a hole on the cabinet door according to the specified dimensions, purchase an external mounting bracket (model: GD350-JPZJ) for embedded installation, and then install the keypad into the bracket.

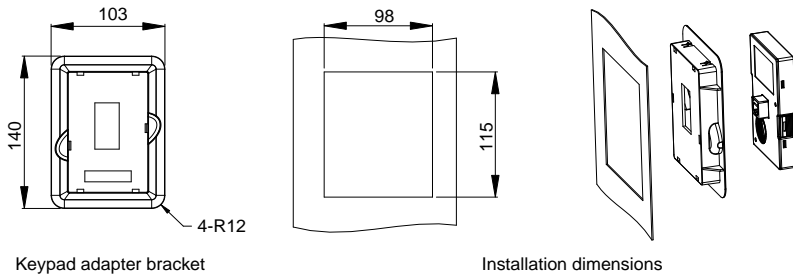
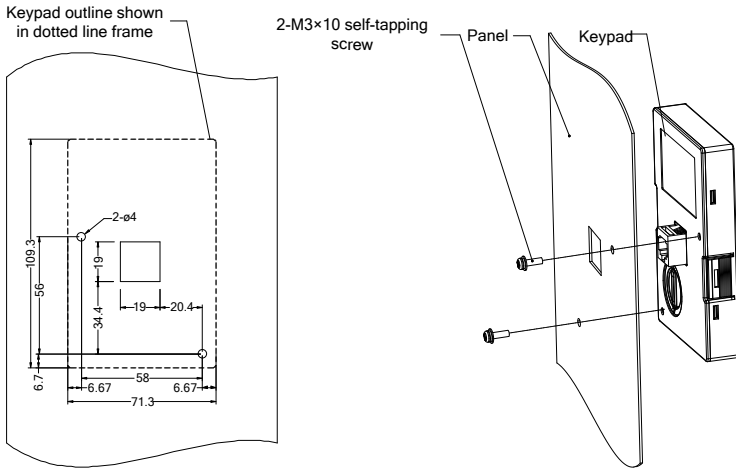

Figure C-1 (Optional) Keypad installation bracket

Method 2: According to Figure C-2, cut the fixing holes and keypad hole, and use the two M3 self-tapping screws provided to directly mounting.



Dimension and hole sizes for mounting keypad without a bracket

Figure C-2 Keypad hole dimensions without bracket

Note:

- ✧ When the local keypad of the 30–630kW models is externally installed, the keypad port on the VFD is prone to dust and foreign objects. It is recommended to purchase a keypad protective cover (model: GD270-JPFH) for sealing, as shown in Figure C-3.
- ✧ The network port outlet hole designed for the GD270 series protective cover will not be used. For details, see the external keypad wiring requirements in section 4.3.6 External optional keypad wiring.

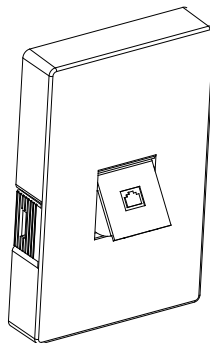

Figure C-3 Keypad protective cover

C.3 VFD structure

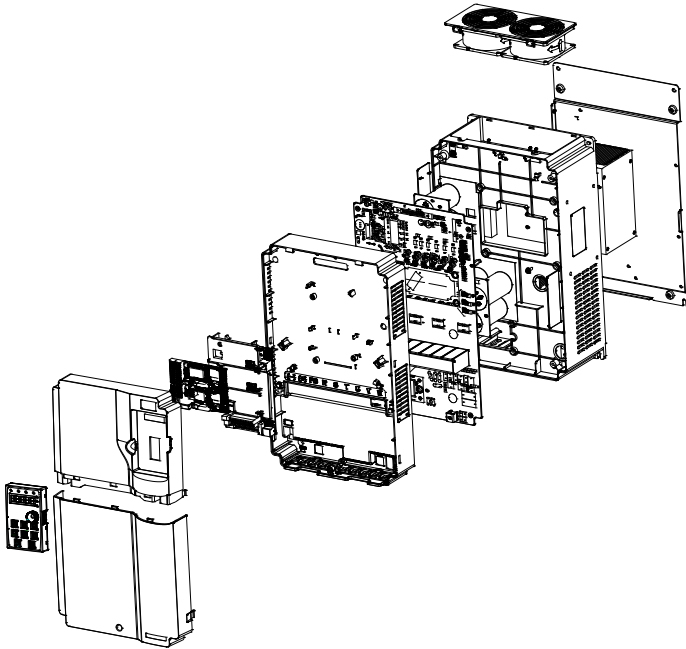

Figure C-4 VFD structure of 630kW and below models

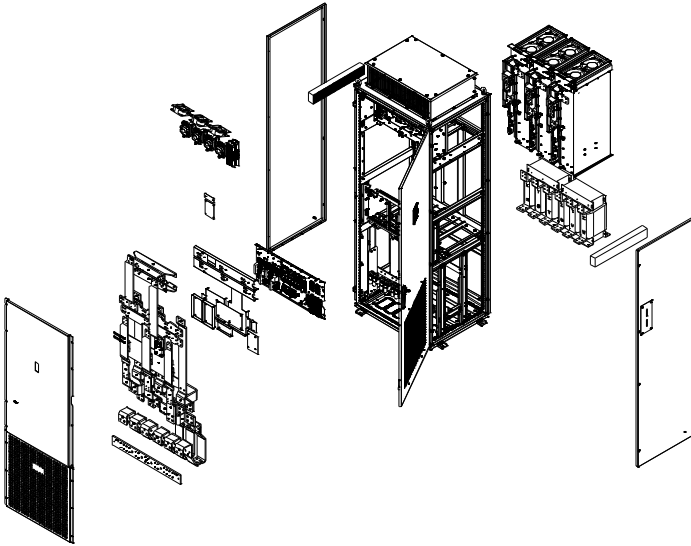

Figure C-5 VFD structure of 710–800kW models

C.4 Product dimensions

C.4.1 Wall-mounting dimensions

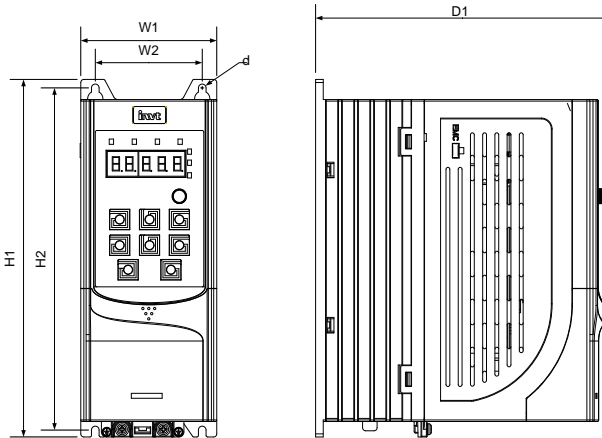

Figure C-6 Wall mounting diagram for 1.5–7.5kW VFD models

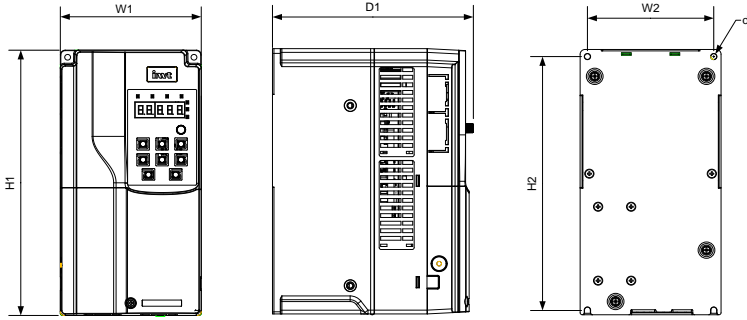

Figure C-7 Wall mounting diagram for 11–45kW VFD models

Table C-1 Wall mounting dimensions for 1.5–45kW VFD models

VFD power	Outline dimensions (mm)			Mounting hole distance (mm)			Hole diameter	Fixing screw
	W1	H1	D1	H2	W2	D2		
1.5–4kW	89	231	193	221	70	-	ø5	M4
5.5–7.5kW	89	259	211.5	248	70	-	ø6	M5
11–15kW	145	280	207	268	130	-	ø6	M5
18.5–22kW	169	320	214	308	154	-	ø6	M5
30–37kW	200	341	214	328.5	185	-	ø6	M5
45kW	250	400	228	380	230	-	ø6	M5

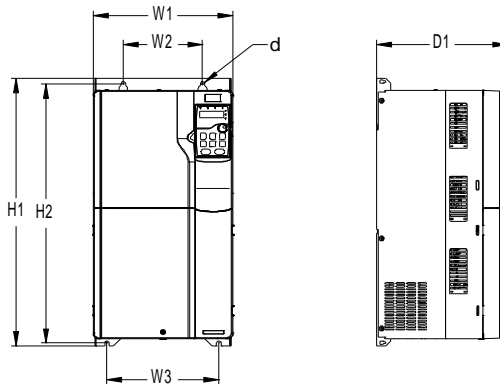

Figure C-8 Wall mounting for 380V 55–90kW VFD models

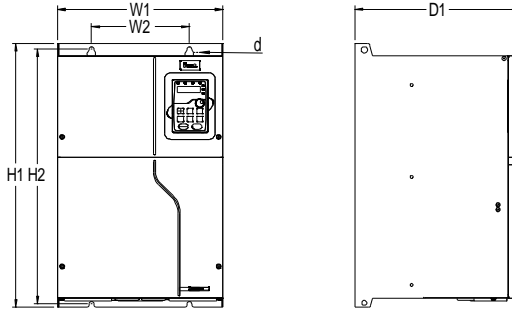

Figure C-9 Wall-mounting diagram for 380V 110–200kW VFD models

Table C-2 Wall mounting dimensions for 380V 55–200kW VFD models

VFD power	Outline dimensions (mm)			Mounting hole distance (mm)			Hole diameter	Fixing screw
	W1	H1	D1	H2	W2	W3		
55–90kW	282	560	264	542	160	226	∅9	M8
110–132kW	338	554	338	534	200	-	∅9.5	M8
160–200kW	338	825	398	800	260	-	∅11	M10

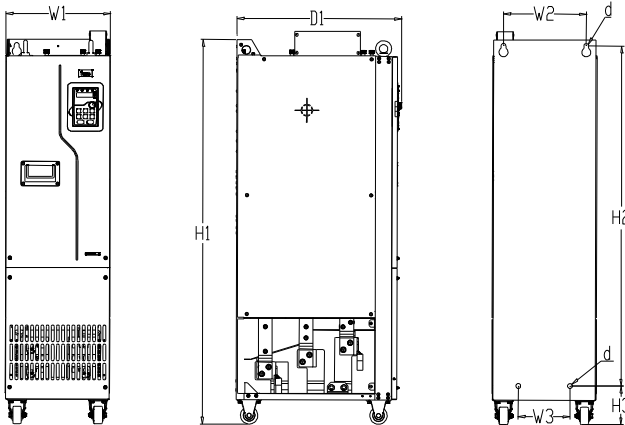

Figure 10-C Wall mounting for 380V 220–250kW VFD models

Table C-3 Wall mounting dimensions for 380V 220–250kW VFD models

VFD power	Outline dimensions (mm)			Mounting hole distance (mm)			Hole diameter	Fixing screw
	W1	H1	D1	H2	W2	W3		
220–250kW	303	1108	477	980	240	150	∅14	M12

C.4.2 Flange installation dimensions

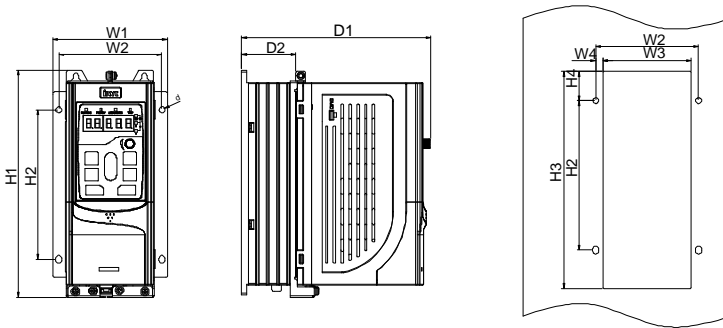

Figure C-11 Flange mounting for 380V 1.5–7.5kW VFD models

Table C-4 Flange mounting dimensions for 380V 1.5–7.5kW VFD models

VFD power	Outline dimensions (mm)			Mounting hole distance (mm)							Hole diameter	Fixing screw
	W1	H1	D1	H2	H3	H4	W2	W3	W4	D2		
1.5–4kW	117	233.5	193	153.5	225	30	105	92.5	6.5	55	∅6	M5
5.5–7.5kW	117	261	211.5	180	250	30	105	92.5	6.5	75	∅6	M5

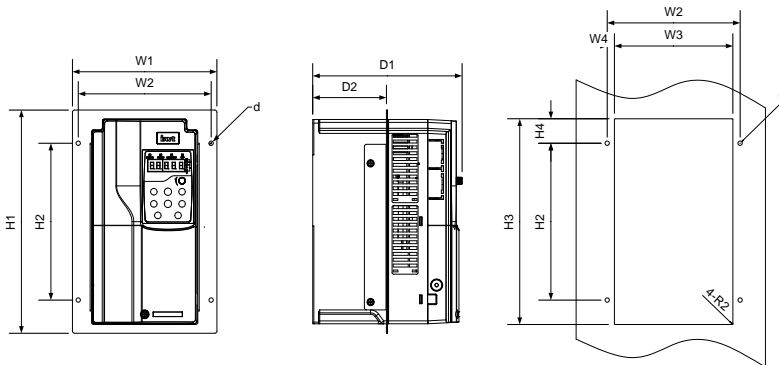

Figure C-12 Flange mounting for 380V 11–22kW VFD models

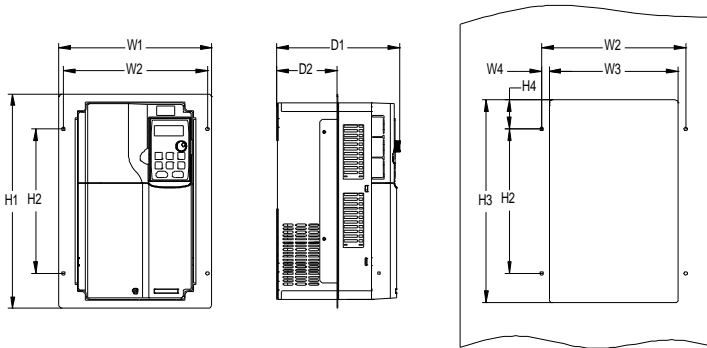

Figure C-13 Flange mounting for 380V 30–90kW VFD models

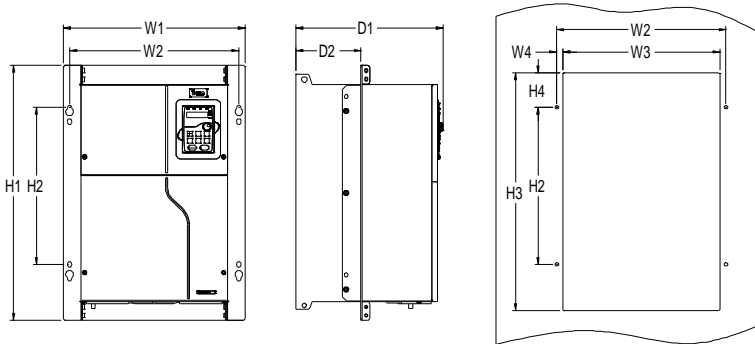
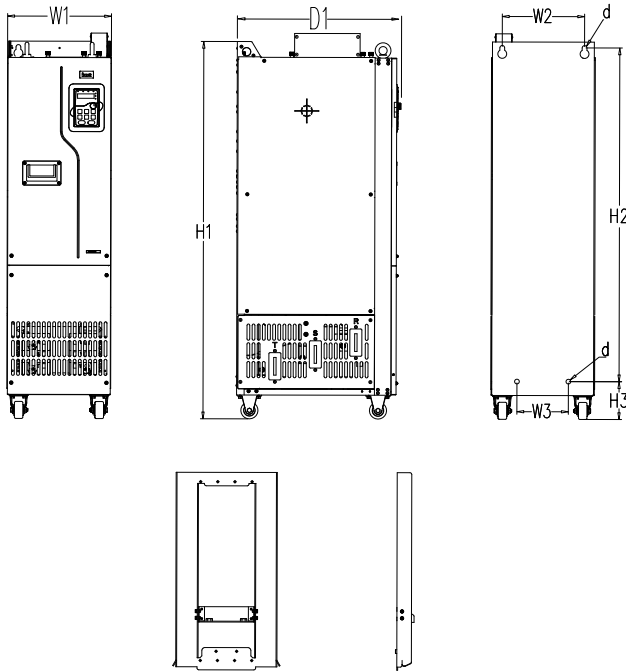

Figure C-14 Flange mounting for 380V 110–200kW VFD models

Table C-5 Flange mounting dimensions for 380V 11–200kW VFD models

VFD power	Outline dimensions (mm)			Mounting hole distance (mm)							Hole diameter	Fixing screw
	W1	H1	D1	H2	H3	H4	W2	W3	W4	D2		
11–15kW	200	306	207	215	282	33.5	184	164	10	102	ø6	M5
18.5–22kW	224	346	214	255	322	33.5	208	189	9.5	108	ø6	M5
30–37kW	266	371	214	250	350.5	50.5	250	224	13	104	ø6	M5
45kW	316	430	228	300	410	55	300	274	13	118.5	ø6	M5
55–90kW	352	580	264	400	570	90	332	306	13	134	ø9	M8
110–132kW	418.5	600	338	370	559	80.5	389.5	361	14	149.5	ø10	M8
160–200kW	428	868	398.5	625	830	80	394	345	24.5	183	ø11	M10

C.4.3 Floor installation dimensions



Base mounting bracket

Figure C-15 Floor mounting for 380V 220–630kW VFD models

Table C-6 380V 220–630kW VFD floor mounting dimensions

VFD power	Outline dimensions (mm)			Mounting hole distance (mm)				Hole diameter (d)	Fixing screw
	W1	H1	D1	H2	H3	W2	W3		
220–250kW	303	1108	477	980	111	240	150	ø14	M12
280–355kW	330	1288	552	1150	122	225	185	ø13	M10
400–500kW	330	1398	552	1280	101	240	200	ø13	M10
560–630kW	380	1450	582	1320	112	240	200	ø14	M12

Note: For details about the base mounting bracket, see Figure C-17 and Table C-8.

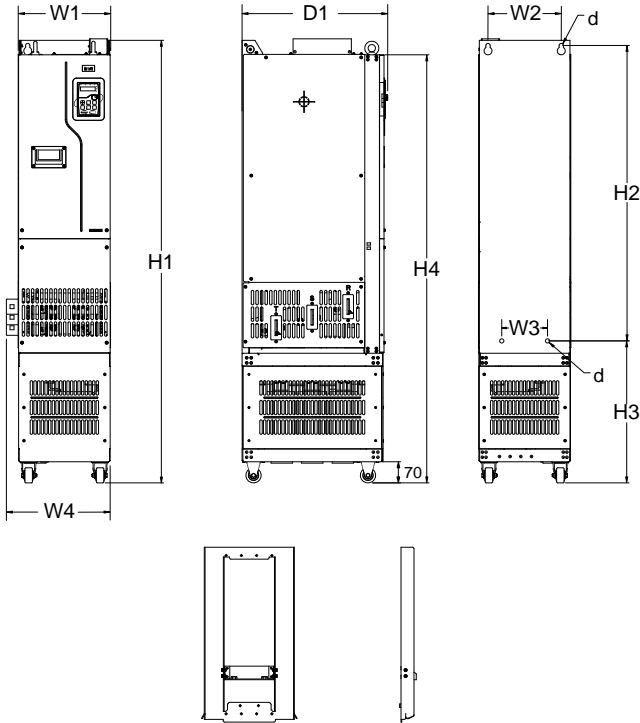

Base mounting bracket

Figure C-16 Mounting diagram for 380V 220-630kW VFDs with output reactors

Table C-7 Floor mounting dimensions for 380V 220-630kW VFDs with output reactors

VFD power	Outline dimensions (mm)				Mounting hole distance (mm)					Hole diameter (d)	Fixing screw
	W1	W4	H1	D1	H2	H3	H4	W2	W3		
220kW-250kW	303	350	1470	477	980	471	1420	240	150	ø14	M12
280kW-355kW	330	429	1619	552	1150	453	1571	225	185	ø13	M10
400kW-500kW	330	430	1729	552	1280	432	1681	240	200	ø13	M10
560kW-630kW	380	480	1780	582	1320	442	1730	240	200	ø14	M12

Note: For details about the base mounting bracket, see Figure C-17 and Table C-8.

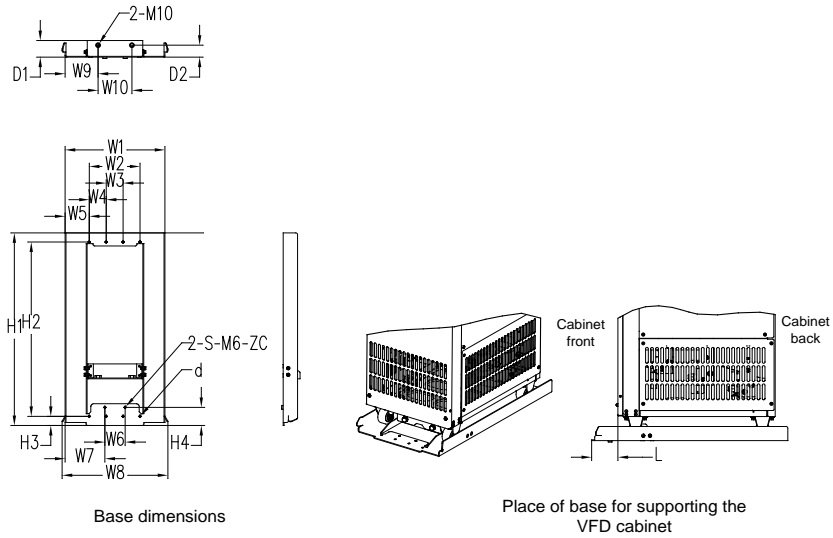

Figure C-17 380V 220–630kW VFD base bracket dimensions and mounting dimensions

Table C-8 380V 220–630kW VFD base bracket dimensions

VFD power	W1	W2	W3	W4	W5	W6	W7	W8	W9	W10	H1	H2	H3	H4	D1	D2	d	Screw	L
220–250kW	295	150	50	50	71.5	60	117.5	313	97.5	100	580	525	27.5	54.5	50	36	ø6	M5 self-tapping screw	77.5
280–315kW	321	150	50	50	84.5	60	130.5	339	110.5	100	580	525	27.5	54.5	46	33.5	ø6		25.5
355–500kW	321	150	50	50	84.5	60	130.5	339	110.5	100	580	525	27.5	54.5	46	33.5	ø6		25
560–630kW	380	150	50	50	115	60	160	398	140	100	615	575	25	55	48.5	32.5	ø6		19

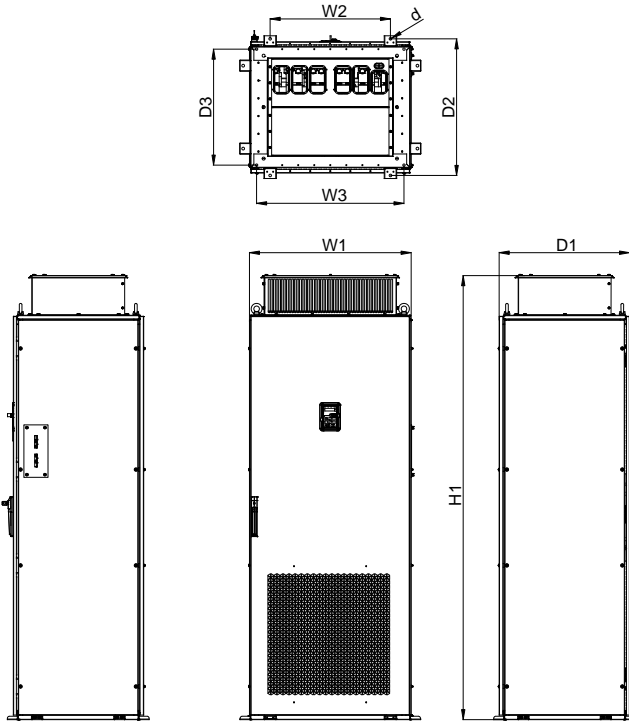

Figure C-18 Mounting diagram for 380V 710–800kW cabinets

Table C-9 Floor mounting dimensions for 380V 710–800kW cabinets

VFD power	Outline dimensions (mm)			Mounting hole distance (mm)				Hole diameter	Fixing screw
	W1	H1	D1	W2	W3	D2	D3		
710–800kW	806	2200	650	600	735	677	575	∅13	M12

Appendix D Optional peripheral accessories

This chapter describes how to select optional accessories for the VFD.

D.1 Wiring of peripheral accessories

The following figure shows the external wiring of the VFD.

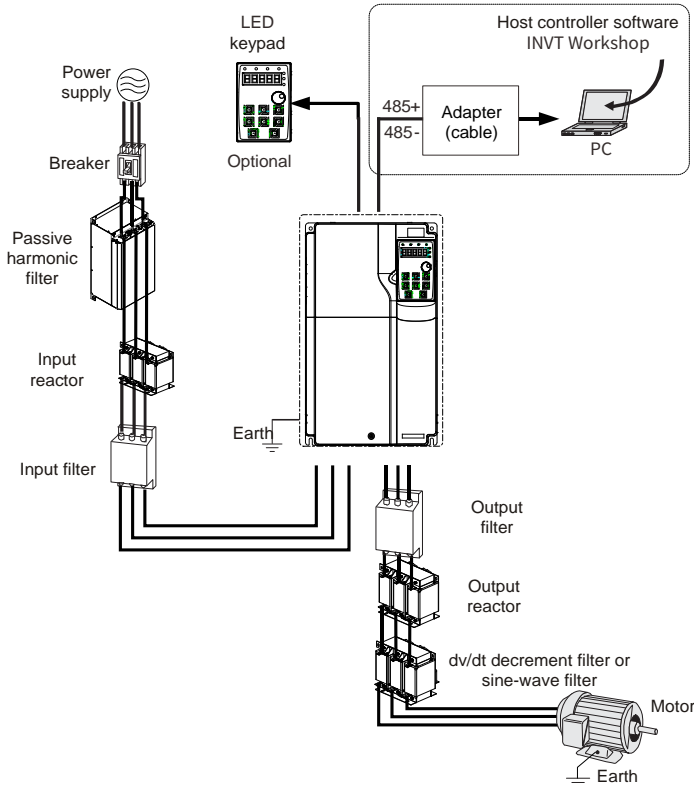

Note: You can choose the optional built-in DC reactor, which will be installed at the factory before delivery.









Image	Name	Description
	Cable	Accessory for signal transmission.
	Breaker	Device for electric shock prevention and protection against short-to-ground that may cause current leakage and fire. Select residual-current circuit breakers (RCCBs) that are applicable to VFDs and can restrict high-order harmonics, and

Image	Name	Description
		of which the rated sensitive current for one VFD is larger than 30mA.
	Passive harmonic filters	Device used to reduce the current distortion rate and harmonic content, thereby improving the power factor.
	Input reactor	Device used to prevent instantaneous high currents from flowing into the input power circuit and damaging rectifier components when high voltage is input from the power grid. Additionally, it can improve the power factor on the input side.
	Input filter	Device that restricts the electromagnetic interference generated by the VFD and transmitted to the public grid through the power cable. Install as close to the input terminal of the VFD as possible.
	Output filter	Device used to suppress interference generated from the wiring on the output side of the VFD. Install as close to the output terminal of the VFD as possible.
	Output reactor	Device used to extend the effective transmission distance of the VFD and effectively suppress instantaneous high voltage generated when the IGBT module of the VFD switches.
	dv/dt decrement filters	Device used to suppress voltage spikes, reduce traveling waves in long cables, and reflect dv/dt transient voltages, thereby reducing motor eddy current losses and noise, and providing motor insulation protection.
	Sine filters	Device used to suppress and absorb high-order harmonic currents derived from switching frequency ripple currents, correcting the waveform to approximate a sine wave, significantly extending the length of the output cable, reducing motor eddy current losses and noise, and protecting motor insulation.

D.2 Power supply

See chapter 4 Installation guidelines.

	Ensure that the voltage class of the VFD is consistent with that of the grid.
---	---

D.3 Cable

D.3.1 Power cable

The sizes of the input power cables and motor cables must comply with local regulations.

- ✧ The input power cables and motor cables must be able to carry the corresponding load currents.
- ✧ The maximum temperature margin of the motor cables in continuous operation cannot be lower than 70°C.
- ✧ The conductivity of the PE grounding conductor is the same as that of the phase conductor, that is, the cross-sectional areas are the same.
- ✧ For details about the EMC requirements, see Appendix B Technical data.

To meet the EMC requirements stipulated in the CE standards, you must use symmetrical shielded cables as motor cables (as shown in the following figure).

Four-core cables can be used as input cables, but symmetrical shielded cables are recommended. Compared with four-core cables, symmetrical shielded cables can reduce electromagnetic radiation as well as the current and loss of the motor cables.

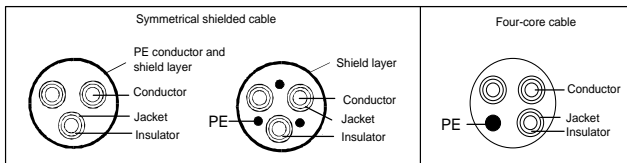

Note: If the electrical conductivity of the motor cable shield layer does not meet the requirements, a separate PE conductor must be used.

To protect the conductors, the cross-sectional area of the shielded cables must be the same as that of the phase conductors if the cable and conductor are made of materials of the same type. This reduces grounding resistance, and thus improves impedance continuity.

To effectively restrict the emission and conduction of radio frequency (RF) interference, the conductivity of the shielded cable must be at least 1/10 of the conductivity of the phase conductor. This requirement can be well met by a copper or aluminum shield layer. Figure D-1 shows the min. requirement on motor cables of VFD. The cable must consist of a layer of spiral-shaped copper strips. The denser the shield layer is, the more effectively the electromagnetic interference is restricted.

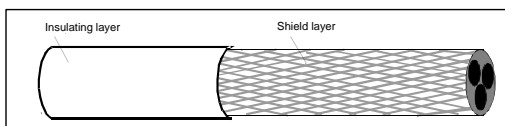

Figure D-1 Cable cross section

D.3.2 Control cable

All analog control cables and cables used for frequency input must be shielded cables. Analog signal cables need to be double-shielded twisted-pair cables (as shown in figure a in Figure D-2). Use one separate shielded twisted pair for each signal. Do not use the same ground wire for different analog signals.

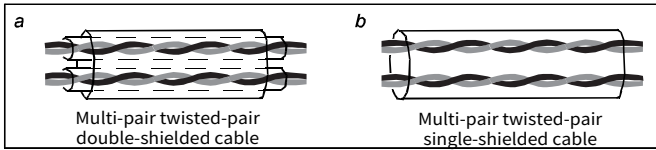

Figure D-2 Power cable arrangement

For low-voltage digital signals, double-shielded cables are recommended, but shielded or unshielded twisted pairs (as shown in figure b in Figure D-2) also can be used. For frequency signals, however, only shielded cables can be used.

Relay cables need to be those with metal braided shield layers.

Keypads need to be connected by using network cables. In complicated electromagnetic environments, shielded network cables are recommended.

Note: Analog signals and digital signals cannot use the same cables, and their cables must be arranged separately.

Dielectric withstand tests have been performed between the main circuit and housing of each VFD before delivery. In addition, the VFD has the internal voltage limiting circuit, which can automatically cut off the test voltage. Do not perform any voltage withstand or insulation resistance tests, such as high-voltage insulation tests or using a megameter to measure the insulation resistance, on the VFD or its components.

Note: Before connecting the input power cable of the VFD, check the insulation conditions of the cable according to local regulations.

D.3.3 Recommended cable size

Table D-1 Recommended cable size

Rated power (kW)	R, S, T / U, V, W / (+), (-)		PE		Fastening torque (N·m)
	Recommended cable (BVR) mm ²	Recommended connection terminal model	Recommended cable (BVR) mm ²	Recommended connection terminal model	
1.5	1	TNR1.25-4	1	TNR1.25-4	1.2–1.5
2.2	1	TNR1.25-4	1	TNR1.25-4	1.2–1.5
4	1.5	TNR1.25-4	1.5	TNR1.25-4	1.2–1.5
5.5	2.5	TNR2-4	2.5	TNR2-4	1.2–1.5
7.5	2.5	TNR2-4	2.5	TNR2-4	1.2–1.5
11	4	TNR3.5-5	4	TNR3.5-5	2–2.5
15	6	TNR5.5-5	6	TNR5.5-5	2–2.5
18.5	10	TNR8-5	10	TNR8-5	2–2.5
22	16	TNR14-5	16	TNR14-5	2–2.5
30	16	GTNR16-6	16	GTNR16-5	3.5

Rated power (kW)	R, S, T / U, V, W / (+), (-)		PE		Fastening torque (N·m)
	Recommended cable (BVR) mm ²	Recommended connection terminal model	Recommended cable (BVR) mm ²	Recommended connection terminal model	
37	25	GTNR25-6	16	GTNR16-5	3.5
45	25	GTNR25-6	16	GTNR16-5	3.5
55	35	GTNR35-8	16	GTNR16-6	9-11
75	50	GTNR50-8	25	GTNR25-6	9-11
90	70	GTNR70-8	35	GTNR35-6	9-11
110	95	GTNR95-12	50	GTNR50-8	31-40
132	95	GTNR95-12	50	GTNR50-8	31-40
160	150	GTNR150-12	70	GTNR70-8	31-40
185	185	GTNR185-12	95	GTNR95-8	31-40
200	185	GTNR185-12	95	GTNR95-8	31-40
220	2x95	GTNR95-12	95	GTNR95-12	31-40
250	2x95	GTNR95-12	95	GTNR95-12	31-40
280	2x150	GTNR150-12	150	GTNR150-12	31-40
315	2x150	GTNR150-12	150	GTNR150-12	31-40
355	2x185	GTNR185-12	185	GTNR185-12	31-40
400	2x185	GTNR185-16	2x120	GTNR120-12	92-100
450	2x240	GTNR240-16	2x150	GTNR150-12	92-100
500	2x300	GTNR300-16	2x150	GTNR150-12	92-100
560	4x150	GTNR150-12	2x150	GTNR150-12	31-40
630	4x150	GTNR150-12	2x150	GTNR150-12	31-40
710	4x150	GTNR150-12	2x150	GTNR150-12	31-40
800	4x150	GTNR150-12	2x150	GTNR150-12	31-40

Copper pipe terminals for cables (GTNR)

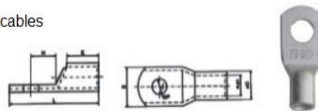

Round bare terminals (TNR)



GTNR terminal brand: Suzhou Yuanli (The model varies with the brand.)

TNR terminal brand: Suzhou Yuanli (The model varies with the brand.)

Table D-2 Recommended cable size (Compliant with UL standards)

Rated power (kW)	R, S, T / U, V, W / (+), (-)		PE		Fastening torque (N·m)
	Recommended cable size (UL) AWG/Kcmil	Recommended connection terminal model	Recommended cable size (UL) AWG/Kcmil	Recommended connection terminal model	
1.5	16	TLK1.5-4	16	TLK1.5-4	1.2–1.5
2.2	16	TLK1.5-4	16	TLK1.5-4	1.2–1.5
4	14	TLK2.5-4	14	TLK2.5-4	1.2–1.5
5.5	14	TLK2.5-4	14	TLK2.5-4	1.2–1.5
7.5	12	TLK4-4	12	TLK4-4	1.2–1.5
11	10	TLK6-5	10	TLK6-5	2–2.5
15	8	TLK10-5	8	TLK10-5	2–2.5
18.5	6	TLK16-5	6	TLK16-5	2–2.5
22	4	TLK25-5	4	TLK25-5	2–2.5
30	4	TLK25-6	4	TLK25-5	3.5
37	3	TLK25-6	4	TLK25-5	3.5
45	3	TLK25-6	4	TLK25-5	3.5
55	2	TLK35-8	4	TLK25-6	9–11
75	1/0	TLK50-8	3	TLK25-6	9–11
90	3/0	TLK95-8	2	TLK35-6	9–11
110	4/0	TLK120-12	1/0	TLK50-8	31–40
132	4/0	TLK120-12	1/0	TLK50-8	31–40
160	300	TLK150-12	3/0	TLK95-8	31–40
185	400	TLK240-12	4/0	TLK120-8	31–40
200	400	TLK240-12	4/0	TLK120-8	31–40
220	2×4/0	TLK120-12	4/0	TLK120-12	31–40
250	2×4/0	TLK120-12	4/0	TLK120-12	31–40
280	2×300	TLK150-12	300	TLK150-12	31–40
315	2×300	TLK150-12	300	TLK150-12	31–40
355	2×400	TLK240-12	400	TLK240-12	31–40
400	2×400	SQNBS200-16	2×250	TLK150-12	96
450	2×500	SQNBS250-16	2×300	TLK150-12	96
500	2×600	SQNBS325-16	2×300	TLK150-12	96
560	4×300	TLK150-12	2×300	TLK150-12	31–40
630	4×300	TLK150-12	2×300	TLK150-12	31–40
710	4×400	TLK240-12	2×400	TLK150-12	31–40
800	4×400	TLK240-12	2×400	TLK150-12	31–40



TLK terminal



SQNBS narrow-head terminal

TLK terminal brand: KST (The model varies with the brand.)

SQNBS narrow-head terminal brand: KST (The model varies with the brand.)

Note:

- ✧ If you select a cable model larger than a recommended model in the table, check whether the wiring terminal width exceeds the allowed width in 4.3.2 Main circuit terminals.
- ✧ If yes, select an SG narrow-head terminal and matching cable since an SG narrow-head terminal has smaller width.
- ✧ The cables recommended for the main circuit can be used in scenarios where the ambient temperature is lower than 40°C, the wiring distance is shorter than 100m, and the current is the rated current.
- ✧ The terminals (+) and (-) are used by multiple VFDs to share the DC bus.

D.3.4 Cable arrangement

Motor cables must be arranged away from other cables. The motor cables of several inverters can be arranged in parallel. It is recommended that you arrange the motor cables, input power cables, and control cables separately in different trays. The output dv/dt of the inverters may increase electromagnetic interference on other cables. Do not arrange other cables and the motor cables in parallel.

If a control cable and power cable must cross each other, ensure that the angle between them is 90°.

The cable trays must be connected properly and well grounded. Aluminum trays can implement local equipotential.

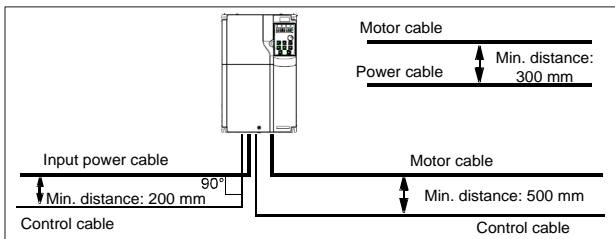

Figure D-3 Cable routing distance

D.3.5 Insulation inspection

Check the motor and the insulation conditions of the motor cable before running the motor.

1. Ensure that the motor cable is connected to the motor, and then remove the motor cable from the U, V, and W output terminals of the VFD.
2. Use a megohmmeter of 500V DC to measure the insulation resistance between each phase conductor and the protection grounding conductor. For details about the insulation resistance of the motor, see the description provided by the manufacturer.

Note: The insulation resistance is reduced if it is damp inside the motor. If it may be damp, you need to dry the motor and then measure the insulation resistance again.

D.4 Breaker and electromagnetic contactor

The circuit breaker is mainly used to prevent electric shock accidents and short circuits to the ground that may cause leakage current fire. The electromagnetic contactor is mainly used to control the main circuit power on and off, which can effectively cut off the input power of the VFD in case of system failure to ensure safety.



According to the working principle and structure of breakers, if the manufacturer's regulation is not followed, hot ionized gases may escape from the breaker enclosure when a short-circuit occurs. To ensure safe use, exercise extra caution when installing and placing the breaker. Follow the manufacturer's instructions.

Table D-3 Ratings for AC 3PH 380V VFD models

Rated power (kW)	Breaker rated current (A)	Fast-acting fuse rated current (A)	Contactor rated current (A)
1.5	6	10	9
2.2	10	10	9
4	20	20	18
5.5	25	32	25
7.5	32	40	32
11	50	50	38
15	50	63	50
18.5	63	80	65
22	80	80	80
30	100	125	80
37	125	125	98
45	140	150	115
55	180	200	150
75	225	250	185
90	250	300	225
110	315	350	265

Rated power (kW)	Breaker rated current (A)	Fast-acting fuse rated current (A)	Contactora rated current (A)
132	400	400	330
160	500	500	400
185	500	600	400
200	630	600	500
220	630	700	500
250	700	800	630
280	800	1000	630
315	1000	1000	800
355	1000	1000	800
400	1000	1200	1000
450	1250	1200	1000
500	1250	1400	1000
560	1250	1600	1200
630	1250	1600	1200
710	1600	2000	1600
800	1600	2000	1600

Note: The accessory specifications described in the preceding table are ideal values. You can select accessories based on the actual market conditions, but try not to use those with lower values.

D.5 Harmonic filters

To enhance grid protection, reduce harmonic interference from the VFD to the grid, and improve input power factor, consider configuring external DC reactors, input reactors, or passive harmonic filters based on your specific application needs.

If you want to use long cables between the VFD and the motor, select external output reactors, dv/dt attenuation filters, or sine-wave filters based on the motor cable length. This helps mitigate excessive dv/dt, reducing voltage stress on the motor windings as well as protecting them, and extending the motor's lifespan. Refer to the following table for recommended output filter selections according to motor cable length.

Table D-4 Reactor model selection

Rated power (kW)	Input reactor	Output reactor
1.5	GDL-ACL0005-4CU	GDL-OCL0005-4CU
2.2	GDL-ACL0006-4CU	GDL-OCL0006-4CU
4	GDL-ACL0014-4CU	GDL-OCL0010-4CU
5.5	GDL-ACL0020-4CU	GDL-OCL0014-4CU
7.5	GDL-ACL0025-4CU	GDL-OCL0020-4CU
11	GDL-ACL0035-4AL	GDL-OCL0025-4CU
15	GDL-ACL0040-4AL	GDL-OCL0035-4AL

Rated power (kW)	Input reactor	Output reactor
18.5	GDL-ACL0051-4AL	GDL-OCL0040-4AL
22	GDL-ACL0051-4AL	GDL-OCL0050-4AL
30	GDL-ACL0070-4AL	GDL-OCL0060-4AL
37	GDL-ACL0090-4AL	GDL-OCL0075-4AL
45	GDL-ACL0110-4AL	GDL-OCL0092-4AL
55	GDL-ACL0150-4AL	GDL-OCL0115-4AL
75	GDL-ACL0150-4AL	GDL-OCL0150-4AL
90	GDL-ACL0220-4AL	GDL-OCL0220-4AL
110	GDL-ACL0220-4AL	GDL-OCL0220-4AL
132	GDL-ACL0265-4AL	GDL-OCL0265-4AL
160	GDL-ACL0330-4AL	GDL-OCL0330-4AL
185	GDL-ACL0390-4AL	GDL-OCL0400-4AL
200	GDL-ACL0390-4AL	GDL-OCL0400-4AL
220	GDL-ACL0450-4AL	GDL-OCL0450-4AL
250	GDL-ACL0500-4AL	GDL-OCL0500-4AL
280	GDL-ACL0500-4AL	GDL-OCL0560-4AL
315	GDL-ACL0580-4AL	GDL-OCL0660-4AL
355	GDL-ACL0660-4AL	GDL-OCL0660-4AL
400	GDL-ACL0715-4AL	GDL-OCL0720-4AL
450	GDL-ACL0840-4AL	GDL-OCL0820-4AL
500	GDL-ACL1000-4AL	GDL-OCL1000-4AL
560	2xGDL-ACL0500-4AL	2xGDL-OCL0560-4AL
630	2xGDL-ACL0580-4AL	2xGDL-OCL0660-4AL
710	2xGDL-ACL0660-4AL	2xGDL-OCL0660-4AL
800	2xGDL-ACL0715-4AL	2xGDL-OCL0720-4AL

Note:

- ✧ The rated input voltage drop of input reactor is designed to $\geq 1.5\%$.
- ✧ The rated output voltage drop of output reactor is designed to 1%.
- ✧ The preceding table lists only external accessories. You need to specify whether external or built-in accessories are needed in your purchase order.
- ✧ For the selection of accessories with different material requirements than those listed above, please refer to the low-voltage VFD GDL series filter option brochure.

Table D-5 Filter model selection

Rated power (kW)	Input filter		Output filter	
	Passive harmonic filters		dv/dt decrement filters	Sine filters
1.5	GDL-H0006-4AL		GDL-DUL0005-4CU	GDL-OSF0005-4AL
2.2	GDL-H0006-4AL		GDL-DUL0005-4CU	GDL-OSF0005-4AL
4	GDL-H0014-4AL		GDL-DUL0010-4CU	GDL-OSF0010-4AL
5.5	GDL-H0020-4AL		GDL-DUL0014-4CU	GDL-OSF0014-4AL
7.5	GDL-H0025-4AL		GDL-DUL0020-4CU	GDL-OSF0020-4AL
11	GDL-H0032-4AL		GDL-DUL0025-4CU	GDL-OSF0025-4AL
15	GDL-H0040-4AL		GDL-DUL0032-4CU	GDL-OSF0032-4AL
18.5	GDL-H0047-4AL		GDL-DUL0040-4AL	GDL-OSF0040-4AL
22	GDL-H0056-4AL		GDL-DUL0045-4AL	GDL-OSF0045-4AL
30	GDL-H0070-4AL		GDL-DUL0060-4AL	GDL-OSF0060-4AL
37	GDL-H0080-4AL		GDL-DUL0075-4AL	GDL-OSF0075-4AL
45	GDL-H0100-4AL		GDL-DUL0100-4AL	GDL-OSF0095-4AL
55	GDL-H0130-4AL		GDL-DUL0120-4AL	GDL-OSF0120-4AL
75	GDL-H0160-4AL		GDL-DUL0150-4AL	GDL-OSF0150-4AL
90	GDL-H0190-4AL		GDL-DUL0180-4AL	GDL-OSF0180-4AL
110	GDL-H0225-4AL		GDL-DUL0220-4AL	GDL-OSF0220-4AL
132	GDL-H0265-4AL		GDL-DUL0260-4AL	GDL-OSF0260-4AL
160	GDL-H0320-4AL		GDL-DUL0320-4AL	GDL-OSF0320-4AL
185	GDL-H0400-4AL		GDL-DUL0400-4AL	GDL-OSF0400-4AL
200	GDL-H0400-4AL		GDL-DUL0400-4AL	GDL-OSF0400-4AL
220	GDL-H0485-4AL		GDL-DUL0480-4AL	GDL-OSF0480-4AL
250	GDL-H0485-4AL		GDL-DUL0480-4AL	GDL-OSF0480-4AL
280	GDL-H0545-4AL		GDL-DUL0540-4AL	GDL-OSF0600-4AL
315	GDL-H0610-4AL		GDL-DUL0600-4AL	GDL-OSF0600-4AL
355	GDL-H0800-4AL		GDL-DUL0800-4AL	GDL-OSF0800-4AL
400	GDL-H0800-4AL		GDL-DUL0800-4AL	GDL-OSF0800-4AL
450	GDL-H1000-4AL		GDL-DUL1000-4AL	GDL-OSF1000-4AL
500	GDL-H1000-4AL		GDL-DUL1000-4AL	GDL-OSF1000-4AL
560	2xGDL-H0545-4AL		2xGDL-DUL0540-4AL	2xGDL-OSF0600-4AL
630	2xGDL-H0610-4AL		2xGDL-DUL0600-4AL	2xGDL-OSF0600-4AL
710	2xGDL-H0800-4AL		2xGDL-DUL0800-4AL	2xGDL-OSF0800-4AL
800	2xGDL-H0800-4AL		2xGDL-DUL0800-4AL	2xGDL-OSF0800-4AL

Note:

- ◇ The preceding table lists only external accessories. You need to specify whether external or built-in accessories are needed in your purchase order.

- ◇ For the selection of accessories with different material requirements than those listed above, please refer to the low-voltage VFD GDL series filter option brochure.

D.6 EMC filter

Table D-6 EMC filter model selection

Rated power (kW)	Input filter	Output filter
1.5	FLT-P04006L-B	FLT-L04006L-B
2.2	FLT-P04006L-B	FLT-L04006L-B
4	FLT-P04016L-B	FLT-L04016L-B
5.5	FLT-P04032L-B	FLT-L04032L-B
7.5	FLT-P04032L-B	FLT-L04032L-B
11	FLT-P04045L-B	FLT-L04045L-B
15	FLT-P04045L-B	FLT-L04045L-B
18.5	FLT-P04065L-B	FLT-L04065L-B
22	FLT-P04065L-B	FLT-L04065L-B
30	FLT-P04100L-B	FLT-L04065L-B
37	FLT-P04100L-B	FLT-L04100L-B
45	FLT-P04100L-B	FLT-L04100L-B
55	FLT-P04150L-B	FLT-L04150L-B
75	FLT-P04240L-B	FLT-L04150L-B
90	FLT-P04240L-B	FLT-L04240L-B
110	FLT-P04240L-B	FLT-L04240L-B
132	FLT-P04400L-B	FLT-L04400L-B
160	FLT-P04400L-B	FLT-L04400L-B
185	FLT-P04400L-B	FLT-L04400L-B
200	FLT-P04400L-B	FLT-L04400L-B
220	FLT-P04600L-B	FLT-L04600L-B
250	FLT-P04600L-B	FLT-L04600L-B
280	FLT-P04600L-B	FLT-L04600L-B
315	FLT-P04800L-B	FLT-L04800L-B
355	FLT-P04800L-B	FLT-L04800L-B
400	FLT-P04800L-B	FLT-L04800L-B
450	FLT-P041000L-B	FLT-L041000L-B
500	FLT-P041000L-B	FLT-L041000L-B
560	2*FLT-P04600L-B	2*FLT-L04600L-B
630	2*FLT-P04800L-B	2*FLT-L04800L-B
710	2xFLT-P04800L-B	2xFLT-L04800L-B
800	2xFLT-P04800L-B	2xFLT-L04800L-B

D.7 List of other optional accessories

Name	Specifications	Function	Remarks
External LED keypad	BOP-270	Externally connected LED display and operation panel	Applicable to 1.5–22kW models
External LCD keypad	SOP-270	Externally connected LCD display and operation panel	Applicable to all series For details about how to operate the keypad, see chapter 5 in the operation manual for GD350 series high-performance multifunction VFD.
Keypad bracket	GD350-JPZJ	Used to fix the LED or LCD keypad for external connection to the electrical cabinet	Applicable to all series
Keypad protective cover	GD270-JPFH	When the local keypad is externally led, this protective cover prevents dust and foreign objects from entering through the keypad port.	Applicable to 30–630kW models
Rail assembly for cabinet mounting	GD270-DGZJ	Used to mount a VFD in a cabinet, improving mounting efficiency and safety	Applicable to 220–630kW models. For detailed instructions, see section 4.2.3 Cabinet design.
Flange mounting bracket	Consult the manufacturer.	Used to meet the flange mounting needs	Applicable to 1.5–200kW models
External braking unit busbar	-	Used to extend wiring connections when an external braking unit is required.	Applicable to 710–800 kW models.

Appendix E STO function (for -EU models only)

E.1 Safety standards

The product has been integrated with the STO function and complies with the following safety standards.

IEC 61000-6-7	Electromagnetic compatibility (EMC)—Part 7: General standards—Immunity requirements for equipment used in industrial sites to perform safety related functions (functional safety)
IEC 61326-3-1	EMC requirements for measurement, control, and laboratory electrical equipment—Part 31: Immunity requirements for safety related systems and equipment intended to perform safety related functions (functional safety)—General industrial applications
IEC 61508-1	Functional safety of electrical/electronic/programmable electronic safety related systems—Part 1: General requirements
IEC 61508-2	Functional safety of electrical/electronic/programmable electronic safety related systems—Part 2: Requirements for electrical/electronic/programmable electronic safety related systems
IEC/EN 61800-5-2	Adjustable speed electrical power drive systems Part 5-2: Safety requirements—Function
IEC/EN 62061	Safety of machinery—Safety-related functional safety of electrical, electronic, and programmable electronic control systems
EN/ISO 13849-1	Safety of machinery—Safety related parts of control systems—Part 1: General principles for design
EN/ISO 13849-2	Safety of machinery—Safety related parts of control systems—Part 2: Verification

Safety standard related data is as follows.

Code	Definition	Standard	Characteristics
SIL	Safety integrity level	IEC 61508 IEC 62061	SIL3
PFH	Probability of failure per hour	IEC 61508	2.87×10^{-10}
HFT	Hardware fault tolerance	IEC 61508	1
SFF	Safe failure fraction	IEC 61508	97.59%
DC	Diagnosis coverage	ISO 13849-1	Greater than 90%
Cat.	Category	ISO 13849-1	3

E.2 Safety function description

■ STO function principle description

STO (Safe Torque Off) function turns off the drive output by shutting down the drive signal, cutting off the electrical power supply to the motor and thus stopping the outward torque output (see Figure E-3). When STO is activated, this function prevents the motor from accidentally starting if the motor is in static state. If the motor is rotating, it will continue to rotate by inertia until it comes to rest. If the motor has a brake, the brake closes immediately.

Note:

- In normal working mode, you are not recommended to use the STO function to stop the VFD running. The STO function cannot effectively prevent sabotage or misuse. If the STO function is used to stop a running VFD, the VFD will disconnect the power supply to the motor, and the motor will coast to stop. If the consequences caused by this action are unacceptable, related stop modes should be used to stop the VFD and mechanical equipment.
- When using a permanent magnet, reluctance, or nonsalient pole induction motor, even if the STO function is activated, there is still a possible failure mode (although the possibility is very low) that prevents the two power devices of the VFD from conducting. The drive system can output a uniform torque, which can rotate the permanent magnet motor shaft by a maximum electrical angle of 180°, or the nonsalient pole induction motor or reluctance motor shaft by an electrical angle of 90°. This possible failure mode must be allowed during the design of the machine system. Maximum motor shaft rotation angle = Electrical angle of 360°/Number of motor pole pairs.
- The STO function cannot replace the emergency stop function. When no other measures are taken, the power supply of the VFD cannot be cut off in an emergency.
- The STO function has priority over all other functions of the VFD.
- Although the STO function can reduce known hazardous conditions, it does not eliminate all potential hazards.
- Designing safety related systems requires professional safety knowledge. To ensure the safety of a complete control system, design the system according to the required safety principles. A single subsystem with the STO function, although intentionally designed for safety related applications, it cannot guarantee the safety of the entire system.

■ Emergency stop function description

When the emergency stop function is used in equipment, it mainly allows operators to take timely actions to prevent accidents in unexpected conditions. Its design may not necessarily be complex or intelligent, but it may use simple electromechanical devices to initiate a controlled rapid stop by cutting off the power supply or other means (such as dynamic or regenerative braking).

E.3 Risk assessment

1. Before using the STO function, a risk assessment needs to be conducted on the drive system to ensure compliance with the required safety standards.
2. There may also be some other risks when the device is operating with safety functions. Therefore, safety must always be considered when conducting risk assessments.
3. If an external force (such as vertical axis gravity) is applied while the safety function is in operation, the motor will rotate. A separate mechanical brake must be provided to secure the motor.
4. If the drive fails, the motor can operate within the range of 180 degrees, ensuring safety even in dangerous situations.
5. The rotation number and moving distance of each type of motor are as follows:
 - Rotating motor: can rotate up to 1/6 (of the motor shaft rotation angle).
 - Drive motor: can rotate up to 1/20 (of the motor shaft rotation angle).
 - Linear servo motor: can move up to 30mm.

E.4 STO wiring

In the factory, the STO function terminals +24V, H1, and H2 have been shorted.

The wiring requirements are as follows:

1. When using the STO function of the VFD, remove the jumpers between +24V and H1 and between +24V and H2.
2. When the VFD is in normal operation, close K (the switches or relays).

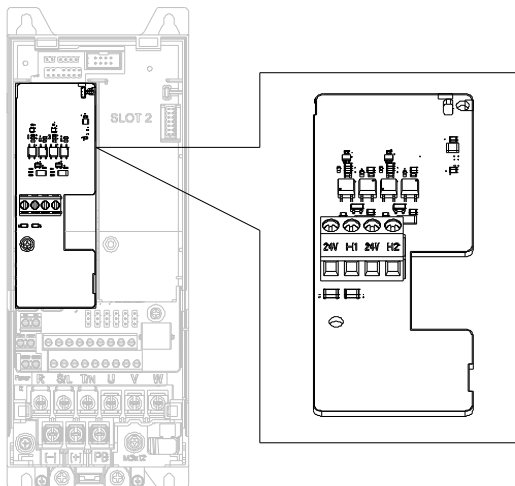

Figure E-1 STO function terminal diagram for 1.5–7.5kW models (SLOT1 position)

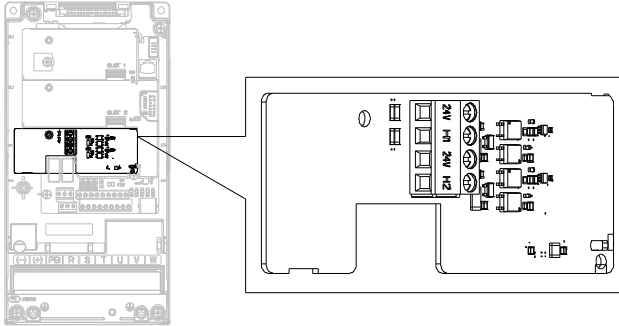

Figure E-2 STO function terminal diagram for 11–500kW models (SLOT3 position)

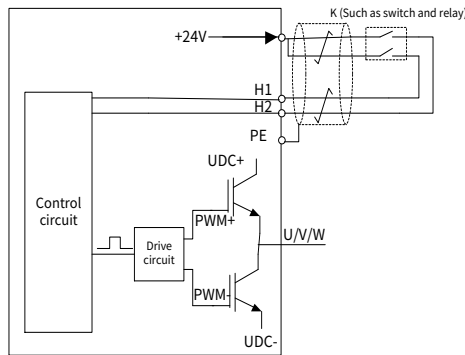

Figure E-3 STO function circuit wiring

Note:

- The symbol K in the preceding figure can represent components such as manual operation switch, emergency stop switch, safety relay, and safety PLC contact.
- The opening or closing of safety switch contact must be within 200.
- The maximum length of the double-shielded twisted pair cable between the VFD and safety switch is 25m.
- The cable shield layer should be connected to the PE terminal of the VFD.
- When the STO function is enabled, the switch or relay is opened. If the VFD stops output, the keypad displays "STO".

E.5 STO function terminal description

STO function terminals are listed in the following table.

Terminal symbol	Function description
+24V	Voltage range: 24V±15% To disable the STO function, short +24V to H1 and to H2.
H1	Voltage in STO action mode: 0V < H1 and H2 < 5V Voltage in STO cut-off mode: 13V < H1 and H2 < 30V
H2	Input current: 5mA STO function channel signal input

Note: For the 1.5–7.5kW -EU models, the extended interface SLOT1 will be occupied due to the H1/H2 terminals, that is, 1.5–7.5kW -EU models only support extended interface SLOT2.

E.6 STO function logic table

The function logics of H1 and H2 and keypad display are listed in the following table.

H1	H2	VFD status	Keypad display	Fault description
H1 closed	H2 closed	Normal running	No exception displayed	-
H1 opened	H2 opened	Torque output off	STO	Safe torque off (STO)
H1 opened	H2 closed	Torque output off	STL1	H1 is abnormal.
H1 closed	H2 opened	Torque output off	STL2	H2 is abnormal.

Note: STL3 indicates both H1 and H2 are abnormal.

E.7 STO channel delay description

The following table describes the trigger and indication delay of the STO channels.

Table E-1 STO channel trigger and indication delay

STO mode	STO trigger delay ¹ and indication delay ²
STO fault: STL1	Trigger delay < 10ms Indication delay < 280ms
STO fault: STL2	Trigger delay < 10ms Indication delay < 280ms
STO fault: STL3	Trigger delay < 10ms Indication delay < 280ms
STO fault: STO	Trigger delay < 10ms Indication delay < 100ms

¹: STO trigger delay: time interval between trigger the STO function and switching off the drive output

²: STO instruction delay: Time interval between trigger the STO function and STO output state indication

E.8 Acceptance test

Alarm	
	<ul style="list-style-type: none"> • Technical personnel, operators, maintenance and repair personnel must receive relevant training to understand the requirements and principles of safety system design and debugging. • Do not carry out maintenance on the VFD or motor before the power is cut off; otherwise, there may be a risk of electric shock or other electricity generated hazards. • The safety function acceptance test must be carried out by personnel with professional safety function knowledge, and must be recorded and signed by test engineers.

The acceptance test must be carried for the device in the following stages:

1. First starting of safety functions
2. After any safety function related change (including PCB, wiring, component, or setup)
3. After any safety function related maintenance work

The signed acceptance test report must be kept in machine logs. The report should include the documents of startup activities and test results, fault report references and fault solutions. Any new acceptance test conducted due to changes or maintenance should be recorded in the logs.

■ **Acceptance test checklist**

Step	Test	Result
1	Ensure that the VFD can run or stop randomly during commissioning.	
2	Stop the VFD (if it is running), disconnect the input power supply, and isolate the drive from the power cable through the isolation switch.	
3	Check the STO function circuit connection according to the circuit diagram.	
4	Close the isolation switch to connect to the power.	
	Test the STO function as follows when the motor stops: If the VFD is running, send a stop command to it and wait until the motor shaft stops rotating. Disconnect the STO circuit. Then the VFD should enter the safe torque off mode and stop outputting voltage, and the keypad displays "STO".	
	Send a VFD startup command, but the motor does not start. Close the STO circuit. Remove the fault, start the VFD, and ensure that the motor can run properly.	
	Test the STO function as follows when the motor is running: Start the VFD and ensure that the motor runs. Disconnect the STO circuit. Then the VFD should enter the safe torque off mode and stop outputting voltage, and the keypad displays "STO". The motor	

Step	Test	Result
	should stop. Remove the fault, start the VFD, and ensure that the motor keeps the static state. Close the STO circuit. Remove the fault, start the VFD, and ensure that the motor can run properly.	
5	Test and detect the VFD fault. At this time, the motor can be in running or stopped state. Start the VFD and ensure that the motor runs properly. Disconnect H1 and keep H2 closed. If the motor is running, it should coast to stop, and the keypad displays "STL1". Send a VFD startup command, but the motor does not start. Close the STO circuit. At this time, the fault cannot be removed. Power off and restart the VFD, and ensure that the motor can run properly. Disconnect H2 and keep H1 closed. If the motor is running, it should coast to stop, and the keypad displays "STL2". Send a VFD startup command, but the motor does not start. Close the STO circuit. At this time, the fault cannot be removed. Power off and restart the VFD, and ensure that the motor can run properly.	
6	Record and sign the acceptance test report, which indicates the STO function is safe and can be put into service.	

Note:

- If the steps in the acceptance test checklist can be carried out normally without other exceptions, it indicates that the STO functional circuit is normal. If the situations are different from the expected results of the preceding steps or if "E43" is displayed, it indicates that the STO function circuit is abnormal. For details about fault handling, see section 7.5.1 Faults and solutions.
- Fault "STO" can also be manually or automatically reset by setting P08.52.

VFD fault	Fault code displayed	Response time	Reset method
Normal running	No exception displayed	-	-
Torque output off	STO	≤20ms	Press STOP/RST.
Torque output off	STL1	≤20ms	Entire machine re-powered on
Torque output off	STL2	≤20ms	Entire machine re-powered on

Appendix F Efficiency

Table F-1 Power loss and IE class

Model	Relative loss (%)								Standby loss (W)	IE class
	(0;25)	(0;50)	(0;100)	(50;25)	(50;50)	(50;100)	(90;50)	(90;100)		
GD270-1R5-4(-C2)(-EU)	0.78	0.95	1.03	0.86	1.17	1.23	1.35	2.02	13	IE2
GD270-2R2-4(-C2)(-EU)	0.82	0.76	0.55	1.09	1.11	1.07	1.59	1.76	17	IE2
GD270-004-4(-C2)(-EU)	0.74	1.20	1.55	1.15	1.28	1.89	1.45	2.29	16	IE2
GD270-5R5-4(-C2)(-EU)	0.71	0.97	1.32	1.02	1.21	1.83	1.34	2.18	17	IE2
GD270-7R5-4(-C2)(-EU)	0.68	0.78	1.75	0.76	1.03	1.79	1.22	2.06	20	IE2
GD270-011-4(-L1/-C2)(-EU)	0.65	0.89	1.62	0.66	1.37	1.43	1.38	2.28	27	IE2
GD270-015-4(-L1/-C2)(-EU)	0.96	1.30	2.26	0.74	0.90	1.43	0.87	1.49	27	IE2
GD270-018-4(-L1/-C2)(-EU)	0.72	0.95	1.57	1.20	1.46	2.17	1.47	2.26	30	IE2
GD270-022-4(-L1/-C2)(-EU)	0.67	0.87	1.44	1.07	1.29	1.92	1.27	2.04	30	IE2
GD270-030-4(-L1)(-C3)(-EU)	0.71	0.98	1.76	1.22	1.89	2.42	2.17	2.83	30	IE2
GD270-037-4(-L1)(-C3)(-EU)	0.67	0.85	1.60	1.09	1.75	2.37	1.91	2.73	30	IE2
GD270-045-4(-L1)(-C3)(-EU)	0.47	0.62	1.14	1.09	1.27	1.90	1.52	2.02	30	IE2
GD270-055-4(-L1)(-C3)(-EU)	0.42	0.69	1.04	0.98	1.19	1.72	1.45	1.88	31	IE2
GD270-075-4(-L1)(-C3)(-EU)	0.52	0.80	1.35	1.06	1.42	2.10	1.67	2.23	32	IE2
GD270-090-4(-L1)(-C3)(-EU)	0.40	0.72	1.29	0.93	1.31	1.98	1.58	2.11	31	IE2
GD270-110-4(-L1)(-C3)(-EU)	0.42	0.69	1.20	0.84	0.98	1.67	1.27	1.72	33	IE2
GD270-132-4(-L1)(-C3)(-EU)	0.50	0.65	1.28	0.97	1.12	1.74	1.22	1.85	35	IE2
GD270-160-4(-L1)(-EU)	0.61	1.01	1.52	1.37	1.32	2.02	1.42	2.14	37	IE2
GD270-185-4(-L1)(-EU)	0.56	0.95	1.45	1.13	1.19	1.88	1.37	2.07	37	IE2
GD270-200-4(-L1)(-EU)	0.48	0.81	1.33	0.99	1.08	1.78	1.28	1.99	38	IE2
GD270-220-4(-Ln)(-EU)	0.59	0.85	1.76	1.24	1.58	2.61	1.68	2.65	40	IE2
GD270-250-4(-Ln)(-EU)	0.65	0.91	1.86	1.33	1.72	2.79	1.73	2.85	42	IE2
GD270-280-4(-Ln)(-EU)	0.68	0.98	1.92	1.27	1.61	2.54	1.62	2.69	48	IE2
GD270-315-4(-Ln)(-EU)	0.66	0.94	1.88	1.19	1.49	2.45	1.56	2.54	50	IE2
GD270-355-4(-Ln)(-EU)	0.72	1.01	1.87	1.11	1.37	2.30	1.47	2.47	52	IE2
GD270-400-4-Ln(-EU)	0.78	0.82	1.64	1.14	1.38	2.25	1.43	2.31	55	IE2
GD270-450-4-Ln(-EU)	0.75	0.89	1.52	1.08	1.27	2.16	1.37	2.23	58	IE2
GD270-500-4-Ln(-EU)	0.73	0.78	1.40	0.90	1.10	1.90	1.25	2.16	60	IE2
GD270-560-4-Ln(-EU)	0.71	0.82	1.42	1.28	1.48	2.48	1.53	2.52	62	IE2
GD270-630-4-Ln(-EU)	0.69	0.85	1.36	0.93	1.33	2.35	1.41	2.25	65	IE2
GD270-710-4-Ln(-EU)	0.74	0.87	1.39	1.26	1.51	2.53	1.55	2.61	66	IE2
GD270-800-4-Ln(-EU)	0.77	0.83	1.37	1.18	1.49	2.49	1.49	2.33	68	IE2

Note: n = 1 or 3

Table F-2 Rated specifications

Model	Apparent power (kVA)	Rated output power (kW)	Rated output current (A)	Max. working temperature (°C)	Rated power frequency (Hz)	Rated power voltage (V)
GD270-1R5-4(-C2)(-EU)	2.44	1.5	3.7	50°C Derate by 1% for every increase of 1°C when the temperature exceeds 40°C.	50/60Hz Allowed range: 47–63Hz	3PH 380V
GD270-2R2-4(-C2)(-EU)	3.98	2.2	5			
GD270-004-4(-C2)(-EU)	6.2	4	9.5			
GD270-5R5-4(-C2)(-EU)	8.6	5.5	13			
GD270-7R5-4(-C2)(-EU)	12.2	7.5	17			
GD270-011-4(-L1/-C2)(-EU)	16.5	11	25			
GD270-015-4(-L1/-C2)(-EU)	21	15	32			
GD270-018-4(-L1/-C2)(-EU)	24	18.5	38			
GD270-022-4(-L1/-C2)(-EU)	30	22	45			
GD270-030-4(-L1)(-C3)(-EU)	39.5	30	60			
GD270-037-4(-L1)(-C3)(-EU)	49	37	75			
GD270-045-4(-L1)(-C3)(-EU)	60	45	92			
GD270-055-4(-L1)(-C3)(-EU)	75.7	55	115			
GD270-075-4(-L1)(-C3)(-EU)	98.7	75	150			
GD270-090-4(-L1)(-C3)(-EU)	120	90	180			
GD270-110-4(-L1)(-C3)(-EU)	142	110	215			
GD270-132-4(-L1)(-C3)(-EU)	172	132	250			
GD270-160-4(-L1)(-EU)	200	160	305			
GD270-185-4(-L1)(-EU)	217	185	330			
GD270-200-4(-L1)(-EU)	250	200	380			
GD270-220-4(-Ln)(-EU)	280	220	425			
GD270-250-4(-Ln)(-EU)	316	250	460			
GD270-280-4(-Ln)(-EU)	349	280	530			
GD270-315-4(-Ln)(-EU)	395	315	600			
GD270-355-4(-Ln)(-EU)	425	355	650			
GD270-400-4-Ln(-EU)	474	400	720			
GD270-450-4-Ln(-EU)	540	450	820			
GD270-500-4-Ln(-EU)	566	500	860			
GD270-560-4-Ln(-EU)	671.32	560	1020			
GD270-630-4-Ln(-EU)	737.14	630	1120			
GD270-710-4-Ln(-EU)	829.28	710	1260			
GD270-800-4-Ln(-EU)	960.91	800	1460			

Note: n = 1 or 3

Appendix G Further information

G.1 Product and service queries

If you have any queries about the product, contact the local INVT office. Please provide the model and serial number of the product you query about. You can visit www.invt.com to find a list of INVT offices.

G.2 Feedback on INVT VFD manuals

Your comments on our manuals are welcome. Visit www.invt.com, directly contact online service personnel or choose **Contact Us** to obtain contact information.

G.3 Documents on the Internet

You can find manuals and other product documents in the PDF format on the Internet. Visit www.invt.com and choose **Support > Download**.



E-mail: overseas@invt.com.cn Website: www.invt.com

The products are owned by **Shenzhen INVT Electric Co.,Ltd.**

Two companies are commissioned to manufacture: (For product code, refer to the 2nd/3rd place of S/N on the name plate.)

Shenzhen INVT Electric Co., Ltd. (origin code: 01)

Address: INVT Guangming Technology Building, Songbai Road,
Matian, Guangming District, Shenzhen, China

INVT Power Electronics (Suzhou) Co., Ltd. (origin code: 06)

Address: No.1 Kunlunshan Road, Science & Technology Town,
Suzhou New District, Jiangsu, China

- Industrial Automation:** ■ HMI ■ PLC ■ VFD ■ Servo System
 ■ Elevator Intelligent Control System ■ Rail Transit Traction System
- Energy & Power:** ■ UPS ■ DCIM ■ Solar Inverter ■ SVG
 ■ New Energy Vehicle Powertrain System ■ New Energy Vehicle Charging System
 ■ New Energy Vehicle Motor



Copyright© INVT.

Manual information may be subject to change without prior notice.

202507 (V1.4)