



DA200A Series AC Servo Drive User Manual



SHENZHEN INVT ELECTRIC CO., LTD.

Preface

Overview

Thank you for purchasing INVT DA200A series AC servo drive. If not otherwise specified, the drive mentioned in this manual refers to DA200A series AC servo drive.

The drive adopts modular design with abundant functions and powerful performance. The host controller software uses USB communication and the bus control is optional among Modbus bus, CANopen bus, EtherCAT bus and PN bus. Meanwhile, this product is equipped with online/offline inertia identification, gain switching, auto/manual notch filter, auto/manual vibration control filter, internal point-to-point (PTP) control, fully-closed loop control, function safety STO, specific functions of linear motors and 12-bit analog input, and supports multiple types of encoders. The drive adopts electromagnetic compatibility design to ensure strong anti-electromagnetic interference capacity while realizing low noise and weakening electromagnetic interference in the application sites.

This manual mainly instructs you how to install, wire, set parameters for, diagnose and remove faults for, and maintain the drive, and also lists related precautions. Read the manual carefully before installing and operating the drive.

Readers

Personnel with electrical professional knowledge (such as qualified electrical engineers or personnel with equivalent knowledge).

Change history

The manual is subject to change irregularly without prior notice due to product version upgrades or other reasons.

No.	Change description	Version	Release date
1	First release.	V1.0	June 2024

Contents

Preface	i
Overview.....	i
Readers.....	i
Change history	i
Contents	i
1 Safety precautions	1
1.1 Safety declaration.....	1
1.2 Safety definition	1
1.3 Personnel requirements.....	1
1.4 Safety guidelines	2
2 Product overview	5
2.1 Product overview.....	5
2.1.1 Product model and nameplate.....	5
2.1.2 Product component.....	8
2.1.3 Product dimensions and weight.....	9
2.2 Product specifications.....	9
2.2.1 Basic specifications.....	9
2.2.2 Electrical specifications	13
2.2.3 Communication specifications.....	16
3 Mechanical installation	18
3.1 Unpacking inspection.....	18
3.2 Preparing.....	18
3.2.1 Installation environment and site	18
3.2.2 Installation space	20
3.3 Installation methods	21
4 Electrical installation	22
4.1 Safety tips	22
4.2 Cable selection.....	22
4.2.1 Power cable.....	22
4.2.2 Control cable.....	23
4.3 System configuration	24
4.4 Main circuit wiring	26
4.4.1 Main circuit wiring diagrams	26
4.4.2 Main circuit terminals	29
4.5 Control circuit I/O terminal wiring (CN1).....	29
4.5.1 Pins of CN1 terminal.....	29
4.5.2 CN1 terminal signal.....	30

4.5.3 CN1 wiring instruction	47
4.6 Wring with the motor.....	56
4.6.1 Wiring for 220V 400W–1kW models using 40/60/80-base motor.....	57
4.6.2 Wiring for 220V 2kW–3kW and 380V 1.5kW–7.5kW models using 100/130/180-base motor.....	57
4.7 Wiring with the encoder	58
4.7.1 Wiring for models using 40/60/80-base absolute encoder motor.....	58
4.7.2 Wiring for models using 100/130/180-base absolute encoder motor.....	59
4.8 Function	60
4.8.1 Encoder terminal (CN2)	60
4.8.2 RS485/CAN terminal(CN3)	60
4.8.3 USB terminal (CN4)	61
4.8.4 Second encoder (CN5)	61
4.8.5 STO safety function introduction	62
4.8.6 Motor brake terminal (CN8).....	66
5 Control mode	67
5.1 Position control mode.....	67
5.2 Speed control mode	68
5.3 Torque control mode.....	69
5.4 Bus control mode	70
6 Commissioning tools	71
6.1 Keypad	71
6.1.1 Panel display	71
6.1.2 Common monitoring mode	73
6.1.3 Monitoring mode.....	74
6.1.4 Parameter setting mode instruction.....	74
6.1.5 Auxiliary function instruction	75
6.1.6 Fault mode	79
6.2 PC host controller software.....	80
6.2.1 Introduction of host controller software INVT Workshop	80
6.2.2 Installation requirements	80
6.2.3 Installation and running	81
6.2.4 Common functions.....	88
7 Commissioning and running.....	91
7.1 Commissioning flowchart	91
7.2 Connect to the power	91
7.3 Jogging.....	92
7.4 Running in position control mode	93
7.5 Running at the speed control mode	94
7.6 Running at the torque control mode	94

7.7 Adjustment.....	95
7.7.1 Inertia identification	95
7.7.2 Gain adjustment.....	97
7.7.3 Gain adjustment of position mode.....	100
7.7.4 Gain adjustment of speed mode	101
7.7.5 Gain adjustment of torque mode	103
7.8 Mechanical resonance suppressing	103
7.9 Gain switchover	105
7.10 Servo enabling.....	108
7.11 Servo stop/Stop running.....	108
7.12 Timing diagram.....	110
7.12.1 Sequence diagram of power-on and servo ON	110
7.12.2 Sequence diagram of power loss during running.....	111
7.12.3 Servo OFF sequence in a locked state.....	112
7.12.4 Servo OFF sequence in running state.....	113
7.12.5 Sequence of fault alarm.....	114
8 Communication.....	115
8.1 Communication introduction	115
8.2 Communication wiring	116
8.3 RS485 communication protocol	117
8.3.1 Protocol instruction	117
8.3.2 Communication frame structure.....	117
8.3.3 Command code and communication data description	118
8.3.4 Communication frame error check methods.....	120
8.3.5 Error message response	121
8.4 CANopen communication protocol	122
8.4.1 CANopen protocol description	122
8.4.2 CANopen hardware configuration.....	122
8.4.3 CANopen software configuration	123
8.4.4 CANopen functions	123
9 Function description.....	129
9.1 Basic control (Group P0 parameters)	129
9.1.1 Basic settings.....	129
9.1.2 Position control.....	139
9.1.3 Speed/Torque control.....	146
9.1.4 Control mode switchover	161
9.1.5 Speed display filtering	162
9.2 Autotuning control (Group P1 parameters).....	163
9.2.1 Inertia identification (Automatic gain).....	163
9.2.2 Self-adaptive vibration control	166

9.3 Motor control parameters (Group P2 parameters)	173
9.3.1 Gain setting	173
9.3.2 Gain switchover	177
9.3.3 Special motor control	183
9.4 I/O management parameters (Group P3 parameters)	194
9.4.1 Digital input/output configuration	194
9.4.2 Analog input/output adjustment	201
9.4.3 Digital input/output settings	209
9.4.4 Analog input 3 adjustment	215
9.5 Extension and application (Group P4 parameters)	218
9.5.1 Communication settings	218
9.5.2 Servo types and communication control commands	222
9.5.3 Extension and application	229
9.5.4 Special commands	237
9.5.5 Frequency-division output and second encoder settings	240
9.6 Program jog, homing, and PTP control (Group P5 parameters)	247
9.6.1 Program jog	247
9.6.2 Homing	250
9.6.3 PTP control	254
9.7 Application functions (Group P6 parameters)	272
9.8 PTP control (Group PtP0, PtP1 and PtP2 parameters)	292
9.9 State monitoring	341
9.9.1 User monitoring (Group R0 parameters)	341
9.9.2 I/O monitoring (Group R1 parameters)	359
9.9.3 Fault recording (Group R3 parameters)	364
10 Fault handling	367
10.1 Fault codes	367
10.2 Drive faults and solutions	372
10.3 CANopen communication faults and solutions	389
10.4 EtherCAT communication faults and solutions	391
10.5 PROFINET communication faults and solutions	392
10.6 PROFIDrive communication faults and solutions	393
11 Inspection and maintenance	394
Appendix A Parameter list	396
A.1 Setup parameter list	396
A.1.1 Function parameter list	396
A.1.2 State monitoring parameter list	442
A.2 Common monitoring parameters	446
A.3 Record table of parameter setting	448

1 Safety precautions





1.1 Safety declaration

Read this manual carefully and follow all safety precautions before moving, installing, wiring, operating and servicing the drive. Otherwise, equipment damage or physical injury or death may be caused.

We shall not be liable or responsible for any physical injury or equipment damage caused due to failure to follow the safety precautions.

1.2 Safety definition





To ensure personal safety and avoid property damage, you must pay attention to the warning symbols and tips in the manual.

Warning symbols	Name	Description
	Danger	Severe personal injury or even death can result if related requirements are not followed.
	Electric shock	Severe personal injury or even death can result if related requirements are not followed. As high voltage still presents in the bus capacitor after power off, wait for at least 15 minutes after power off to prevent electric shock.
	Warning	Personal injury or equipment damage can result if related requirements are not followed.
	Electrostatic discharge	The PCBA may be damaged if related requirements are not followed.
	Hot sides	You may get burnt if related requirements are not followed.
Note	Note	Slight personal injury or equipment damage can result if related requirements are not followed.

1.3 Personnel requirements



Trained and qualified professionals: People operating the equipment must have received professional electrical and safety training, and must be familiar with all steps and requirements of equipment installing, commissioning, running and maintaining and capable to prevent any emergencies according to experiences.





1.4 Safety guidelines

General principles	
	<ul style="list-style-type: none"> Only trained and qualified professionals are allowed to carry out related operations. Do not perform wiring, inspection or component replacement when power supply is applied. Before performing these operations, ensure all the input power supplies have been disconnected, and wait for at least the time designated on the drive.
	<ul style="list-style-type: none"> Do not modify the drive unless authorized; otherwise fire, electric shock or other injury may result. Prevent the screws, cables and other conductive parts from falling into the drive.
	<ul style="list-style-type: none"> The base may become hot when the drive is running. Do not touch. Otherwise, you may get burnt.
	<ul style="list-style-type: none"> The electrical parts and components inside the drive are electrostatic sensitive. Take measurements to prevent electrostatic discharge when performing related operations.

Delivery	
	<ul style="list-style-type: none"> Select appropriate tools for drive delivery to avoid damage to the drive, and take protective measures like wearing safety shoes and working uniforms to avoid physical injury or death. Protect the drive against physical shock or vibration. Do not carry the drive only by its front cover as the cover may fall off.

Installation	
	<ul style="list-style-type: none"> Do not install the drive on inflammables. In addition, prevent the drive from contacting or adhering to inflammables. Do not install the damaged or incomplete drive. Do not contact the drive with damp objects or body parts. Otherwise, electric shock may result. Do not connect the input power cables to the output terminals, otherwise damage to the drive may occur. Do not touch the conductive parts directly; do not connect any external cables (especially those related to electricity) to the enclosure or short connect the external cables, otherwise electric shock or short circuit may occur.





Wiring	
	<ul style="list-style-type: none"> • The installation site must be away from children and other public places. • Connect the optional braking parts (such as braking resistors and braking units). • Do ground with proper techniques and ensure the grounding resistor is less than 10Ω. The conductivity of PE earth conductor is the same as the phase conductor (with the same cross area). • L1, L2, and L3 are the power input terminals, while U, V, and W are the motor output terminals. Connect the input power cables and motor cables properly; otherwise, the drive may be damaged. • When the drive is installed in a confined space (such as cabinet), it is necessary to provide protective devices (such as fireproof housing, electrical protective housing, mechanical protective housing, etc.) that meet the IP rating, and the IP rating shall comply with the relevant IEC standards and local regulations. • Do install the overcurrent protector, leakage current protector and emergency device and ensure the normal usage after wiring, otherwise electric shock, hurt and fire may occur. • Connect the drive and motor as correct phase sequence, otherwise drive fault or damage may occur.
Commissioning	
	<ul style="list-style-type: none"> • Do not switch on or switch off the input power supplies of the drive frequently. • If the drive has been stored for a long time without being used, perform checking and carry out pilot run for the drive before using it again. • Set the corresponding parameters before operation, otherwise the drive may run abnormally or beyond the expectation because of the load.
Running	
	<ul style="list-style-type: none"> • Close the drive front cover before running; otherwise, electric shock may occur. • De-couple the motor load and run the motor independently before operation to avoid accidents. • Check whether the AC power supply is the same as the rated voltage of the servo drive, otherwise fire, hurt, damage to the drive may occur. • Please ensure the drive can be disconnected from the power supply by E-switch before any operation.

Maintenance	
	<ul style="list-style-type: none"> Do not perform drive maintenance or component replacement when the power is on. Otherwise, electric shock may result. Keep the drive and its parts and components away from combustible materials and ensure they have no combustible materials adhered.
	<ul style="list-style-type: none"> During maintenance and component replacement, take proper anti-static measures on the drive and its internal parts.
	<ul style="list-style-type: none"> Do not carry out any insulation and voltage withstand test to the drive directly, and do not test the control circuit of the drive by megameter.
Note	<ul style="list-style-type: none"> Use proper torque to tighten screws.
Disposal	
	<ul style="list-style-type: none"> The components inside the drive contain heavy metals. Dispose of a scrap drive as industrial waste.

2 Product overview

2.1 Product overview

2.1.1 Product model and nameplate

-  Read manual carefully and follow the directions.
务必在阅读使用说明书后，按其步骤操作！
-  Disconnect all power and wait 15 min before servicing. May cause electric shock.
通电中或断电15分钟内，请勿触摸端子，有触电危险！
-  Don't touch heatsink. May cause burn.
请勿触摸散热片，有烫伤危险！
-  Contact currents up to 15mA. Before use, must be reliable grounding.
接触电流可达到15mA，使用前必须可靠接地！

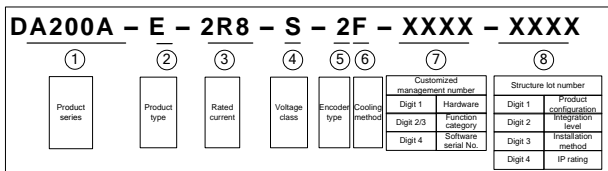
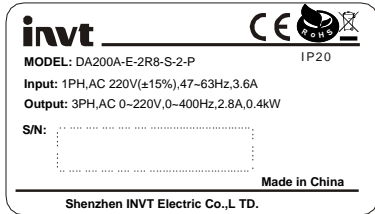
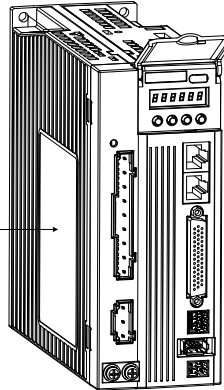

Symbol	Description	Definition
①	Product series	DA: AC servo drive DL: Low-voltage AC servo drive SL: Loom servo drive MH: Electro-hydraulic servo drive 200A: Product series (expressed by a number with no more than three digits) When the number of digits are different, the more the number of digits, the higher the product positioning/functionality level; When the number of digits are same, the larger the digit, the higher the product positioning/functionality level.

Symbol	Description	Definition		
		First digit of the product series 1: Basic product 2: High-performance type product 3: Intelligent product 6: Multi-drive product 8: Electro-hydraulic servo product	Second digit of the product series *0: General purpose *6: Special for machine tool industry: woodworking machine tools, hydraulic machine tools, etc. *7: Full-function product platform *8: Specialized platform for small power ($\leq 2\text{kW}$) Others are reserved.	Third digit of the product series is 0 by default.
**A: Product series version: First version				
②	Product type	Product type: E: Pulse type S: Standard type (pulse, 16-bit analog, CAN) C: CANopen bus type P: PROFIBUS-DP bus type F: PROFINET N: EtherCAT bus type M: Mechatrolink 3 bus type		
③	Rated current (A)	2R8: 2.8A		
④	Voltage class	AC is identified with a single letter: S: 1PH /3PH 220V T: 3PH 380V DC is identified with two digits: 36: 36V 48: 48V		
⑤	Encoder type	0: Supporting quadrature pulse encoder and Tamagawa protocol communication encoder 1: Quadrature pulse encoder 2: Tamagawa protocol communication encoder 7: Rotary transformer		
⑥	Cooling method	N: Natural cooling (omitted by default) F: Forced air cooling (omitted for general-purpose servo 7.5kW and lower models by default) Y: Liquid cooling		

Symbol	Description	Definition
⑦	Customized management number (omitted for standard models by default)	Hardware (digit 1): 0-9 and A-Z Function category (digit 2/3): 0-9 and A-Z Software serial No. (digit 4): 0-9 and A-Z
⑧	Structure lot number	Product configuration: Omitted by default: Standard version E: Simple-spec version P: High-spec version Z: Direct-drive /linear Integration level (number of axes): 1: Single axis (omitted by default) 2: Two-in-one 3: Three-in-one Installation method: B: Substrate installation (standard), omitted by default C: Backpack-type installation F: Flange mounting Ingress protection (IP) rating: Omitted by default: IP20 0: IP00 2: IP23 5: IP54 6: IP65

Function difference between different machine types:

Power range: 400W-7.5kW			Function						Communication				
Drive type	Symbol	Configuration selection	Pulse input	Analog input/output	2nd encoder	STO	Brake output	Dynamic braking	RS485	CANopen	EtherCAT	PROFINET	PROFINET drive
Pulse type	E	Standard	✓	✓	-	-	-	✓	✓	-	-	-	-
		High-spec	✓	✓	✓	✓	✓	✓	✓	-	-	-	-
Bus type	N	Standard	-	-	-	-	-	✓	-	-	✓	-	-
		High-spec	-	-	✓	✓	✓	✓	-	-	✓	-	-
	C	High-spec	✓	✓	✓	✓	✓	✓	✓	✓	-	-	-
	F	High-spec	-	-	✓	✓	✓	✓	-	-	-	✓	-

Note: In the table, “✓” indicates that this function is available, “-” indicates that this function is unavailable.

2.1.2 Product component

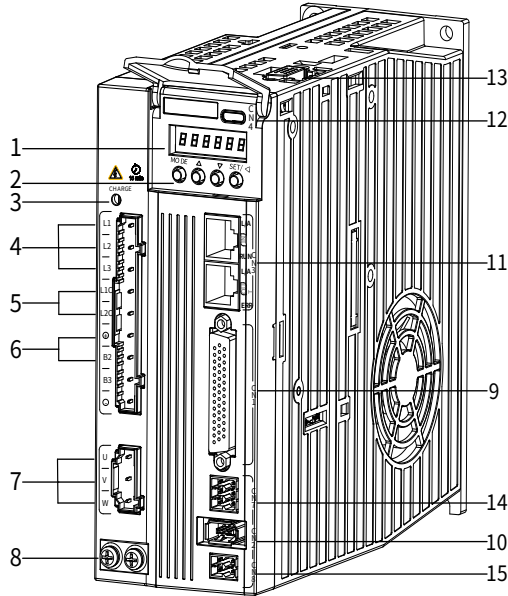

No.	Component	Description
1	LED display	Digital tube display
2	Operation panel	Menu key
3	CHARGE indicator	Main circuit power-on display
4	Main circuit power	Power input
5	Control circuit power	Control power input
6	Regenerative resistor	External braking resistor
7	Motor	Motor power terminal
8	Grounding	PE safe grounding
9	CN1 interface	I/O control input/output signal
10	CN2 interface	First encoder
11	CN3 interface	CAN/RS485 communication port
12	CN4 interface	Upper PC USB communication port
13	CN5 interface	Second encoder
14	CN7 interface	STO port
15	CN8 interface	Motor brake port

2.1.3 Product dimensions and weight

Figure 2-1 Product dimensions

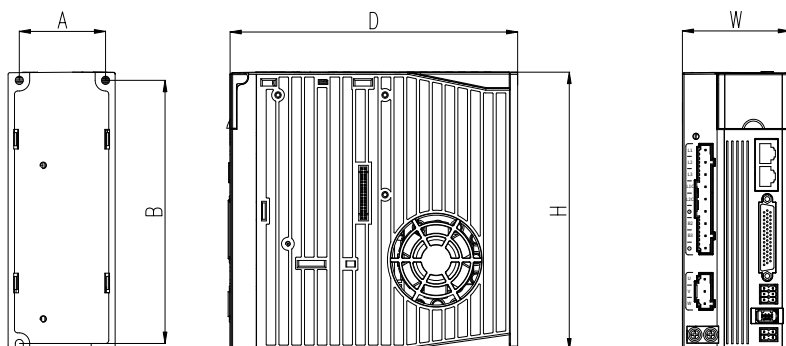

Table 2-1 Product dimensions and weight

Volume	Outline dimensions (mm)			Installation dimensions (mm)		Mounting hole diameter (mm)	Net weight (kg)
	H	W	D	A	B		
A	170	45	170	33	162	∅5(M4)	1.03
B	170	67	180	54	162	∅5(M4)	1.45
C	170	84	180	71	162	∅5(M4)	1.75
D	245	92	190	79	237	∅5(M4)	2.97

2.2 Product specifications

2.2.1 Basic specifications

DA200A series servo drive			
Specification		Description	
Power supply	System input voltage of 220V		1PH/3PH AC200V(-15%)~240V(+10%) 47Hz~63Hz
	System input voltage of 400V		3PH AC380V(-15%)~480V(+10%) 47Hz~63Hz
Port	Control signal	Input	10 inputs for standard type, 7 inputs for bus type servo (the function can be configured by relevant parameters). Input range: 12~24V; Input bandwidth: More than 1k. Switching delay: Less than 5μs

DA200A series servo drive			
Specification			Description
		Output	4 differential outputs for standard type and EtherCAT bus type (the function can be configured by relevant parameters). Output range: 12–24V; Output bandwidth: More than 1k.
	Analog	Input	2 12-bit inputs, input range: -10V+10V.
		Output	2 outputs (analog monitoring output), output range: -10V+10V, 12-bit resolution.
	Pulse signal	Input	2 differential inputs, Puls+Sign. Indicator: Differential input 4Mbps, open collector input 200kbps. (High-speed optocoupler with high signal-noise rejection ratio)
		Output	Six outputs (3 differential outputs, 3 open collector outputs)
	First encoder	Input	Two-wire and four-wire absolute encoder interfaces (Tamagawa, Nikon, BISS and EnDat2.2). Indicator: Max. baud rate of absolute encoder 5Mbps
	Second encoder	Input	Incremental encoder (Second encoder or fully-closed loop linear encoder), indicator: Max. quadrature input frequency 12Mbps, supporting ABZ disconnection detection function
	Communication	USB	1:1 communication upper PC software (standard, Type-C)
		RS485	1:n communication (standard)
		CANopen	1:n communication (optional)
		PROFIdrive	1:n communication (optional)
		EtherCAT	1:n communication (optional)
	Safety terminals	STO	Safe torque off (conform to the latest European safety standards SIL3) (optional)
Control mode			1. Position control; 2. Speed control; 3. Torque control; 4. Position/Speed mode switching; 5. Speed/Torque mode switching; 6. Position/Torque mode switching; 7. Fully-closed loop control; 8. CANopen mode; 9. EtherCAT mode
Function	Position control	Control input	1. Clear residual pulses 2. Disable command pulse input

DA200A series servo drive					
Specification		Description			
			3. Electronic gear ratio switching 4. Vibration control switching		
		Control output	Positioning completion output, etc		
		Pulse input	Max. pulse input frequency	Optical coupling: differential input 4Mpps, open collector input 200kpps;	
			Pulse input mode	1. Pulse + direction; 2. CW+CCW; 3. Quadrature	
			Electronic gear	1/10000-1000 times	
			Filter	1. Command smoothing filter; 2. FIR filter	
		Analog input	Torque limit command input	Can independently perform clockwise/counterclockwise torque limit	
		Vibration control	Able to suppress 5-200Hz front-end vibration and overall machine vibration		
		Pulse output	1. Can perform arbitrary frequency division settings under the encoder resolution; 2. B phase reverse function		
	Speed control	Control input	1. Internal command speed 1; 2. Internal command speed 2; 3. Internal command speed 3; 4. Zero speed clamp, etc		
		Control output	Speed reaching, etc		
		Analog input	Speed command input	The speed command input can be set according to the analog voltage DC ± 10V	
			Torque limit input	Can independently perform clockwise/counterclockwise torque limit	
		Internal speed	8 step speed can be switched according to the external control input		

DA200A series servo drive				
Specification		Description		
		commands		
		ACC/DEC adjustment of speed command	ACC/DEC time setting and S curve setting	
		Zero-speed clamp	In the speed mode, it can set the operation mode as the speed mode and position mode	
		Speed command filter	A delay filter of analog input speed command	
		Speed command zero drift control	Zero drift control against outside interference with 0.3mV precision	
Torque control	Control input	Zero speed clamp input, etc		
	Control output	Speed reaching, etc		
	Analog input	Torque command input	Analog torque command input, gain and polarity can be set based on analog voltage with 4.88mV precision	
		Speed limit input	Analog speed limit	
	Speed limit	Set the speed limit by parameters		
	Torque command filter	A delay filter of analog input torque command		
	Torque command zero drift control	Zero drift control against outside interference with 4.88mV precision		
Internal position plan	Plan bits	128 bits internal position planning, the positioning can be controlled through communication		
	Route setting	1. Position 2. Speed 3. ACC time 4. DEC time 5. Stop timer		

DA200A series servo drive		
Specification		Description
	Homing	6. Various state output 7. Running mode
		1. LS signal 2. Z phase signal 3. LS signal+Z phase signal 4. Torque limit signal
Protection	Hardware protection	Protection against overvoltage, undervoltage, overcurrent, overspeed, overload, braking resistor overload, drive overheat, encoder fault and so on
	Software protection	Protection against storage fault, initialization fault, I/O distribution abnormalities and large position deviation
	Protection and fault record	1. Up to 10 faults can be recorded. 2. The key parameters can be recorded when fault occurs.
Environment	Working temperature	0–55 °C (Derate 80% when the ambient temperature is 45–55 °C.)
	Storage temperature	-20 °C–70 °C (No freezing)
	Operation/storage humidity	RH≤ 90% (no condensation)
	IP class	IP20 (except power terminals and power cable terminals (IP00))
	Altitude	Lower than 1000m
	Vibration	<0.5G(4.9m/S ²), 10–60Hz (Working at the resonance point is not allowed)

2.2.2 Electrical specifications

Cabinet volume	Model	Input		Output	
		Voltage (V)	Rated current (A)	Power (kW)	Rated current (A)
A	DA200A-E-1R6-T-2	3PH 380	0.87	0.4	1.6
	DA200A-E-1R6-T-2-P	3PH 380	0.87	0.4	1.6
	DA200A-N-1R6-T-2	3PH 380	0.87	0.4	1.6
	DA200A-N-1R6-T-2-P	3PH 380	0.87	0.4	1.6
	DA200A-C-1R6-T-2-P	3PH 380	0.87	0.4	1.6
	DA200A-F-1R6-T-2-P	3PH 380	0.87	0.4	1.6
	DA200A-E-2R8-S-2	1PH 220	3.6	0.4	2.8

Cabinet volume	Model	Input		Output	
		Voltage (V)	Rated current (A)	Power (kW)	Rated current (A)
	DA200A-E-2R8-S-2-P	1PH 220	3.6	0.4	2.8
	DA200A-N-2R8-S-2	1PH 220	3.6	0.4	2.8
	DA200A-N-2R8-S-2-P	1PH 220	3.6	0.4	2.8
	DA200A-C-2R8-S-2-P	1PH 220	3.6	0.4	2.8
	DA200A-F-2R8-S-2-P	1PH 220	3.6	0.4	2.8
	DA200A-E-6R0-S-2	1PH 220	9.0	1.0	6.0
	DA200A-E-6R0-S-2-P	1PH 220	9.0	1.0	6.0
	DA200A-N-6R0-S-2	1PH 220	9.0	1.0	6.0
	DA200A-N-6R0-S-2-P	1PH 220	9.0	1.0	6.0
	DA200A-C-6R0-S-2-P	1PH 220	9.0	1.0	6.0
	DA200A-F-6R0-S-2-P	1PH 220	9.0	1.0	6.0
B	DA200A-E-8R0-S-2	1PH/3PH 220	13.5/5.6	1.5	8.0
	DA200A-E-8R0-S-2-P	1PH/3PH 220	13.5/5.6	1.5	8.0
	DA200A-N-8R0-S-2	1PH/3PH 220	13.5/5.6	1.5	8.0
	DA200A-N-8R0-S-2-P	1PH/3PH 220	13.5/5.6	1.5	8.0
	DA200A-C-8R0-S-2-P	1PH/3PH 220	13.5/5.6	1.5	8.0
	DA200A-F-8R0-S-2-P	1PH/3PH 220	13.5/5.6	1.5	8.0
	DA200A-E-010-S-2	1PH/3PH 220	18.1/7.5	2.0	10
	DA200A-E-010-S-2-P	1PH/3PH 220	18.1/7.5	2.0	10
	DA200A-N-010-S-2	1PH/3PH 220	18.1/7.5	2.0	10
	DA200A-N-010-2-S-P	1PH/3PH 220	18.1/7.5	2.0	10
	DA200A-C-010-S-2-P	1PH/3PH 220	18.1/7.5	2.0	10
	DA200A-F-010-S-2-P	1PH/3PH 220	18.1/7.5	2.0	10
	DA200A-E-5R5-T-2	3PH 380	3.3	1.5	5.5

Cabinet volume	Model	Input		Output	
		Voltage (V)	Rated current (A)	Power (kW)	Rated current (A)
	DA200A-E-5R5-T-2-P	3PH 380	3.3	1.5	5.5
	DA200A-N-5R5-T-2	3PH 380	3.3	1.5	5.5
	DA200A-N-5R5-T-2-P	3PH 380	3.3	1.5	5.5
	DA200A-C-5R5-T-2-P	3PH 380	3.3	1.5	5.5
	DA200A-F-5R5-T-2-P	3PH 380	3.3	1.5	5.5
C	DA200A-E-013-S-2	1PH/3PH 220	27.3/11.2	3.0	13
	DA200A-E-013-S-2-P	1PH/3PH 220	27.3/11.2	3.0	13
	DA200A-N-013-S-2	1PH/3PH 220	27.3/11.2	3.0	13
	DA200A-N-013-S-2-P	1PH/3PH 220	27.3/11.2	3.0	13
	DA200A-C-013-S-2-P	1PH/3PH 220	27.3/11.2	3.0	13
	DA200A-F-013-S-2-P	1PH/3PH 220	27.3/11.2	3.0	13
	DA200A-E-8R5-T-2	3PH 380	6.5	3.0	8.5
	DA200A-E-8R5-T-2-P	3PH 380	6.5	3.0	8.5
	DA200A-N-8R5-T-2	3PH 380	6.5	3.0	8.5
	DA200A-N-8R5-T-2-P	3PH 380	6.5	3.0	8.5
	DA200A-C-8R5-T-2-P	3PH 380	6.5	3.0	8.5
	DA200A-F-8R5-T-2-P	3PH 380	6.5	3.0	8.5
D	DA200A-E-012-T-2	3PH 380	9.6	4.4	12
	DA200A-E-012-T-2-P	3PH 380	9.6	4.4	12
	DA200A-N-012-T-2	3PH 380	9.6	4.4	12
	DA200A-N-012-T-2-P	3PH 380	9.6	4.4	12
	DA200A-C-012-T-2-P	3PH 380	9.6	4.4	12
	DA200A-F-012-T-2-P	3PH 380	9.6	4.4	12
	DA200A-E-016-T-2	3PH 380	11.9	5.5	16
	DA200A-E-016-T-2-P	3PH 380	11.9	5.5	16
	DA200A-N-016-T-2	3PH 380	11.9	5.5	16
	DA200A-N-016-T-2-P	3PH 380	11.9	5.5	16
	DA200A-C-016-T-2-P	3PH 380	11.9	5.5	16
	DA200A-F-016-T-2-P	3PH 380	11.9	5.5	16

Cabinet volume	Model	Input		Output	
		Voltage (V)	Rated current (A)	Power (kW)	Rated current (A)
	DA200A-E-021-T-2	3PH 380	16.3	7.5	21
	DA200A-E-021-T-2-P	3PH 380	16.3	7.5	21
	DA200A-N-021-T-2	3PH 380	16.3	7.5	21
	DA200A-N-021-T-2-P	3PH 380	16.3	7.5	21
	DA200A-C-021-T-2-P	3PH 380	16.3	7.5	21
	DA200A-F-021-T-2-P	3PH 380	16.3	7.5	21

Note:

- You can set the carrier frequency to make current up to 25A for 7.5kW models.
- PN bus type is in development.

2.2.3 Communication specifications

Specification		Description	
Port	Communication	USB	1:1 communication upper PC software (standard)
		RS485	1:n communication (standard)
		CANopen	1:n communication (optional)
		PROFINET	1:n communication (optional)
		EtherCAT	1:n communication (optional)
Safety terminals	STO	Safe torque off (conform to the latest European safety standards SIL3) (optional)	
Basic performance of the slave	Supported services	PROFINET	DP-V0 protocol (F0/7 servo)
		PROFIdrive	Profidrive (D0/7 servo)
		EtherCAT	CoE (PDO, SDO)
	Synchronization method	PROFINET	RT, IRT
		EtherCAT	Distributed clocks (DCs)
	Transmission medium	PROFINET	Shielded category-6 or higher network cables
		EtherCAT	Shielded category-5 or higher network cables
	Number of slaves	PROFINET	Supports up to 256 slaves
		EtherCAT	Supports up to 65535 slaves, it is recommended to use less than 128 slaves in actual networking.
	Min. synchronization period	PROFINET	250µs
EtherCAT		125µs	
Physical layer		100BASE-TX	

Specification	Description
Baud rate	100 Mbit/s (100Base-TX)
Duplex method	Full duplex
Topology structure	Circular, linear
Transmission distance	Distance between two nodes is less than 100M (good environment and cables)
Synchronous jitter	<1 μ s
Control mode	<ol style="list-style-type: none"> 1. Position control 2. Speed control 3. Torque control 4. Position/Speed mode switching 5. Speed/Torque mode switching 6. Position/Torque mode switching 7. Fully-closed loop control I (only supported by the high-spec version) 8. CANopen mode 9. EtherCAT mode

 **Note:** The safety function is in the process of certification.

3 Mechanical installation

3.1 Unpacking inspection

After receiving the product, perform the following steps to ensure the product use safety.

- **Check the package**

Before unpacking, check whether the product package is intact—whether the package is damaged, dampened, soaked, or deformed. After unpacking, check whether the interior surface of the packing box is abnormal, for example, in wet condition.

- **Check the machine and parts**

After unpacking, check whether the equipment enclosure is damaged or cracked, whether the parts (including the drive and manual) inside the packing box are complete, and whether the nameplate and label on the product body are consistent with the model ordered.





3.2 Preparing

Only trained and qualified professionals are allowed to carry out the operations mentioned in this chapter. Read the following installation preparation carefully before installation to ensure smooth installation and avoid personal injury or equipment damage.



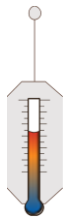

Alarm	
	<ul style="list-style-type: none"> ● Carry out operations according to instructions presented in chapter 1 Safety precautions. Ensure the drive power has been disconnected before installation. If the drive has been powered on, disconnect the drive and wait for at least the time designated on the drive, and ensure the POWER indicator is off. ● The drive installation must be designed and done according to applicable local laws and regulations. We do not assume any liability whatsoever for any equipment installation which breaches local laws or regulations.

3.2.1 Installation environment and site

- **Environment requirements**

Environment	Requirement	
Temperature		<ul style="list-style-type: none"> • 0–45°C • Do not use the drive when the ambient temperature exceeds 45°C. When the ambient temperature exceeds 45°C, derate 1% for every increase of 1°C. • The temperature does not change rapidly. • When the drive is installed in a closed space, such as control cabinet, use a cooling fan or air conditioner for temperature adjustment if necessary. • When the temperature is too low, if you want to use the drive that has been idled for a long time, install an external heating device before the use to eliminate the freeze inside the drive. Otherwise, the drive may be damaged.
Relative humidity (RH)		<ul style="list-style-type: none"> • The relative humidity (RH) of the air is less than 90%, and there is no condensation. • The max. RH cannot exceed 60% in the environment where there are corrosive gases.
Altitude		<ul style="list-style-type: none"> • Lower than 1000 meters • When the altitude exceeds 1000m, derate by 1% for every increase of 100m. • When the altitude exceeds 3000m, consult our local dealer or office for details.
Vibration		<ul style="list-style-type: none"> • Max. vibration ACC: <math>< 0.5G(4.9m/S^2)</math>

■ Site requirement

Site	Requirement	
Indoor		Without electromagnetic radiation sources and direct sunlight. Note: The drive must be installed in a clean and well-ventilated environment based on the housing IP rating.
		Without foreign objects such as oil mist, metal powder, conductive dust, and water.
		Without radioactive, corrosive, hazard, and combustible and explosive substances. Note: Do not install the drive onto combustible objects.
		With low salt content.

3.2.2 Installation space

Please install the servo drive vertically and keep enough installation space for good ventilation. Install fans if necessary to ensure the temperature inside the control cabinet is lower than 45°C.

3.2.2.1 Single drive

Figure 3-1 Installation space diagram of single drive

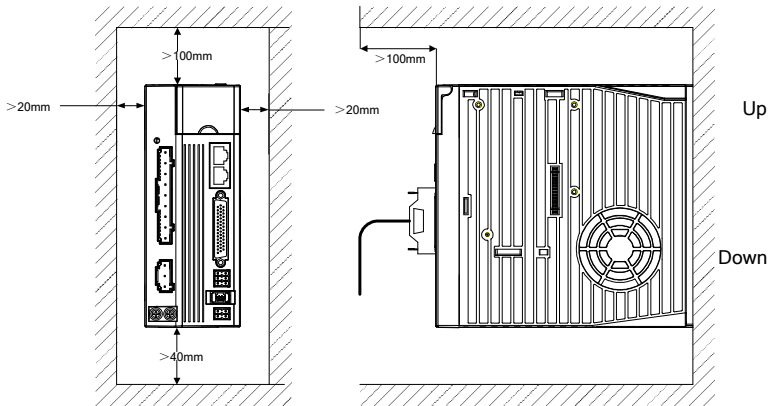

3.2.2.2 Multiple drives

Figure 3-2 Installation space diagram of multiple drives

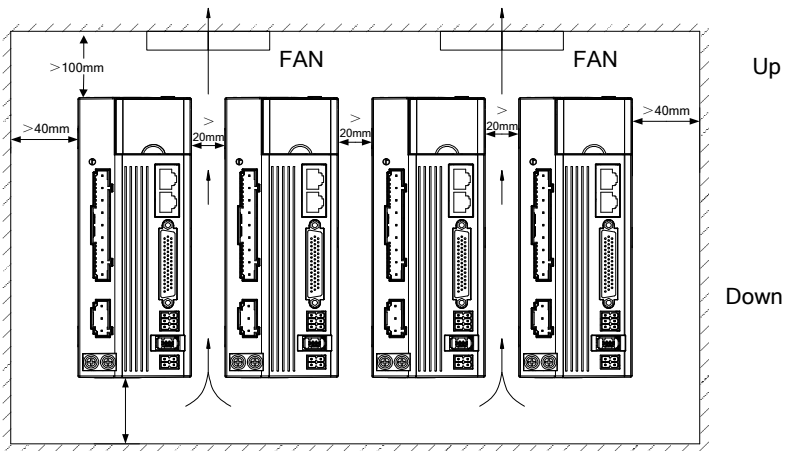

3.3 Installation methods

The servo drive only supports wall mounting.

The mounting procedures are as follows:

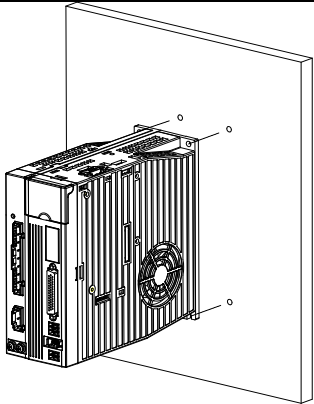
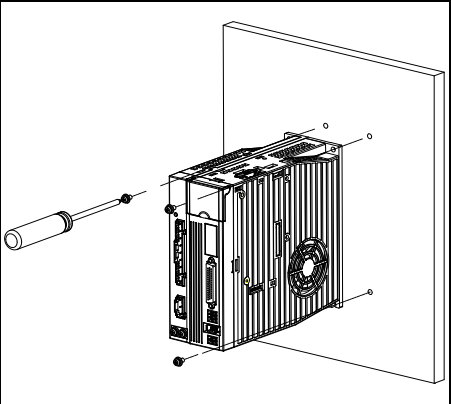
<p>Step1 Mark the mounting location according to the mounting holes on the drive.</p>	<p>Step2 Align the screws or bolts through the mounting holes with the mounting marks, and tighten the screws for fixing.</p>
	

4 Electrical installation

4.1 Safety tips

Read all safety precautions of this manual carefully. Otherwise, equipment damage or physical injury may be caused.

	Warning
<ul style="list-style-type: none">• Do not turn on the input power supply of the drive when the grid power is inconsistent with the input power specification indicated on the machine nameplate.• Connect the drive and motor as correct UVW phase sequence.• Only trained professionals are allowed to conduct wiring operations.• Do not connect the input power cables to the output terminals.• Do not carry out any insulation and voltage withstand test to the drive directly.• Do not test the control circuit of the drive by megameter.• Do not use the electromagnetic contactor to start or stop the servo drive.• Do not touch conductive parts directly.• Do not connect any external cables (especially those related to electricity) to the enclosure or short connect the external cables.• Wait for at least 15 minutes after disconnecting power before rewiring the drive.• Do ground with proper techniques because the touch current may be 0.5mA electric shock may occur.• The touch current may exceed 3.5mA during the drive running. Do ground with proper techniques and ensure the grounding resistor is less than 10Ω. The conductivity of PE earth conductor is the same as the phase conductor (with the same cross area).	

4.2 Cable selection

4.2.1 Power cable

Power cables mainly include input power cables and motor cables. Comply with local regulations to select power cables.

To meet the EMC requirements stipulated in the CE standards, it is recommended to use shielded four-core cables for input cables, as shown in [Figure 4-1](#).

Figure 4-1 Shielded four-core cables

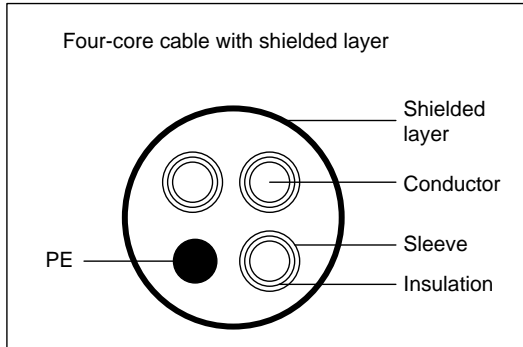
**Note:**

- The input power cables and motor cables must be able to carry the corresponding load currents.
- The temperature limit of the cable conductor current-carrying capacity is 70°C.
- When the shielded cable and phase conductor are of the same material, the cross-sectional area of the shielded cable must be the same as that of the phase conductor.
- To effectively restrict the emission and conduction of radio frequency (RF) interference, the conductivity of the shielded cable must be 1/10 of the conductivity of the phase conductor. The coverage rate of shielded layer must be above 85% at least.

4.2.2 Control cable

Control cables mainly include analog signal control cables and digital signal control cables. Analog signal control cables use twisted double shielded cables with a separate shielded twisted pair for each signal and different ground wires for different analog signals. For digital signal control cables, a double-shielded cable is preferred, and single-shielded or unshielded twisted pairs can also be used.

Note:



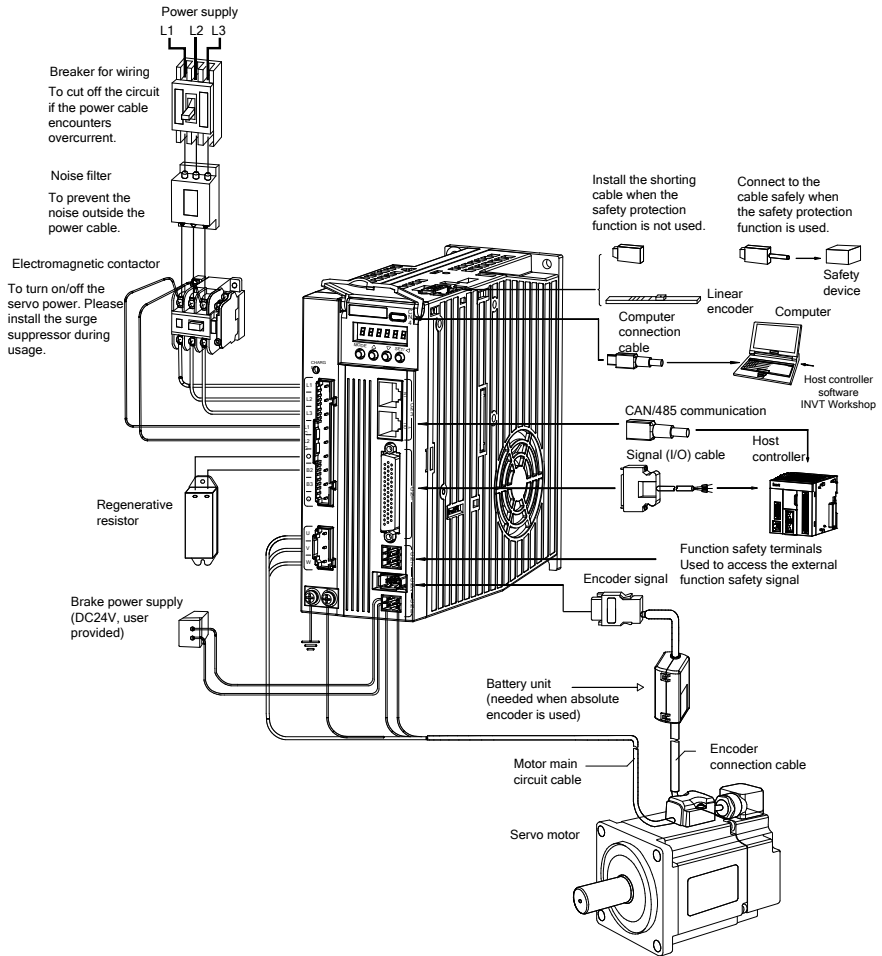

- It is recommended to use shielded cables for pulse input signal cables.
- A shielded twisted-pair cable must be used for a communication cable.

4.3 System configuration



Note:

- It is necessary to remove the short connection cable between B2 and B3 when connecting the external regenerative resistor.
- The external regenerative resistor must be installed on flame-resistance material which has good cooling effect, such as metal.

Component		Position	Description
	Breaker	Between the power supply and the drive input side	Cut off the circuit when an overcurrent flows through the power cable.
	Noise filter	Drive input side	Prevent noise from outside the power cable.
	Electromagnetic contactor	Drive input side	Turn on or turn off the servo power, and install a surge suppressor when using it.
	Regenerative resistor	Between the drive main circuit terminals (+) and B2	Accessories used to consume the regenerative energy of the motor to reduce the DEC time. Resistor: Optional external part for all models
	Host controller software	Installed in the host controller which controls the drive	INVT Workshop software is used to configure and monitor the drive. For details about main functions, refer to section 6.2.1 Introduction of host controller software INVT Workshop .

4.4 Main circuit wiring

4.4.1 Main circuit wiring diagrams

Figure 4-2 Main circuit wiring for 220V models in frame size A

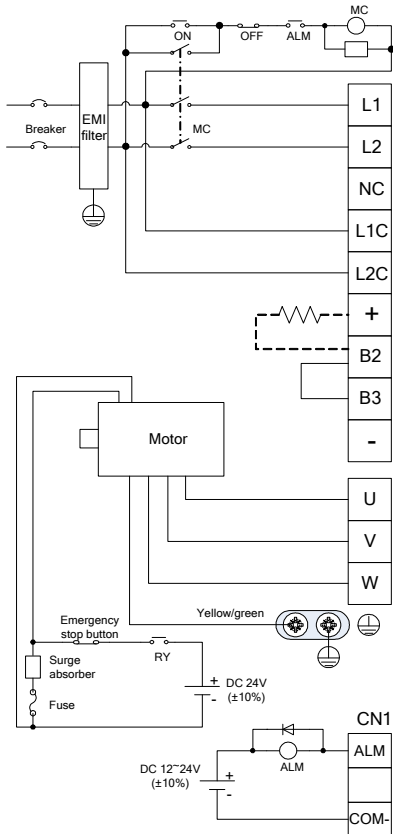

- You must make this emergency stop protection circuit. Add surge absorbing devices on both ends of the electromagnetic contactor winding.
- 220V system input voltage range: AC 220V(±15%)
For main circuit, connect to terminals L1 and L2.
- Note: Use the 3PH input power for 1.5kW or higher drive models.

Do not disconnect the short connection cable between B2 and B3, unless external regenerative brake resistor is used.
When external regenerative brake resistor is used, disconnect the short connection cable between B2 and B3 and make connection based on the dotted lines in the diagram.

- Connect output U, V and W to the drive according to the motor cable phase sequence of servo motor, wrong phase sequence will cause drive fault.

- Be sure to ground the servo drive to avoid accident of electrical shock.

- The electromagnetic brake uses 24V DC power supply which should
- be provided by the user. Moreover, it must be isolated from the DC12-24V power supply which is used by the control signal.
 - Pay attention to the connection of the freewheeling diode. Reversed polarity may damage the drive.
 - The low-spec version uses CN1 port for wiring while the high-spec version has a dedicated brake port for wiring and it can also use CN1 port for wiring.

Figure 4-3 Main circuit wiring for 380V models in frame size A and models in frame size B/C/D

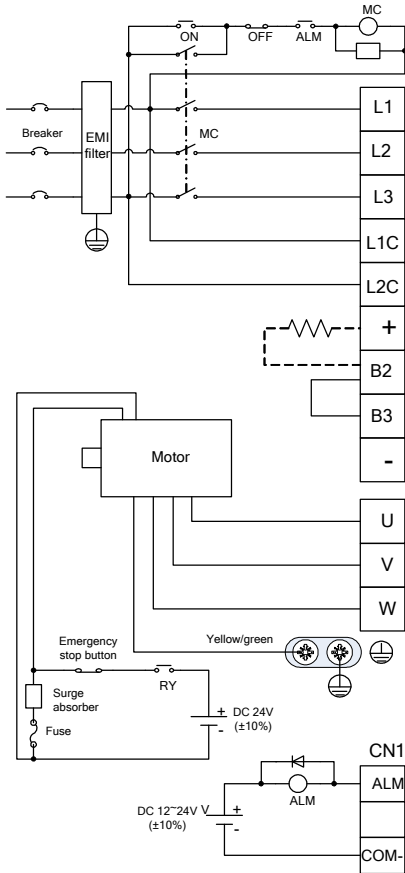

- You must make this emergency stop protection circuit. Add surge absorbing devices on both ends of the electromagnetic contactor winding.
- 220V system input voltage range: AC 220V(±15%), in which, 220V models of size B and C also support 1PH input for derating. For 1PH input wiring, refer to Figure 4-2.
- 440V system input voltage range: AC 380V(±15%)
- Do not disconnect the short connection cable between B2 and B3, unless external regenerative brake resistor is used. When external regenerative brake resistor is used, disconnect the short connection cable between B2 and B3 and make connection based on the dotted lines in the diagram.
- Connect output U, V and W to the drive according to the motor cable phase sequence of servo motor, wrong phase sequence will cause drive fault.
- Be sure to ground the servo drive to avoid accident of electrical shock.
- The electromagnetic brake uses 24V DC power supply which should be provided by the user. Moreover, it must be isolated from the DC12-24V power supply which is used by the control signal.
- Pay attention to the connection of the freewheeling diode. Reversed polarity may damage the drive.
- The low-spec version uses CN1 port for wiring while the high-spec version has a dedicated brake port for wiring and it can also use CN1 port for wiring.

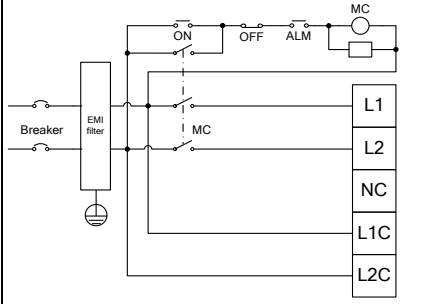
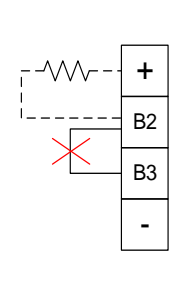
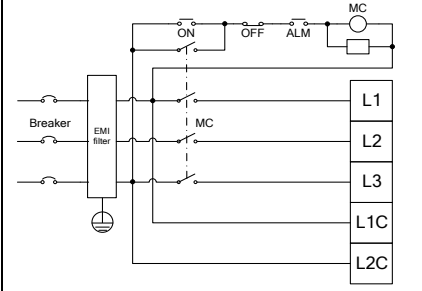
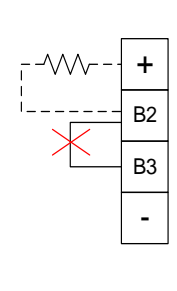
① Input power module	Input power	Power range	② External regenerative resistor
	<p>1PH AC 200V(-15%)– 240V(+10%)</p>	<p>220V 400W–1.0kW</p>	
	<p>3PH AC 200V(-15%)– 240V(+10%) 3PH AC 380V(-15%)– 480V(+10%)</p>	<p>220V 2.0kW– 3.0kW 400V 0.4kW– 7.5kW</p>	

Note:

- You must make the emergency stop protection circuit according to the schematic diagram of the input power module.
- For 1PH 220V main circuit, connect to terminals L1 and L2.
- It is necessary to add surge absorbing devices on both ends of the electromagnetic contactor.
- Connect output terminals U, V and W of the drive according to the phase sequence of servo motor.
- The electromagnetic brake uses 24V DC power supply which should be provided by you. Moreover, it must be isolated from the 12–24V DC power supply which is used by the control signal.

4.4.2 Main circuit terminals

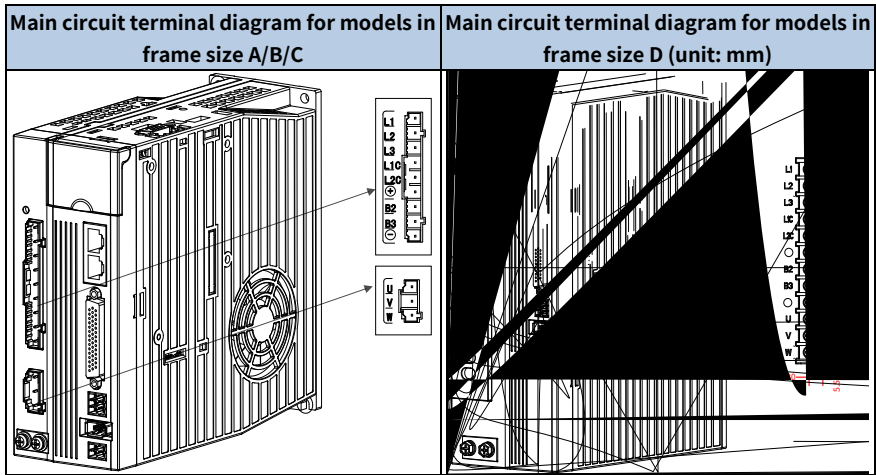

Terminal signal	Function description
L1, L2, L3	3PH/1PH AC input terminals, connected to the power grid
L1C, L2C	Control circuit power input terminals
U, V, W	3PH AC output terminals, connected to the motor usually
B2, B3	Built-in resistor
(+), B2	External resistor
(+), (-)	Bus positive and negative terminals can be paralleled to share the DC bus
	Grounding terminal for safe protection; each machine must carry two PE terminals and proper grounding is required.

4.5 Control circuit I/O terminal wiring (CN1)

4.5.1 Pins of CN1 terminal

Figure 4-4 Pulse-type and CANopen bus-type interface definition

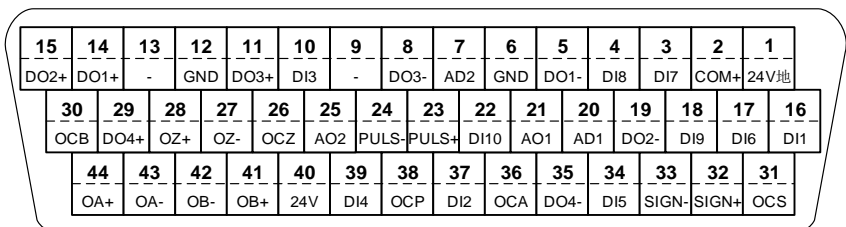
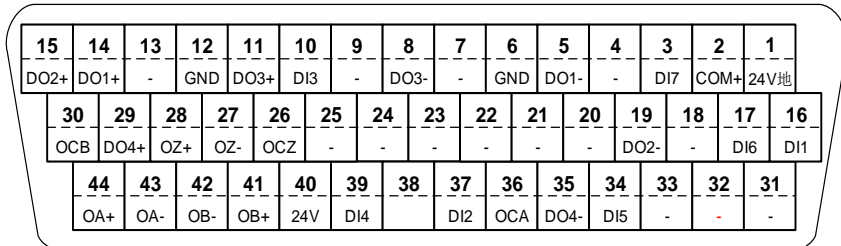

Figure 4-5 EtherCAT, PROFINET and PROFIdrive bus-type interface definition



4.5.2 CN1 terminal signal

Pin	Signal	Name	Pin	Signal	Name
1	24V ground	24V power ground	23	PULS+	Differential command pulse +
2	COM+	Common terminal of digital input	24	PULS-	Differential command pulse -
3	DI7	Digital input 7	25	AO2	Analog output 2
4	DI8	Digital input 8	26	OCZ	Z-phase open collector output
5	DO1-	Digital output 1 -	27	OZ-	Z-phase differential output -
6	GND	Signal ground	28	OZ+	Z-phase differential output +
7	AD2	Analog input 2	29	DO4+	Digital output 4 +
8	DO3-	Digital output 3 -	30	OCB	B-phase open collector output
9	-	Unused	31	OCS	Open collector command direction
10	DI3	Digital input 3	32	SIGN+	Differential command direction +
11	DO3+	Digital output 3 +	33	SIGN-	Differential command direction -
12	GND	Signal ground	34	DI5	Digital input 5
13	-	Unused	35	DO4-	Digital output 4 -
14	DO1+	Digital output 1 +	36	OCA	A-phase open collector output
15	DO2+	Digital output 2 +	37	DI2	Digital input 2
16	DI1	Digital input 1	38	OCP	Open collector command pulse

Pin	Signal	Name	Pin	Signal	Name
17	DI6	Digital input 6	39	DI4	Digital input 4
18	DI9	Digital input 9	40	24V	Internal 24V power supply
19	DO2-	Digital output 2 -	41	OB+	B-phase differential output +
20	AD1	Analog input 1	42	OB-	B-phase differential output -
21	AO1	Analog output 1	43	OA-	A-phase differential output -
22	DI10	Digital input 10	44	OA+	A-phase differential output +

4.5.2.1 Power supply signal

Signal	Pin	Name	Function
24V	40	Internal 24V power supply	24V power supply supplied internally by the drive, with a capacity of 50mA. If the actual load is higher than this value, you shall provide the power supply by themselves.
24V ground	1	24V power ground	Local 24V power ground
GND	6, 12	Signal ground	The ground of the internal power supply (except the 24V power supply) of the servo drive. The ground of the phase A/B/Z open-collector signal of the encoder and the analog output signal.
COM+	2	Common terminal of digital input	If DI is active-low (0V), COM+ connects to the positive end of external DC power (12V–24V). If DI is active-high (12V–24V), COM+ connects to the reference ground of external DC power (12V–24V).
FG	Housing	Ground of the housing	The enclosure of CN1 terminal is connected with the enclosure of the drive.

4.5.2.2 Digital signal

■ Default configuration table of position and speed mode

Signal	Pin	Name	Position mode			Speed mode		
			Default	No.	Function	Default	No.	Function
DI1	16	Digital input 1	0x003	SON	Servo enabling	0x003	SON	Servo enabling

Signal	Pin	Name	Position mode			Speed mode		
			Default	No.	Function	Default	No.	Function
DI2	37	Digital input 2	0x00D	ZRS	Zero-speed clamp	0x00D	ZRS	Zero-speed clamp
DI3	10	Digital input 3	0x004	CLA	Alarm clearing	0x004	CLA	Alarm clearing
DI4	39	Digital input 4	0x016	EMG	Emergency stop	0x016	EMG	Emergency stop
DI5	34	Digital input 5	0x019	SC1	Numerator 1 of electric gear ratio	0x00A	SPD1	Internal speed command 1
DI6	17	Digital input 6	0x01A	SC2	Numerator 2 of electric gear ratio	0x00B	SPD2	Internal speed command 2
DI7	3	Digital input 7	0x001	POT	Positive direction drive disabling	0x001	POT	Positive direction drive disabling
DI8	4	Digital input 8	0x002	NOT	Negative direction drive disabling	0x002	NOT	Negative direction drive disabling
DI9	18	Digital input 9	0x007	RPC	Clearing residual pulses	0x00E	S-SIGN	Speed command signal
DI10	22	Digital input 10	0x008	PLL	Command pulse disabling	0x006	PLC	Gain switchover
DO1+	14	Digital output 1 +	0x001	RDY	Servo ready for output	0x001	RDY	Servo ready for output
DO1-	5	Digital output 1 -						
DO2+	15	Digital output 2 +	0x003	ALM	Fault output	0x003	ALM	Fault output
DO2-	19	Digital output 2 -						
DO3+	11	Digital output 3 +	0x007	PLR	Positioning completed	0x009	COIN	Speed consistent
DO3-	8	Digital output 3 -						
DO4+	29	Digital output 4 +	0x00D	ZSO	Zero output of speed	0x00D	ZSO	Zero output of speed

Signal	Pin	Name	Position mode			Speed mode		
			Default	No.	Function	Default	No.	Function
DO4-	35	Digital output 4 -						

■ Default configuration table of torque and EtherCAT mode

Signal	Pin	Name	Torque mode			EtherCAT mode		
			Default	No.	Function	Default	No.	Function
DI1	16	Digital input 1	0x003	SON	Servo enabling	0x000	-	User defined
DI2	37	Digital input 2	0x00D	ZRS	Zero-speed clamp	0x000	-	User defined
DI3	10	Digital input 3	0x004	CLA	Alarm clearing	0x001	POT	Positive direction drive disabling
DI4	39	Digital input 4	0x016	EMG	Emergency stop	0x002	NOT	Negative direction drive disabling
DI5	34	Digital input 5	0x00A	SPD1	Internal speed command 1	0x017	HOME	Home switch
DI6	17	Digital input 6	0x00B	SPD2	Internal speed command 2	0x016	EMG	Emergency stop
DI7	3	Digital input 7	0x001	POT	Positive direction drive disabling	-	-	User defined
DI8	4	Digital input 8	0x002	NOT	Negative direction drive disabling	-	-	Unavailable
DI9	18	Digital input 9	0x00F	T-SIGN	Torque command signal	-	-	Unavailable
DI10	22	Digital input 10	0x006	PLC	Gain switchover	-	-	Unavailable
DO1+	14	Digital output 1 +	0x001	RDY	Servo ready for output	0x001	RDY	Servo ready for output
DO2+	15	Digital output 2 +	0x003	ALM	Fault output	0x003	ALM	Fault output

Signal	Pin	Name	Torque mode			EtherCAT mode		
			Default	No.	Function	Default	No.	Function
DO3+	11	Digital output 3 +	0x010	TRCH	Torque reaching	0x005	BRK	Electromagnetic brake release signal
DO4+	29	Digital output 4 +	0x00D	ZSO	Zero output of speed	-	-	User defined

 **Note:** For EtherCAT models, DI1 and DI2 can be configured to be probe 1 and probe 2. For N0 models, DI1 and DI2 are used for the probe function. If you want to reuse them for other functions, do not use the probe function simultaneously, to avoid function conflicts.

■ Function description of the digital input

Function	Signal	Function number	Applicable mode		
Positive direction drive disabling	POT	0x01	P	S	T
Negative direction drive disabling	NOT	0x02	P	S	T

This input is the drive disabling signal towards positive/negative direction. The concrete action is related to the setting of P3.40 [travel limit switch setting].

When P3.40 is set to 0 and positive direction input is disabled, the motor stops at the current position, only negative direction command input can be accepted. If the negative direction drive input is disabled, the motor stops at the current position, only positive direction command input can be accepted.

When P3.40 is set to 1, the function is invalid.

When P3.40 is set to 2, and the disabling of positive/negative drive input is valid, the drive alarms.

Function	Signal	Function number	Applicable mode		
Servo enabling	SON	0x03	P	S	T

This function indicates the control signal of the servo enabling/disabling.

If it is enabled, the drive will provide power to the motor; if it is disabled, the drive will cut off connection.

Function	Signal	Function number	Applicable mode		
Alarm clearing	CLA	0x04	P	S	T

This function indicates the control signal of alarm clearing when the drive alarms.

 **Note:** Some alarms cannot be cleared by this function. Please refer to section [10.1 Fault](#)

[codes](#) for detailed information.

Signal name	Signal	Function number	Applicable mode		
Control mode switchover	MCH	0x05	P	S	T
This function indicates the control signal of mode switching when P0.03 is set to 3, 4 and 5. When the control mode is 0, 1, 2, 6 and 7 the function input is invalid.					

Function	Signal	Function number	Applicable mode		
Gain switchover	PLC	0x06	P	S	T
This function indicates the control signal of the first and second gain switching.					

Function	Signal	Function number	Applicable mode		
Clearing residual pulses	RPC	0x07	P	-	-
This function indicates the control signal of residual pulse clearing and the detailed operation is relative to the setting of P3.45. P3.45=0 means electrical level clearing. When the digital input is valid, residual pulses will be 0. P3.45=1 means rising edge clearing. When the digital input triggers residual pulse clearing from the edge of 0→1, only clear once.					

Function	Signal	Function number	Applicable mode		
Command pulse disabling	PLL	0x08	P	-	-
This function indicates the control signal of stopping receiving the command pulse and the detailed operation is relative to the setting of P3.44. If P3.44 is set to 0, the function takes effect. When the digital input is valid, the drive suspends receiving command pulse input. If P3.44 is set to 1, the function is invalid.					

Function	Signal	Function number	Applicable mode		
Torque limit switchover	TLC	0x09	P	S	-
This function indicates the control signal of the first and second torque limit switching. For details about method setting and switching of torque limit, refer to P0.09 in chapter 9 Function description .					

Function	Signal	Function number	Applicable mode		
Internal speed command 1	SPD1	0x0A	-	S	T

Internal speed command 2	SPD2	0x0B	-	S	T
Internal speed command 3	SPD3	0x0C	-	S	-

There are 1–8 signal selections for the internal speed command in speed mode and 1–4 signal selections for the internal speed limit in torque mode.

Control mode	Set value of P0.40	SPD3	SPD2	SPD1	Related parameter and set value
Speed mode	0	0	0	0	P0.46 internal speed 1
		0	0	1	P0.47 internal speed 2
		0	1	0	P0.48 internal speed 3
		0	1	1	P0.49 internal speed 4
		1	0	0	P0.50 internal speed 5
		1	0	1	P0.51 internal speed 6
		1	1	0	P0.52 internal speed 7
		1	1	1	P0.53 internal speed 8
Torque mode	0	0	0	0	P0.46 speed limit 1
		0	0	1	P0.47 speed limit 2
		0	1	0	P0.48 speed limit 3
		0	1	1	P0.49 speed limit 4

Function	Signal	Function number	Applicable mode		
Zero-speed clamp	ZRS	0x0D	-	S	T

This function indicates the control signal of zero speed clamp. The detailed action is associated with the setting of P0.58 (Zero speed clamp mode).

Function	Signal	Function number	Applicable mode		
Speed command signal	S-SIGN	0x0E	-	S	-

This function indicates signal selection for the speed command input in speed control mode, and the detailed operation is relative to the setting of P0.41.

When P0.41 is set to 1, the digital input function is valid.

When P0.41 is set to 0, the digital input function is invalid.

Function	Signal	Function number	Applicable mode		
Torque command signal	T-SIGN	0x0F	-	-	T

This function indicates signal selection for the torque command input in torque control mode, and the detailed operation is relative to the setting of P0.61.

When P0.61 is set to 1, the digital input function is valid.

When P0.61 is set to 0, the digital input function is invalid.

Function	Signal	Function number	Applicable mode		
Internal position command 1	POS1	0x10	P	-	-
Internal position command 2	POS2	0x11	P	-	-
Internal position command 3	POS3	0x12	P	-	-
Internal position command 4	POS4	0x13	P	-	-
Internal position command 5	POS5	0x20	P	-	-
Internal position command 6	POS6	0x21	P	-	-
Internal position command 7	POS7	0x22	P	-	-

These functions are the signal selections of 0–127 in the PTP (point-to-point) control mode. It has the same function with P5.20 and is valid when P0.20 is 2.

The combination of 7 digital inputs is used to select the different PTP position of PtP0.00–PtP2.55 and the corresponding target speed, ACC/DEC time and the delay time of P5.21–P5.68.

Control mode	POS7	POS6	POS5	POS4	POS3	POS2	POS1	Related parameter and set value
Position mode	0	0	0	0	0	0	0	PtP0.01 (Position of segment 00)
	0	0	0	0	0	0	1	PtP0.03 (Position of segment 01)
	0	0	0	0	0	1	0	PtP0.05 (Position of segment 02)
	0	0	0	0	0	1	1	PtP0.07 (Position of segment 03)
	0	0	0	0	1	0	0	PtP0.09 (Position of segment 04)
	0	0	0	0	1	0	1	PtP0.11 (Position of segment 05)
	0	0	0	0	1	1	0	PtP0.13 (Position of segment 06)
	0	0	0	0	1	1	1	PtP0.15 (Position of segment 07)
	0	0	0	1	0	0	0	PtP0.17 (Position of segment 08)
	0	0	0	1	0	0	1	PtP0.19 (Position of segment 09)
0	0	0	1	0	1	0	PtP0.21 (Position of segment 10)	

Function			Signal			Function number		Applicable mode		
0	0	0	1	0	1	1	PtP0.23 (Position of segment 11)			
0	0	0	1	1	0	0	PtP0.25 (Position of segment 12)			
x	x	x	x	x	x	x	xxx			
	1	1	1	1	1	0	PtP2.53 (Position of segment 126)			
1	1	1	1	1	1	1	PtP2.55 (Position of segment 127)			

Function			Signal			Function number		Applicable mode		
External fault			EXT			0x14		P	S	T
This function indicates the alarm signal of external input fault. If the digital input is valid, the drive will report Er10-3 and stop.										

Function			Signal			Function number		Applicable mode		
Inertia ratio switchover			JC			0x15		P	S	T
This function indicates the control signal of inertia ratio switching between the first inertia ratio and the second inertia ratio. When the digital input is valid, the internal software uses P1.02; and when invalid, use P1.01.										

Function			Signal			Function number		Applicable mode		
Emergency stop			EMG			0x16		P	S	T
This function indicates the control signal of emergency stop. If P3.41 is set to 0 and when the digital input is valid, the drive will stop to report Er10-4.										

Function			Signal			Function number		Applicable mode		
HOME switch input			HOME			0x17		P	-	-
This function indicates the input signal of HOME SWITCH. When the drive carries out HOME action, in some HOME mode, if the digital input is detected to be valid, HOME action is finished. See P5.10 for details.										

Function			Signal			Function number		Applicable mode		
Triggering homing			HTRG			0x18		P	-	-

This function indicates the trigger control signal of HOME function, and the rising edge is valid.

The digital input function has the same function with P5.15.

Function	Signal	Function number	Applicable mode		
Numerator 1 of electric gear ratio	SC1	0x19	P	-	-
Numerator 2 of electric gear ratio	SC2	0x1A	P	-	-

The function is the selection signal of the electric gear ratio, up to 4 groups of electric gears can be switched.

Before using the function, it is necessary to set P0.22 to 0 and then set different electric gear ratio (P0.25–P0.29).

Note: If the electric gear is switched by digital value, it is necessary to set P4.10 to 0.

SC1	SC2	Electronic gear ratio	
		Numerator	Denominator
0	0	P0.25	P0.26
1	0	P0.27	P0.26
0	1	P0.28	P0.26
1	1	P0.29	P0.26

Function	Signal	Function number	Applicable mode		
PTP control trigger	TRIG	0x1B	P	-	-

In the PTP control mode, it needs to be used with internal position command 1–4.

During using, select the target step by the internal position command selection 1–4, and then trigger the switching action selected by target step via the rising edging of this digital value.

Function	Signal	Function number	Applicable mode		
Input switchover for vibration suppression	VS-SEL	0x1C	P	-	-

The function is the control signal of the first and the second vibration control frequency switching.

When the digital input is valid, the internal software uses P1.38; when invalid, use P1.36.

Function	Signal	Function number	Applicable mode		
Quick stop	Q-STOP	0x1D	P	S	T

This function indicates the signal of the fast stop of external control.

When the digital input is valid, the motor decelerates to 0 from current speed at the curve set by P0.69; when the input is invalid, the motor will restore to the operation state before stop.

Function	Signal	Function number	Applicable mode		
PTP control stop	PTP-ST	0x1E	P	-	-

This function indicates the control signal of stopping PTP operation in the PTP control mode. In the bus control mode, it has the same function with P5.20 when it is 2048.

Function	Signal	Function number	Applicable mode		
Absolute position clearing	PCLR	0x1F	P	-	-

This function indicates the control signal of clearing the multi-turn absolute encoder. When this digital input is valid, the multi-turn data of the encoder will be cleared while the single-turn data remains unchanged, however, the absolute position feedback of the system will be cleared.

Function	Signal	Function number	Applicable mode		
Forward jogging	FJOG	0x23	P	-	-

This function indicates the control signal of forward jogging. When this digital input is valid, forward jogging operation will be applied.

Function	Signal	Function number	Applicable mode		
Reverse jogging	RJOG	0x24	P	-	-

This function indicates the control signal of reverse jogging. When this digital input is valid, reverse jogging operation will be applied.

Function	Signal	Function number	Applicable mode		
High/low speed switching of jogging	JOGC	0x25	P	-	-

This function indicates the control signal of jogging high/low speed switching. When this digital input is valid, high speed jogging will be applied.

Function	Signal	Function number	Applicable mode		
JOG function of the terminal	DJOG	0x2C	P	-	-

This function indicates the control signal of terminal JOG function. When this digital input is valid, JOG function of the terminal is valid.

Function	Signal	Function number	Applicable mode		
Gantry synchronization input clear	GIN	0x2D	P	-	-
This function indicates the control signal of gantry synchronization input clearing.					

Function	Signal	Function number	Applicable mode		
Master gantry synchronization alignment sensor	GSM	0x2E	P	-	-
This function indicates the control signal of master gantry synchronization alignment sensor.					

Function	Signal	Function number	Applicable mode		
Slave gantry synchronization alignment sensor	GSS	0x2F	P	-	-
This function indicates the control signal of slave gantry synchronization alignment sensor.					

Function	Signal	Function number	Applicable mode		
Dynamic braking relay feedback	DBS	0x30	P	S	T
This function indicates the control signal of dynamic braking relay feedback. When this digital input is valid, the dynamic braking relay will be closed.					

Function	Signal	Function number	Applicable mode		
Manual and automatic switching of turret	DAT	0x31	P	-	-
This function indicates the control signal of turret manual and automatic switching. When this digital input is valid, the turret is manual mode.					

Function	Signal	Function number	Applicable mode		
Forward jogging of turret	DFJ	0x32	P	-	-
This function indicates the control signal of turret forward jogging. When this digital input is valid, the turret is forward jogging.					

Function	Signal	Function number	Applicable mode		
Reverse jogging of turret	DRJ	0x33	P	-	-
This function indicates the control signal of turret reverse jogging. When this digital input is					

valid, the turret is reverse jogging.

Function	Signal	Function number	Applicable mode		
Switching between fully-closed loop and semi-closed loop	FCS	0x34	P	-	-
This function indicates the control signal of switching between fully-closed loop and semi-closed loop. This function is valid only when P0.38 [enable fully-closed loop] is set to 2 [enable]. When this digital quantity is valid, it is semi-closed loop; if invalid, it is fully-closed loop.					

Function	Signal	Function number	Applicable mode		
PTP terminal pause	PSTOP	0x35	P	-	-
This function indicates the control signal of PTP terminal pause. When this digital input is valid, jog control operation pauses.					

Function	Signal	Function number	Applicable mode		
EzJOG terminal pause	ESTOP	0x36	P	-	-
This function indicates the control signal of EzJOG terminal pause. When this digital input is valid, EzJOG operation pauses.					

■ Function description of the digital output

Function	Signal	Function number	Applicable mode		
Servo ready for output	RDY	0x01	P	S	T
This function indicates the state signal of the enabled drive. When valid, the drive can be enabled and provide power to the motor and when invalid, the drive gives no response to the command.					

Function	Signal	Function number	Applicable mode		
Servo run output	RUN	0x02	P	S	T
This function indicates the state signal of the enabled drive. When valid, the motor is power on.					

Function	Signal	Function number	Applicable mode		
Fault output	ALM	0x03	P	S	T
The function indicates the state signal when the drive displays the fault alarm. When it is					

valid, a fault occurs to the drive.

Function	Signal	Function number	Applicable mode		
Electromagnetic brake release signal	BRK	0x05	P	S	T

The function indicates the control signal of electromagnetic brake release. When it is valid, the control brake is released and then it receives the motor control command; when invalid, the control brake will be disconnected.

Function	Signal	Function number	Applicable mode		
Position command validity	PCMD	0x06	P	-	-

The function indicates the state signal of whether there is position command or not. When it is valid, the motor is controlled by the non-zero position command.

Function	Signal	Function number	Applicable mode		
Positioning completed	PLR	0x07	P	-	-

The function indicates the state signal of positioning finished. When it is valid, the positioning is finished.

Function	Signal	Function number	Applicable mode		
Control mode switchover status	MCHS	0x08	P	S	T

This function indicates the state signal during control mode switching in output compound control mode. When it is valid, control mode 1 is switched to mode 2; if the function output is invalid, the control mode 2 is switched back to mode 1.

Function	Signal	Function number	Applicable mode		
Speed consistent	COIN	0x09	P	S	T

The function indicates the state signal of speed consistent. When it is valid, the deviation between current speed feedback and speed command is in the range of P3.53.

Function	Signal	Function number	Applicable mode		
Speed reached	SR	0x0A	P	S	T

The function indicates the state signal of output speed reaching. When it is valid, the current speed feedback is in the setting value of P3.54.

Function	Signal	Function number	Applicable mode		
Speed being limited	SL	0x0B	-	-	T
The function indicates the state signal of output speed limiting. When it is valid, in the torque mode, if the current torque does not reach the torque command, the speed feedback is in the speed limiting.					

Function	Signal	Function number	Applicable mode		
Speed command validity	SCMD	0x0C	P	S	T
The function indicates the state signal of whether there is speed command or not. When it is valid, non-zero speed command controls the motors.					

Function	Signal	Function number	Applicable mode		
Zero output of speed	ZSO	0x0D	P	S	T
The function indicates the state signal of whether the current speed feedback is 0.					

Function	Signal	Function number	Applicable mode		
Torque being limited	LM	0x0E	P	S	T
The function indicates the state signal of torque limiting. When it is valid, it means current torque output has reached the max. torque limit setting.					

Function	Signal	Function number	Applicable mode		
Zeroing completed	HEND	0x0F	P	-	-
The function indicates the state signal of zeroing completed. When it is valid, the drive has finished returning to zero and found zero position successfully.					

Function	Signal	Function number	Applicable mode		
Torque reaching	TRCH	0x10	-	-	T
The function indicates the state signal of torque reaching. When it is valid, the deviation between current torque output and torque command will be in the setting range of P3.59; there is 5% detection retention.					

Function	Signal	Function number	Applicable mode		
PTP arrival	PTPF	0x16	P	-	-
The function indicates the state signal of output PTP reaching.					

Function	Signal	Function number	Applicable mode		
PTP output 1	PTPO1	0x17	P	-	-
The function indicates the state signal of PTP output 1.					

Function	Signal	Function number	Applicable mode		
PTP output 2	PTPO2	0x18	P	-	-
The function indicates the state signal of PTP output 2.					

Function	Signal	Function number	Applicable mode		
PTP output 3	PTPO3	0x19	P	-	-
The function indicates the state signal of PTP output 3.					

Function	Signal	Function number	Applicable mode		
PTP output 4	PTPO4	0x1A	P	-	-
The function indicates the state signal of PTP output 4.					

Function	Signal	Function number	Applicable mode		
PTP output 5	PTPO5	0x1B	P	-	-
The function indicates the state signal of PTP output 5.					

Function	Signal	Function number	Applicable mode		
PTP output 6	PTPO6	0x1C	P	-	-
The function indicates the state signal of PTP output 6.					

Function	Signal	Function number	Applicable mode		
PTP output 7	PTPO7	0x1D	P	-	-
The function indicates the state signal of PTP output 7.					

Function	Signal	Function number	Applicable mode		
Gantry synchronization output clear	GSC	0x1E	P	-	-
The function indicates the state signal of gantry synchronization output clearing.					

Function	Signal	Function number	Applicable mode		
			P	S	T
Dynamic braking relay control	DBRC	0x1F			
The function indicates the control signal of dynamic braking relay.					

4.5.2.3 Pulse input signals and functions

Signal	Pin	Name	Function
OCP	38	Position command pulse input 1	In the position control mode, act as the position command input terminal. In other control mode, the terminal is invalid.
PULS+	23		
PULS-	24		
OCS	31	Position command pulse input 2	Allowed Max. input pulse frequency: 4MHz in differential motion mode, 200kHz in open-collector mode.
SIGN+	32		
SIGN-	33		

4.5.2.4 Analog input signals and functions

Signal	Pin	Name	Default	Function	Function
AD1	20	Analog input 1	0x00	Invalid	The accuracy of AD1 and AD2 is 12-bit. External analog input terminals. The input impedance is 10kΩ. The input voltage range is -10V~+10V. A voltage exceeding ±11V may damage the drive. The range and offset setting and function definition can be set.
AD2	7	Analog input 2	0x03	Velocity	
GND	6, 12	Signal ground	-	-	

4.5.2.5 Encoder output signals and functions

Signal	Pin	Name	Function
OA+	44	A phase output	Output the frequency divided encoder signal, comply with the standard of TIA/EIA-422-B.
OA-	43		
OB+	41	B phase output	The output phase A pulse and phase B pulse is still quadrature. When it rotates forward, phase A leads phase B by 90°. When it rotates in reverse, phase B leads phase A by 90°.
OB-	42		
OZ+	28	Z phase output	Frequency division and frequency multiplication with any integer and decimal fraction is allowable. The output signals have no isolation.
OZ-	27		
OCA	36	A phase output	Output the open-collector signal of phase A, without isolation.
OCB	30	B phase	Output the open-collector signal of phase B, without

Signal	Pin	Name	Function
		output	isolation.
OCZ	26	Z phase output	Output the open-collector signal of phase Z, without isolation.
GND	6, 12	Signal ground	The ground of the phase A/B/Z output open collector signal of the encoder

4.5.2.6 Analog output signals and functions

Signal	Pin	Name	Function
AO1	21	Analog output 1	Its output function definition can be set, and the range and offset settings can be set.
AO2	25	Analog output 2	Its output function definition can be set, and the range and offset settings can be set.
GND	6, 12	Signal ground	Ground of analog output signal

4.5.3 CN1 wiring instruction

4.5.3.1 Wiring of digital input circuit

The following takes DI1 for example. The circuit of DI1–DI10 interface is the same.

Wiring when using the user-provided power supply:

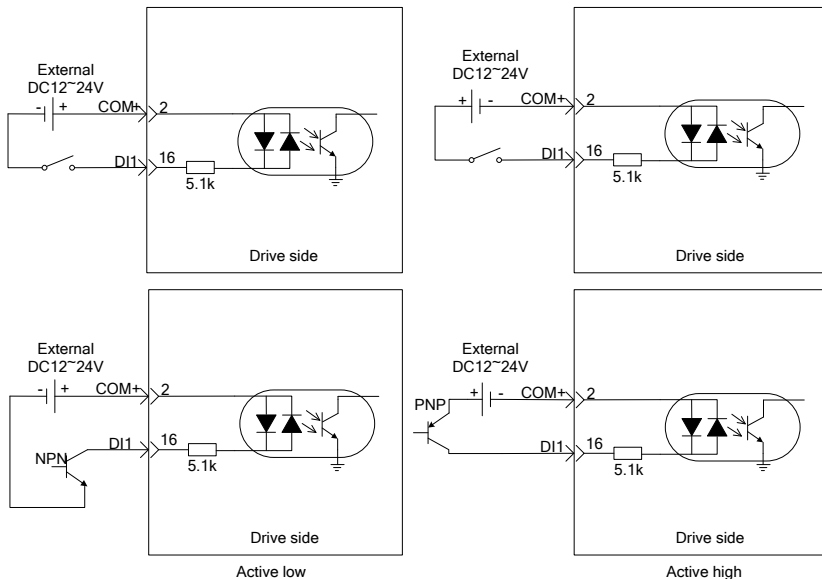

Wrong wiring method: Mixing of triodes

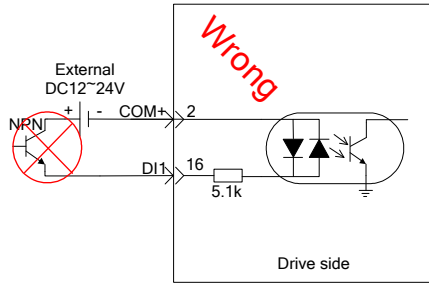
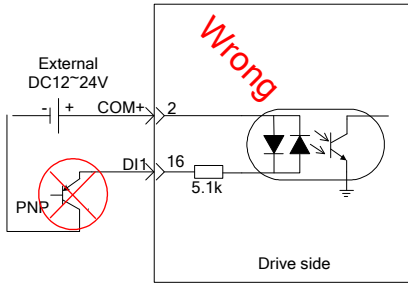

Wiring when using the local-provided power supply:

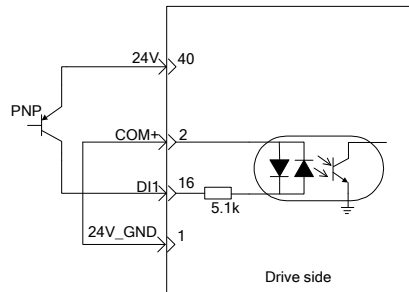
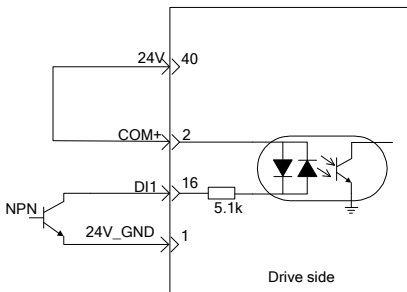
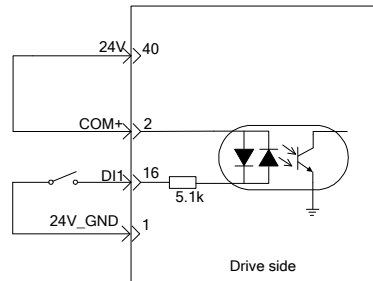
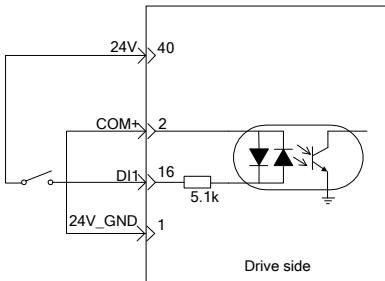

- The digital input circuit has two connection methods: a mechanical switch connection as shown in the figure and an open collector connection for triodes (NPN and PNP types, but the two cannot be mixed).
- Either the 24V power supply with a maximum current of 100mA carried by the servo driver or the user-provided 12V–24V power supply can be used as the 24V power supply.

4.5.3.2 Wiring of the pulse input circuit

Connection mode 1: Differential mode

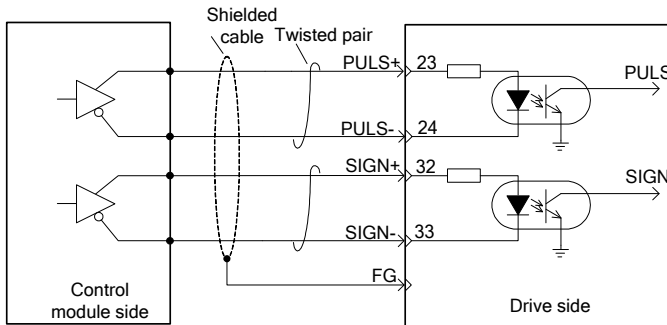

Wrong connection: The shielded cable is not connected to the FG end of the drive.

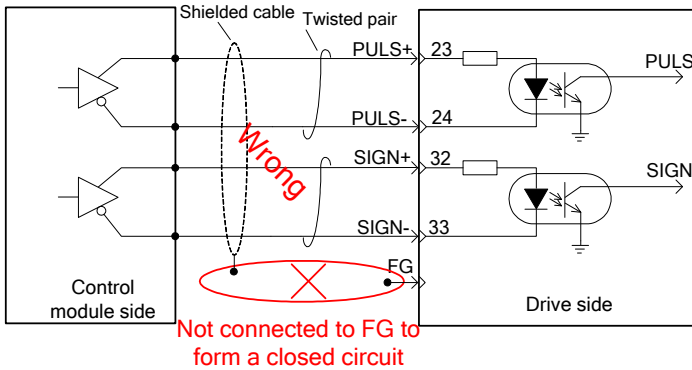

- The maximum frequency of input pulse is 4MHz and the input signal voltage is $\pm 5V$.
- With the best anti-noise capability, this signal transmit method is recommended as the preferred.

Connection mode 2: Open collector mode 1

The control module is NPN type (common cathode):

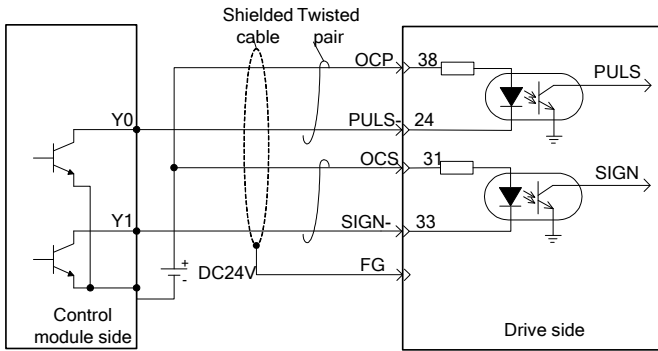

The control module is PNP type (common anode):

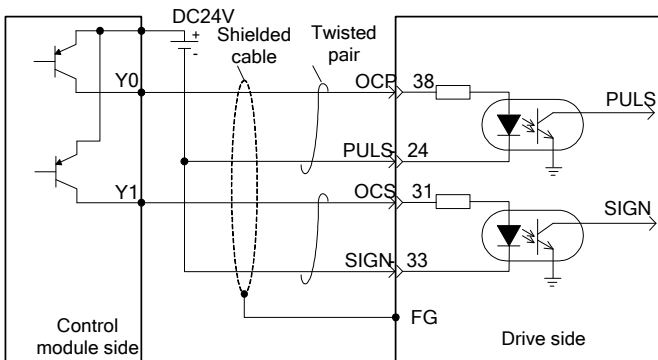

Connection mode 3: Open collector mode 2

The control module is NPN type (common cathode):

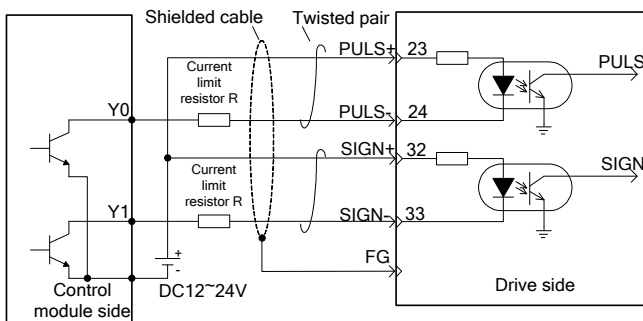

Wrong connection 1: Only one current-limiting resistor R is added, and the other current-limiting resistor R is lacked.

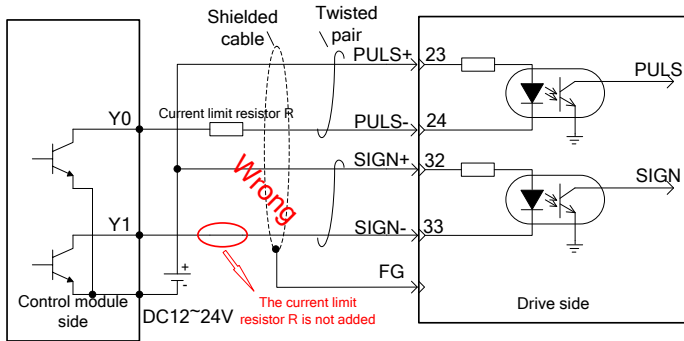

Wrong connection 2: Two current-limiting resistors R are not added.

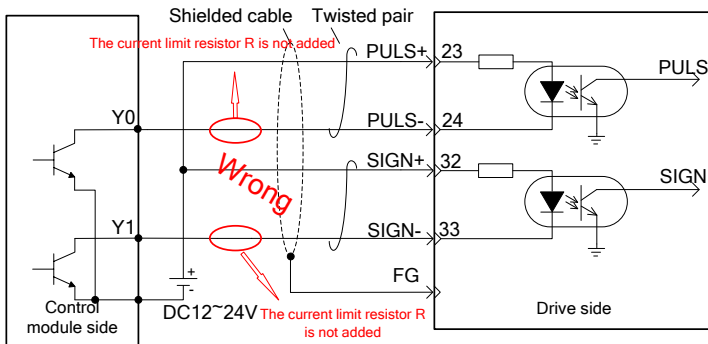

The control module is PNP type (common anode):

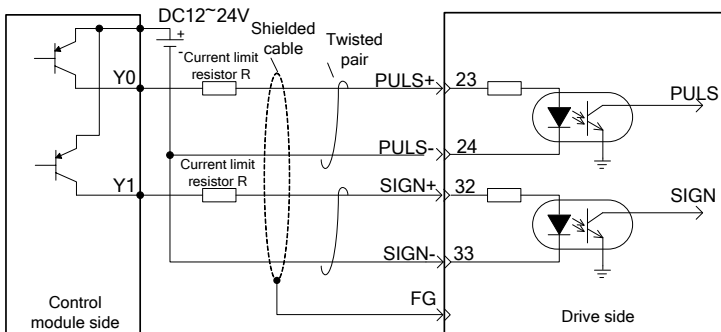

Wrong connection 1: Only one current-limiting resistor R is added, and the other

current-limiting resistor R is lacked.

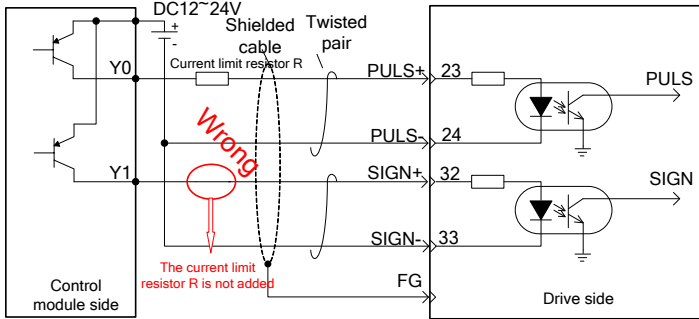

Wrong connection 2: Two current-limiting resistors R are not added.

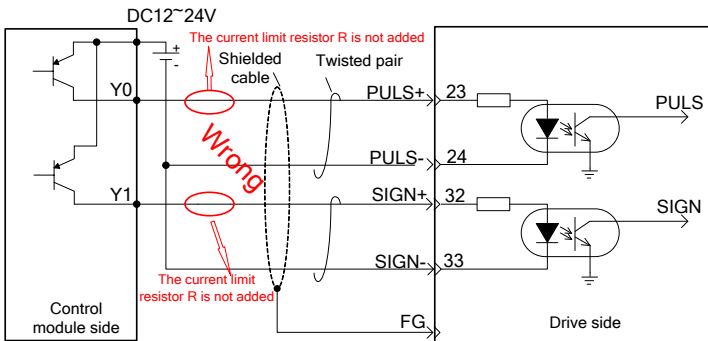

Wrong connection 3: SIGN port is not connected, and no signal can be received.

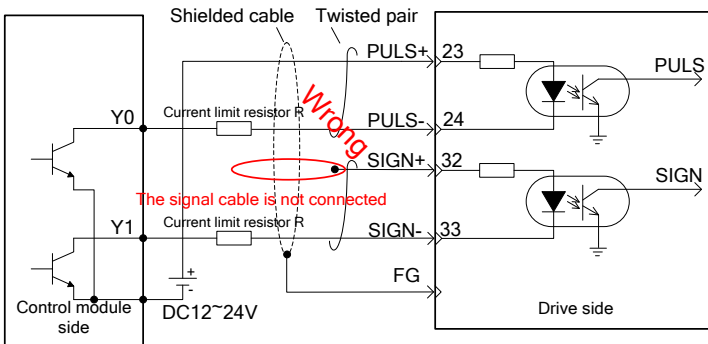

The input pulse frequency is 200kHz. If the 12–24V power supply provided by you is used, it is required to connect to current-limiting resistor (the resistance is selected as the below table).

V _{DC}	Resistor parameter
12V	1kΩ, 1/4W
24V	2kΩ, 1/3W

$$\frac{V_{DC}-1.5}{R+68} \approx 10(\text{mA})$$

For above three methods, the shielded twisted-pair cables must be used and the length should be less than 3m.

4.5.3.3 Wiring of the analog input circuit

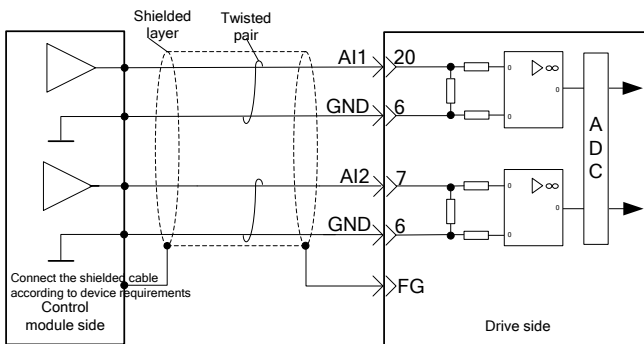

There are two analog input circuits, AI1 and AI2. The input impedance is 10kΩ. The input voltage range is -10V–+10V. If the voltage is higher than ±11V, the circuits may be damaged.

4.5.3.4 Wiring of digital output circuit

The following takes DO1 for example. The circuit of DO1–DO4 interface is the same.

Wiring when using the user-provided power supply:

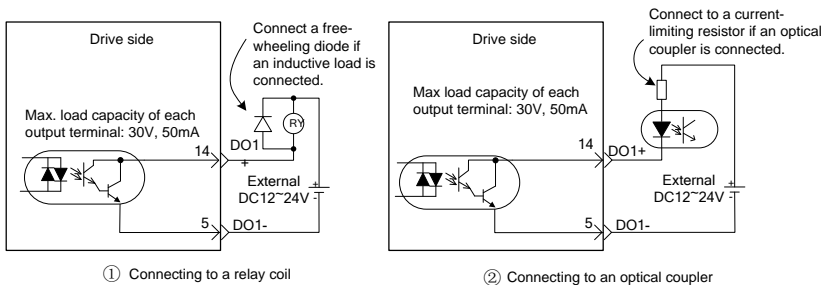

Wrong wiring:

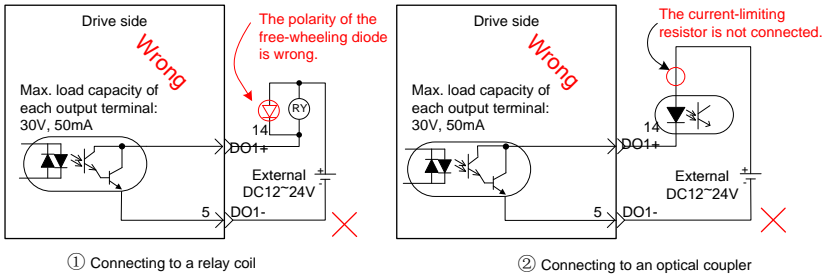

Wiring when using the local-provided power supply:

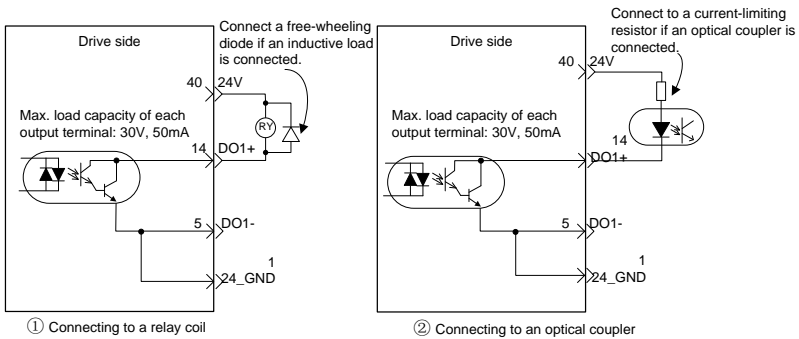

- There are four digital output circuits, all of which are open-collector output structures. They can be used to drive relay coils or optocoupler loads with the load capacity shown in the figure.
- When connecting inductive loads such as relay coils, install current-continuing diodes in the way shown in the figure. When connecting optocouplers, a current-limiting resistor must be connected; otherwise, damage to the drive may occur.
- The local 24V power supply can only provide a maximum current of 100mA. If the actual load current exceeds 100mA, please use your own power supply with the recommended capacity of 500mA.

4.5.3.5 Wiring of frequency division output circuit of encoder feedback signal

Differential mode:

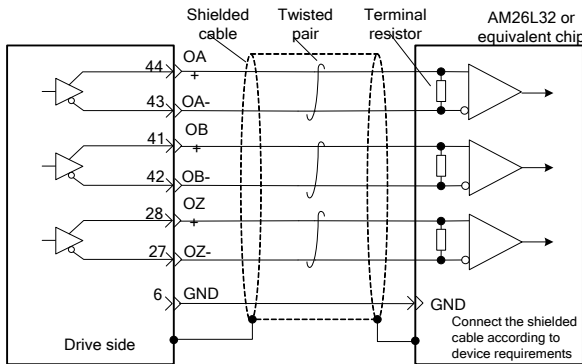

Open-collector mode: take OCZ as an example

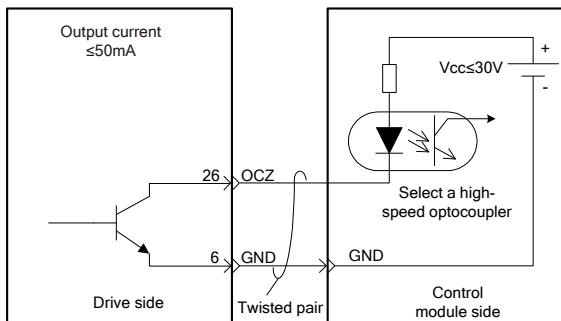

- Phase A, B and Z all provide differential output and open-collector output signals.
- For differential output signal, it is recommended to use AM26C32 or equivalent differential receiving chip and be sure to fit a terminal matching resistor of about 220Ω.
- For the phase A, B, Z signal of open-collector output, as the signal pulse width is very narrow, you shall use high speed optical coupler to receive this signal.
- Both output circuits have no isolation.

4.5.3.6 Wiring of the analog output circuit

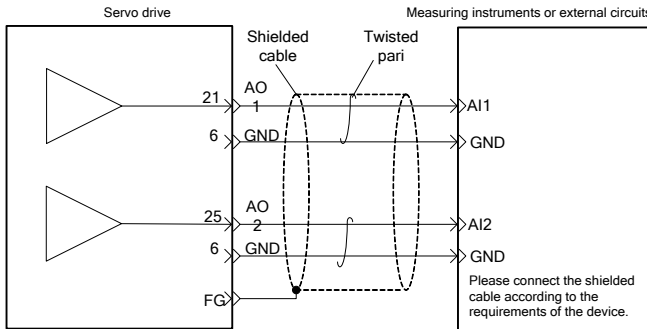

There are two analog output circuits in all. The output voltage range is -10V~10V. The Max output current is 3mA.

4.6 Wring with the motor

Figure 4-6 Wiring with the motor

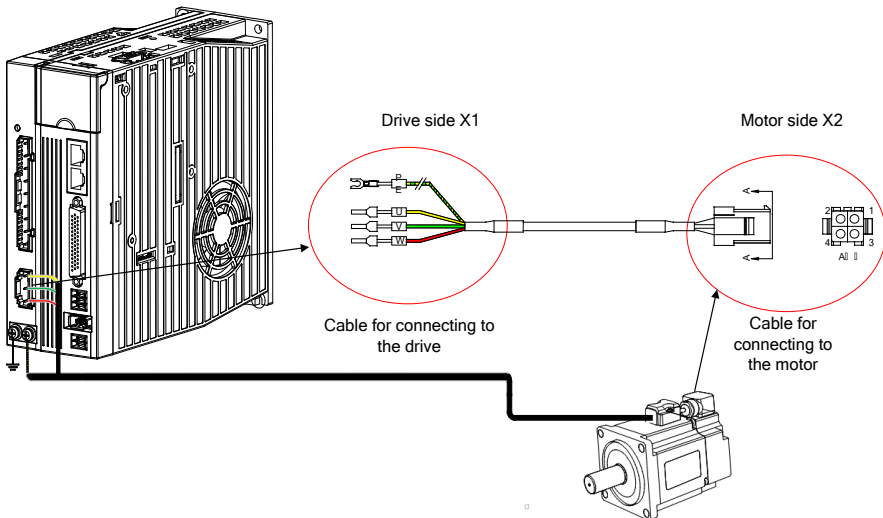

4.6.1 Wiring for 220V 400W–1kW models using 40/60/80-base motor

Figure 4-7 IMS20A series motor wiring

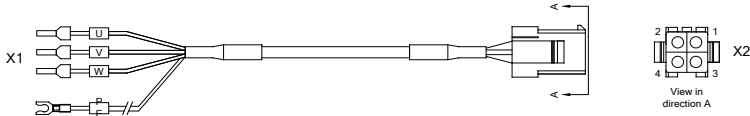

Table 4-1 Drive side X1 and motor side X2 terminal description

Base	Signal	X1	X2
		Terminal type	Terminal pin
40, 60, and 80	U	Tubular terminal	2
	V	Tubular terminal	1
	W	Tubular terminal	3
	PE	Fork-type terminal	4

Figure 4-8 IMS20B series motor wiring



Table 4-2 Drive side X1 and motor side X2 terminal description

Base	Signal	X1	X2
		Terminal type	Terminal pin
40, 60, and 80	W	Tubular terminal	3
	V	Tubular terminal	1
	U	Tubular terminal	2
	PE	Fork-type terminal	4
	24V	Tubular terminal	A
	GND	Tubular terminal	B

4.6.2 Wiring for 220V 2kW–3kW and 380V 1.5kW–7.5kW models using 100/130/180-base motor

Figure 4-9 Motor wiring

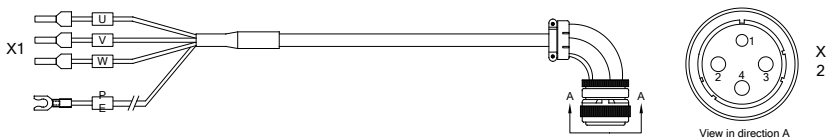

Table 4-3 Drive side X1 and motor side X2 terminal description

Base	Signal	X1	X2
		Terminal type	Terminal pin
100, 130, and 180	U	Tubular terminal	2
	V	Tubular terminal	3
	W	Tubular terminal	4
	PE	Fork-type terminal	1

Note: Use YD28 size for flange motor X2 using 100/130-base and YD32 size for flange motor X2 using 180-base.

4.7 Wiring with the encoder

Figure 4-10 Wiring with the encoder

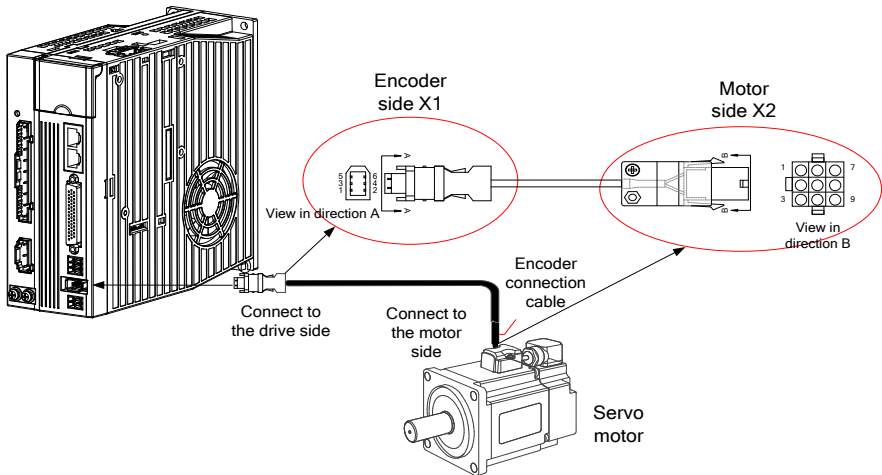

4.7.1 Wiring for models using 40/60/80-base absolute encoder motor

Figure 4-8 IMS20A series absolute encoder motor wiring

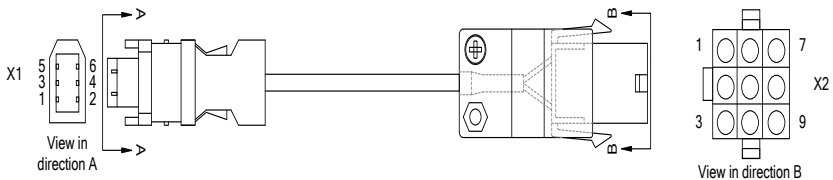

Table 4-4 Drive side X1 and absolute encoder motor side X2 terminal description

Base model No.	Signal	X1 pin	X2 pin	Structure of core wire
40, 60, and 80	SD+	5	1	Twisted pair
	SD-	6	2	
	5V	1	6	Twisted pair
	GND	2	7	
	VB+	-	3	Twisted pair
	VB-	-	8	
	PE	Iron shell	9	Woven

Figure 4-9 IMS20B series motor wiring

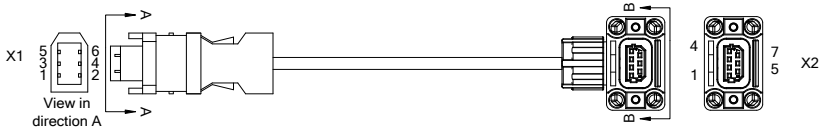

Table 4-5 Drive side X1 and motor side X2 terminal description

Base model No.	Signal	X1 pin	X2 pin	Structure of core wire
40, 60, and 80	SD+	5	1	Twisted pair
	SD-	6	2	
	5V	1	5	Twisted pair
	GND	2	6	
	VB+	-	3	Twisted pair
	VB-	-	4	
	PE	Iron shell	7	Woven

4.7.2 Wiring for models using 100/130/180-base absolute encoder motor

Figure 4-10 Absolute encoder motor wiring

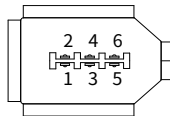

Table 4-6 Drive side X1 and absolute encoder motor side X2 terminal description

Base model No.	Signal	X1 pin	X2 pin	Structure of core wire
100, 130, and 180	SD+	5	2	Twisted pair
	SD-	6	3	
	5V	1	4	Twisted pair
	GND	2	5	
	VB+	-	6	Twisted pair
	VB-	-	7	
	PE	Iron shell	1	Woven

4.8 Function

4.8.1 Encoder terminal (CN2)



CN2 port function			
Pin	Signal	Function	Remarks
1	5V	5V power supply	Different encoders use different cables
2	GND	Power ground	
3	CLK+	BISS/Endat clock output+	
4	CLK-	BISS/Endat clock output-	
5	SD+	Serial encoder data+	
6	SD-	Serial encoder data-	

4.8.2 RS485/CAN terminal(CN3)

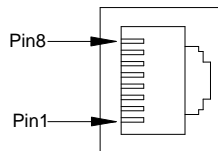

CN3 port function table			
Pin	Signal	Function	Remarks
1	CAN_H	CAN data +	RS485 and CAN use the same interface and each signal has
2	CAN_L	CAN data -	

CN3 port function table			
Pin	Signal	Function	Remarks
3	CAN_GND	CAN signal ground	two pins for multiple networking.
4	RS485+	RS485 data +	
5	RS485-	RS485 data -	
8	GND	RS485 GND	
6, 7	-	Unused	

Note: EtherCAT bus-type drive, this port is standard network cable port definition, namely pin 1, 2, 3 and 6 correspond to Tx+, Tx-, Rx+ and Rx- respectively.

4.8.3 USB terminal (CN4)

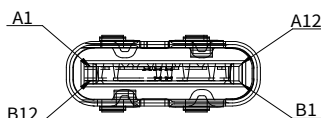

CN4 USB port function table			
Pin	Signal	Function	Remarks
A7, B7	USB-	Data-	Standard type-c interface.
A6, B6	USB+	Data+	
A1, A12, B1, B12	GND	Signal ground	
A4, B4, A5, B5, A9, B9	-	Unused	

4.8.4 Second encoder (CN5)

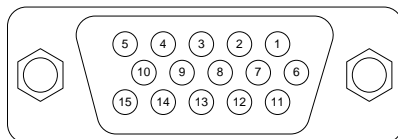

CN5 port function			
Pin	Signal	Function	Remarks
1	-	-	Connect to linear encoder or the second encoder, supporting incremental linear motor encoder.
2	-	-	
3	ENC_A+	Incremental encoder A+	
4	ENC_A-	Incremental encoder A-	
5	5V	Power supply +5V	

CN5 port function			
Pin	Signal	Function	Remarks
6	-	-	
7	V	Single-end hall V signal	
8	W	Single-end hall W signal	
9	ENC_B-	Incremental encoder B-	
10	ENC_B+	Incremental encoder B+	
11	U	Single-end hall U signal	
12	GND	Power ground, be connected with internal GND	
13	ENC_Z-	Incremental encoder Z-	
14	ENC_Z+	Incremental encoder Z+	
15	PTC	Motor temperature feedback input	

4.8.5 STO safety function introduction

The STO safety function (Safe Torque Off) is a safety function in which the hardware shuts off the motor current by blocking the PWM. After starting the STO function, you can carry out short-time operations (such as non-electrical cleaning in the lathe industry) or maintenance and repair on non-electrical parts of the equipment when the drive is not powered off. Its function implementation is shown in the figure below:

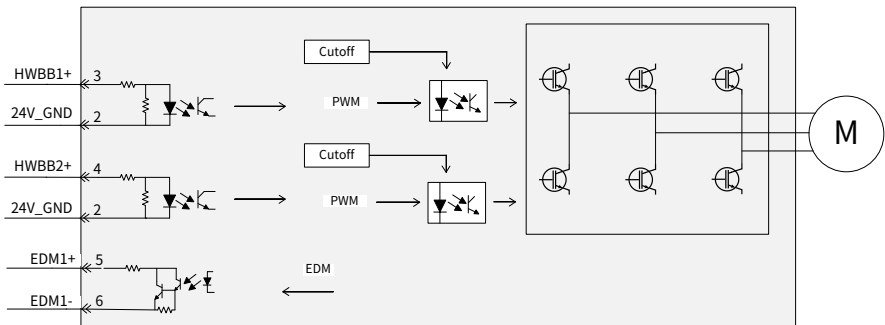

4.8.5.1 STO port (CN7)

The port where the STO function is located is CN7, and its schematic diagram, wiring diagram, port pin wiring definition and function description table are as follows:

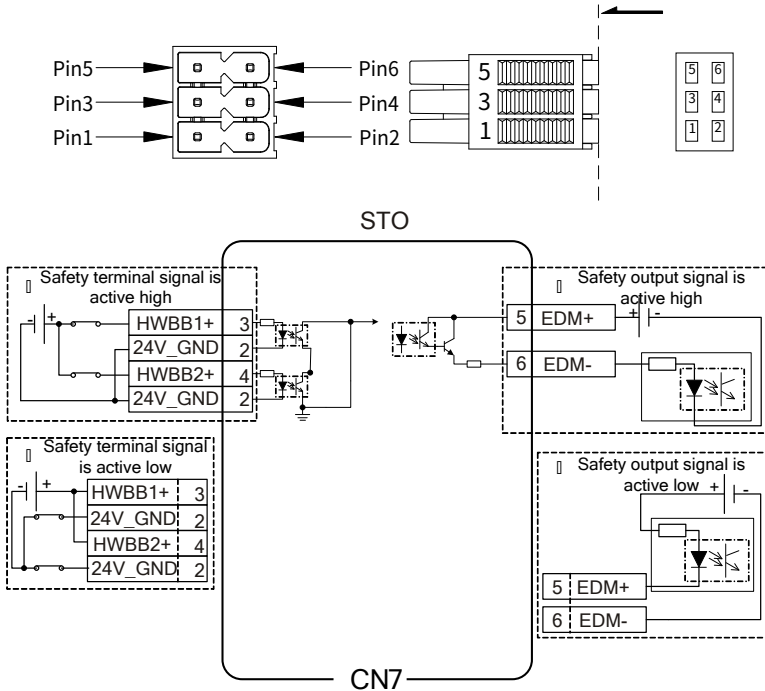

CN7 port function			
Pin	Signal	Function	Remarks
1	24V	Internal power 24V	Internal power 24V cannot be used as external power supply
2	24V_GND	Internal power 24V ground	
3	HWBB1+	Safety input 1+	
4	HWBB2+	Safety input 2+	
5	EDM+	Safety monitoring output +	
6	EDM-	Safety monitoring output-	

To make the commissioning process more user-friendly, the pins for the supply voltage (+24V) have been added and the drive is configured with STO terminals. If the safety circuit is installed and the STO function is not required, HWBB1+ and HWBB2+ need to be connected to 24V.

Note: If it is necessary to use STO in the application, the short jumper must be removed.

4.8.5.2 STO function logic table

When any one of the corresponding input optocouplers of HWBB1 and HWBB2 is disconnected, the drive will be disabled (without distinguishing between brake and non-

brake) within 20ms (STO response time). At this time, the system stops enabling, the LED panel displays STO_IN, and the safety output signal EDM is valid.

STO function table			
HWBB1 input	HWBB2 input	PWM signal	EDM output
ON	ON	Normal	OFF
ON	OFF	Lockout	ON
OFF	ON	Lockout	ON
ON	ON	Normal	OFF
OFF	OFF	Lockout	ON

4.8.5.3 STO action timing sequence

STO action timing diagram during normal operation of the servo drive:

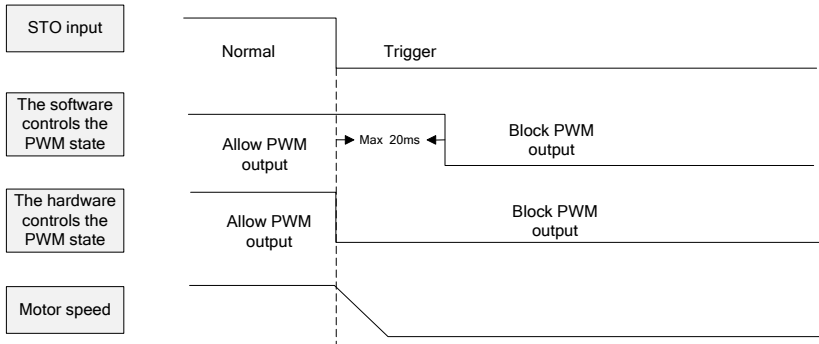

4.8.5.4 STO fault detection monitoring (EDM)

The fault detection monitoring (EDM) output is used to monitor the STO circuit or the signals of wiring fault between safety devices and STO inputs. The relationship between the STO input signal and the fault detection monitoring output is shown in the following table:

Signal name	Logical relationship			
HWBB1 input	ON	ON	OFF	OFF
HWBB2 input	ON	OFF	ON	OFF
EDM output	OFF	ON	ON	ON

The safety function is activated by setting the two STO input signals to OFF, and the EDM output signal will turn ON after about 40us.

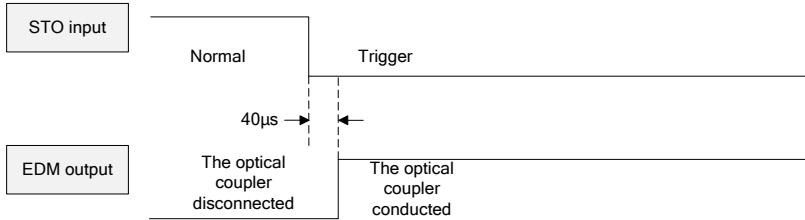

4.8.5.5 STO function test

If you do not use the STO function, you can insert the STO shorting cap supplied by the factory, which has been short-circuited wiring, and you can read the STO status through R2.51, at this time, STO is in the invalid state. When you pull out the shorting cap, the LED panel displays STO_IN, at this time, the STO function will play a role in the blocking of PWM, and R2.51 is in the valid state of STO.

If you want to trigger the STO function externally, please connect the signals for the safety function according to the following figure, in which the input signal uses the 0V common terminal.

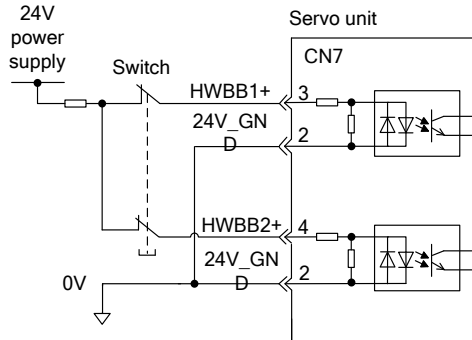

When the LED panel reports a fault during the commissioning process, you can find the cause and solution according to the following table:

STO fault table			
Fault code	Name	Possible cause	Solution
Er10-9	Hardware fault-STO phase loss	There are two phase loss in safety terminal input	Check the safety terminal input wiring.
Er10-a	Hardware fault-STO DPIN1 fault	Safety terminal input 1 is abnormal.	Check the safety terminal input wiring.
Er10-b	Hardware fault-STO DPIN2 fault	Safety terminal input 2 is abnormal.	Check the safety terminal input wiring.

STO fault table			
Fault code	Name	Possible cause	Solution
Er10-e	STO terminal fault	The STO function is set to disable, and the STO terminals are not plugged in.	Check whether STO terminal is inserted. Check whether the wiring of STO terminal is proper.

4.8.6 Motor brake terminal (CN8)

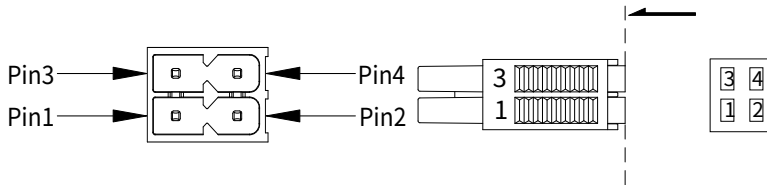

CN7 port function			
Pin	Signal	Function	Remarks
1	24V_BK	Brake external 24V power supply	24V power supply provided by the user
2	COM	Brake external 24V ground	
3	24V_BK	Brake BK+	
4	BK-	Brake BK-	

Brake wiring: The connection of the brake input signal has no polarity, and an example of the standard connection between the brake signal BK and the brake power supply is shown as below:

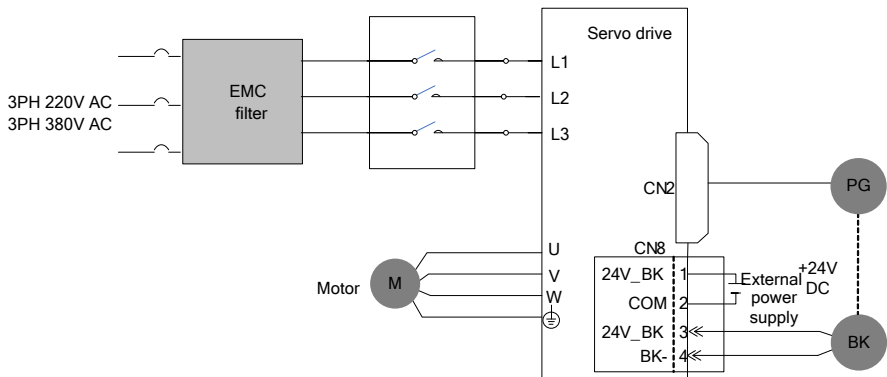

5 Control mode

5.1 Position control mode

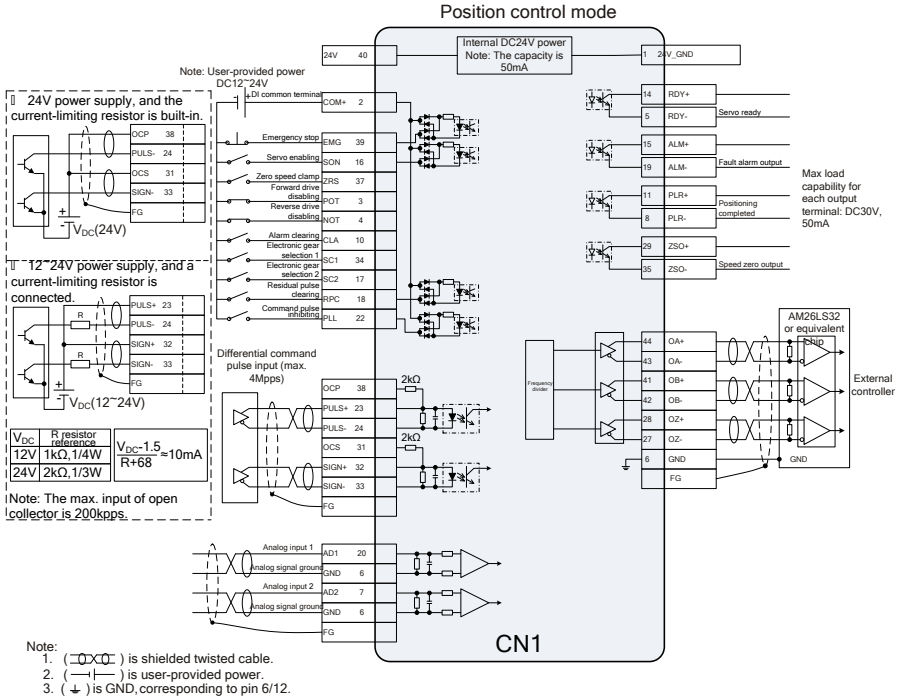

5.2 Speed control mode

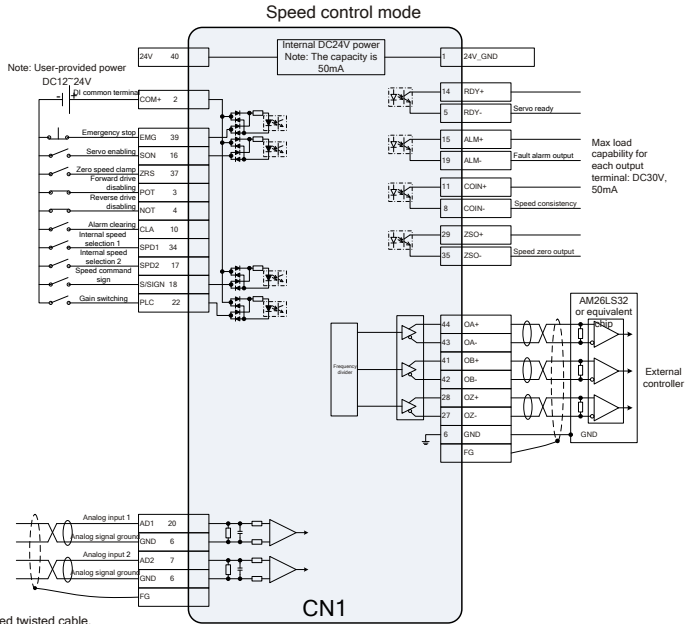

5.3 Torque control mode

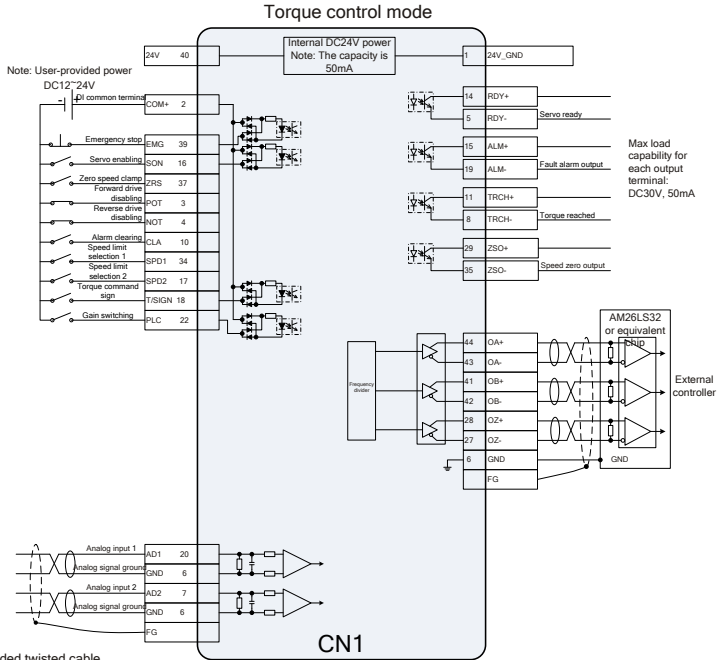

- Note:
1. (—○X○—) is shielded twisted cable.
 2. (—|—) is user-provided power.
 3. (⬇) is GND, corresponding to pin 6/12.

5.4 Bus control mode

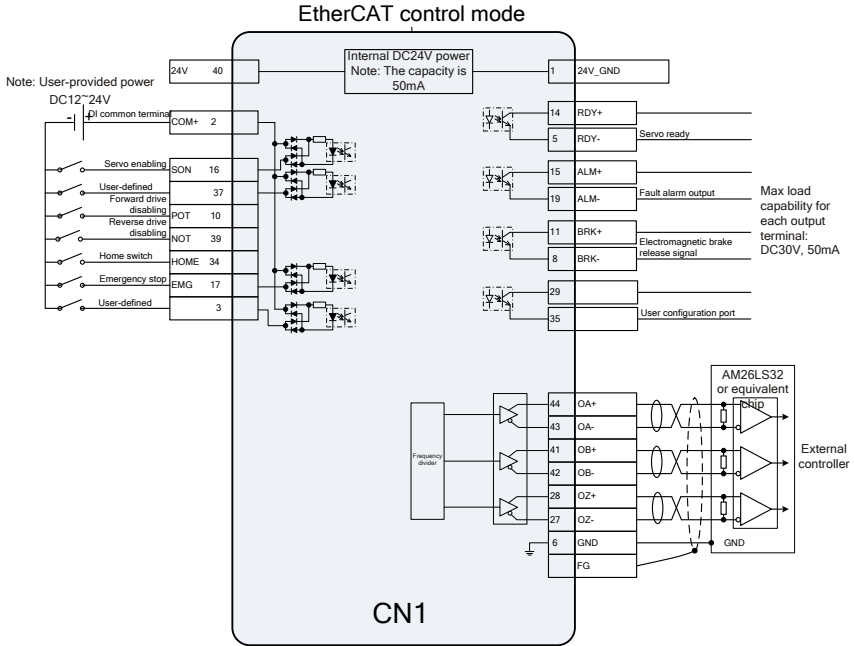

- Note:
1. (—○—○—) is shielded twisted cable.
 2. (—|—|—) is user-provided power.
 3. (⊥) is GND, corresponding to pin 6/12.

6 Commissioning tools

6.1 Keypad

6.1.1 Panel display

6.1.1.1 Display interface

The servo drive panel consists of a 6-digit, 7-segment LED digital tube and keys. Various functions can be realized through the panel operation, such as: displaying the monitoring parameters of the drive, setting parameters and reading status data.

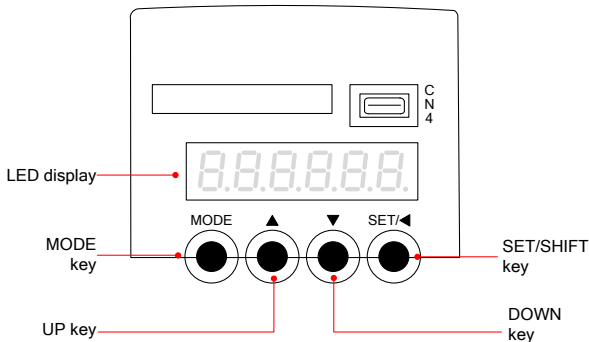





6.1.1.2 Display area

The digital display zone shows a 6-digit LED value, which can display fault alarm codes, monitoring parameters and various status data.

Display	Means	Display	Means	Display	Means	Display	Means
0	0	1	1	2	2	3	3
4	4	5	5	6	6	7	7
8	8	9	9	A	A	b	b
C	C	d	d	E	E	F	F
g	g	h	h	i	i	j	j
k	k	l	l	m	m	n	n
o	o	p	p	q	q	r	r
s	s	t	t	u	u	v	v
w	w	x	x	y	y	z	z
.	.	-	-				

6.1.1.3 Keys

Keys		Function
MODE 	MODE	To switch modes or return to the previous menu level
	UP	Increase or decrease the parameter or function code progressively
	DOWN	Note: The multi-segment parameter can be used to switch high-segment, medium-segment and low-segment values.
SET/◀ 	SET/SHIFT	Press for a long time = SET (about 0.6 seconds): To enter next menu in parameter mode and to confirm the setting of parameter in edit mode. Press for a short time = SHIFT: Change the function code group in parameter mode and cyclically shift the blinking character left in edit mode to modify the position of the parameter bit.

6.1.1.4 Mode switchover

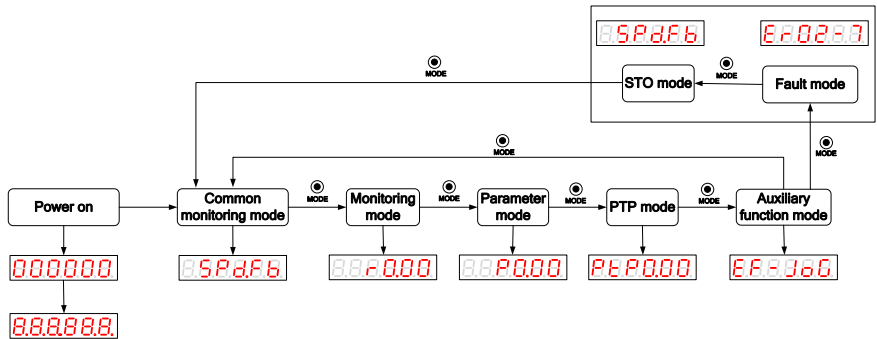

Note:

If the drive is powered on, the screen will display **000000** for 1s, and then display **8.8.8.8.8.8** for 1s, after that, enter into the “General monitoring mode”.

Press **MODE** key to switch **General monitoring mode > Parameters mode > PTP mode > Auxiliary function mode > Fault mode > STO mode** as a cycle mode. If no fault or no STO input, the **fault mode** and **STO mode** can be ignored.

When a new fault occurs, no matter in any mode, it will immediately switch to **Fault mode**, and you can press **MODE** key to switch to other modes. After switching to other modes and no key is pressed

in 20 seconds, it will automatically switch to **Fault mode**.

6.1.1.5 Long parameters (parameters with over 6 digits) setting

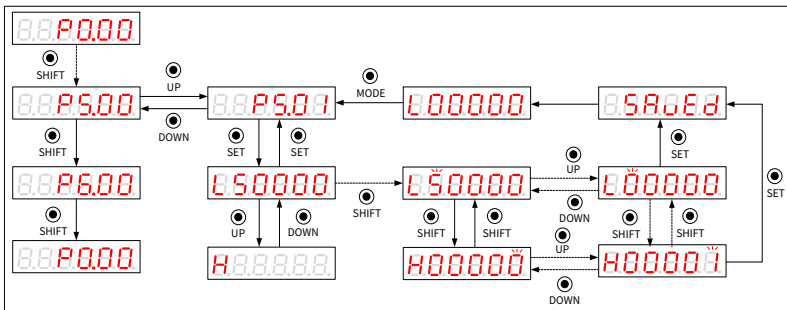

6.1.2 Common monitoring mode

After power on, the interface enters into **General monitoring mode** by default.

The current value will be displayed after the monitoring parameter code is continuously displayed for 2.5s, and you can press the MODE key to return to the parameter code display interface. The monitoring parameters displayed by default can be set via P0.15. For details about definitions of common monitoring parameters, see section A.3 Common monitoring parameter list. The operation example is as follows:

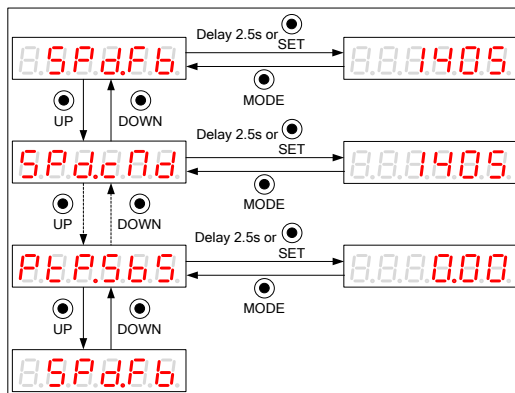

Note:

If no operation is carried out under interfaces other than parameter value display interface, after 20s, it will automatically return to the current common monitoring parameter code display interface in 20 seconds.

Press **UP/DOWN** key to switch common monitoring parameters.

6.1.3 Monitoring mode

After the drive is powered on, press **MODE** to switch to the **Monitoring mode**.

After locating the target parameter, you can press **SET** key to view the current value of the function parameter and press **MODE** key to return to the function code parameter displaying interface. For detail about the meaning of monitoring parameters, see section [A.1.2 State monitoring parameter list](#). The operation schematic diagram is as follows:

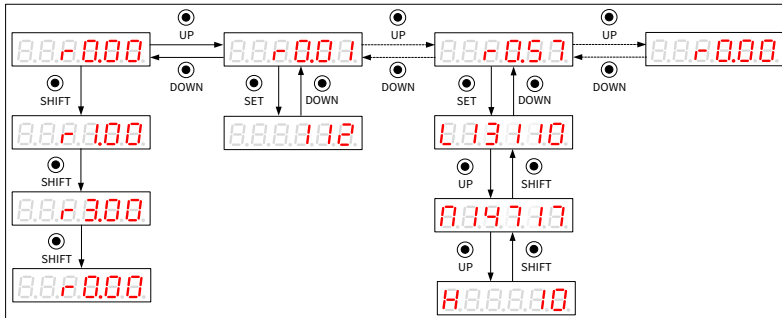

Note:

- If no operation is carried out on the R0-R3 group menu interface, it will automatically return to the current common monitoring parameter interface after 20 seconds.
- Press **SHIFT** key to select the function code group number of the monitoring parameters, press **UP** or **DOWN** key to select the internal parameter number of function codes, and press **UP** or **DOWN** key for a long time to select the parameter number quickly.

6.1.4 Parameter setting mode instruction

After the drive is powered on, press **MODE** key to switch to the **Parameter setting mode**.

After locating the target parameter, you can press **SET** key to enter the function code current parameter value display interface, then press **SHIFT** key to enter the parameter setting interface where the parameter LSB blinks.

After setting is completed, press **SET** key to save the parameters. After finishing, the screen will display **580E8** (for storage parameters and P0.17 is set to 0) or **502E9** (for non-storage parameter or P0.17 is set to 1), and then return to the parameters mode automatically. The operation schematic diagram is as follows:

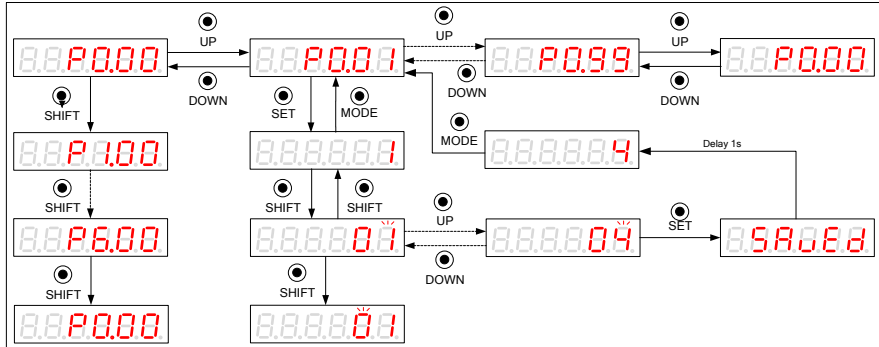

Note:

- Press **SHIFT** key to select the function code parameter group in one-way cycle, and shift the cursor left to select function code parameter setting bit for quick parameter setting.
- Press **UP** or **DOWN** key to select function code parameter number, and press **UP** or **DOWN** key for a long time to select the function code parameter number quickly.

6.1.5 Auxiliary function instruction

6.1.5.1 Auxiliary function menu

After the drive is powered on, press **MODE** to switch to the auxiliary mode.

Press **UP** or **DOWN** key to select auxiliary functions, and the auxiliary function codes are as follows.

Name	Symbol code
Jogging test	E P 0 0 0 0
Restore to default values	E P 0 0 0 0
Program commissioning	E P 0 0 0 0
Analog input 1 zero drift clear	E P 0 0 0 0
Analog input 2 zero drift clear	E P 0 0 0 0
Analog input 3 zero drift clear	E P 0 0 0 0
Inertia identification	E P 0 0 0 0
Absolute value encoder clear	E P 0 0 0 0

Note: The auxiliary functions can be operated only when servo is disabled, otherwise users cannot enter the auxiliary function menu.

6.1.5.2 Operation flowchart of trial jogging

Press **MODE** key to switch to the auxiliary function mode, then press **UP** or **DOWN** key to the **EE-0000** menu.

Press **SET** key to the jogging interface which displays the current speed of the motor.

Press **UP** key, the motor will rotate to the setting speed anticlockwise and stops when releasing the key. Press **DOWN** key, the motor will rotate to the setting speed clockwise

and stops when releasing the key. Press **DOWN** key, the motor will rotate to the setting speed clockwise and stops when releasing the key. The operation schematic diagram is as follows:

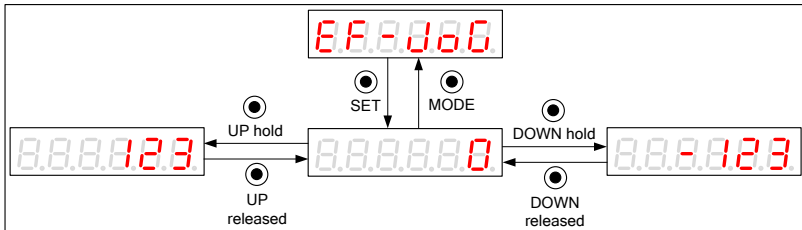

6.1.5.3 Operation flowchart of restoring the factory parameter

Press **MODE** key to switch to the auxiliary function mode, then press **UP** or **DOWN** key to the **EE-288F** menu.

Press **SET** key to enter the default parameter restoring screen, displaying **EE8884**.

Then you can press **SET** to restore to default settings. During the restoring process, the screen displays **EE888E**. When the process ends, the screen displays **EE8884**. The operation schematic diagram is as follows:

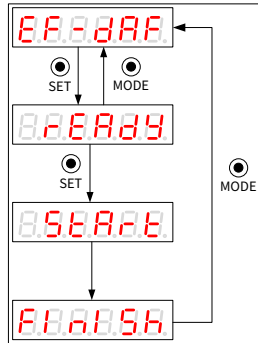

Note: The zero-drift clearing process for analog input 1, 2, and 3 is similar to the factory parameter restoring process.

6.1.5.4 Operation flowchart of program jogging

Press **MODE** key to switch to the auxiliary function mode, then press **UP** or **DOWN** key to the **E.P.A.P** menu.

Press **SET** key to enter the program jogging screen, displaying **P.E.A.D.Y**. On the **P.E.A.D.Y** screen, you can press **SHIFT** to switch between **P.E.A.D.Y** and **S.E.A.P.E** to enable and disable program jogging. The operation schematic diagram is as follows:

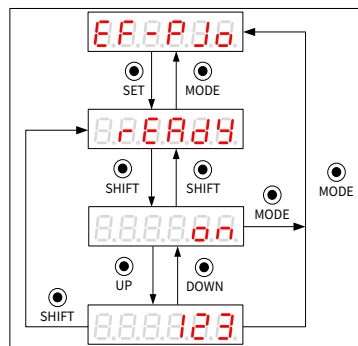

Note:

On the **S.E.A.P.E** screen, you can press **UP** or **DOWN** to start program jogging.

The setting of the **UP** or **DOWN** key is associated with P5.00. If the program starts the motor by jogging and the running direction of the motor is counterclockwise, the **UP** key must be used for starting. If the program starts the motor by jogging and the running direction of the motor is clockwise, the **DOWN** key must be used for starting. After

starting, the interface displays the current speed of the motor.

6.1.5.5 Operation flowchart of inertia identification

Press **MODE** key to switch to the auxiliary function mode, then press **UP** or **DOWN** key to the **ErrEnd** menu.

Press **SET** key to enter the program inertia identification screen, displaying **PrErrd**. Then you can press **SET** to enable inertia identifying. After inertia identifying is complete, the result data such as **0000.23** is displayed about three seconds and then saved automatically. The screen returns to the parameter setting menu automatically after displaying **Saved** about two seconds. The operation schematic diagram is as follows:

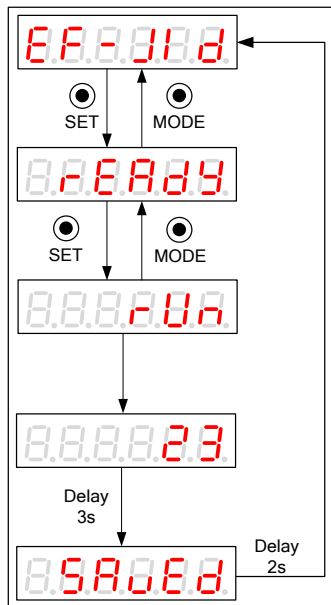

6.1.5.6 Operation flowchart of absolute encoder clearing

If a multi-turn absolute encoder is used, the homing operation for the mechanical system must be performed after the first power-on. Then you can press **MODE** to enter the auxiliary function mode, press **UP** or **DOWN** to enter the **ErrEnd** menu, and press **SET** to enter the absolute encoder clearing menu, which displays **PrErrd**. The operation schematic diagram is as follows:

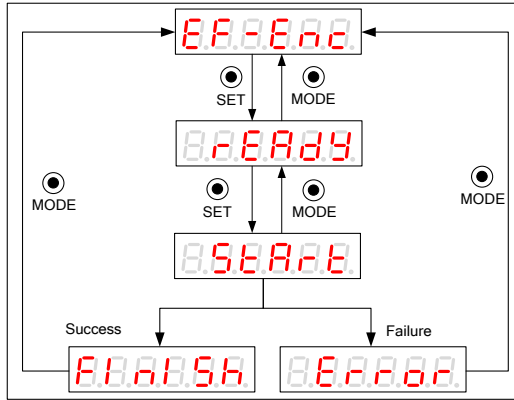

Note: Then you can press **SET** to enable absolute encoder clearing. The screen displays **SEArE**. If the clearing is successful, the screen displays **FLASH**. If the encoder type does not match or the clearing fails, the screen displays **Error**.

6.1.6 Fault mode

6.1.6.1 Displaying fault alarms

If the servo drive runs abnormally, it reports a fault alarm and stops automatically, while the LED panel displays the fault alarm code. For details about fault codes, see section [10.1 Fault codes](#). The fault code schematic diagram is as follows:

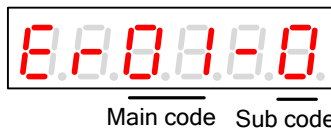

6.1.6.2 Clearing fault alarms

For those faults that can be cleared online, if the fault condition is removed, faults can be cleared by short connecting the digital input terminal (P3.00–P3.09) with COM+. If the drive still has enabling command input, the drive will not be able to clear the fault automatically.

For the fault alarms which cannot be cleared online, it can be cleared after repower on.

Note: You need to set P3.00–P3.09 to 0x004 or 0x104 before performing the shorting configuration.

6.2 PC host controller software

6.2.1 Introduction of host controller software INVT Workshop

INVT Workshop is a PC monitoring and debugging software that comes with the DA200A servo drive, which provides the following features:

- Monitor the servo device.
- Set and monitor function code parameters, and upload and download parameters in batch
- View the modified function codes, compare the default values, follow function codes, and search function coeds
- View and follow state parameters
- View the real-time faults and historical faults
- Display function codes in configuration mode
- Control the start/stop and forward/reverse running of the device
- View oscilloscope curve, save and playback waveform data, operate the waveform by cursor, and simulate waveform data.
- Switch interface color and language.
- Create a function code configuration table.

 **Note:** The software can only monitor one type of product at a time, e.g. if the software monitors a servo drive, it cannot monitor a drive at the same time.

6.2.2 Installation requirements

■ Hardware requirements

CPU	Above P4
Memory	2GB or above
Hard disk	500GB or above
Screen resolution	800×600 or above
Communication interface	USB1.1

■ Software requirements

Operating system	Windows XP, Windows 7, Window10
Excel software	Excel2007, Excel2010 or above

6.2.3 Installation and running

■ Installation

You can visit our official website at www.invt.com, select **Support > Download**, enter the keyword "INVT Workshop" to search and download the installer, and then follow the following steps to install INVT Workshop.

Step 1 Run the **Setup.exe** installer file of INVT Workshop.

Extract the compressed file, double click the **Setup.exe** installer file, and the system will automatically pop up the installation wizard. At this time, select the language (Simplified Chinese and English are supported) first, and Simplified Chinese is selected by default.

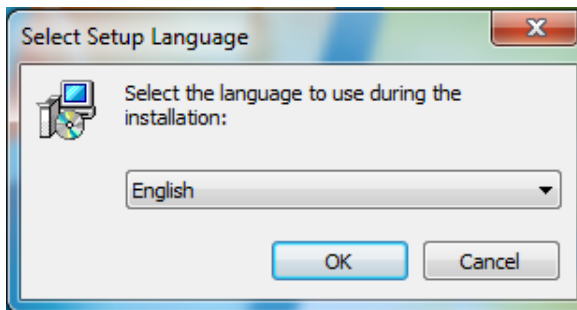

Step 2 Click **OK**, and select the software target location on the **Select Destination Location** interface.

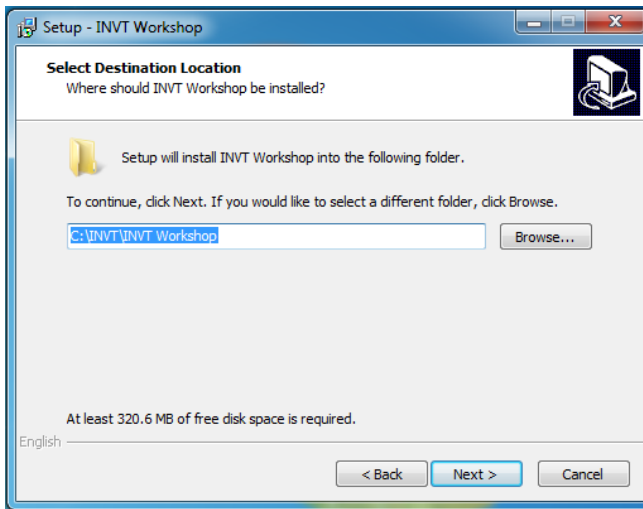

Step 3 Click **Next** and select the following folder on the **Select Start Menu Folder** page.

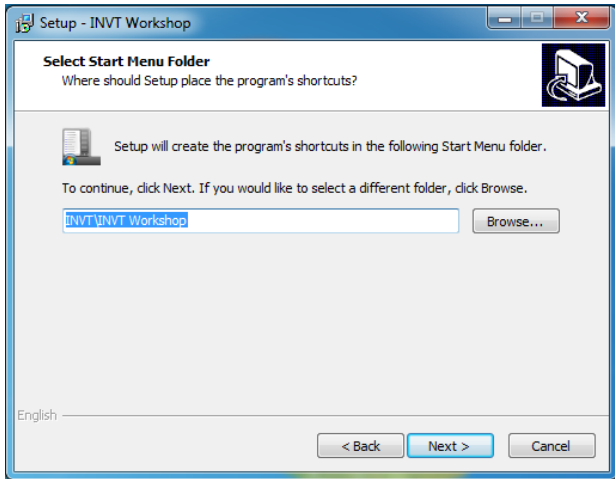

Step 4 Click **Next** and select whether to create a desktop shortcut as needed on the **Select Additional Tasks** page.

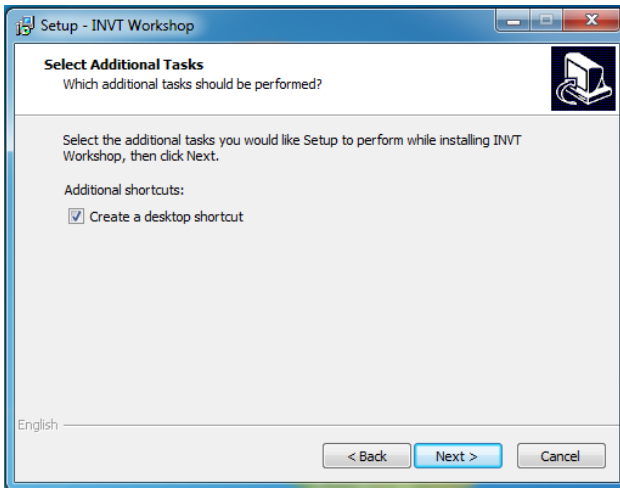

Step 5 Click **Next**, and click **Install** on the **Ready to Install** page.

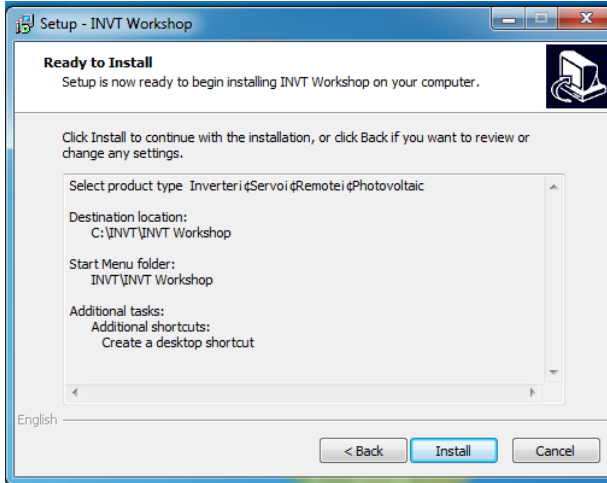

Step 6 When the installation progress bar appears, please wait.

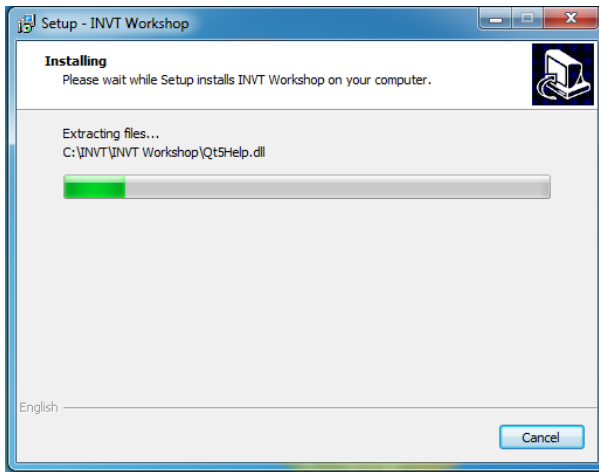

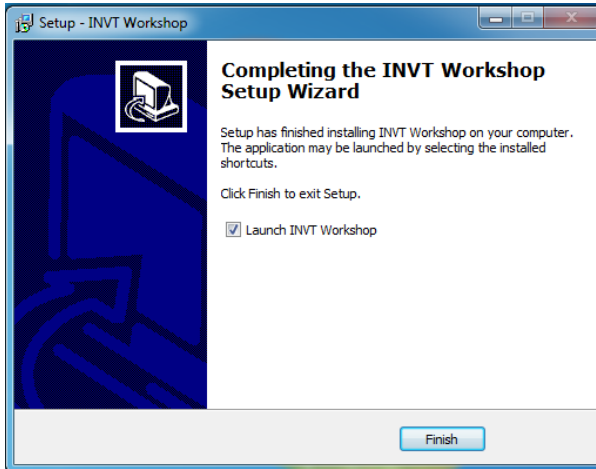

Step 7 After the installation is complete, the installation wizard prompts that the installation is complete, and click **Finish**.



■ **Running**



Step 1 Double-click the desktop shortcut icon , or click shortcut menu  from the start menu.

Step 2 Select **Servo** on the product type selection interface, and click **OK**.

Note: If you select "**Do not show again**", the next time you start the software, the interface will not appear automatically.

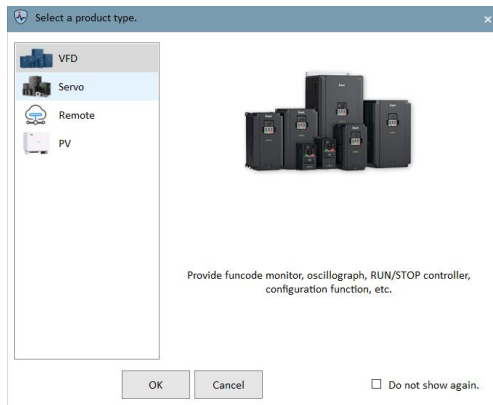

Step 3 The software loading interface appears.



■ **Connection**

The drive is equipped with USB interfaces. After the drive is powered on, you can use a standard USB cable (currently there are three standard interfaces adapted to different models, such as mini USB, micro USB and typeC) to connect the drive to the upper computer, and install the specified USB driver to recognize the USB cable.

The steps to install the USB driver are as follows:

Step 1 Select **Tools > Install USB driver** on the main interface of INVT Workshop.

Step 2 When the driver installation wizard appears, click **Next**.

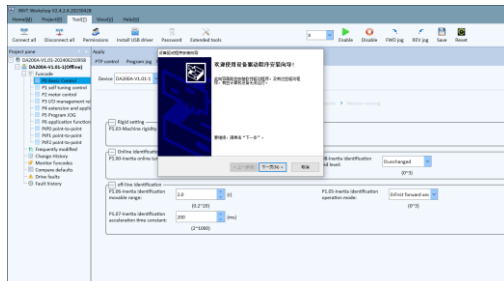

Step 3 When the automatic installation is complete, click **Finish**.



■ **Creating a project**

The procedure is as follows:

Step 1 Select **Project > Create**.

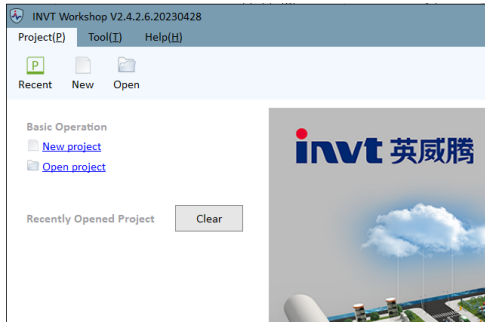

Note: If it is not the first time that you open a project, you will directly enter the last project you entered. When you create a new project or switch projects, you need to close the current project and then enter the new project interface.

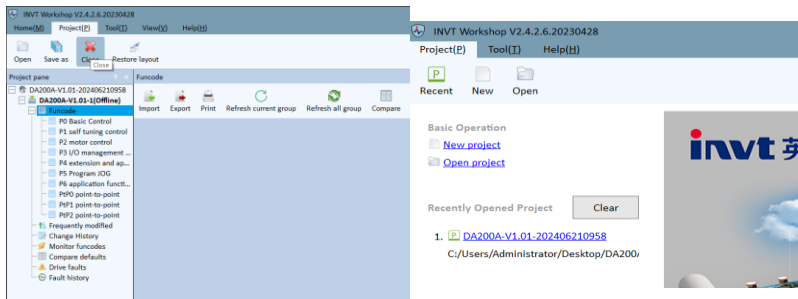

Step 2 Complete the **Device information** and **Communication type** settings on the communication wizard interface.

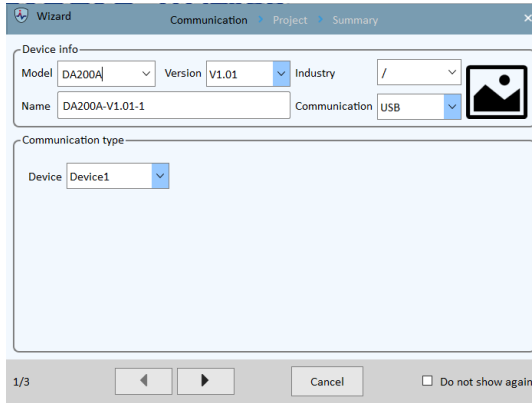

Step 3 Complete the **Name** and **Path** settings on the project wizard interface.

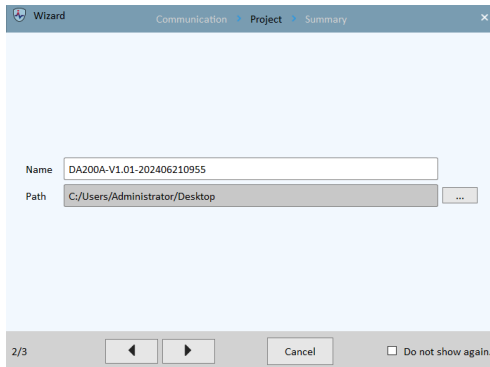

Step 4 Click **OK** to complete the setting.

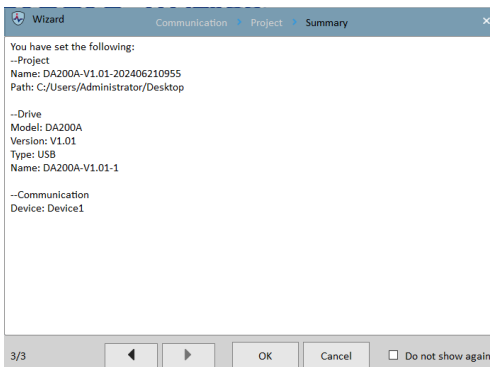

Step 5 The system automatically enters the main interface.

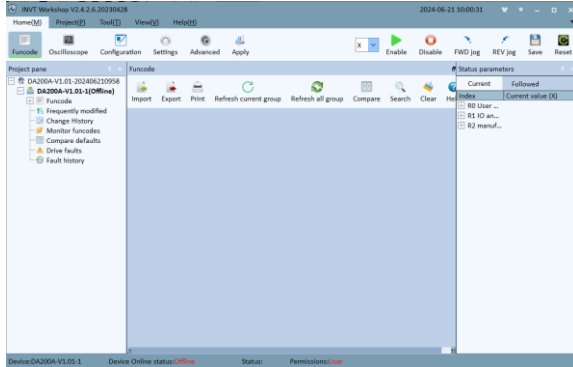

6.2.4 Common functions

This section briefly describes the common functions and interface of INVT Workshop. For more functions, please click **Help** menu to obtain.

Oscilloscope: Detect and save the instantaneous data during the running of the servo drive.

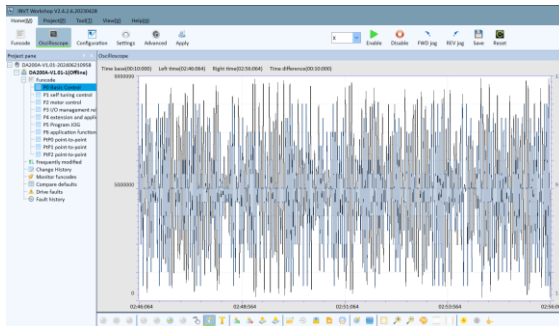

Parameter management: Import and export parameters in batch, compare default values and modify parameters.

Name	Reference	Current value	Save status	Min. value	Max. value	Default	Unit	Lock	Effective	Store	Remarks
P1 self tuning control											
P2 motor control											
P3 UD management on											
P4 extension and apply											
P5 Program JOG											
P6 application function											
P7P1 point-to-point											
P7P2 point-to-point											
P7P3 point-to-point											
P7P4 point-to-point											
P7P5 point-to-point											
P7P6 point-to-point											
P7P7 point-to-point											
P7P8 point-to-point											
P7P9 point-to-point											
P7P10 point-to-point											
P7P11 point-to-point											
P7P12 point-to-point											
P7P13 point-to-point											
P7P14 point-to-point											
P7P15 point-to-point											
P7P16 point-to-point											
P7P17 point-to-point											
P7P18 point-to-point											
P7P19 point-to-point											
P7P20 point-to-point											
P7P21 point-to-point											
P7P22 point-to-point											
P7P23 point-to-point											
P7P24 point-to-point											
P7P25 point-to-point											
P7P26 point-to-point											

Inertia identification: Conduct identification on the load inertia ratio.

Identify Inertia

Device: DA200A-V1.02.1 Auto Refresh

Set parameters Write commands Monitor monitoring

Identify Inertia

P1.05 Machine rigidity setting: 11 (P*%)

P1.06 Inertia identification speed level: (unchanged) (P*%)

P1.07 Inertia identification movable range: 2.0 (0.2~200) (P*%)

P1.08 Inertia identification operation mode: (First forward an... (P*%)

P1.09 Inertia identification acceleration time constant: 200 (0~1000) (ms)

P1.10 Inertia identification deceleration time constant: (2~1000) (ms)

Program JOG: Plan a segment of position instructions to make the motor run repeatedly.

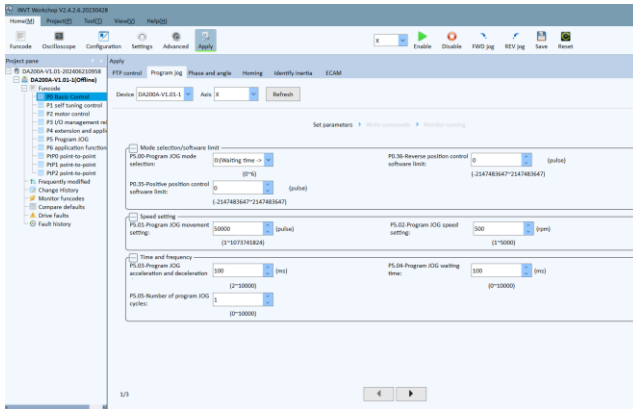

7 Commissioning and running

7.1 Commissioning flowchart

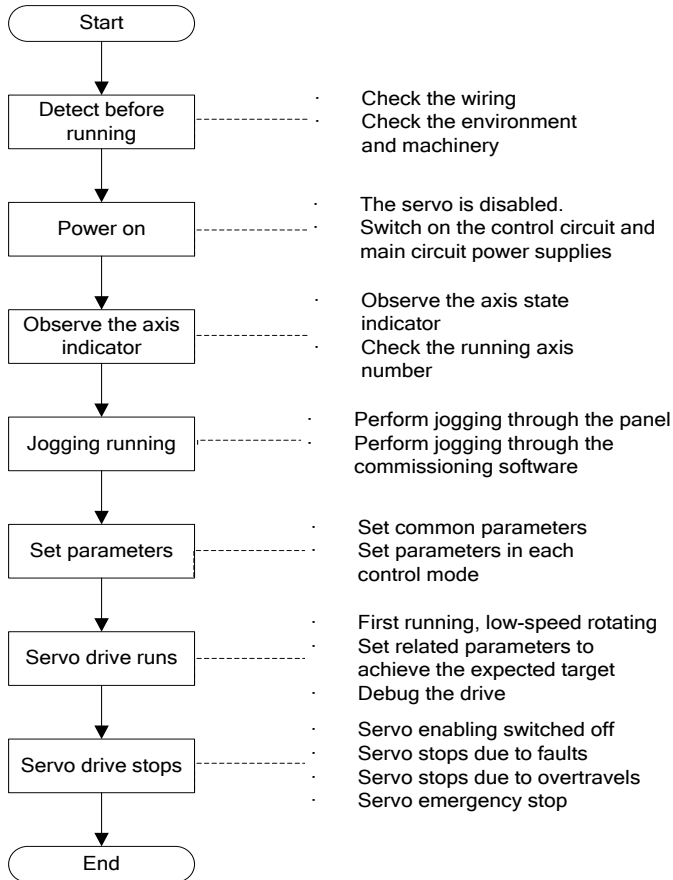

7.2 Connect to the power

Please check following items before power on.

Category	Check item	Complete
Wiring	The power supply terminals (L1, L2, L3, L1C, L2C or R, S and T) of the servo drive are properly connected.	<input type="checkbox"/>
	The output phase (U, V and W) of the servo drive are the same as that of the cables of the servo motor.	<input type="checkbox"/>

Category	Check item	Complete
	There is no short circuit between the output terminals (U, V and W) of the servo drive and the input power terminals (L1, L2, L3 or R, S, T).	<input type="checkbox"/>
	All wiring comply with the standard wiring for each control mode.	<input type="checkbox"/>
	The external terminal (SON) for servo enabling is set to OFF.	<input type="checkbox"/>
	The servo drive and the servo motor are grounded to properly.	<input type="checkbox"/>
	When using an external resistor, for products with small power range, the short connection cable between B2 and B3 has be removed.	<input type="checkbox"/>
	Do not put voltage above DC24V on CN1.	<input type="checkbox"/>
	The cable stress is within the designated range.	<input type="checkbox"/>
Environment	There are no foreign objections, such as metal and other wire lead which can cause short connection of signal and power wires.	<input type="checkbox"/>
Mechanical parts	The servo motor is installed properly, and the shaft and mechanics are connected reliably.	<input type="checkbox"/>
	The servo motor and the machines are available to run.	<input type="checkbox"/>
	Do not run the motor at negative load. Negative load indicates that the direction of the output torque of the motor is contrary to the motor speed direction.	<input type="checkbox"/>

7.3 Jogging

Jogging can check whether the servo drive and the servo motor are intact and conduct preliminary debugging of the system including the servo drive, servo motor and peripheral equipment.

Perform jogging after ensuring that the wiring is correct and there is no fault alarm and abnormal running after power-on.

Note: The motor must be in the non-running state, otherwise it cannot be executed.

Schematic diagram	Step
	<p>Step 1 Press MODE key to switch to the auxiliary function mode.</p> <p>Step 2 Press UP/DOWN key to switch to the E.F.F.U.06 menu. Press UP key, the motor will rotate to the setting speed anticlockwise and stops when releasing the key. Press DOWN key, the motor will rotate to the setting</p>

Schematic diagram	Step
	speed clockwise and stops when releasing the key. Step 3 Press SET key to enter the jogging test interface. The interface displays the current speed of the motor.

Note:

- The load inertia cannot exceed 15 times of the motor inertia. Otherwise it may cause serious mechanical vibration.
- The jog speed can be set via parameter P0.05.
- The accelerating/decelerating time during jogging can be set via parameters P0.54, P0.55 and P0.56, P0.57.

7.4 Running in position control mode

Simple wiring	Step
<p>The diagram illustrates the electrical connections for the servo drive in position control mode. A DC power supply (12-24V) is connected to the COM+ terminal (pin 2) of the CN1 connector. A switch is connected between COM+ and the SON terminal (pin 16). The Upper pulse generator is connected to the PULS+ (pin 23), PULS- (pin 24), SIGN+ (pin 32), and SIGN- (pin 33) terminals. The FG terminal is also shown.</p>	<p>Complete the connection between the servo drive and the servo motor.</p> <p>Step 1 Set P0.03 to 0.</p> <p>Step 2 Confirm the pulse output of the upper controller and adjust P0.23 to ensure that the pulse type of the drive is the same with that of the upper controller.</p> <p>Step 3 Connect the CN1 to the drive and power on. Control the connection between SON and COM-. Then the servo enters into the locking state.</p> <p>Step 4 Send the low frequency pulse command from the upper controller and rotate the motor at low speed.</p> <p>Step 5 Check whether the rotating direction of the motor is as the designated. If not, the direction can be modified by the upper controller or reversed through setting P0.24 to 1.</p> <p>Step 6 Check whether the input pulse number is as the designated. If not, you can set P0.22 or P0.25 and P0.26 to divide or multiply the frequency.</p>

Note: Disconnect the control power supply after the modification of P0.03 and P0.23, and then power on again.

7.5 Running at the speed control mode

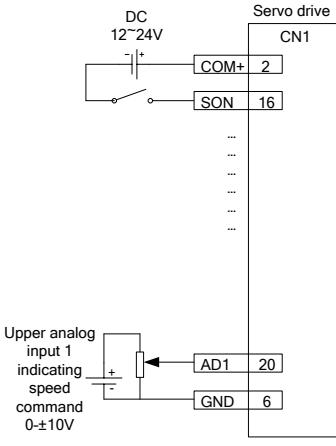
Simple wiring	Step
 <p>DC 12~24V</p> <p>Servo drive CN1</p> <p>COM+ 2</p> <p>SON 16</p> <p>Upper analog input 1 indicating speed command 0±10V</p> <p>AD1 20</p> <p>GND 6</p>	<p>Complete the connection between the servo drive and the servo motor.</p> <p>Step 1 Set P0.03 to 1.</p> <p>Step 2 Set P0.40 to 1.</p> <p>Step 3 Set P3.26 to 3.</p> <p>Step 4 Set P0.42 to the required value.</p> <p>Step 5 Connect the corresponding terminals of CN1.</p> <p>Step 6 Connect the CN1 to the drive and power on. Control the connection between SON and COM+. Then the servo enters into the locking state.</p> <p>Step 7 The motor shaft may rotate at a low speed if there is no upper command voltage. It is necessary to adjust P3.20.</p>

Note: Disconnect the control power supply after the modification of P0.03, and then power on again.

7.6 Running at the torque control mode

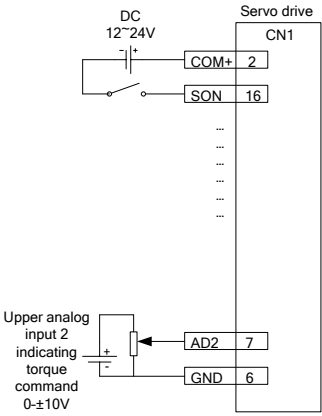
Simple wiring	Step
 <p>DC 12~24V</p> <p>Servo drive CN1</p> <p>COM+ 2</p> <p>SON 16</p> <p>Upper analog input 2 indicating torque command 0±10V</p> <p>AD2 7</p> <p>GND 6</p>	<p>Complete the connection between the servo drive and the servo motor.</p> <p>Step 1 Set P0.03 to 2.</p> <p>Step 2 Set P0.60 to 1.</p> <p>Step 3 Set P0.61 to the required value.</p> <p>Step 4 Set P3.27 to 4.</p> <p>Step 5 Set P0.62 to the required value.</p> <p>Step 6 Connect the corresponding terminals of CN1.</p> <p>Step 7 Connect the CN1 to the drive and power on. Control the connection between SON and COM+. Then the servo enters into the locking state.</p> <p>Step 8 The motor shaft may rotate at a low speed if there is no upper command</p>

Simple wiring	Step
	voltage. It is necessary to adjust P3.23. Step 9 Set P0.46 to the required value.

Note: Disconnect the control power supply after the modification of P0.03, P0.03 and then power on again.

7.7 Adjustment

The servo drive drives the servo motor accurately and quickly by responding to commands from upper computer or internal settings. To achieve this purpose, the servo gain needs to be adjusted appropriately. The servo drive supports both automatic gain adjustment and manual gain adjustment. When the automatic gain adjustment does not achieve the desired effect, manual gain adjustment is performed to optimize the effect.

7.7.1 Inertia identification

The load inertia ratio is an important parameter of the servo system, and a reasonable load inertia ratio facilitates quick commissioning.

The operation flowchart of inertia identification is as follows.

Operation schematic diagram	Step
	<p>Step 1 Press MODE key to switch to the auxiliary function mode.</p> <p>Step 2 Press UP/DOWN key to switch to the E.F.F.F.F.F menu.</p> <p>Step 3 Press SET key to enter the program inertia identification interface. The interface displays E.F.F.F.F.F.</p> <p>Step 4 Press SET to start inertia identification. After inertia identifying is complete, the result data such as E.F.F.F.F.F (example) is displayed about three seconds and then saved automatically. The interface returns to the parameter setting menu automatically after displaying E.F.F.F.F.F about two seconds.</p>

The servo drive provides two methods of inertia identification: Offline and online inertia identification.

Inertia identification method	Premise	Description
Offline	P1.05 (Operation mode of inertia identification) P1.06 (Movable range of inertia identification) P1.07 (ACC/DEC time constant of inertia identification)	<p>The offline mode is available by the auxiliary function EF-JId of the panel operation on the servo drive.</p> <p>Before executing the auxiliary function of EF-JId, set P1.05 according to the operation mode of the motor, set P1.06 according to the rotating cycle and set P1.07 according to the mechanical rigidity. The stronger the mechanical rigidity, the smaller the ACC/DEC time constant.</p> <p>Set P1.05 to 1 or 2. The larger the value of P1.06 is, the smaller the value of P1.07 is, the more correct the identification result.</p> <p>When executing the auxiliary function of EF-JId, please ensure P1.05 and P1.06 meet the needs; otherwise, there may be damage to the machine. You can press MODE key to stop the execution.</p> <p>If the execution EF-JId is finished normally, the identification result will be saved into P1.01 automatically. If there is fault, P1.01 will keep the result before identification. If it reports Er25-7, increase P1.06 or reduce P1.07.</p> <p>If the following occurs onsite.</p> <ul style="list-style-type: none"> • Mechanical rigidity is low. • The load inertia changes too fast. • There are non-linear characteristics such as clearance. • The external disturbance changes too fast. <p>The accuracy of the inertia identification result will be affected.</p>

Inertia identification method	Premise	Description
Online	P1.00 (Tune inertia online) > 0 P1.08 (Speed level of inertia identification) > 0 The ACC time is longer than 20 ms. The continuous acceleration range is more than 150r/min. In 0.3s, the speed can accelerate from 0r/min to 3000 r/min), the identification result will be updated to P1.01 and written into EEPROM in every 30 minutes automatically.	The motor is rotated by commands sent through the host controller communication, and the servo drive automatically calculates the load inertia ratio.

7.7.2 Gain adjustment

There are two kinds of parameters adjustment: Automatic adjustment and manual adjustment.

7.7.2.1 Automatic adjustment

When you choose automatic adjustment for rigidity setting, you need to evaluate the load inertia ratio manually and set the rigidity of the servo system, which has 32 options from 0 to 31. Then different loop gains can be set automatically.

Automatic adjustment features quick adjusting of servo system responsiveness.

Adjust the system rigidity based on the actual situation. The recommended rigidity settings are as follows:

Mechanical structure	Rigidity setting
Large transfer or transmission equipment	0-13
Belt drive mechanism	5-16
Ball screw + belt drive	5-16
Manipulator	15-22
Direct ball screw or rigid body	18-25

A greater rigidity value indicates quicker response, but it increases the possibility to cause noise and vibration. You need to check the mechanical device actions before the setting.

If the setting cannot meet your requirements, use manual adjustment.

7.7.2.2 Manual adjustment

If the servo system encounters vibration or control performance cannot meet requirements, you can adjust speed loop and position loop parameters to eliminate vibration or improve performance.

You can adjust the following parameters manually:

Manual adjustment	Description
Speed loop gain	It determines the response speed of the speed loop. If the mechanical system has no vibration, a greater speed loop gain indicates a quicker response speed.
Speed loop integral time constant	The speed loop contains the integral component, which can respond to minor input. The integral component may delay servo system jobs. A greater time constant indicates slower response, increasing positioning time. If load inertia is heavy or servo system has a great possibility to encounter vibration, this time constant must be great. Otherwise, the servo system may encounter vibration.
Torque command filter	The mechanical system may encounter resonance, which causes sharp vibration noise. At this time, you must use the notch filter to eliminate resonance.
Position loop gain	It determines the servo system responsiveness. A greater position loop gain indicates a quicker response speed, reducing positioning time. If you need to set the gain to a great value, the rigidity and natural frequency of the mechanical system must be high.

Generally, the speed loop gain must be greater than the position loop gain. If the position loop gain is much greater than the speed loop, the system may be overshoot with the function of step signals, therefore deteriorating system performance. System parameters are restricted mutually. If only the position loop gain is increased, the commands output from the position loop may be unstable, which may cause unstable responsiveness of the entire servo system. Perform adjusting in the following sequence:

Set the position loop gain to a small value and increase it to a value as large as possible without causing abnormal noise or vibration.

Decrease the speed loop gain gradually and increase the position loop gain as much as allowed without causing overshooting or vibration.

Decrease the speed loop integral time constant as much as possible without causing vibration since this time constant is determined by positioning time.

Adjust the position loop gain, speed loop gain, and speed loop integral time constant slightly to achieve optimum settings.

7.7.2.3 Typical adjustment

Hereunder we illustrate several typical cases (in each case, only one parameter is changed relative to a case when the parameters are appropriate):

Typical adjustment	Description
Appropriate parameter settings	In this case, parameters are set appropriately, the motor speed is compliant with the position command, the speed is not overshoot, and positioning time is short.
Speed loop integral time constant too small	The servo drive speed loop must respond quickly. If the speed fluctuates, the speed loop integral time constant is too small, which deteriorates the speed loop stability. Therefore, the running is unstable.
Speed loop integral time constant too large	The difference from the case of appropriate parameter settings is not noticeable. The speed loop integral has no significant impact when the speed follows up the position command, but the response time of the speed loop is impacted if the speed loop integral time constant is too large.
Speed loop gain too high	In this case, the motor speed fluctuates. If the speed loop integral time is too short, the similar impact is caused. You must increase both the speed loop gain and the speed loop integral time. Otherwise, the servo system may encounter vibration.
Speed loop gain too low	If the speed loop gain is decreased, the motor speed fluctuates. According to the comparison the case of speed loop gain too large, the fluctuation frequency of the motor speed is lower in this case, which indicates that increasing the speed loop gain improves the system working frequency, control system responsiveness, and anti-interference.
Position loop gain too low	In the servo system, the working frequency of the position loop is lower than that of the speed loop. If the position loop gain is too low, the system cannot counteract the position deviation that is caused during speed responding, which delays the interval at which the motor speed follows up the position command.
Position loop gain too high	In the position servo system, the position loop gain also impacts stability. If the position loop gain is too high, the motor speed fluctuates. According to the comparison with the case of position loop gain too low, the delay with which the motor speed follows up the position command is decreased in this case.
Position loop gain too low	If the position loop gain is too low, the motor speed lags behind the position command noticeably, which not only prolongs the positioning time, but also affects the high accuracy and high response performance of the positioning system.

7.7.3 Gain adjustment of position mode

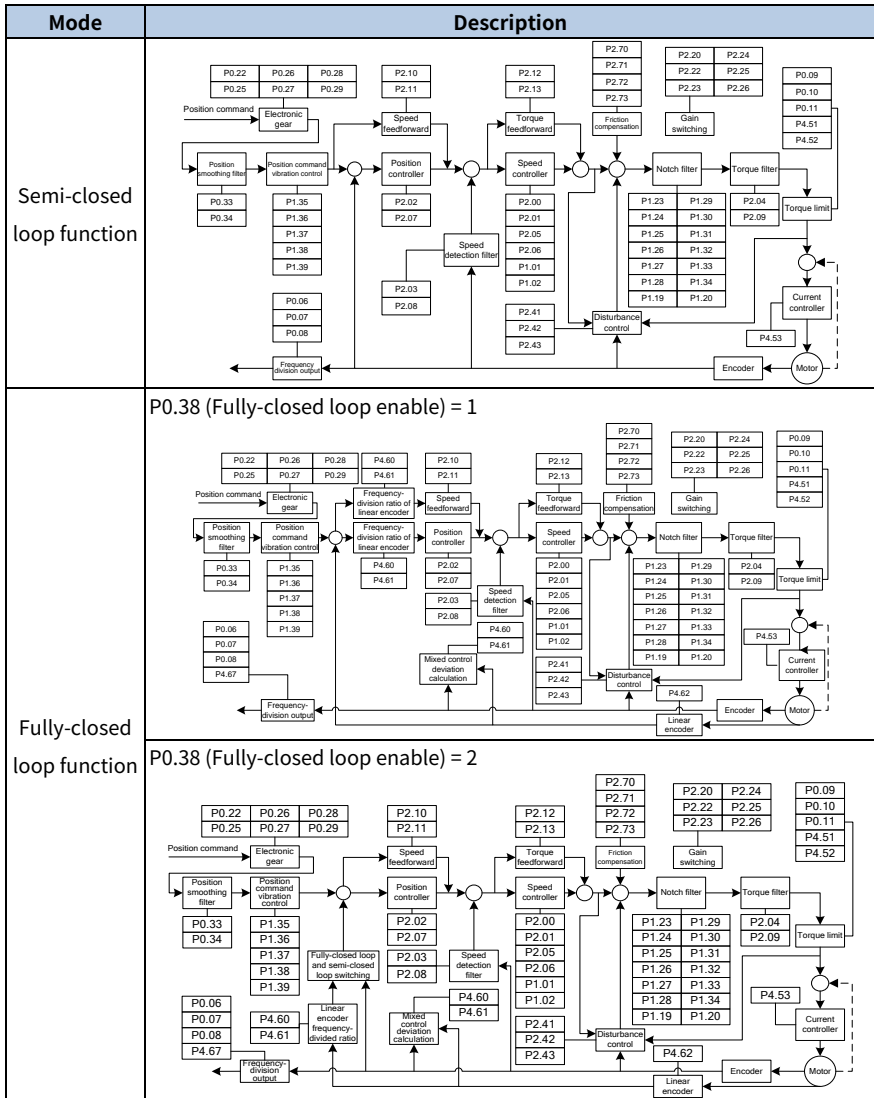

The common procedures for adjusting parameters in position mode are as follows:

Step 1 Restore default settings of the parameter.

Step 2 Adjust the position loop gain.

If the servo motor runs with default settings but the system vibrates with buzzes, decrease the position loop gain (that is, P2.02 or P2.07) or increase it when the system rigidity is low.

Step 3 Adjust the position smoothing filter.

In position control, if the input frequency changes of position pulse commands are noticeable, huge surges may be caused. You need to adjust the P0.33 [Position command smooth filter time] or P0.34 [Position command FIR filter time].

Step 4 Adjust electronic gear.

If the pulse generation device is limited on the pulse sending frequency or the sending frequency does not meet mechanical requirements, you can change the pulse input frequency by adjusting P0.22 [Pulses per motor resolution] or electronic gear ratio parameters (P0.25, P0.26, P0.27, P0.28, and P0.29), so as to meet position control requirements.

Step 5 Adjust the position feed-forward.

If the residual pulses are great or no-deviation tracking is required, you can adjust the speed feed-forward gain parameter P2.10 and speed feed-forward filtering parameter P2.11 to improve position tracking performance. However, if the speed feed-forward gain is too large, the system may vibrate.

Step 6 Set the frequency division for feedback pulse output.

If feedback pulses need to be output, you can set the frequency-division output coefficient parameters P0.06 and P0.07 to change the pulse output frequency.

7.7.4 Gain adjustment of speed mode

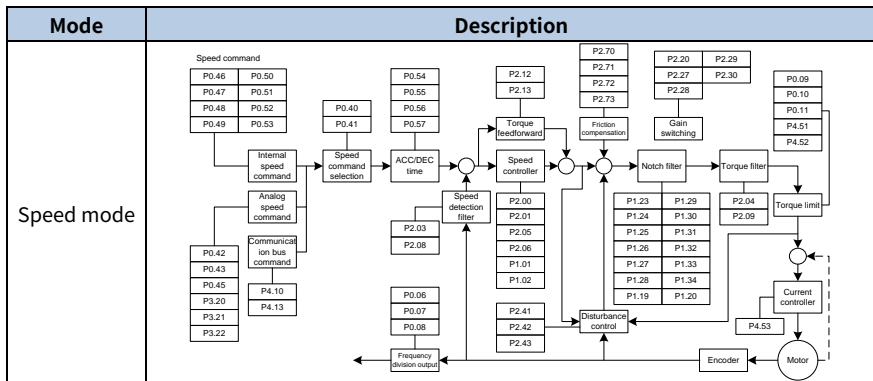

The common procedures for adjusting parameters in speed mode are as follows:

Step 1 Restore default settings of the parameter.

Step 2 Adjust the speed loop gain.

If the servo motor runs with default settings but the system vibrates with buzzes, you need to decrease the speed loop gain (that is, P2.00 or P2.05) or increase it when the system rigidity is low or the speed fluctuates sharply.

Step 3 Adjust speed integral time constant.

If the speed loop gain is increased, you need to increase the speed integral time constant (that is, P2.01 or P2.06) as well. Conversely, if the speed loop gain is decreased, you need to decrease the speed integral time constant as well.

Step 4 Adjust ACC/DEC time.

If the speed in the starting process changes sharply, huge surges or overcurrent may be caused. You need to adjust P0.54 (ACC time) to smooth the ramp-up. Similarly, you can adjust P0.55 (DEC time) to smooth the ramp-down for the stop.

Step 5 Adjust S-curve ACC/DEC time

If the speed change cannot be smoothed by adjusting the ACC or DEC time, you can adjust P0.56 [S-curve ACC time] or P0.57 [S-curve DEC time].

Step 6 Adjust the speed smoothing filter.

If the analog input is a speed command, you can adjust the analog input filter to smooth the speed change.

Step 7 Adjust the torque feed-forward.

If the speed tracking performance is not improved after the parameter adjusting, you can adjust P2.12 [Torque feed-forward gain] and P2.13 [Torque feed-forward filter time] to improve it.

 **Note:** If the torque feed-forward gain is too high, the system may become unstable.

Step 8 Adjust the speed filter.

You can improve speed loop performance by adjusting the torque filter parameters (P2.04 and P2.09) and speed detection filter parameters (P2.03 and P2.08).

Step 9 Adjust the notch filter. See section [7.8 Mechanical resonance suppressing](#).

Step 10 Set the frequency division for feedback pulse output.

If the encoder feedback pulse signal needs to be output, you can set the frequency-division output coefficient parameters P0.06 and P0.07 to change the pulse output frequency.

Step 11 Adjust the disturbance control.

If the load change is noticeable or sudden external disturbance on the torque occurred when the gain settings are small, you can adjust P2.42 [Disturbance observer

compensation gain] and P2.43 [Disturbance observer cut-off frequency] to reduce the impact by external disturbance, so as to improve speed loop performance.

Step 12 Adjust the friction compensation.

If the speed follow-up performance is poor in the process of the motor changing the direction for forward or reverse rotating, you can adjust P2.71 [CCW torque coefficient of friction compensation] and P2.72 [CW torque coefficient of friction compensation] to improve speed loop performance in the process.

7.7.5 Gain adjustment of torque mode

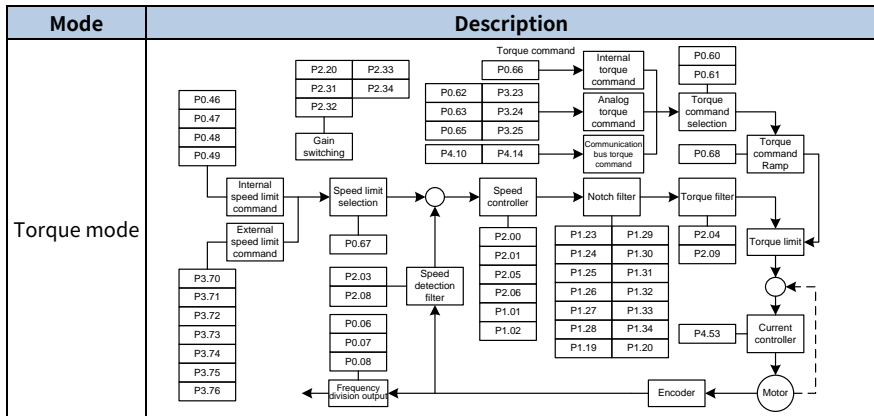

The common procedures for adjusting parameters in torque mode are as follows:

Step 1 Restore default settings of the parameter.

Step 2 Adjust the torque smoothing filter.

If the analog input is a torque command, you can adjust the analog input filter to smooth the torque change.

Step 3 Set the frequency division for feedback pulse output.

If the encoder feedback pulse signal needs to be speed output, you can set the frequency-division output coefficient parameters P0.06 and P0.07 to change the pulse output frequency.

7.8 Mechanical resonance suppressing

The mechanical system has a certain resonant frequency. If a high servo response speed is set when the mechanical rigidity is low, the shaft torsion may cause resonance (including vibration and abnormal noise) near the mechanical resonant frequency. The resonance of the mechanical system can be effectively suppressed by setting the

parameters of the notch filters.

The notch filters achieve the goal of suppressing mechanical resonance by decreasing the gain of certain frequency. You can set notch filter parameters to suppress the resonant frequency, width, and depth, so as for the system to obtain higher gains or reduce vibration.

This servo drive is equipped with four notch filters which can be set by the first notch filter parameter (P1.23, P1.24, P1.25), the second notch filter parameter (P1.26, P1.27, P1.28), the third notch filter parameter (P1.29, P1.30, P1.31) and fourth notch filter parameter (P1.32, P1.33, P1.34). The first and the second notch filter parameters need to be set manually; the third and fourth notch filter parameters can be set by online self-adaptation. The position of notch filter in speed loop is shown in section [7.7.4 Gain adjustment of speed mode](#). The setup of notch filter is shown in the diagram below.

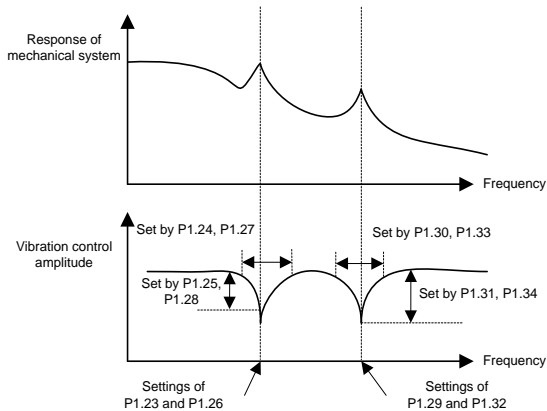

Note: The notch filters are a lagging factor for the servo system. If the center frequency of a notch filter is incorrectly set or the suppression depth is too large, the vibration may be stronger. It is recommended to gradually increase the depth (the parameter setting changes from large to small) until requirements are met.

The relationship between the Q value, width, and depth of a notch filter is as follows:

Q value of the notch filter = Center frequency of the notch wave/Width of the notch wave

The width of the notch filter indicates the frequency difference between the -3dB-dropped power spectrums at the two sides of the center frequency when the depth of the notch filter is 0.

The depth of the notch filter indicates the ratio of input to output. The power spectrum strength is attenuated by $20\log(P1.25\%, P1.28\%, P1.31\%, P1.34\%)$ dB.

7.9 Gain switchover

Gain switching operation is performed through internal data or external signal:

- Control motor vibration if the gain is reduced during stop.
- Shorten tuning and positioning time if the gain is increased during stop.
- Improve command follow-up and speed if the gain is increased during working.
- Control gain switching through external signals based on external state of device.

■ Position control and fully-closed loop control (✓: valid, -: invalid)

Condition setting of gain switching			Parameters setting of position control and fully-closed loop control mode		
P2.22	Switch to the second gain	Figure	Delay time ^{*1}	Level	Lag ^{*2}
			P2.23	P2.24	P2.25
0	First gain fixed	-	-	-	-
1	Second gain fixed	-	-	-	-
2	Switching input with gain	-	-	-	-
3	Large torque command	1	✓	✓ (0.1%)	✓ (0.1%)
4	Large speed command	3	✓	✓ (r/min)	✓ (r/min)
5	Large position deviation	4	✓	✓ ^{*3} (reference unit)	✓ ^{*3} (reference unit)
6	With position command	5	✓	-	-
7	Positioning not finished	6	✓	-	-
8	Large actual speed	3	✓	✓ r/min	✓ (r/min)
9	With position command+actual speed	7	✓	✓ (r/min) ^{*5}	✓ (r/min) ^{*5}

■ Speed control mode

Condition setting of gain switching			Parameters setting of speed control mode		
P2.27	Switch to the second gain	Figure	Delay time ^{*1}	Level	Lag ^{*2}
			P2.28	P2.29	P2.30
0	First gain fixed		-	-	-
1	Second gain fixed		-	-	-
2	Switching input with gain		-	-	-
3	Torque command	1	✓	✓ (0.1%)	✓ (0.1%)

Condition setting of gain switching			Parameters setting of speed control mode		
P2.27	Switch to the second gain	Figure	Delay time ^{*1}	Level	Lag ^{*2}
			P2.28	P2.29	P2.30
4	Speed command variable	2	-	√*4[10(r/min)/s]	√*4[10(r/min)/s]
5	Velocity	3	✓	✓ (r/min)	✓ (r/min)

■ Torque control mode

Condition setting of gain switching			Parameters setting of torque control mode		
P2.31	Switch to the second gain	Figure	Delay time ^{*1}	Level	Lag ^{*2}
			P2.32	P2.33	P2.34
0	First gain fixed		-	-	-
1	Second gain fixed		-	-	-
2	Switching input with gain		-	-	-
3	Torque command	1	✓	✓ (0.1%)	✓ (0.1%)

 **Note:**

*1 Delay time (P2.23, P2.28 and P2.32) is only valid when returning from the second gain to the first gain.

*2 The definition of lag (P2.25, P2.30 and P2.34) is shown as the figure below.

*3 The resolution of the encoder and external linear encoder can be designated in the control mode.

*4 If 10r/min speed changing in 1s, the setting value is 1.

*5 If P2.22=9, the delay time, level and lag have different meaning (see figure 7).

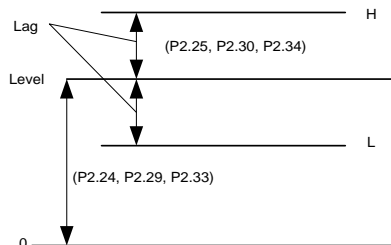

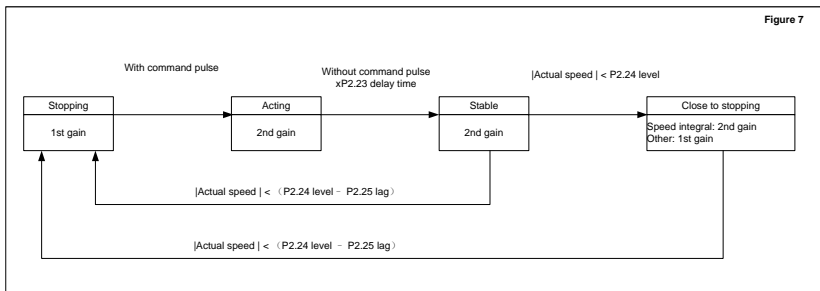
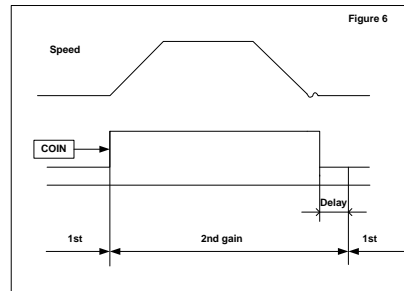
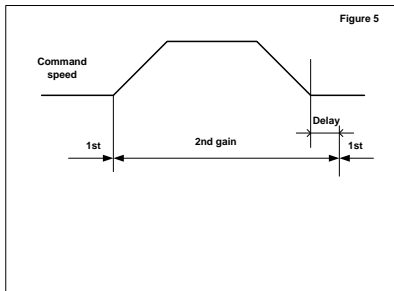
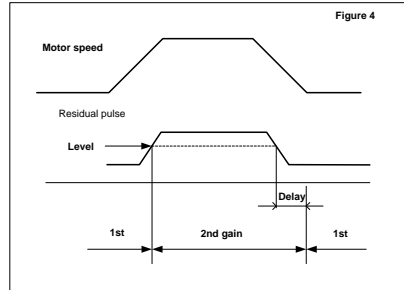
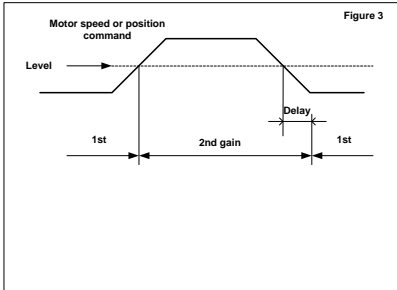
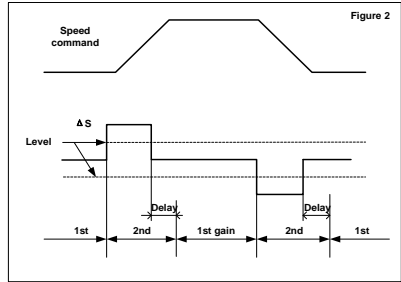
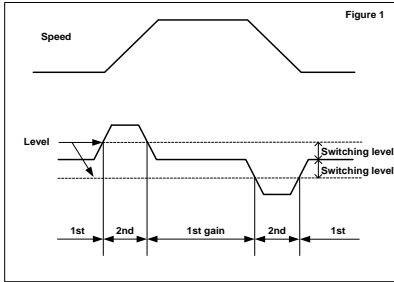

Note: The offset of gain switching sequence caused by lag (P2.25, P2.30, P2.34) is not reflected in above figures.

7.10 Servo enabling

Enable the servo via the external servo enabling terminal (SON) or internal servo enabling parameter (P0.04). See the function description of terminal SON and detailed explanation of parameter P0.04.

When the servo is enabled	
If no alarm occurs	If a servo alarm occurs
The panel will display the default monitoring parameters.	The panel will display ErXX-X and flicker and the servo motor will get into the inertia running state.
The fan starts to run.	
The servo runs according to the current mode. <ul style="list-style-type: none"> • In position mode, if there is no pulse command input, the servo is in locked state. • In the speed mode, the servo motor runs at the given speed. • In the torque mode, if no torque is applied externally, the servo motor accelerates from zero speed to the limit speed. If the external torque is larger than the internal setting one, the servo motor maintains the state of zero speed output. 	

7.11 Servo stop/Stop running

Servo stopping means the servo drive cuts off the output immediately, the motor coasts to stop under the action of inertia until it decelerate to zero speed, and does not keep in locked state. Servo stops running, which means the servo drive outputs reverse torque, so that the motor decelerates to zero speed and, after that, the motor is in a locked state. If the servo drive is in the following conditions, the servo motor will coast to stop or stop normally.

Conditions for stop/stop running	Setting method for stop/stop running	Influence
When the servo enabling terminal (SON) signal is set to OFF Hour, the servo motor will stop.	Select the stopping method through setting P4.30.	This process will not cause regenerative braking.
When a fault alarm occurs, the servo motor will stop. Select the stopping method of		This process will not cause regenerative braking.

Conditions for stop/stop running	Setting method for stop/stop running	Influence
the servo motor when an alarm occurs through setting P4.30. See description of P4.30 for details.		
When the digital input terminal configured as zero speed clamp (ZRS) is set to ON and P0.58 is set to a non-zero value, the servo motor stops running.	When P0.58 is set to 1–3, the motor stops running based on the DEC time set by P0.55 and P0.57 in speed mode, and servo is in locked state after stop; in torque mode, the servo motor stops running immediately.	Such stopping process may cause regenerative braking. If braking overload fault alarm occurred, please connect to proper external braking resistor.
If the travel limit switch block function is invalid (P3.40=0), and digital input terminal signal configured as travel limit (POT/NOT) is set to ON, the servo motor decelerates to stop based on the set value of P0.55 and P0.57, and is in the locked state after stop.		If reverse running command input is generated after motor stops, the motor can run in reverse direction.
If the emergency stop switch block function is invalid (P3.41=0), and the digital input terminal configured as EMG is set to ON, the servo motor will coast to stop.		

 **Note:** If the duration of servo disable signal is too short (less than 500ms), PWM signal may be in off state once the servo is enabled again.

7.12 Timing diagram

7.12.1 Sequence diagram of power-on and servo ON

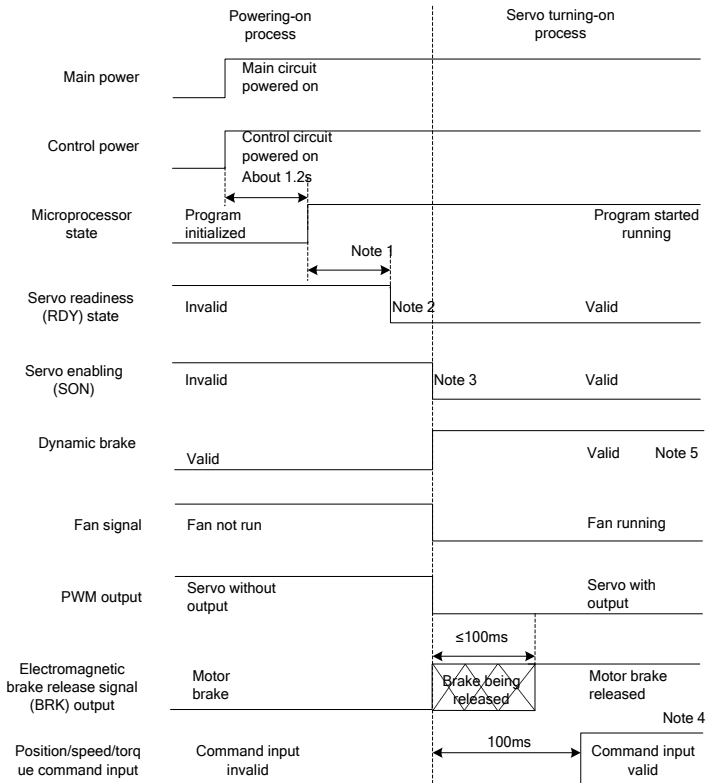

Note 1: The delay time from microprocessor initialization completion to servo readiness output can be set through P4.54.

Note 2: The condition for the RDY output signal electric level to become low is: The servo has no fault and main circuit DC voltage has been established (the voltage is higher than 250V/430V (for 220V/400V series)). If the main circuit DC voltage is less than 170V/310V (for 220V/400V series), the Er13-1 alarm is reported. The time interval from servo readiness to servo enabling can be user controlled.

Note 3: The servo enabling signal can be valid only when the RDY output signal is valid.

Note 4: The actual electrical levels corresponding to valid I/O states can be set through P3.00-P3.15.

Note 5: This dynamic brake timing is available only when the stop mode (P4.30) is dynamic brake acts continuously.

7.12.2 Sequence diagram of power loss during running

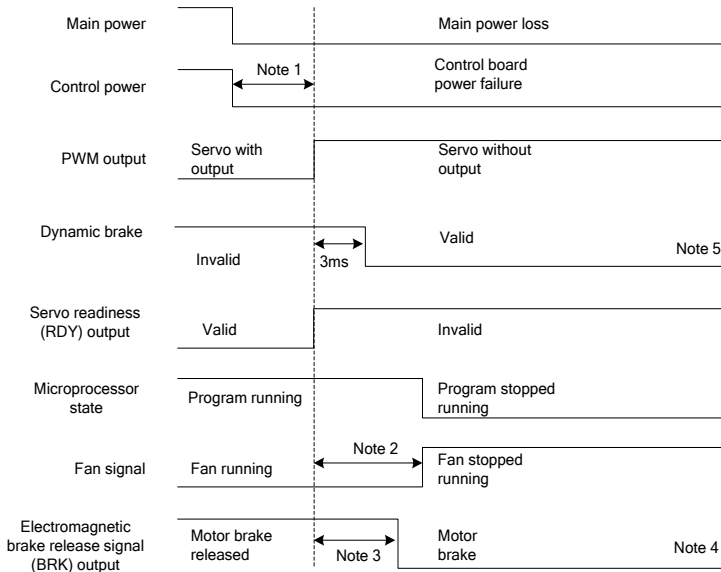

Note 1: If the voltage of the control power is less than 170V/330V(for 220V/400V series), the undervoltage fault will occur and the output level of the servo fault (ALM) will increase.

Note 2: If the drive temperature is less than 45 °C, the fan stops. If the module temperature is higher than 45 °C, the fan stops after the microprocessor stops.

Note 3: The output delay of the electromagnetic brake release signal can be set through P3.57. If the speed slows down under the setting of P3.58 (30r/min by default) during the time specified by P3.57, the BRK signal becomes invalid.

Note 4: The actual electrical levels corresponding to valid I/O states can be set through P3.00-P3.15.

Note 5: This dynamic brake timing is available only when the stop mode (P4.30) is dynamic brake acts continuously.

7.12.3 Servo OFF sequence in a locked state

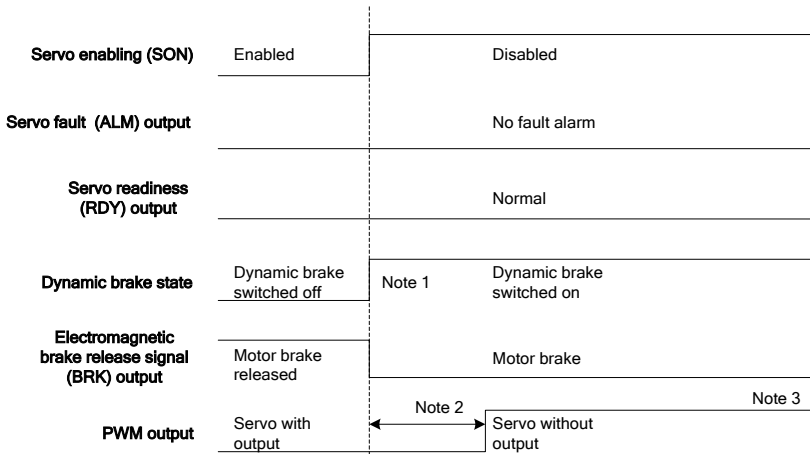

Note 1: Whether to immediately start the dynamic brake can be set through P4.30.

Note 2: The servo locking time after braking can be set through P3.56.

Note 3: The actual electrical levels corresponding to valid I/O states can be set through P3.00-P3.15.

7.12.4 Servo OFF sequence in running state

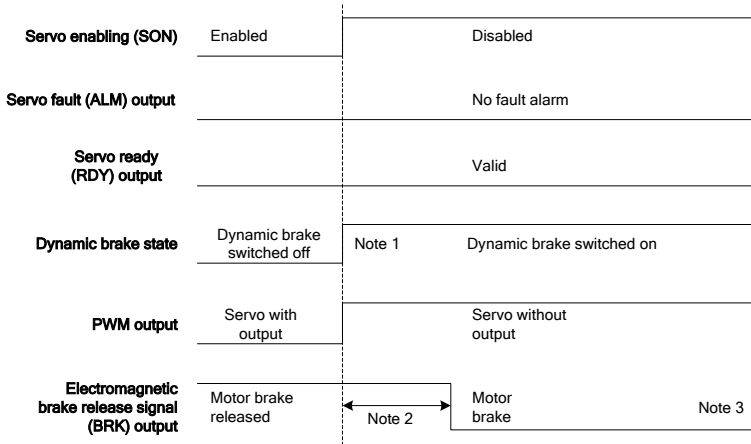

Note 1: Whether to immediately enable the dynamic brake can be set through P4.30.
 Note 2: The output delay of the electromagnetic brake release signal is specified by P3.57. If the speed slows down under the setting of P3.58 during the time specified by P3.57, the BRK signal becomes invalid.
 Note 3: The actual electrical levels corresponding to valid I/O states can be set through P3.00-P3.15.

7.12.5 Sequence of fault alarm

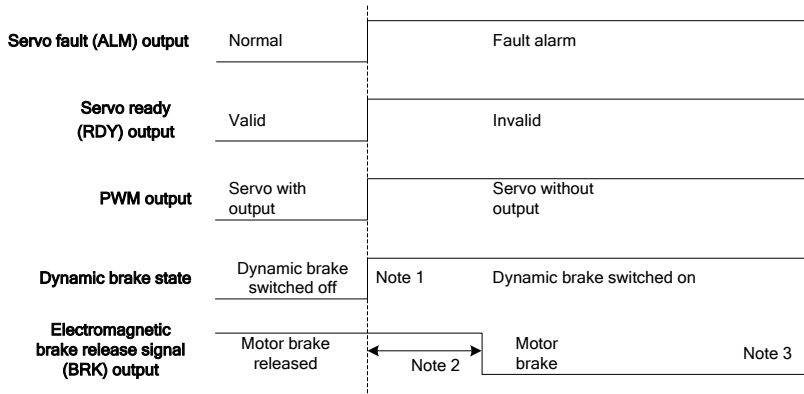

Note 1: Whether to immediately enable the dynamic brake can be set through P4.30.
 Note 2: The output delay of the electromagnetic brake release signal is specified by P3.57. If the speed slows down under the setting (30r/min by default) of P3.58 during the time specified by P3.57, the BRK signal becomes invalid.
 Note 3: The actual electrical levels corresponding to valid I/O states can be set through P3.00-P3.15.

8 Communication

8.1 Communication introduction

DA200A series servo drives are equipped with common communication interfaces such as RS485, CANopen, Ethercat and PN, which can realize various functions by communicating with different devices.

Connection mode	Supported communication interface	Function	
Communication with the upper computer or PLC	RS485	Conduct asynchronous serial half-duplex communication with 31 servo drives simultaneously	The following functions can be implemented through communication: <ul style="list-style-type: none"> ● Read/write the function parameters of the servo drives ● Monitor the operating state of the servo drives ● Form a multi-axis control system
	CANopen	Conduct asynchronous serial half-duplex communication with 127 servo drives simultaneously	
	Ethercat	Conduct synchronous full-duplex communication with up to 65,535 servo drives simultaneously	
Communication with the PC	USB	The servo drive achieves the parameter calibration, state monitoring, data access and other functions.	
	CANopen		
	Ethercat		

8.2 Communication wiring

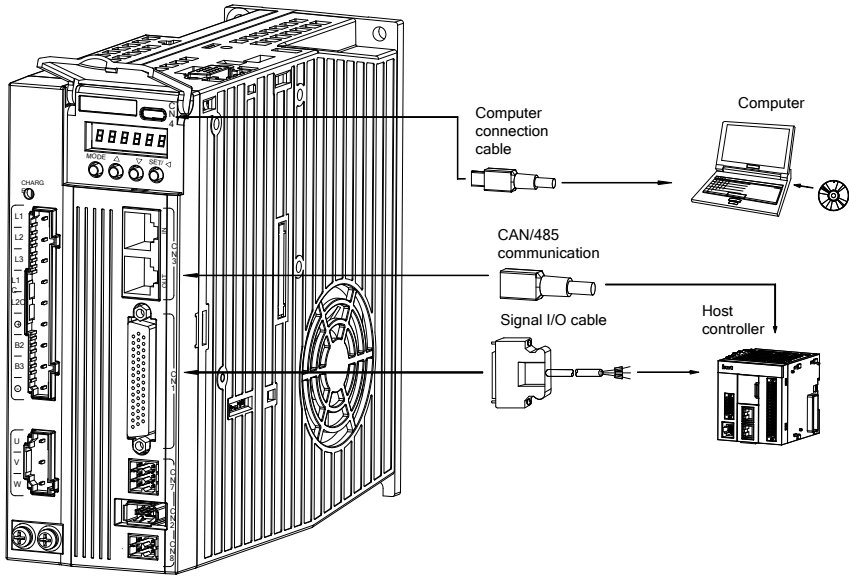
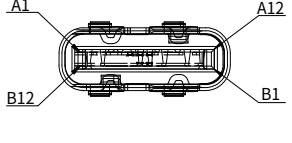

Table8-1 CAN/485-CN3 terminal wiring

CN3 port function table				
	Pin	Name	Function	Remarks
	1	CAN_H	CAN data +	RS485 and CAN use the same interface and each signal has two pins for multiple networking.
	2	CAN_L	CAN data -	
	3	CAN_GND	CAN signal ground	
	4	RS485+	RS485 data +	
	5	RS485-	RS485 data -	
	8	GND	RS485 GND	
	6, 7	-	Unused	

Note: EtherCAT bus-type drive, this port is standard network cable port definition, namely pin 1, 2, 3 and 6 correspond to Tx+, Tx-, Rx+ and Rx- respectively.

Table 8-2 USB-CN4 terminal wiring

CN4 USB port function table				
	Pin	Name	Function	Remarks
	A7, B7	USB-	Data-	Standard type-C interface
	A6, B6	USB+	Data+	
	A1, A12, B1, B12	GND	Signal ground	
A4, B4, A5, B5, A9, B9	-	Unused		

8.3 RS485 communication protocol

8.3.1 Protocol instruction

The Modbus serial communication protocol defines the frame content and format for asynchronous transmission in serial communication. The frame content organized by the master includes: slave address (or broadcast address), execution command, data, and error verification. This includes the format of master polling and broadcast frames, and slave response frames. The response from a slave also adopts the same structure, including action confirmation, returned data, and error verification. If the slave encounters an error when receiving a frame or it cannot complete the action requested by the master, it will generate a fault frame as a response feedback to the master.

DA200A series servo drive uses the asynchronous serial master/slave Modbus communication protocol, which indicates only one device (that is, the master) in the network can establish protocols (called "queries/commands"). The other devices (that is, the slave) can only provide data response to or react according to the "queries/commands" from the master. The master herein indicates the PC, industrial control device, or PLC, while the slave indicates SV-DA200 series servo drive or other control devices with the same communication protocol. The master can communicate with any single slave or broadcast with all slaves. For a separate access "query/command" from the master, a slave needs to return a response. For broadcast information, a slave does not need to return a response.

8.3.2 Communication frame structure

Modbus supports the RTU transmission mode only. You can set the serial communication parameters (including the baud rate and check method).

In an RTU message frame, each 8-bit byte consists of two 4-bit hexadecimal characters.

Table 8-1 RTU message frame

Start bit	Device address	Command	Data	CRC	Stop bit
T1-T2-T3-T4	8bit	8bit	n * 8 bits	16bit	T1-T2-T3-T4

In this mode, each message must be preceded by a time gap with a minimum length of 3.5 characters. During the transmission, the network device continuously detects the network bus even within the time gap. When the first domain (or address domain) is received, the corresponding device decodes the subsequent transmission characters. The message ends only when there is a time gap with a minimum length of 3.5 characters.

An entire RTU message frame must be transmitted as a continuous flow. If a receiver detects a time gap with a minimum length of 1.5 characters before the frame ends, the receiver refreshes the incomplete message and assumes that the next byte is the address domain of a new message. Similarly, if a new message follows the previous message within the time gap with a length of less than 3.5 characters, the receivers considers the new message as the continuity to the previous message. If either of the case occurs, a CRC error message is generated and sent back to the sender.

8.3.3 Command code and communication data description

8.3.3.1 Command code: 03H

Function: read N words (can read no more than 16 words continuously).

For example, the servo drive with the salve address of 01H, if its starting address is 03F2H, read 2 words continuously, and then the structure of the frame is:

Table 8-3 Master command message

START	T1-T2-T3-T4 (transmission time of 3.5 bytes)
ADDR	01H
CMD	03H
MSB of read start address	03H
LSB of read start address	F2H
MSB of data count (in word)	00H
LSB of data count (in word)	02H
CRC CHK LSB	65H
CRC CHK MSB	BCH
END	T1-T2-T3-T4 (transmission time of 3.5 bytes)

Table 8-4 Slave response message

START	T1-T2-T3-T4 (transmission time of 3.5 bytes)
-------	--

ADDR	01H
CMD	03H
Number of bytes	04H
Content MSB of the starting address 03F2H	00H
Content LSB of the starting address 03F2H	C8H
Content MSB of the second address 03F3H	00H
Content LSB of the second address 03F3H	00H
CRC CHK LSB	7BH
CRC CHK MSB	CDH
END	T1-T2-T3-T4 (transmission time of 3.5 bytes)

8.3.3.2 Command code: 10H

Function: write N words ($N \geq 2$)

For example, write 300 (000012CH) into address 03F2H of the servo drive with the slave address 01H. The frame structure is as follows.

Table 8-5 Master command message

START	T1-T2-T3-T4 (transmission time of 3.5 bytes)
ADDR	01H
CMD	10H
MSB of data writing address	03H
LSB of data writing address	F2H
MSB of data count (in word)	00H
LSB of data count (in word)	02H
Number of bytes	04H
MSB of the first word in data content	01H
LSB of the first word in data content	2CH
MSB of the second word in data content	00H
LSB of the second word in data content	00H
CRC CHK LSB	A9H
CRC CHK MSB	F7H
END	T1-T2-T3-T4 (transmission time of 3.5 bytes)

Table 8-6 Slave response message

START	T1-T2-T3-T4 (transmission time of 3.5 bytes)
ADDR	01H
CMD	10H
MSB of data writing starting address	03H
LSB of data writing starting address	F2H

MSB of data count (in word)	00H
LSB of data count (in word)	02H
CRC CHK LSB	E0H
CRC CHK MSB	7FH
END	T1-T2-T3-T4 (transmission time of 3.5 bytes)

8.3.4 Communication frame error check methods

The error check of a frame includes two parts, namely, bit check on individual bytes (that is, odd/even check using the check bit in the character frame), and entire data check (CRC or LRC).

8.3.4.1 Bit check on individual bytes

You can select the bit check mode as required, or you can choose not to perform the check, which will affect the check bit setting of each byte.

Definition of even check: Before the data is transmitted, an even check bit is added to indicate whether the number of "1" in the to-be-transmitted data is odd or even. If it is even, the check bit is set to "0"; and if it is odd, the check bit is set to "1".

Definition of odd check: Before the data is transmitted, an odd check bit is added to indicate whether the number of "1" in the to-be-transmitted data is odd or even. If it is odd, the check bit is set to "0", and if it is even, the check bit is set to "1".

For example, the data bits to be sent are "11001110", include five "1". If the even check is applied, the even check bit is set to "1"; and if the odd check is applied, the odd check bit is set to "0". During the transmission of the data, the odd/even check bit is calculated and placed in the check bit of the frame. The receiving device performs the odd/even check after receiving the data. If it finds that the odd/even parity of the data is inconsistent with the preset information, it determines that a communication error occurs.

8.3.4.2 CRC

A frame in the RTU format includes an error detection domain based on the CRC calculation. The CRC domain checks all the content of the frame. The CRC domain consists of two bytes, including 16 binary bits. It is calculated by the transmitter and added to the frame. The receiver calculates the CRC of the received frame, and compares the result with the value in the received CRC domain. If the two CRC values are not equal to each other, errors occur in the transmission.

During CRC, 0xFFFF is stored first, and then a process is invoked to process a minimum of 6 contiguous bytes in the frame based on the content in the current register. CRC is valid only for the 8-bit data in each character. It is invalid for the start, stop, and check bits.

During the generation of the CRC values, the "exclusive or" (XOR) operation is performed

on the each 8-bit character and the content in the register. The result is placed in the bits from the least significant bit (LSB) to the most significant bit (MSB), and 0 is placed in the MSB. Then, LSB is detected. If LSB is 1, the XOR operation is performed on the current value in the register and the preset value. If LSB is 0, no operation is performed. This process is repeated 8 times. After the last bit (8th bit) is detected and processed, the XOR operation is performed on the next 8-bit byte and the current content in the register. The final values in the register are the CRC values obtained after operations are performed on all the bytes in the frame.

The calculation adopts the international standard CRC check rule. You can refer to the related standard CRC algorithm to compile the CRC calculation program as required.

8.3.5 Error message response

When returning a response, the slave uses a function code domain and fault address to indicate whether it is a normal response (no error) or exception response (an error occurs). In a normal response, the slave returns the corresponding function code and data address or sub-function code. In an exception response, the slave returns a code that is equal to a normal code, but the first bit is logic 1.

For example, if the master sends a request message to a slave for reading a group of function code address data, the following code is generated:

0 0 0 0 0 1 1 (03H in the hexadecimal form)

In a normal response, the slave returns the same function code. In an exception response, the slave returns the following code:

1 0 0 0 0 1 1 (83H in the hexadecimal form)

In addition to the modification of the code, the slave returns a byte of exception code that describes the cause of the exception.

After receiving the exception response, the typical processing of the master is to send the request message again or modify the command based on the fault information.

Table 8-7 Error code definition

Modbus exception codes		
Code	Name	Meaning
01H	Invalid function	The function code received by the upper computer is not allowed to be executed. The possible causes are as follows:☒ <ul style="list-style-type: none"> • The function code is applicable only on new devices and is not implemented on this device.☒ • The slave is in faulty state when processing this request.
02H	Invalid data address	For the drive, the data address in the request of the host controller is not allowed. In particular, the combination of the

Modbus exception codes		
Code	Name	Meaning
		register address and the number of the to-be-sent bytes is invalid.
03H	Invalid data value	The data value received is beyond the range of address parameters, leading the parameter modification invalid.
11H	Check error	In the frame message sent by the upper computer, if the CRC check bit of RTU format or the LRC check bit of ASCII format is different from the check number calculated by the lower device, check error will be reported.

8.4 CANopen communication protocol

8.4.1 CANopen protocol description

CANopen is a high-layer communication protocol structured over the Control Area Network (CAN). It includes the communication profiles and device profiles for embedded systems. It is also an onsite bus widely used in industrial control. Common CANopen devices and communication profiles are defined in CAN in Automation (CiA) draft standard 301. Based on CiA 301, other profiles are developed for special devices, such as CiA 402 for motion control.

8.4.2 CANopen hardware configuration

For pin definitions and function descriptions of the CAN communication terminal CN3, see section [8.2 Communication wiring](#).

Various baud rates, corresponding max. transmission lengths and communication cable diameters are shown in the following table.

Communication baud rate (bit/s)	Communication length (m)	Cable diameter (mm ²)
1M	25	0.205
500k (default)	95	0.34
100k	560	0.5
50k	1000	0.75

Note:

- The CANL and CANH pins of all slaves can be directly connected in serial model, but not star model.
- A 120 Ω terminal resistor must be connected between the master and final node of the slave.

- Shielded twisted pairs are recommended as CAN connection cables for anti-interference.
- A longer connection cable indicates a higher requirement on CAN chip drive ability.

8.4.3 CANopen software configuration

Configure following three parameters before the application of CANopen:

1. Set P0.03 through LED panel or ServoPlover software to 7 [CANopen mode].
2. Set **P4.02** through LED panel or ServoPlover software [CAN Baud rate]. (0: 1Mbps; 1: 500kbps; 2: 250kbps; 3: 125kbps; 4: 50kbps; 5: 20kbps).
3. Set P4.05 through LED panel or ServoPlover software (range:1-127).

Note:

- Above three parameters are valid after restarting, so it is necessary to repower again or reset the drive.
- The node number of the slave cannot be the same as the node number of the master and other slaves (CNC or PLC).
- Synchronous signal is generated by the master or be configured by the slave. The unit of synchronous communication cycle is 1us and the minimum unit of SV-DA200 is 1000 μs (1ms).
- 0x1017 parameters is needed to be configured when the master needs the slave to send a heartbeat message. The unit is 1ms.
- The drive will shut down automatically to ensure safety when CANopen state machine exits from OP state.

8.4.4 CANopen functions

As a standard slave of CANopen, DA200A servo drive supports some parameters of 301 standard protocol and 402 dynamic control protocol.

The basic CANopen protocols supported include NMT, SYNC, SDO, PDO, and EMCY.

The predefined connection set defines four Receive-PDOs, four Transmit-PDOs, one SDO (occupying two CAN-IDs), one emergency object, and one Node-Error-Control ID. The servo drive also supports the NMT-Module-Control service that needs no confirmation and broadcast of SYNC objects.

Table 8-8 CiA 402 protocol parameters supported by the servo drive

Index	Object type	Name	Data Type	Permission	Mappable
6040 _n	VAR	Control word	UNSIGNED16	RW	Y

Index	Object type	Name	Data Type	Permission	Mappable
6041 _h	VAR	Status word	UNSIGNED16	RO	Y
6042 _h	VAR	vl target velocity	INTEGER16	RW	Y
6043 _h	VAR	vl velocity demand	INTEGER16	RO	Y
6044 _h	VAR	vl control effort	INTEGER16	RO	Y
6046 _h	ARRAY	vl velocity min max amount	UNSIGNED32	RW	Y
6047 _h	ARRAY	vl velocity min max	UNSIGNED32	RW	Y
6048 _h	RECORD	vl velocity acceleration	UNSIGNED32	RW	Y
6049 _h	RECORD	vl velocity deceleration	UNSIGNED32	RW	Y
6060 _h	VAR	Mode of operation	INTEGER8	RW	Y
6061 _h	VAR	Mode of operation display	INTEGER8	RO	Y
6062 _h	VAR	Position demand value	INTEGER32	RO	Y
6063 _h	VAR	Position actual value*	INTEGER32	RO	Y
6064 _h	VAR	Position actual value	INTEGER32	RO	Y
6065 _h	VAR	Following error window	UNSIGNED32	RW	Y
6066 _h	VAR	Following error time out	UNSIGNED16	RW	Y
6067 _h	VAR	Position window	UNSIGNED32	RW	Y
6069 _h	VAR	Velocity sensor actual value	INTEGER32	RO	Y
606B _h	VAR	Velocity demand value	INTEGER32	RO	Y
606C _h	VAR	Velocity actual value	INTEGER32	RO	Y
606D _h	VAR	Velocity window	UNSIGNED16	RW	Y
606F _h	VAR	Velocity threshold	UNSIGNED16	RW	Y
6071 _h	VAR	Target torque	INTEGER16	RW	Y
6072 _h	VAR	Max torque	UNSIGNED16	RW	Y
6073 _h	VAR	Max current	UNSIGNED16	RO	Y
6074 _h	VAR	Torque demand value	INTEGER16	RO	Y
6075 _h	VAR	Motor rated current	UNSIGNED32	RO	Y
6076 _h	VAR	Motor rated torque	UNSIGNED32	RO	Y
6077 _h	VAR	Torque actual value	INTEGER16	RO	Y
6078 _h	VAR	Current actual value	INTEGER16	RO	Y
6079 _h	VAR	DC link circuit voltage	UNSIGNED32	RO	Y
607A _h	VAR	Target position	INTEGER32	RW	Y
607C _h	VAR	Home offset	INTEGER32	RW	Y
607D _h	ARRAY	Software position limit	INTEGER32	RW	Y
6080 _h	VAR	Max motor speed	UNSIGNED32	RW	Y
6081 _h	VAR	Profile velocity	UNSIGNED32	RW	Y
6083 _h	VAR	Profile acceleration	UNSIGNED32	RW	Y

Index	Object type	Name	Data Type	Permission	Mappable
6084 _h	VAR	Profile deceleration	UNSIGNED32	RW	Y
6085 _h	VAR	Quick stop deceleration	UNSIGNED32	RW	Y
6086 _h	VAR	Motion profile type	INTEGER16	RO	Y
6087 _h	VAR	Torque slope	UNSIGNED32	RW	Y
6088 _h	VAR	Torque profile type	INTEGER16	RO	Y
6093 _h	ARRAY	Position factor	UNSIGNED32	RW	Y
6098 _h	VAR	Homing method	INTEGER8	RW	Y
6099 _h	ARRAY	Homing speeds	UNSIGNED32	RW	Y
60C0 _h	VAR	Interpolation sub mode select	INTEGER16	RO	Y
60C1 _h	ARRAY	Interpolation data record	INTEGER32	RW	Y
60C2 _h	RECORD	Interpolation time period	INTEGER8	RW	Y
60F4 _h	VAR	Following error actual value	INTEGER32	RO	Y
60F8 _h	VAR	Max slippage	INTEGER32	RW	Y
60FA _h	VAR	Control effort	INTEGER32	RO	Y
60FC _h	VAR	Position demand value*	INTEGER32	RO	Y
60FD _h	VAR	Digital inputs	UNSIGNED32	RO	Y
60FE _h	ARRAY	Digital outputs	UNSIGNED32	RO	Y
60FF _h	VAR	Target velocity	INTEGER32	RW	Y

Table 8-9 CANopen fault codes

Display	Fault name	32-bit fault code (16-bit error code + 16-bit additional information)
Er01-0	IGBT fault	2320-0100h
Er01-1	Braking pipe fault (7.5kW and above models)	7110-0101h
Er02-0	Encoder fault-Encoder disconnection	7301-0200h
Er02-1	Encoder fault-Encoder feedback deviation too large	7300-0201h
Er02-2	Encoder fault-odd/even check error	7300-0202h
Er02-3	Encoder fault-CRC check error	7300-0203h
Er02-4	Encoder fault-Frame error	7300-0204h
Er02-5	Encoder fault-Short frame error	7300-0205h
Er02-6	Encoder fault-Encoder communication timeout	7305-0206h
Er02-7	Encoder fault-Encoder multi-turn error	7306-0207h
Er02-8	Encoder fault-Encoder battery low-voltage	5114-0208h

Display	Fault name	32-bit fault code (16-bit error code + 16-bit additional information)
	alarm	
Er02-9	Encoder fault-Encoder battery undervoltage fault	5115-0209h
Er02-a	Encoder fault-Encoder overheating	7300-020Ah
Er02-b	Encoder fault-Encoder EEPROM writing error	7300-020Bh
Er02-c	Encoder fault-No data in encoder EEPROM	7300-020Ch
Er02-d	Encoder fault- Encoder EEPROM data check error	7300-020Dh
Er03-0	Current sensor fault-Phase-U current sensor fault	7200-0300h
Er03-1	Current sensor fault-Phase-V current sensor fault	7200-0301h
Er03-2	Current sensor fault-Phase-W current sensor fault	7200-0302h
Er04-0	System initialization fault	6100-0400h
Er05-1	Setting fault-Motor model not exist	6320-0501h
Er05-2	Setting fault-Motor and drive model not match	6320-0502h
Er05-3	Setting fault-Incorrect software limits	6320-0503h
Er05-4	Setting fault-Incorrect homing mode	6320-0504h
Er05-5	Setting fault-PTP-control travel overflow	6320-0505h
Er07-0	Regenerative discharge overload fault	7112-0700h
Er08-0	AI overvoltage fault-AI 1	7200-0800h
Er08-1	AI overvoltage fault-AI 2	7200-0801h
Er08-2	AI overvoltage fault-analog input 3	7200-0802h
Er09-0	EEPROM fault-Read/write error	5520-0900h
Er09-1	EEPROM fault-Data check error	5530-0901h
Er10-0	Hardware fault-FPGA fault	7700-0-A00h
Er10-1	Hardware fault- Communication card fault	7500-0-A01h
Er10-2	Hardware fault-To-ground short circuit fault	2300-0-A02h
Er10-3	Hardware fault-External input fault	5430-0-A03h
Er10-4	Hardware fault-Emergency stop fault	5430-0-A04h
Er10-5	Hardware fault-485 communication fault	7500-0-A05h
Er11-0	Software fault-Motor control task re-entry	6100-0-B00h
Er11-1	Software fault-Periodic task re-entry	6100-0-B01h

Display	Fault name	32-bit fault code (16-bit error code + 16-bit additional information)
Er11-2	Software fault–Illegal operation	6100-0-B02h
Er12-0	I/O fault–Duplicate DI assignment	6320-0-C00h
Er12-1	I/O fault–Duplicate AI assignment	6320-0-C01h
Er12-2	I/O fault–Pulse input frequency too high	5430-0-C02h
Er13-0	Main circuit overvoltage fault	3110-0-D00h
Er13-1	Main circuit undervoltage fault	3120-0-D01h
Er14-0	Control power undervoltage fault	5115-0-E00h
Er17-0	Drive overload fault	3230-1100h
Er18-0	Motor overload fault	3230-1200h
Er18-1	Motor overtemperature fault	4310-1701h
Er19-0	Speed fault–Overspeed fault	8400-1300h
Er19-1	Speed fault–FWD overspeed fault	8400-1301h
Er19-2	Speed fault–REV overspeed fault	8400-1302h
Er19-3	Speed fault–Incorrect overspeed parameter <input type="checkbox"/> setting	6320-1303h
Er20-0	Speed out-of-tolerance fault	8400-1400h
Er21-0	Position overtravel - FWD overtravel	8500-1500h
Er21-1	Position overtravel - REV overtravel	8500-1501h
Er22-0	Position out-of-tolerance fault	8611-1600h
Er22-1	Hybrid control deviation too large	8611-1601h
Er22-3	Position increment overflow fault	8611-1603h
Er22-4	CANopen fault–Synchronization signal timeout	7500-1604h
Er23-0	Drive overtemperature fault	4210-1700h
Er24-0	PROFIBUS-DP fault-PWK parameter ID error	6320-1800h
Er24-1	PROFIBUS-DP fault-PWK parameter out-of-range	6320-1801h
Er24-2	PROFIBUS-DP fault-Read-only PWK parameter	6320-1802h
Er24-3	PROFIBUS-DP fault-PZD setting parameter does not exist	6320-1803h
Er24-4	PROFIBUS-DP fault-PZD setting parameter property does not match	6320-1804h
Er25-4	Application fault–Encoder offset angle test timeout	FF00-1904h
Er25-5	Application fault–Encoder offset angle test	FF00-1905h

Display	Fault name	32-bit fault code (16-bit error code + 16-bit additional information)
	failed	
Er25-6	Application fault-Homing offside	FF00-1906h
Er25-7	Application fault-Inertia identifying failed	FF00-1907h
Er26-0	CANopen fault-SDO timeout	8100-1-A00h
Er26-1	CANopen fault-SDO index does not exist	8100-1-A01h
Er26-2	CANopen fault-SDO sub index does not exist	8100-1-A02h
Er26-3	CANopen fault-SDO data length error	8100-1-A03h
Er26-4	CANopen fault-SDO write data beyond the range	8100-1-A04h
Er26-5	CANopen fault-Read-only and non-modifiable	8100-1-A05h
Er26-6	CANopen fault-PDO mapping length error	8100-1-A06h
Er26-7	CANopen fault-PDO mapping data does not exist	8100-1-A07h
Er26-8	CANopen fault-PDO is not allowed to be changed during operating	8100-1-A08h
Er26-9	CANopen fault-PDO mapping is not allowed	8100-1-A09h
Er26-a	CANopen fault-Sync signal is too fast	8100-1-A0Ah
Er26-b	CANopen fault-Receiving fault	8100-1-A0Bh
Er26-c	CANopen fault-Sending fault	8100-1-A0Ch
Er26-d	CANopen fault-Sync signal repeat	8100-1-A0Dh
Er26-e	CANopen fault-Bus load ratio too high	8100-1-A0Eh
Er26-f	CANopen fault-Incorrect parameter modification state	8100-1-A0Fh

9 Function description

The function code list detailedly lists the function code, function code name, setting range, default value, unit, applicable mode, data size, and data format.

- The function codes with the superscript of “¹” indicate that these parameters can be valid only when the system is reset and restarted or repowered after disconnection. The function codes with the superscript of “²” indicate that these parameters are valid when the servo drive stops. The modification during operation is invalid. The function codes with the superscript of “*” indicate that these parameters are not saved after power off.
- In the applicable modes, P indicates position mode, S indicates speed mode, and T indicates torque mode.
- The definition of direction: From the angle of facing motor shaft, the counterclockwise direction is forward (CCW for short); clockwise (CW) is reverse; in terms of speed and torque reference value, positive value means position direction and negative value means negative direction.
- Modbus communication address is decimal, and the communication address of PROFIBUS-DP is the same with that of Modbus. CANopen communication address is hex and the length of 16-bit is the primary code and the length of 8-bit is the sub-code.

9.1 Basic control (Group P0 parameters)

9.1.1 Basic settings

P0.00 ¹	Motor model	Setting range	Default	Unit	Applicable mode		
		0-9999999	0	-	P	S	T
This parameter is set to 0 by default. Users must set according to motor nameplate. If the motor model is 0, and the motor is standard communication-type encoder motor, the drive will read the motor parameters automatically. Note: Improper parameter value will result in abnormal operation of servo system, or even lead to serious drive or motor faults. Double check whether this parameter matches with the motor before the initial power up.							
P0.00 ¹	Data size	32bit	Data format	DEC			
	Modbus communication address	1000, 1001	CANopen communication address	0x2000, 0x00			

P0.01 ¹	Encoder type	Setting range	Default	Unit	Applicable mode		
		1-17	1* ¹	-	P	S	T

In most cases, if P0.00 is set correctly, the system assigns a value to this parameter. If an encoder disconnection fault is reported during power-on though the motor is connected correctly, check whether the drive supports the encoder used by the motor. For details, see section [2.1.1 Product model and nameplate](#). The servo motor code contains the encoder type.

The mapping between encoder types and settings of P0.01 is as follows:

Motor nameplate encoder type ²	Set value	Meaning
1	1	2500-PPR standard incremental type
2	2	2500-PPR economical incremental type
3	3	17-bit single-turn absolute value
4	[4]	17-bit multi-turn absolute value* ³
5	5	20-bit Nikon single-turn absolute value
6	6	20-bit Nikon multi-turn absolute value* ³
7	8	16-bit rotary transformer
8	9	23-bit single-turn absolute value
9	10	23-bit multi-turn absolute value* ³
10	11	17-bit Nikon single-turn absolute value
11	12	17-bit Nikon multi-turn absolute value* ³
12	13	24-bit Nikon single-turn absolute value
13	14	24-bit Nikon multi-turn absolute value* ³
14	15	BISS_C protocol encoder
15	16	EnDat protocol encoder

	16	17	Reagle 10000-PPR encoder	
*1 The encoder type varies with the motor type.				
*3 If you use a multi-turn encoder, change the battery only when the drive power is on, which prevents the absolute position from being lost. The standard battery is 2000 mAh and the replacement cycle is 1.5–2 years.				
P0.01 ¹	Data size	16bit	Data format	DEC
	Modbus communication address	1002, 1003	CANopen communication address	0x2001, 0x00

P0.02 ¹	Forward rotation of motor	Setting range	Default	Unit	Applicable mode		
		0–1	0	-	P	S	T

Set the forward rotation of motor:

Set value	Meaning
[0]	Anticlockwise is forward rotation
1	Clockwise is forward rotation

 **Note:** Definition of forward rotation of motor. The view angle faces shaft output direction of motor.

P0.02 ¹	Data size	16bit	Data format	DEC
	Modbus communication address	1004, 1005	CANopen communication address	0x2002, 0x00

P0.03 ¹	Control mode selection	Setting range	Default	Unit	Applicable mode		
		0–9	0	-	P	S	T

This parameter can be used to set the operating mode of the system:

Set value	First working mode	Second working mode	Description
[0]	P	/	Position mode: Control the angular displacement of servo motor via internal/external position command, thus achieving controlling over mechanical motion displacement.
1	S	/	Speed mode: Control the rotation speed of the servo motor with the internal or external speed command.
2	T	/	Torque mode: Control the torque of the servo motor with the

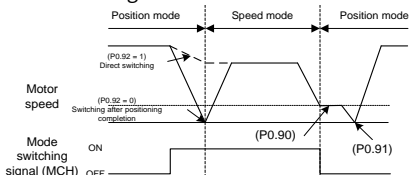
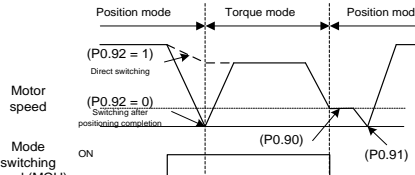
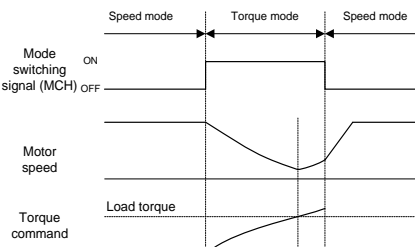
<p>3</p>	<p>P</p>	<p>S</p>	<p>internal or external torque command.</p> <p>Switching between the position and speed modes: The position mode and speed mode can be switched through the control mode switching terminal.</p>  <p>Note: There are two methods (specified by P0.92) to switch from the position mode to the speed mode. In the process of switching from the speed mode to the position mode, the motor stops at the reference position specified by P0.91 before switching to the position mode.</p>
<p>4</p>	<p>P</p>	<p>T</p>	<p>Switching between the position and torque modes: The position mode and torque mode can be switched through the control mode switching terminal.</p>  <p>Note: There are two methods (specified by P0.92) to switch from the position mode to the torque mode. In the process of switching from the torque mode to the position mode, the motor stops at the reference position specified by P0.91 before switching to the position mode.</p>
<p>5</p>	<p>S</p>	<p>T</p>	<p>Switching between the speed and torque modes: The speed mode and torque mode can be switched through the control mode switching terminal.</p> 

			Note: The switching is not limited by the current working condition.
6	/	/	(Reserved)
7	CANopen	/	CANopen mode (supported by the CANopen servo)
8	EtherCAT	/	EtherCAT mode (supported by the EtherCAT servo)
9	MotionNet	/	MotionNet mode (supported by the MotionNet servo)

Note: If P0.03 is set, parameters P3.00–P3.09 are automatically switched according to the current control mode.

0: OFF (The internal optical coupler corresponding to the input is not conducted.)

1: ON (The internal optical coupler corresponding to the input is conducted.)

P0.03 ¹	Data size	16bit	Data format	DEC
	Modbus communication address	1006, 1007	CANopen communication address	0x2003, 0x00

P0.04*	Internal enabling command	Setting range	Default	Unit	Applicable mode		
		0–1	0	-	P	S	T

This parameter is used to control the running state of the servo drive.

The mapping between the settings of this parameter and external terminal enabling commands are as follows:

Set value	External terminal command state	Working state of servo drive
0	0 (The internal optical coupler corresponding to the input is not conducted.)	Stand-by (OFF)
0	1 (The internal optical coupler corresponding to the input is conducted.)	Enabled (ON)
1	0 (The internal optical coupler corresponding to the input is not conducted.)	Enabled (ON)
1	1 (The internal optical coupler corresponding to the input is conducted.)	Enabled (ON)

Note:

- If P0.04 is set to 1, but the external terminal command status is changed from 1 to 0, the drive is disabled, that is, P0.04 is changed to 0 automatically.
- The method for setting this parameter on the LED panel is different from that for setting

other parameters. You can use only the SET key to switch between 0 and 1. The UP/DOWN key is invalid on the screen for setting this parameter.				
P0.04*	Data size	16bit	Data format	DEC
	Modbus communication address	1008, 1009	CANopen communication address	0x2004, 0x00

P0.05	Jogging speed	Setting range	Default	Unit	Applicable mode		
		0-1000	200	r/min	P	S	T

The jog speed can be set via parameter P0.05. For details about jogging, see section [6.1.5.2 Operation flowchart of trial jogging](#). During the jogging process, the ACC/DEC time parameters (P0.54, P0.55, P0.56, and P0.57) are active, and the motor accelerates, decelerates, starts, or stops based on the settings.

P0.05	Data size	16bit	Data format	DEC
	Modbus communication address	1010, 1011	CANopen communication address	0x2005, 0x00

P0.06 ¹	Numerator of frequency division output coefficient	Setting range	Default	Unit	Applicable mode		
		0-(2 ³¹ -1)	10000	-	P	S	T
P0.07 ¹	Denominator of frequency division output coefficient	Setting range	Default	Unit	Applicable mode		
		1-(2 ³¹ -1)	131072	-	P	S	T

By setting the numerator and denominator of the frequency division output coefficient, the position from the encoder feedback can be frequency divided by any integer or decimal fraction and then output through the encoder pulse output signal terminals (OA+, OA-, OB+ and OB-, corresponding to pins 44, 43, 41, and 42) of the CN1 plug.

$$\text{Drive output pulses} = \frac{\text{P0.06}}{\text{P0.07}} \times \text{Encoder resolution}$$

Note:

- In position control mode, if the encoder output signal of the upper-level servo motor is used as the position pulse command input of the current-level servo drive, that is, executing the master/slave follow-up of the start/stop type, in order to ensure high positioning accuracy of the current-level servo drive, the frequency division coefficient must be 1:1. Otherwise, the accuracy of master/slave position follow-up is affected.
- By default, P0.07 is 131072 and P0.06 is 10000, indicating the encoder pulse output terminal outputs 10000 pulse signals each time the motor rotates a circle. If P0.06 is

changed to 5000, the encoder pulse output terminal outputs 5000 pulse signals in the same situation.

P0.06 ¹	Data size	32bit	Data format	DEC
	Modbus communication address	1012, 1013	CANopen communication address	0x2006, 0x00
P0.07 ¹	Data size	32bit	Data format	DEC
	Modbus communication address	1014, 1015	CANopen communication address	0x2007, 0x00

P0.08 ¹	Reverse of frequency division output	Setting range	Default	Unit	Applicable mode		
		0-1	0	-	P	S	T

This parameter specifies whether to reverse the phase-B pulse logic of pulse output. Then the phase relationship between phase-A pulses and phase-B pulses can be changed.

Set value	Logic of phase B	CCW	CW
[0]	Not reverse		
1	Reverse		

P0.08 ¹	Data size	16bit	Data format	DEC
	Modbus communication address	1016, 1017	CANopen communication address	0x2008, 0x00

P0.09	Torque limit mode setting	Setting range	Default	Unit	Applicable mode		
		0-6	1	-	P	S	

This parameter is used to set the torque limit mode.

Set value	Forward direction	Reverse direction
0	Torque limit	Torque limit

	(analog input 0V–10V)	(analog input -10V–0V)
[1]	Max. torque limit 1 (P0.10)	
2	Max. torque limit 1 (P0.10)	Max. torque limit 2 (P0.11)
3	TLC OFF→ Max. torque limit 1 (P0.10) TLC ON→ Max. torque limit 2 (P0.11)	
4	Forward torque limit (analog input 0V–10V)	Negative torque limit (analog input 0V–10V)
5	Forward torque limit (analog input 0V–10V)	
6	Torque command (analog input 0V–10V)	

Note: If P0.09 is set to 3, torque switching does not take effect immediately, but limited by the settings of P4.51 and P4.52. The torque switching limit is shown in the following figure.

$$T_a[\text{ms}] = |\text{P0.11}[\%] - \text{P0.10}[\%]| \times \text{P4.51}[\text{ms}/100\%]/100$$

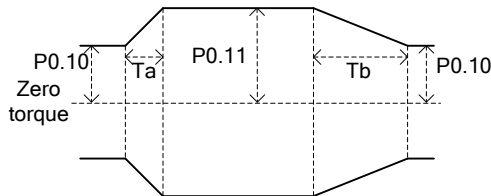

$$T_b[\text{ms}] = |\text{P0.10}[\%] - \text{P0.11}[\%]| \times \text{P4.52}[\text{ms}/100\%]/100$$

P0.09	Data size	16bit	Data format	DEC
	Modbus communication address	1018, 1019	CANopen communication address	0x2009, 0x00

P0.10	Max. torque limit 1	Setting range	Default	Unit	Applicable mode		
		0.0–500.0	300.0	%	P	S	T
P0.11	Max. torque limit 2	Setting range	Default	Unit	Applicable mode		
		0.0–500.0	300.0	%	P	S	-

These parameters can be used to set the maximum torque of the servo motor output. Taking the rated torque of the servo motor as 100%, the setting is the percentage of the rated torque of the servo motor. If the absolute value of the torque command is larger than the value of this parameter, then the actual output torque will be limited by the parameter.

Note:

- These parameters are used with P0.09.
- In torque mode, the limit value is determined by P0.10.

P0.10	Data size	16bit	Data format	DEC
	Modbus communication address	1020, 1021	CANopen communication address	0x200A, 0x00
P0.11	Data size	16bit	Data format	DEC
	Modbus communication address	1022, 1023	CANopen communication address	0x200B, 0x00

P0.13 ¹	External braking resistor power	Setting range	Default	Unit	Applicable mode		
		0-30000	200	W	P	S	T
P0.14 ¹	Resistance of the external braking resistor	Setting range	Default	Unit	Applicable mode		
		1-1000	60	Ω	P	S	T

If an external brake resistor is used, the settings of the parameters must be the same as the power and resistance of the external brake resistor.

Note: Brake overload detection should be used with P4.34. If P4.34 is set to 2, the brake overload detection logic uses the external brake resistor parameters to execute fault detection. If this group of parameter does not match the power and resistance of the external brake resistor, the brake overload fault (Er07-0) may be reported by mistake or even the brake resistor may be burnt down. The regenerative brake overload protection time of the external brake resistor is in direct proportion to the two parameters and is in inverse proportion to the brake rate during actual running. The two parameters are invalid when P4.34 is not 2.

P0.13 ¹	Data size	16bit	Data format	DEC
	Modbus communication address	1026, 1027	CANopen communication address	0x200D, 0x00
P0.14 ¹	Data size	16bit	Data format	DEC
	Modbus communication address	1028, 1029	CANopen communication address	0x200E, 0x00

P0.15	Default monitoring parameters	Setting range	Default	Unit	Applicable mode		
		0-23	0	-	P	S	T

This parameter specifies the status parameters that are monitored upon power-on. For details, see section [A.1.2 State monitoring parameter list](#).

P0.15	Data size	16bit	Data format	DEC
	Modbus communication address	1030, 1031	CANopen communication address	0x200F, 0x00

P0.16	Parameter modification operation locked	Setting range	Default	Unit	Applicable mode		
		0-1	0	-	P	S	T

This parameter is used to lock the parameter modification function (exclude P0.16 and parameters which cannot be saved after power off) to avoid mis-operation by users.

Set value	Panel operation	Communication operation	
	[0]	Parameter modification valid	Parameter modification valid
	1	Parameter modification invalid	Parameter modification invalid

P0.16	Data size	16bit	Data format	DEC
	Modbus communication address	1032, 1033	CANopen communication address	0x2010, 0x00

P0.17	Mode for writing to EEPROM	Setting range	Default	Unit	Applicable mode		
		0-1	0	-	P	S	T

This parameter specifies the mode for writing parameter settings that are modified through the panel to the EEPROM.

Set value	Command pulse input	
	[0]	Saved one by one (automatic saved after modification)
	1	Bulk saving (be saved in bulk by P4.91 after modification)

P0.17	Data size	16bit	Data format	DEC
	Modbus communication address	1034, 1035	CANopen communication address	0x2011, 0x00

P0.18*	Factory password	Setting range	Default	Unit	Applicable
--------	------------------	----------------------	----------------	-------------	-------------------

					mode		
		0-32767	0	-	P	S	T
This parameter enables you to view factory parameters and modify menus.							
P0.18*	Data size	16bit	Data format	DEC			
	Modbus communication address	1036, 1037	CANopen communication address	0x2012, 0x00			

9.1.2 Position control

P0.20 ¹	Position command selection	Setting range	Default	Unit	Applicable mode		
		0-4	0	-	P	-	-
This parameter specifies the position command source in the position, fully-closed loop, and hybrid position control modes.							
	Set value	Position command source					
	[0]	Pulse input					
	1	Communication bus input					
	2	PTP control					
	3	(Reserved)					
	4	Second encoder input					
P0.20 ¹	Data size	16bit	Data format	DEC			
	Modbus communication address	1040, 1041	CANopen communication address	0x2014, 0x00			
P0.22 ¹	Pulses per motor resolution	Setting range	Default	Unit	Applicable mode		
		0-(2 ³¹ -1)	10000	reference unit	P	-	-
This parameter specifies the number of pulses required per motor resolution.  Note: If P0.22 is set to a non-zero value, the settings of P0.25–P0.29 are invalid. If a 17-bit or 20-bit encoder is used together, you are recommended to set a greater value to achieve higher accuracy.							
P0.22 ¹	Data size	32bit	Data format	DEC			
	Modbus communication address	1044, 1045	CANopen communication address	0x2016, 0x00			

P0.23 ¹	Pulse input form	Setting range	Default	Unit	Applicable mode		
		0-2	0	-	P	-	-

This parameter specifies the pulse input mode. There are three pulse input modes available.

Set value	Pulse input form	Signal form	Diagram	
			CCW	CW
[0]	Pulse + sign	Pulse+Sign		
1	CCW/CW pulse train	CW+CCW		
2	Quadrature encoder pulse mode	QEP		

Note: The pulse direction specified by this parameter can be reversed by P0.24¹. See P0.24¹ for details.

P0.23 ¹	Data size	16bit	Data format	DEC
	Modbus communication address	1046, 1047	CANopen communication address	0x2017, 0x00

P0.24 ¹	Reverse of pulse input direction	Setting range	Default	Unit	Applicable mode		
		0-1	0	-	P		

By setting this parameter, the input pulse direction can be reversed. At this time, the actual output speed direction of the servo drive is opposite to the direction specified by P0.23¹.

Set value	Command pulse input
[0]	Pulse input direction does not change.
1	Pulse input direction is opposite to the original input direction.

P0.24 ¹	Data size	16bit	Data format	DEC
	Modbus communication address	1048, 1049	CANopen communication address	0x2018, 0x00

Parameter	Description	Setting range	Default	Unit	Applicable mode		
		P0.25	Numerator of electronic gear ratio 1	0-(231-1)	0	-	P
P0.26	Denominator of electronic gear ratio	1-(231-1)	10000	-	P	-	-
P0.27	Numerator of electronic gear ratio 2	0-(231-1)	0	-	P	-	-
P0.28	Numerator of electronic gear ratio 3	0-(231-1)	0	-	P	-	-
P0.29	Numerator of electronic gear ratio 4	0-(231-1)	0	-	P	-	-

Concept of the electronic gears: For any pulse input, the quantity and frequency of pulse actually received by the drive can be changed by multiplying a certain coefficient. This coefficient is electronic gear ratio. It can be divided into two parts: numerator and denominator:

$$\text{Electronic gear ratio} = g1 / g2;$$

Of which, g1: indicates the numerator of the electronic gear ratio;

g2: indicates the denominator of the electronic gear ratio;

The following is the schematic diagram for the electronic gear ratio:

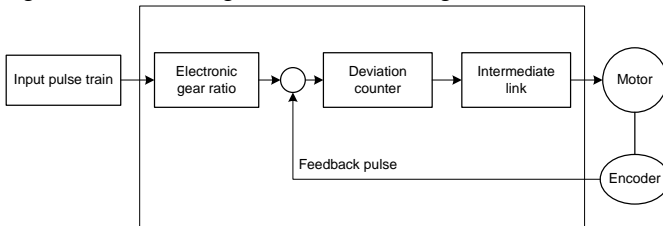

Example: The following is an example where 1 pulse is equivalent to a feed rate of 10μm.

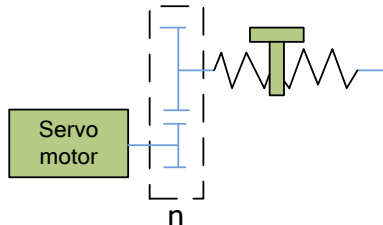

Mechanical specifications: Feed of the ball screw $P_b = 10\text{mm}$;

DEC ratio $n = 3/5$;

Resolution of the servo motor encoder = 10000;

The electronic gear ratio is as follows:

$$\frac{g1}{g2} = \Delta l_0 \cdot \frac{Pt}{\Delta S} = \Delta l_0 \cdot \frac{Pt}{n \cdot Pb} = 10 \times 10^{-3} \cdot \frac{10000}{(3/5) \cdot 10} = \frac{50}{3}$$

In the expression, Δl_0 : Feed corresponding to each pulse (mm/pulse)

ΔS : Feed corresponding to each rotation motor (mm/rotation)

In this example, $g1 = 50$ and $g2 = 3$, so you can set P0.25 to 50 and P0.26 to 3.

The servo drive has four groups of electronic gear ratio. You can determine which parameters are selected from P0.25, P0.26, P0.27, P0.28, and P0.29 to make up the electronic gear ratio through the electronic gear ratio selection terminals SC1 and SC2 of the CN1 plug.

SC1	SC2	Position mode
0	0	Numerator of electronic gear ratio 1
1	0	Numerator of electronic gear ratio 2
0	1	Numerator of electronic gear ratio 3
1	1	Numerator of electronic gear ratio 4

Note:

- This group of parameters is valid only when P0.22¹ is 0.
- If SC1 and SC2 are used for electronic gear ratio switching, P4.10 must be set to 0.

P0.25	Data size	32bit	Data format	DEC
	Modbus communication address	1050, 1051	CANopen communication address	0x2019, 0x00
P0.26	Data size	32bit	Data format	DEC
	Modbus communication address	1052, 1053	CANopen communication address	0x201A, 0x00
P0.27	Data size	32bit	Data format	DEC
	Modbus communication address	1054, 1055	CANopen communication address	0x201B, 0x00
P0.28	Data size	32bit	Data format	DEC
	Modbus	1056, 1057	CANopen	0x201C, 0x00

	communication address		communication address	
P0.29	Data size	32bit	Data format	DEC
	Modbus communication address	1058, 1059	CANopen communication address	0x201D, 0x00

P0.30 ¹	Input selection for 3PH input-type servo power supply	Setting range	Default	Unit	Applicable mode		
		0-1	0	-	P	S	T

This parameter specifies the input type of a three-phase input-type servo unit power supply.

P0.30 ¹	Data size	16bit	Data format	DEC
	Modbus communication address	1060, 1061	CANopen communication address	0x201E, 0x00

P0.31 ¹	Main circuit power AC/DC input selection	Setting range	Default	Unit	Applicable mode		
		0-1	0	-	P	S	T

This parameter specifies the power input type for the main circuit.

P0.31 ¹	Data size	16bit	Data format	DEC
	Modbus communication address	1062, 1063	CANopen communication address	0x201F, 0x00

P0.32	Sudden power-off hold time	Setting range	Default	Unit	Applicable mode		
		20-2000	36	ms	P	-	-

When an instantaneous OFF occurs in the voltage supply to main circuit power supply of the servo unit, you can select whether to continue providing power to the motor or cut off the power supply based on the OFF time.

P0.32	Data size	16bit	Data format	DEC
	Modbus communication address	1064, 1065	CANopen communication address	0x2020, 0x00

P0.33 ²	Smooth filtering of position command	Setting range	Default	Unit	Applicable mode		
		0.0-1000.0	0.0	ms	P	-	-

This parameter is used to set the time constant of the first-order low-pass filter corresponding to the position command. This parameter is used to reduce the mechanical shock caused by sudden input pulse command frequency changes. See the figure below.

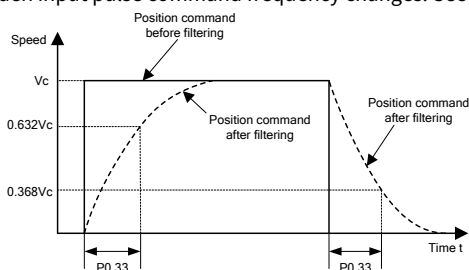

P0.33 ²	Data size	16bit	Data format	DEC
	Modbus communication address	1066, 1067	CANopen communication address	0x2021, 0x00

P0.34 ²	FIR filter of position command	Setting range	Default	Unit	Applicable mode		
		0.0-1000.0	0.0	ms	P	-	-

This parameter is used to set the time constant of the FIR filter corresponding to the position command. This parameter is used to reduce the mechanical shock caused by sudden input pulse command frequency changes. See the figure below.

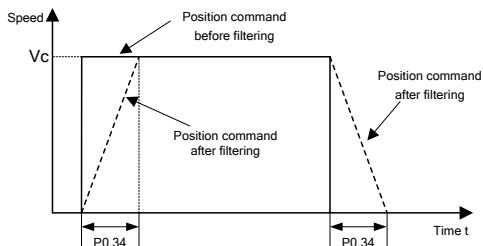

Note: If this parameter is modified during servo running, the modification takes effect after stop.

P0.34 ²	Data size	16bit	Data format	DEC
	Modbus communication address	1068, 1069	CANopen communication address	0x2022, 0x00

P0.35	Software limit in CCW position control	Setting range	Default	Unit	Applicable mode		
		-(231-1)-(231-1)	0	reference unit	P	-	-

This parameter specifies the software limit in CCW position control.

If P0.35 is 0 and P0.36 is 0, software limit is invalid.

Note: The software limit function is valid only when this parameter is greater than P0.36.

P0.35	Data size	32bit	Data format	DEC		
	Modbus communication address	1070, 1071	CANopen communication address	0x2023, 0x00		

P0.36	Software limit in CW position control	Setting range	Default	Unit	Applicable mode		
		-(231-1)-(231-1)	0	reference unit	P	-	-

This parameter specifies the software limit in CW position control.

If P0.35 is 0 and P0.36 is 0, software limit is invalid.

Note: The software limit function is valid only when this parameter is less than P0.35.

P0.36	Data size	32bit	Data format	DEC		
	Modbus communication address	1072, 1073	CANopen communication address	0x2024, 0x00		

P0.37	Position command mode	Setting range	Default	Unit	Applicable mode		
		0-1	0	-	P	-	-

This parameter specifies the position command mode when P0.20 [Position command source] is set to 1, and it is invalid in other modes.

Set value	Position command mode
[0]	Incremental (The position command input is the variation relative to the current position.)
1	Absolute (The position command input is the target position.)

P0.37	Data size	16bit	Data format	DEC		
	Modbus communication	1074, 1075	CANopen communication	0x2025, 0x00		

	address		address										
P0.38	Fully-closed loop enable	Setting range	Default	Unit	Applicable mode								
		0-2	0	-	P - -								
<p>This parameter specifies the enabling of the fully-closed loop function.</p> <p>When it is set to 2, the switching between the fully closed and semi-closed loop function can be conducted through the IO port with function code of 0x34 or 0x134.</p> <p>Note: The difference between setting this parameter to 1 or 2 lies in: The definition of the electronic gear ratio differs when running with the full-closed loop function.</p> <table border="1"> <thead> <tr> <th>Set value</th> <th>Fully-closed loop enable</th> </tr> </thead> <tbody> <tr> <td>[0]</td> <td>Disable</td> </tr> <tr> <td>1</td> <td>Fully-closed loop enable</td> </tr> <tr> <td>2</td> <td>Enable switching between fully-closed loop and semi-closed loop</td> </tr> </tbody> </table>						Set value	Fully-closed loop enable	[0]	Disable	1	Fully-closed loop enable	2	Enable switching between fully-closed loop and semi-closed loop
Set value	Fully-closed loop enable												
[0]	Disable												
1	Fully-closed loop enable												
2	Enable switching between fully-closed loop and semi-closed loop												
P0.38	Data size	16bit	Data format	DEC									
	Modbus communication address	1076, 1077	CANopen communication address	0x2026, 0x00									

9.1.3 Speed/Torque control

P0.40	Speed command selection	Setting range	Default	Unit	Applicable mode																																						
		0-5	1	-	-	S	-																																				
<p>This parameter specifies the command source in speed control.</p> <table border="1"> <thead> <tr> <th>Set value</th> <th>Input mode</th> <th colspan="6">Description</th> </tr> </thead> <tbody> <tr> <td rowspan="3">0</td> <td rowspan="3">Internal speed</td> <td colspan="6">P3.00-P3.09 can be used to control the internal multi-step speed (SPD1 is 0x00A, SPD2 is 0x00B, SPD3 is 0x00C):</td> </tr> <tr> <td>SPD3</td> <td>SPD2</td> <td>SPD1</td> <td>Parameter</td> <td colspan="2">Speed mode</td> </tr> <tr> <td>0</td> <td>0</td> <td>0</td> <td>P0.46</td> <td colspan="2">Internal speed 1</td> </tr> <tr> <td></td> <td></td> <td>0</td> <td>0</td> <td>1</td> <td>P0.47</td> <td colspan="2">Internal</td> </tr> </tbody> </table>								Set value	Input mode	Description						0	Internal speed	P3.00-P3.09 can be used to control the internal multi-step speed (SPD1 is 0x00A, SPD2 is 0x00B, SPD3 is 0x00C):						SPD3	SPD2	SPD1	Parameter	Speed mode		0	0	0	P0.46	Internal speed 1				0	0	1	P0.47	Internal	
Set value	Input mode	Description																																									
0	Internal speed	P3.00-P3.09 can be used to control the internal multi-step speed (SPD1 is 0x00A, SPD2 is 0x00B, SPD3 is 0x00C):																																									
		SPD3	SPD2	SPD1	Parameter	Speed mode																																					
		0	0	0	P0.46	Internal speed 1																																					
		0	0	1	P0.47	Internal																																					

					speed 2
		0	1	0	P0.48 Internal speed 3
		0	1	1	P0.49 Internal speed 4
		1	0	0	P0.50 Internal speed 5
		1	0	1	P0.51 Internal speed 6
		1	1	0	P0.52 Internal speed 7
		1	1	1	P0.53 Internal speed 8
		See the descriptions for P0.46–P0.53.			
[1]	Analog input	You need to set P3.26 [Function of AI 1], P3.27 [Function of AI 2] or P3.70 [Function of analog input 3] to 3 [Speed command], and set associated parameters according to the actual situation.			
2	Bus input	The communication bus interface can be used to receive speed commands from the upper computer. If P4.10 is 1 [Bus input], the motor speed can be changed by P4.13 [Bus speed command]. See the descriptions for P4.10 and P4.13.			
3	(Reserved)	-			
4	(Reserved)	-			
5	Internal speed with high resolution	High resolution internal speed, precision 0.1r/min			
P0.40	Data size	16bit	Data format	DEC	
	Modbus communication address	1080, 1081	CANopen communication address	0x2028, 0x00	
P0.41	Setting of speed command direction	Setting range	Default	Unit	Applicable mode
		0–1	0	-	- S -
This parameter is used to set the forward/reverse direction when P0.40 is 0 and 1 and the speed command sign is selected as S-SIGN.					

	Set value	Internal speed step/analog input		Speed command sign	Speed command direction
	[0]	Positive speed	0V-10V	Not work	Forward direction
		Negative speed	-10V-0V	Not work	Reverse direction
	1	Not work		Valid	Forward direction
Not work		Invalid	Reverse direction		
P0.41	Data size		16bit	Data format	DEC
	Modbus communication address		1082, 1083	CANopen communication address	0x2029, 0x00

P0.42	Analog input 1 gain	Setting range	Default	Unit	Applicable mode		
		10-2000	100	[P3.26 unit]/V	P	S	T

This parameter specifies the gain of analog input 1, the gain unit is associated with P3.26.

Note:

- Analog input 1 indicates the signal input from the terminals (that is, AD1 and GND, corresponding to pin 1 and pin 5) of analog input 1 of the CN1 plug.
- The voltage only in the -10V+10V range can be applied to the connection between AD1 and GND. Otherwise, the drive may be damaged.

Application example:

1. The function of analog input 1 is speed command.
2. The voltage of analog input 1 corresponds to the conversion gain of the motor command speed.
3. When P0.40 is set to “1” , this parameter is valid.
4. The relationship between the voltage of analog input 1 and speed command is as follows:
Every 1V voltage corresponds to the 100 r/min speed by default.

Actual speed command = Analog input voltage x P0.42

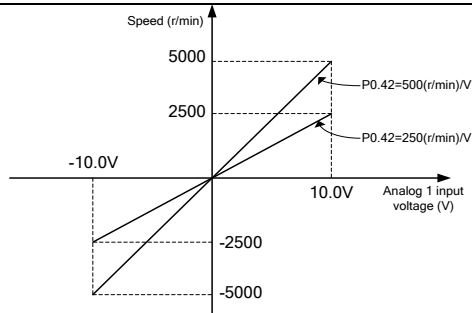

Note:

- When P0.40 is set to “1”, this parameter is valid.
- Set this parameter according to the motor working condition. If this parameter is set to a large value, the motor speed may fluctuate sharply.

P0.42	Data size	32bit	Data format	DEC
	Modbus communication address	1084, 1085	CANopen communication address	0x202A, 0x00

P0.43	Reverse of AI 1	Setting range	Default	Unit	Applicable mode		
		0-1	0	-	P	S	T

This parameter specifies the voltage polarity of analog input 1.

Set value	Actual detection result	
[0]	Positive polarity	[+Voltage]→[Positive value], [-Voltage]→[Negative value]
1	Negative polarity	[+Voltage]→[Negative value], [-Voltage]→[Positive value]

P0.43	Data size	16bit	Data format	DEC
	Modbus communication address	1086, 1087	CANopen communication address	0x202B, 0x00

P0.45	Dead zone of AI 1	Setting range	Default	Unit	Applicable mode		
		0.000-3.000	0.000	V	P	S	T

If the absolute voltage value of analog input 1 falls in the range of this parameter, the corresponding command value is 0.

P0.45	Data size	16bit	Data format	DEC
	Modbus communication address	1090, 1091	CANopen communication address	0x202D, 0x00

P0.46	Internal speed 1/speed limit 1	Setting range	Default	Unit	Applicable mode		
		-20000~20000	100	r/min	-	S	T
P0.47	Internal speed 2/speed limit 2	Setting range	Default	Unit	Applicable mode		
		-20000~20000	0	r/min	-	S	T
P0.48	Internal speed 3/speed limit 3	Setting range	Default	Unit	Applicable mode		
		-20000~20000	0	r/min	-	S	T
P0.49	Internal speed 4/speed limit 4	Setting range	Default	Unit	Applicable mode		
		-20000~20000	0	r/min	-	S	T
P0.50	Internal speed 5	Setting range	Default	Unit	Applicable mode		
		-20000~20000	0	r/min	-	S	-
P0.51	Internal speed 6	Setting range	Default	Unit	Applicable mode		
		-20000~20000	0	r/min	-	S	-
P0.52	Internal speed 7	Setting range	Default	Unit	Applicable mode		
		-20000~20000	0	r/min	-	S	-
P0.53	Internal speed 8	Setting range	Default	Unit	Applicable mode		
		-20000~20000	0	r/min	-	S	-

The servo drive supports the 8-step internal speed commands and 4-step internal speed limits.

Control mode	Set value of P0.40	SPD3	SPD2	SPD1	Related parameter and set value
Speed mode	0	0	0	0	P0.46 internal speed 1
		0	0	1	P0.47 internal speed 2

		0	1	0	P0.48 internal speed 3
		0	1	1	P0.49 internal speed 4
		1	0	0	P0.50 internal speed 5
		1	0	1	P0.51 internal speed 6
		1	1	0	P0.52 internal speed 7
		1	1	1	P0.53 internal speed 8
Torque mode	0	0	0	0	P0.46 speed limit 1
		0	0	1	P0.47 speed limit 2
		0	1	0	P0.48 speed limit 3
		0	1	1	P0.49 speed limit 4

Note:

- SPD1, SPD2, SPD3 are the digital inputs of internal speed commands 1, 2, and 3 (corresponding to 0x00A, 0x00B, and 0x00C). 0: Off (The internal optical coupler corresponding to the input is not conducted.); 1: On (The internal optical coupler corresponding to the input is conducted.)
- The speed limits depend on the absolute values of the parameters and, the directions are the same as those in torque commands.

P0.46	Data size	16bit	Data format	DEC
	Modbus communication address	1092, 1093	CANopen communication address	0x202E, 0x00
P0.47	Data size	16bit	Data format	DEC
	Modbus communication address	1094, 1095	CANopen communication address	0x202F, 0x00
P0.48	Data size	16bit	Data format	DEC
	Modbus communication address	1096, 1097	CANopen communication address	0x2030, 0x00
P0.49	Data size	16bit	Data format	DEC
	Modbus communication address	1098, 1099	CANopen communication address	0x2031, 0x00

P0.50	Data size	16bit	Data format	DEC
	Modbus communication address	1100, 1101	CANopen communication address	0x2032, 0x00
P0.51	Data size	16bit	Data format	DEC
	Modbus communication address	1102, 1103	CANopen communication address	0x2033, 0x00
P0.52	Data size	16bit	Data format	DEC
	Modbus communication address	1104, 1105	CANopen communication address	0x2034, 0x00
P0.53	Data size	16bit	Data format	DEC
	Modbus communication address	1106, 1107	CANopen communication address	0x2035, 0x00

P0.54	ACC time	Setting range	Default	Unit	Applicable mode		
		0-6000000	200	ms	-	S	-
P0.55	DEC time	Setting range	Default	Unit	Applicable mode		
		0-6000000	200	ms	-	S	-

ACC/DEC time is the time taken to accelerate from 0 r/min to the rated (3000 r/min by default) speed in the given command or decelerates from the rated speed to 0 r/min. If the given speed is not equal to the rated speed, the actual ACC/DEC time is the set ACC/DEC time multiplied by the ratio of the given speed to the rated speed. If the speed command is negative, the absolute value is used to calculate the ACC/DEC time.

Example: If the given speed is 2000 r/min, the rated speed is 3000 r/min, and the ACC/DEC time (P0.54/P0.55) is set to 1500, then the actual ACC time t_1 is $1500 \times (2000/3000)=1000\text{ms}$ and the DEC time t_2 is $1500 \times (2000/3000)=1000\text{ms}$.

See the following figure:

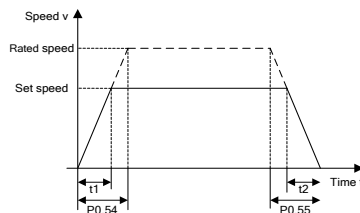

Note: ACC/DEC time can be used in the speed mode only.

P0.54	Data size	16bit	Data format	DEC
	Modbus communication address	1108, 1109	CANopen communication address	0x2036, 0x00
P0.55	Data size	16bit	Data format	DEC
	Modbus communication address	1110, 1111	CANopen communication address	0x2037, 0x00

P0.56	S-curve ACC time	Setting range	Default	Unit	Applicable mode		
		0-1000	0	ms	-	S	-
P0.57	S-curve DEC time	Setting range	Default	Unit	Applicable mode		
		0-1000	0	ms	-	S	-

In a rated-speed command, this group of parameter is used to set the duration of the circular arc segments in the S curve, thus achieving the goal of smooth starting. The S-curve ACC/DEC time is shown in the following figure:

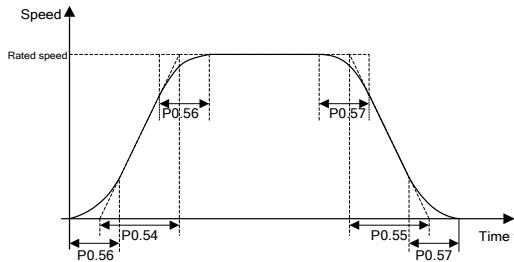

Note:

- ACC/DEC time of S curve can be used in speed mode only.
- If the speed command is analog input, S curve ACC/DEC time is invalid.
- If the setting value of P0.54 is less than that of P0.56 and P0.56 is not 0, P0.54 is equal to P0.56 during actual running.
- If the setting value of P0.55 is less than that of P0.57 and P0.57 is not 0, P0.55 is equal to P0.57 during actual running.

P0.56	Data size	16bit	Data format	DEC
	Modbus communication address	1112, 1113	CANopen communication address	0x2038, 0x00

P0.57	Data size	16bit	Data format	DEC
	Modbus communication address	1114, 1115	CANopen communication address	0x2039, 0x00

P0.58	Zero speed clamp mode	Setting range	Default	Unit	Applicable mode		
		0-3	0	-	-	S	T

This parameter specifies the zero speed clamp mode.

Set value	Position command mode
[0]	Invalid (The zero speed clamp input is ignored.)
1	If the zero speed clamp control signal is valid, the speed command is forcibly set to 0.
2	If the zero speed clamp control signal is valid, the speed command is forcibly set to 0, the position control mode is used when the actual motor speed becomes less than P0.59 [Speed threshold in zero speed clamp], and the servo is locked at this position. Other actions are the same with setting value 1.
3	If the zero speed clamp control signal is valid, when the speed command changes to be -10r/min below P0.59, it will switch to position control and be locked in the position.

Note:

- If any one of P3.00–P3.09 is zero speed clamp function (0x00D), it can be controlled by the corresponding digital input of CN1; it can also be controlled by P4.19. 0: Disable zero speed clamp. 1: Enable zero speed clamp.
- In the torque mode, mode 0 and 1 are valid, mode 2 and 3 are the same with mode 1.

P0.58	Data size	16bit	Data format	DEC
	Modbus communication address	1116, 1117	CANopen communication address	0x203A, 0x00

P0.59	Speed threshold of zero speed clamp	Setting range	Default	Unit	Applicable mode		
		10-20000	30	r/min	-	S	-

This parameter specifies the speed threshold for switching to position control when P0.58 is 2 or 3. When P0.58 is 3, there is a 10 r/min delay detected.

P0.59	Data size	16bit	Data format	DEC
	Modbus communication address	1118, 1119	CANopen communication	0x203B, 0x00

			address	
--	--	--	---------	--

P0.60	Torque command selection	Setting range	Default	Unit	Applicable mode		
		0-3	1	-	-	-	T

This parameter specifies the command source in torque control.

Set value	Input mode	Description
0	Internal setting	Set the torque command by P0.66.
[1]	Analog input	You need to set P3.26 [Function of AI 1] or P3.27 [Function of AI 2] to 4 [Torque command] and set associated parameters according to the actual situation.
2	Bus input	The communication bus interface can be used to receive torque commands from the upper computer. If P4.10 is 1 [Bus input], the motor speed can be changed by P4.14 [Bus torque command]. See the descriptions for P4.10 and P4.14.
3	(Reserved)	-

P0.60	Data size	16bit	Data format	DEC
	Modbus communication address	1120, 1121	CANopen communication address	0x203C, 0x00

P0.61	Torque command direction setting	Setting range	Default	Unit	Applicable mode		
		0-1	0	-	-	-	T

This parameter specifies the method for specifying the direction in a torque command.

Set value	Designated method
[0]	The torque command sign specifies the direction. For example, Torque command input [+] indicates forward, while [-] indicates reverse.
1	The torque command sign [0x00F] of the digital input function is used to specify the direction. 1: Forward direction 2: Reverse direction

 **Note:** 0x00F is valid when the input is a low electrical level, while 0x10F is valid when the input is a high electrical level.

P0.61	Data size	16bit	Data format	DEC
	Modbus communication address	1122, 1123	CANopen communication address	0x203D, 0x00

P0.62	Analog input 2 gain	Setting range	Default	Unit	Applicable mode		
		0–2000	100	[P3.27 unit]/V	P	S	T

This parameter specifies the gain of analog input 2, the gain unit is associated with P3.27.

Note: Analog input 2 indicates the signal input from the analog speed/speed limit terminals (AD2 and GND, corresponding to pin 20 and pin 19) of the CN1 plug.

Application example:

1. Suppose analog input 2 functions is torque command.
2. The voltage of analog input 2 corresponds to the conversion gain of the motor torque command.
3. When P0.60 is set to “1” , this parameter is valid.
4. The relationship between the voltage of analog input 2 and torque command is as follows: The torque corresponding to every 1V voltage is 10% of the rated torque by default.

Actual torque command = Analog input voltage x P0.62

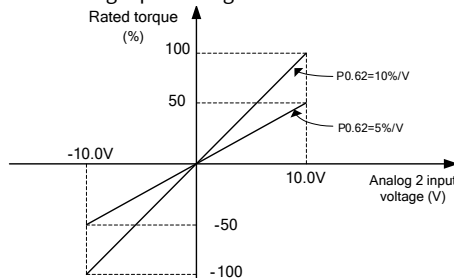

Note: Set this parameter according to the motor working condition. If this parameter is set to a large value, the motor speed may fluctuate sharply.

P0.62	Data size	32bit	Data format	DEC
	Modbus communication address	1124, 1125	CANopen communication address	0x203E, 0x00

P0.63	Reverse of AI 2	Setting range	Default	Unit	Applicable mode		
		0–1	0	-	P	S	T

This parameter specifies the voltage polarity of analog input 2.

	Set value	Actual detection result				
	[0]	Positive polarity	[+Voltage]→[Positive value], [-Voltage]→[Negative value]			
	1	Negative polarity	[+Voltage]→[Negative value], [-Voltage]→[Positive value]			
P0.63	Data size	16bit	Data format	DEC		
	Modbus communication address	1126, 1127	CANopen communication address	0x203F, 0x00		
P0.65	Dead zone of AI 2	Setting range	Default	Unit	Applicable mode	
		0.000–3.000	0.000	V	P	S
If the absolute voltage value of analog input 2 falls in the range of this parameter, the corresponding command value is 0.						
P0.65	Data size	16bit	Data format	DEC		
	Modbus communication address	1130, 1131	CANopen communication address	0x2041, 0x00		
P0.66	Internal torque command	Setting range	Default	Unit	Applicable mode	
		-500.0–500.0	0.0	%	-	-
This parameter specifies the internal torque reference. If the servo motor rated torque is considered as 100%, the setting of this parameter is a percentage of the servo motor rated torque.						
Note:						
<ul style="list-style-type: none"> • If the absolute value of this parameter is greater than maximum torque limit 1 (P0.10), the output torque is the setting value of P0.10 and the direction is the same as this parameter. • In torque mode, this parameter is valid only when P0.60 is 0. 						
P0.66	Data size	16bit	Data format	DEC		
	Modbus communication address	1132, 1133	CANopen communication address	0x2042, 0x00		
P0.67	Speed limit mode	Setting range	Default	Unit	Applicable mode	

		0-1	1	-	-	-	T
This parameter specifies the speed limit mode for torque control.							
	Set value	Designated method					
	0	The analog input is selected as the speed limit source. You need to set either P3.26 [Function of AI 1] or P3.27 [Function of AI 2] and P3.70 [Function of analog input 3] to 1 [Speed limit] and set associated parameters according to the actual situation.					
	[1]	Select the internal speed limit and anyone of P0.46-P0.49 may be selected.					

Note: The speed limit value is processed with absolute value internally. The actual sign of speed limit is the same with that of the torque command.

P0.67	Data size	16bit	Data format	DEC
	Modbus communication address	1134, 1135	CANopen communication address	0x2043, 0x00

P0.68	RAMP time of torque command	Setting range	Default	Unit	Applicable mode		
		0-10000	0	ms	-	-	T

This parameter is used to modify the planning curve when the torque command input changes. This parameter indicates the time taken to rise from 0 to 100% of the rated torque.

P0.68	Data size	16bit	Data format	DEC
	Modbus communication address	1136, 1137	CANopen communication address	0x2044, 0x00

P0.69	DEC time for quick stop	Setting range	Default	Unit	Applicable mode		
		0-10000	500	ms	P	S	T

This parameter specifies the DEC time for quick stop. It indicates the time taken to decelerate from 100% of the rated speed to 0.

P0.69	Data size	16bit	Data format	DEC
	Modbus communication address	1138, 1139	CANopen communication address	0x2045, 0x00

P0.70 ¹	Absolute encoder mode setting	Setting range	Default	Unit	Applicable mode		
		0-1	0	-	P	S	T

This parameter specifies the running mode of the multi-turn absolute encoder. Though the encoder working with the motor is a multi-turn absolute encoder, it is still considered as a single-turn encoder by default. If the multi-turn absolute function is needed, you need to prepare the spare battery for the encoder and set the work mode as the multi-turn absolute mode.

Set value	Designated method
[0]	Single-turn absolute value
1	Multi-turn absolute value

P0.70 ¹	Data size	16bit	Data format	DEC
	Modbus communication address	1140, 1141	CANopen communication address	0x2046, 0x00

P0.71*	Clear absolute encoder multiturn	Setting range	Default	Unit	Applicable mode		
		0-1	0	-	P	S	T

This parameter specifies whether to clear the multi-turn data for the multi-turn absolute encoder. If this function is enabled, the multi-turn data is cleared while the single-turn data remains unchanged, but the absolute position in the feedback is cleared.

 **Note:** If you use a multi-turn absolute encoder, after machinery installation, you can clear the absolute encoder after detecting the absolute zero position of the mechanic system at first power-on.

P0.71*	Data size	16bit	Data format	DEC
	Modbus communication address	1142, 1143	CANopen communication address	0x2047, 0x00

P0.72	Mechanical gear ratio (numerator) in absolute position rotary mode	Setting range	Default	Unit	Applicable mode		
		1-32767	1	-	P	S	T

This parameter specifies the mechanical gear ratio (numerator) in absolute position rotary mode.

P0.72	Data size	16bit	Data format	DEC
-------	-----------	-------	-------------	-----

	Modbus communication address	1144, 1145	CANopen communication address	0x2048, 0x00
--	------------------------------	------------	-------------------------------	--------------

P0.73	Mechanical gear ratio (denominator) in absolute position rotary mode	Setting range	Default	Unit	Applicable mode		
		1-32767	1	-	P	S	T

This parameter specifies the mechanical gear ratio (denominator) in absolute position rotary mode.

P0.73	Data size	16bit	Data format	DEC
	Modbus communication address	1146, 1147	CANopen communication address	0x2049, 0x00

P0.74	Number of pulses per revolution of the load side in absolute position rotary mode (Encoder unit-32 low-order bits)	Setting range	Default	Unit	Applicable mode		
		0-42949672 95	0	Encoder unit	P	S	T

This parameter specifies the number of pulses per revolution of the load side in absolute position rotary mode (Encoder unit-32 low-order bits).

P0.74	Data size	16bit	Data format	DEC
	Modbus communication address	1148, 1149	CANopen communication address	0x204A, 0x00

P0.75	Number of pulses per revolution of the load side in absolute position rotary mode (Encoder unit-32 high-order bits)	Setting range	Default	Unit	Applicable mode		
		0-42949672 95	0	Encoder unit	P	S	T

This parameter specifies the number of pulses per revolution of the load side in absolute position rotary mode (Encoder unit-32 high-order bits).

P0.75	Data size	16bit	Data format	DEC
	Modbus communication address	1150, 1151	CANopen communication address	0x204B, 0x00

9.1.4 Control mode switchover

P0.90	Max. speed limit of control mode switching	Setting range	Default	Unit	Applicable mode		
		1-1000	100	r/min	P	S	T
This parameter specifies the maximum running speed during positioning for switching from the speed or torque mode to the position mode when the hybrid of position and speed or the hybrid of position and torque is used.							
P0.90	Data size	16bit	Data format	DEC			
	Modbus communication address	1180, 1181	CANopen communication address	0x205A, 0x00			

P0.91	Positioning reference of control mode switching	Setting range	Default	Unit	Applicable mode		
		-1-(2 ³¹ -1)	-1	pulse	P	S	T
This parameter specifies the motor position R0.14 [Rotor position relative to pulse Z] after the control mode is switched. The switching is made from the speed or torque mode to the position mode when the hybrid of position and speed or the hybrid of position and torque is used.							
Note: <ul style="list-style-type: none"> After the control mode switching, the reference point in the received position command is the setting of this parameter. The unit of this parameter is the encoder pulse unit. If this parameter is set to -1 and the control mode needs to switch from speed mode to position mode, switching is executed at the current position, without positioning to the reference point. If the mechanical angle corresponding to the setting of P3.50 is less than or equal to 0.5°, the positioning is accurate to ±P3.50. If the mechanical angle is greater than 0.5°, the positioning is accurate to the pulse number corresponding to ±0.5°. 							
P0.91	Data size	32bit	Data format	DEC			
	Modbus communication address	1182, 1183	CANopen communication address	0x205B, 0x00			

P0.92	Position mode switching exit mode	Setting range	Default	Unit	Applicable mode		
		0-1	0	-	P	S	T
When P0.03 is 3 or 4, this parameter is used to set the exiting mode when the position mode							

can be switched to other control modes.

	Set value	Exiting mode		
	[0]	The position mode is switched to another mode after positioning is complete.		
	1	The position mode is immediately switched to another mode when the control mode switching command is invalid.		

P0.92	Data size	16bit	Data format	DEC
	Modbus communication address	1184, 1185	CANopen communication address	0x205C, 0x00

P0.93	Exit mode for switching from speed or torque mode	Setting range	Default	Unit	Applicable mode		
		0-1	1	-	P	S	T

This parameter specifies the exit mode for switching from speed or torque mode to the position mode when the hybrid of position and speed or the hybrid of position and torque is used. When P0.93 is set to 0, it is switching after decelerating to zero, and when P0.93 is set to 1, it is switching immediately.

P0.93	Data size	16bit	Data format	DEC
	Modbus communication address	1186, 1187	CANopen communication address	0x205D, 0x00

9.1.5 Speed display filtering

P0.99	Speed detection FIR filtering class	Setting range	Default	Unit	Applicable mode		
		1-31	1	-	P	S	T

This parameter specifies the FIR filter level displayed by R0.00 [motor speed]. When P0.99 is 1 by default, there is no filter, and the larger the setting value, the smoother the speed display.

P0.99	Data size	16bit	Data format	DEC
	Modbus communication address	1198, 1199	CANopen communication address	0x2063, 0x00

9.2 Autotuning control (Group P1 parameters)

9.2.1 Inertia identification (Automatic gain)

P1.00	Tune inertia online	Setting range	Default	Unit	Applicable mode		
		0-1	0	-	P	S	T

This parameter specifies whether to automatically tune inertia online and adjust the gain.

Set value	Meaning
[0]	Online inertia identifying is invalid.
1	Online inertia identifying is valid.

P1.00	Data size	16bit	Data format	DEC
	Modbus communication address	1200, 1201	CANopen communication address	0x2100, 0x00

P1.01	Inertia ratio 1	Setting range	Default	Unit	Applicable mode		
		0-10000	250	%	P	S	T

Rotation inertia ratio = Load inertia/Motor rotation inertia x 100%

If P1.01 is set correctly, the setting unit of P2.00 and P2.05 is Hz.

If P1.01 is greater than the actual value, the speed loop gain unit will increase, and if it is smaller than the actual value, the speed loop gain unit will decrease.

If online automatic tuning is valid, the inertia ratio is updated to P1.01 in real time and written to the EEPROM every 30 minutes.

P1.01	Data size	16bit	Data format	DEC
	Modbus communication address	1202, 1203	CANopen communication address	0x2101, 0x00

P1.02	Inertia ratio 2	Setting range	Default	Unit	Applicable mode		
		0-10000	250	%	P	S	T

The meaning of P1.02 is similar to that of P1.01.

 **Note:** Automatic online gain adjusting is invalid for this parameter.

P1.02	Data size	16bit	Data format	DEC
	Modbus communication address	1204, 1205	CANopen communication address	0x2102, 0x00

	address		address	
--	---------	--	---------	--

P1.03	Machine rigidity setting	Setting range	Default	Unit	Applicable mode		
		0-31	13	-	P	S	T

A greater mechanical rigidity value indicates quicker response and high rigidity performance, but it increases the possibility to cause vibration. In stable working condition, you can set a greater value to obtain quicker response.

Mechanical structure	Rigidity setting
Large transfer or transmission equipment	0-13
Belt drive mechanism	5-16
Ball screw + belt drive	5-16
Manipulator	15-22
Direct ball screw or rigid body	18-25

P1.03	Data size	16bit	Data format	DEC
	Modbus communication address	1206, 1207	CANopen communication address	0x2103, 0x00

P1.04*	Tune inertia offline	Setting range	Default	Unit	Applicable mode		
		0-1	0	-	P	S	T

This parameter is used to obtain the load inertial ratio of the motor rotation inertia. After inertia identifying is enabled, the motor runs six cycles to identify inertia. In each cycle, the motor runs at the mode specified by P1.05 [Inertia identifying mode]. The maximum rotation number of the motor is determined by P1.06 [Max. rotations by inertia identifying], and the ACC command time is determined by P1.07 [ACC time for inertia identifying].

Set value	Function
[0]	Disable inertia identifying
1	Enable inertia identifying

Note:

- The motor speed is fast during identifying if P1.06 and P1.07 are set to great values.
- If the drive reports the alarm Er25-7 during identifying, see section [10.2 Drive faults and solutions](#) to handle it.
- This parameter is invalid when the servo is enabled.

P1.04*	Data size	16bit	Data format	DEC
--------	-----------	-------	-------------	-----

	Modbus communication address	1208, 1209	CANopen communication address	0x2104, 0x00
--	------------------------------	------------	-------------------------------	--------------

P1.05	Operation mode of inertia identification	Setting range	Default	Unit	Applicable mode		
		0-3	0	-	P	S	T

This parameter is used to set the operation mode of inertia identification.

Set value	Function
[0]	Forward rotation and then reverse rotation
1	Forward rotation
2	Reverse rotation
3	Reverse rotation and then forward rotation

P1.05	Data size	16bit	Data format	DEC
	Modbus communication address	1210, 1211	CANopen communication address	0x2105, 0x00

P1.06	Movable range of inertia identification	Setting range	Default	Unit	Applicable mode		
		0.2-20.0	2.0	r	P	S	T

If the inertia identification mode is valid and specified in position mode, this parameter is used to limit the maximum rotation number of the motor in each cycle.

P1.06	Data size	16bit	Data format	DEC
	Modbus communication address	1212, 1213	CANopen communication address	0x2106, 0x00

P1.07	ACC time constant of inertia identification	Setting range	Default	Unit	Applicable mode		
		2-1000	200	ms	P	S	T

This parameter is used to set the motor ACC time during the inertia identification. If the load inertia is heavy, the ACC time can be set to a greater value, preventing overload alarms.

P1.07	Data size	16bit	Data format	DEC
	Modbus communication address	1214, 1215	CANopen communication address	0x2107, 0x00

P1.08	Speed level of inertia identification	Setting range	Default	Unit	Applicable mode																	
		0-3	1	-	P	S	T															
<p>This parameter is used to set the speed level of inertia identification. A large value of this parameter indicates a quick response to the load characteristic changes, resulting in large fluctuation of the presumption value. The presumption result is saved every 30 minutes.</p> <table border="1"> <thead> <tr> <th>Set value</th> <th>Function</th> <th>Meaning</th> </tr> </thead> <tbody> <tr> <td>0</td> <td>No change</td> <td>Stop the presumption of load characteristics.</td> </tr> <tr> <td>[1]</td> <td>No major change</td> <td>There is no major change to load characteristics.</td> </tr> <tr> <td>2</td> <td>Slow change</td> <td>Load characteristics change slowly.</td> </tr> <tr> <td>3</td> <td>Sharp change</td> <td>Load characteristics change sharply.</td> </tr> </tbody> </table>								Set value	Function	Meaning	0	No change	Stop the presumption of load characteristics.	[1]	No major change	There is no major change to load characteristics.	2	Slow change	Load characteristics change slowly.	3	Sharp change	Load characteristics change sharply.
Set value	Function	Meaning																				
0	No change	Stop the presumption of load characteristics.																				
[1]	No major change	There is no major change to load characteristics.																				
2	Slow change	Load characteristics change slowly.																				
3	Sharp change	Load characteristics change sharply.																				
P1.08	Data size	16bit	Data format	DEC																		
	Modbus communication address	1216, 1217	CANopen communication address	0x2108, 0x00																		

9.2.2 Self-adaptive vibration control

P1.19	Resonance detection sensitivity	Setting range	Default	Unit	Applicable mode		
		0.2-100.0	5.0	%	P	S	T
<p>This parameter is used to set the sensitivity of the automatic detection on mechanical resonance frequency. A smaller value of this parameter indicates higher sensitivity to the resonance.</p> <p> Note: When the set value of P1.19 is increasing, the sensitivity to the resonance is reducing.</p>							
P1.19	Data size	16bit	Data format	DEC			
	Modbus communication address	1238, 1239	CANopen communication address	0x2113, 0x00			

P1.20	Resonance detection mode	Setting range	Default	Unit	Applicable mode		
		0-7	0	-	P	S	T
<p>This parameter is used to set the working mode of resonance detection, resonant frequency presumed by the self-adaptive notch filter, and action after presumption.</p> <p>If the function of automatically detecting the mechanical resonant frequency is valid (that is, this parameter is set to 1, 2, or 3), the system automatically collects data to conduct mechanical resonant frequency analysis and saves results to P1.21 and P1.22. You can set the notch filter frequency according to the settings of P1.21 and P1.22 to eliminate the mechanical resonance.</p> <p>Note: You are recommended to disable the function after the gain adjustment is complete.</p>							
Set value	Function	Meaning					
[0]	Invalid	All parameters associated with the notch filter remain unchanged.					
1	One notch filter valid	The parameters associated with the third notch filter are updated according to the self-adaptive result.					
2	Two notch filters valid	The parameters related to the third and fourth notch filters are updated according to the self-adaptive result.					
3	Resonant frequency test mode	The mechanical resonant frequency is detected automatically but the parameters associated with notch filters are not set.					
4	Clearing notch filter parameters	The parameters associated with the four notch filters are restored to the default values.					
5	Notch filter 3 → Notch filter 1	The parameters of the third notch filter to are automatically copied to the first notch filter and then restored to the default values.					
6	Notch filter 4 → Notch filter 2	The parameters of the fourth notch filter to are automatically copied to the first notch filter and then restored to the default values.					
7	Notch filters 3 and 4 → Notch filters 1 and 2	The parameters of the third and fourth notch filters to are automatically copied to the first and second notch filters and then restored to the default values.					
P1.20	Data size	16bit	Data format	DEC			
	Modbus communication	1240, 1241	CANopen communication	0x2114, 0x00			

		address			address			
P1.21*	Mechanical resonant frequency 1	Setting range	Default	Unit	Applicable mode			
		0-5000	5000	Hz	P	S	T	
P1.22*	Mechanical resonant frequency 2	Setting range	Default	Unit	Applicable mode			
		0-5000	5000	Hz	P	S	T	
<p>This group of parameter displays mechanical resonant frequency. When P1.20 is set to 1, indicating mechanical resonance frequency detection is valid, the system detects the frequency of the max. resonance point and displays it by function codes.</p> <p>Note:</p> <ul style="list-style-type: none"> The measurement results are accurate only when the rotation speed reaches 30 r/min at least. This function is read only. You can set the notch filter frequency through this group of parameter to eliminate mechanical resonance. The value 5000 indicates no resonance point is found. 								
P1.21	Data size	16bit	Data format	DEC				
	Modbus communication address	1242, 1243	CANopen communication address	0x2115, 0x00				
P1.22	Data size	16bit	Data format	DEC				
	Modbus communication address	1244, 1245	CANopen communication address	0x2116, 0x00				
P1.23	Frequency of notch filter 1	Setting range	Default	Unit	Applicable mode			
		50-5000	5000	Hz	P	S	T	
<p>This parameter is used to set the frequency of notch filter 1 for suppressing resonance. The notch filter can simulate the mechanical resonant frequency, thus suppressing the resonant frequency.</p> <p>The value 5000 indicates the notch filter function is invalid.</p>								
P1.23	Data size	16bit	Data format	DEC				
	Modbus communication address	1246, 1247	CANopen communication address	0x2117, 0x00				

P1.24	Q factor of notch filter 1	Setting range	Default	Unit	Applicable mode		
		0.50-16.00	1.00	-	P	S	T
<p>This parameter is used to set the Q value (quality factor) of notch filter 1. Q factor of notch filter = Center frequency of notch filter/Bandwidth of notch filter Generally, the default value is kept.</p>							
P1.24	Data size	16bit	Data format	DEC			
	Modbus communication address	1248, 1249	CANopen communication address	0x2118, 0x00			
P1.25	Depth of notch filter 1	Setting range	Default	Unit	Applicable mode		
		0-100	0	%	P	S	T
<p>This parameter is used to the amplitude attenuation rate of notch filter 1. A large value of this parameter indicates low notch filter depth and small phase lag.</p>							
P1.25	Data size	16bit	Data format	DEC			
	Modbus communication address	1250, 1251	CANopen communication address	0x2119, 0x00			
P1.26	Frequency of notch filter 2	Setting range	Default	Unit	Applicable mode		
		50-5000	5000	Hz	P	S	T
P1.27	Q factor of notch filter 2	Setting range	Default	Unit	Applicable mode		
		0.50-16.00	1.00	-	P	S	T
P1.28	Depth of notch filter 2	Setting range	Default	Unit	Applicable mode		
		0-100	0	%	P	S	T
<p>These parameters are used to set characteristics of notch filter 2, similar to P1.23, P1.24, and P1.25.</p>							
P1.26	Data size	16bit	Data format	DEC			
	Modbus communication address	1252, 1253	CANopen communication address	0x211A, 0x00			
P1.27	Data size	16bit	Data format	DEC			

	Modbus communication address	1254, 1255	CANopen communication address	0x211B, 0x00
P1.28	Data size	16bit	Data format	DEC
	Modbus communication address	1256, 1257	CANopen communication address	0x211C, 0x00

P1.29	Frequency of notch filter 3	Setting range	Default	Unit	Applicable mode		
		50-5000	5000	Hz	P	S	T
P1.30	Q factor of notch filter 3	Setting range	Default	Unit	Applicable mode		
		0.50-16.00	1.00	-	P	S	T
P1.31	Depth of notch filter 3	Setting range	Default	Unit	Applicable mode		
		0-100	0	%	P	S	T

These parameters are used to set characteristics of notch filter 3, similar to P1.23, P1.24, and P1.25.

P1.29	Data size	16bit	Data format	DEC
	Modbus communication address	1258, 1259	CANopen communication address	0x211D, 0x00
P1.30	Data size	16bit	Data format	DEC
	Modbus communication address	1260, 1261	CANopen communication address	0x211E, 0x00
P1.31	Data size	16bit	Data format	DEC
	Modbus communication address	1262, 1263	CANopen communication address	0x211F, 0x00

P1.32	Frequency of notch filter 4	Setting range	Default	Unit	Applicable mode		
		50-5000	5000	Hz	P	S	T
P1.33	Q factor of notch filter 4	Setting range	Default	Unit	Applicable mode		

		0.50-16.00	1.00	-	P	S	T
P1.34	Depth of notch filter 4	Setting range	Default	Unit	Applicable mode		
		0-100	0	%	P	S	T

These parameters are used to set characteristics of notch filter 4, similar to P1.23, P1.24, and P1.25.

P1.32	Data size	16bit	Data format	DEC
	Modbus communication address	1264, 1265	CANopen communication address	0x2120, 0x00
P1.33	Data size	16bit	Data format	DEC
	Modbus communication address	1266, 1267	CANopen communication address	0x2121, 0x00
P1.34	Data size	16bit	Data format	DEC
	Modbus communication address	1268, 1269	CANopen communication address	0x2122, 0x00

P1.35	Vibration control mode in position command	Setting range	Default	Unit	Applicable mode		
		0-2	0	-	P	-	-

This parameter is used to set the switching mode of the filter used for vibration control.

Set value	Function
[0]	Vibration control by filter 1 is valid.
1	Filter 1 and filter 2 are switched according to VS-SEL.
2	Automatic

Note: If a digital input terminal is used for selection, one of parameters P3.00-P3.09 must be set to 0x11C or 0x01C (according to VS-SEL).

Relationship with COM+

0: OFF (The internal optical coupler corresponding to the input is not conducted.)

1: ON (The internal optical coupler corresponding to the input is conducted.)

P1.35	Data size	16bit	Data format	DEC
	Modbus communication address	1270, 1271	CANopen communication address	0x2123, 0x00

P1.36	Vibration control frequency 1	Setting range	Default	Unit	Applicable mode		
		0.0–200.0	0.0	Hz	P	-	-
<p>This parameter is used to set the frequency point at which the vibration at the load peak is suppressed.</p> <p> Note: The set frequency must range from 1.0 Hz to 200.0 Hz. It is invalid if the setting value is below 1.0Hz.</p>							
P1.36	Data size	16bit	Data format	DEC			
	Modbus communication address	1272, 1273	CANopen communication address	0x2124, 0x00			
P1.37	Coefficient of vibration control filter 1	Setting range	Default	Unit	Applicable mode		
		0.00–1.00	1.00	-	P	-	-
<p>This parameter is used to set the coefficient of the first vibration control filter.</p>							
P1.37	Data size	16bit	Data format	DEC			
	Modbus communication address	1274, 1275	CANopen communication address	0x2125, 0x00			
P1.38	Vibration control frequency 2	Setting range	Default	Unit	Applicable mode		
		0.0–200.0	0.0	Hz	P	-	-
P1.39	Coefficient of vibration control filter 2	Setting range	Default	Unit	Applicable mode		
		0.00–1.00	1.00	-	P	-	-
<p>These parameters are used to set characteristics of the second vibration control filter, similar to P1.36 and P1.37.</p>							
P1.38	Data size	16bit	Data format	DEC			
	Modbus communication address	1276, 1277	CANopen communication address	0x2126, 0x00			
P1.39	Data size	16bit	Data format	DEC			
	Modbus communication address	1278, 1279	CANopen communication address	0x2127, 0x00			

9.3 Motor control parameters (Group P2 parameters)

9.3.1 Gain setting

P2.00	First speed gain	Setting range	Default	Unit	Applicable mode		
		0.0–3276.7	27.0	Hz	P	S	T

The speed loop responsiveness of the servo system is determined by the speed gain. Increasing this parameter improves the speed response, but it increases the possibility to cause vibration and noise.

 **Note:** If the inertia ratio is set correctly, the unit of P2.00 is Hz.

P2.00	Data size	16bit	Data format	DEC
	Modbus communication address	1400, 1401	CANopen communication address	0x2200, 0x00

P2.01	First speed integral time constant	Setting range	Default	Unit	Applicable mode		
		0.1–1000.0	21.0	ms	P	S	T

This parameter is used to set the integral time constant of the speed loop. A smaller value of this parameter indicates quicker response, but it increases the possibility to cause vibration and noise.

It should be noted particularly that when this parameter is set to 1000, it means the integral action is invalid.

P2.01	Data size	16bit	Data format	DEC
	Modbus communication address	1402, 1403	CANopen communication address	0x2201, 0x00

P2.02	First position gain	Setting range	Default	Unit	Applicable mode		
		0.0–3276.7	48.0	1/s	P	-	-

The position loop responsiveness of the servo system is determined by the position gain. A smaller value of this parameter indicates quicker response, but it increases the possibility to cause vibration and noise.

P2.02	Data size	16bit	Data format	DEC
	Modbus communication address	1404, 1405	CANopen communication address	0x2202, 0x00

P2.03	First speed detection filter	Setting range	Default	Unit	Applicable mode		
		100-5000	5000	Hz	P	S	T
This parameter is used to set the first speed detection filter. Note: The value 5000 indicates no filtering. A smaller value of this parameter indicates lower motor noise and speed fluctuation, but it slows down the responsiveness.							
P2.03	Data size	16bit	Data format		DEC		
	Modbus communication address	1406, 1407	CANopen communication address		0x2203, 0x00		

P2.04	First torque filter	Setting range	Default	Unit	Applicable mode		
		0.00-25.00	0.84	ms	P	S	T
This parameter is used to set the time constant of the torque filter.							
P2.04	Data size	16bit	Data format		DEC		
	Modbus communication address	1408, 1409	CANopen communication address		0x2204, 0x00		

P2.05	Second speed gain	Setting range	Default	Unit	Applicable mode		
		0.0-3276.7	27.0	Hz	P	S	T
P2.06	Second speed integral time constant	Setting range	Default	Unit	Applicable mode		
		0.1-1000.0	1000.0	ms	P	S	T
P2.07	Second position gain	Setting range	Default	Unit	Applicable mode		
		0.0-3276.7	57.0	1/s	P	-	-
P2.08	Second speed detection filter	Setting range	Default	Unit	Applicable mode		
		100-5000	5000	Hz	P	S	T
P2.09	Second torque filter	Setting range	Default	Unit	Applicable mode		
		0.00-25.00	0.84	ms	P	S	T
There are two groups of parameters respectively for position gain, speed gain, speed integral time constant, speed detection filter, and torque filter. The definition of the function and content are the same with those of the first group.							

You can select or switch between the first gain and the second gain as needed. See the descriptions for P2.20–P2.34.

P2.05	Data size	16bit	Data format	DEC
	Modbus communication address	1410, 1411	CANopen communication address	0x2205, 0x00
P2.06	Data size	16bit	Data format	DEC
	Modbus communication address	1412, 1413	CANopen communication address	0x2206, 0x00
P2.07	Data size	16bit	Data format	DEC
	Modbus communication address	1414, 1415	CANopen communication address	0x2207, 0x00
P2.08	Data size	16bit	Data format	DEC
	Modbus communication address	1416, 1417	CANopen communication address	0x2208, 0x00
P2.09	Data size	16bit	Data format	DEC
	Modbus communication address	1418, 1419	CANopen communication address	0x2209, 0x00

P2.10	Speed feed-forward gain	Setting range	Default	Unit	Applicable mode		
		0.0–100.0	0.0	%	P	-	-

This parameter is used to set the speed feed-forward gain. If it is set to 100%, residual pulses are almost zero when the motor runs at a stable speed, but overshooting increases at sudden ACC/DEC.

P2.10	Data size	16bit	Data format	DEC
	Modbus communication address	1420, 1421	CANopen communication address	0x220A, 0x00

P2.11	Speed feed-forward filter time	Setting range	Default	Unit	Applicable mode		
		0.00–64.00	0.50	ms	P	-	-

This parameter is used to set the speed feed-forward filter time.

P2.11	Data size	16bit	Data format	DEC
	Modbus	1422, 1423	CANopen	0x220B, 0x00

	communication address		communication address	
--	-----------------------	--	-----------------------	--

P2.12	Torque feed-forward gain	Setting range	Default	Unit	Applicable mode		
		0.0–200.0	0.0	%	P	S	-

This parameter is used to set the torque feed-forward gain. After the torque is calculated according to the speed control command, the torque multiplied by the setting of this parameter is added to the torque command from speed control.

Increasing the torque feed-forward gain can improve response performance in ACC/DEC and reduce position deviation.

P2.12	Data size	16bit	Data format	DEC
	Modbus communication address	1424, 1425	CANopen communication address	0x220C, 0x00

P2.13	Torque feed-forward filter time	Setting range	Default	Unit	Applicable mode		
		0.00–64.00	0.00	ms	P	S	-

This parameter is used to set the torque feed-forward filter time.

P2.13	Data size	16bit	Data format	DEC
	Modbus communication address	1426, 1427	CANopen communication address	0x220D, 0x00

P2.14	First IPPI coefficient	Setting range	Default	Unit	Applicable mode		
		0–1000	100	%	P	S	T

This parameter is used to set the first IPPI coefficient.

 **Note:** IP control is applied when it is set to 0, while PI control is applied when it is set to 100.

P2.14	Data size	16bit	Data format	DEC
	Modbus communication address	1428, 1429	CANopen communication address	0x220E, 0x00

P2.15	Second IPPI coefficient	Setting range	Default	Unit	Applicable mode		
		0–1000	100	%	P	S	T

This parameter is used to set the second IPPI coefficient.

Note: IP control is applied when it is set to 0, while PI control is applied when it is set to 100.

P2.15	Data size	16bit	Data format	DEC
	Modbus communication address	1430, 1431	CANopen communication address	0x220F, 0x00

9.3.2 Gain switchover

P2.20	Second gain setting	Setting range	Default	Unit	Applicable mode		
		0-1	1	-	P	S	T

This parameter specifies the proper adjustment for gain switching.

Set value	Exiting mode
0	First gain is fixed. The speed loop action is switched to the PI or P action based on the gain switching input (that is, the digital input is configured as function gain switching, corresponding to 0x006) or P4.16 [Gain switching command]. Gain switching invalid → PI action Gain switching valid → P action Note: 0x006 is valid when the digital inputs a low electrical level, while 0x106 is valid when the digital inputs a high electrical level.
[1]	Switching between the first gain [P2.00-P2.04] and the second gain [P2.05-P2.09] is valid.

P2.20	Data size	16bit	Data format	DEC
	Modbus communication address	1440, 1441	CANopen communication address	0x2214, 0x00

P2.22	Switching trigger in position control	Setting range	Default	Unit	Applicable mode		
		0-9	0	-	P	-	-

This parameter is used to set the trigger condition of gain switching in position control or fully-closed loop control.

Set value	Switching condition	Gain switching condition
[0]	First gain fixed	Be fixed in the first gain [P2.00-P2.04]
1	Second gain	Be fixed in the second gain [P2.05-P2.09]

	fixed	
2	Switching input with gain	Invalid: First gain Valid: Second gain
3	Large torque command	In the previous first gain, if the absolute value of torque command exceed (level+delay) [0.1%], it will switch to the second gain. In the previous second gain, if the absolute value of torque command keeps below (level-delay) [0.1%] in the delay time, it will return to the first gain.
4	Large speed command	In the previous first gain, if the absolute value of speed command exceed (level+delay) [r/min], it will switch to the second gain. In the previous second gain, if the absolute value of speed command keeps below (level-delay) [r/min] in the delay time, it will return to the first gain.
5	Large position deviation	In the previous first gain, if the absolute value of position deviation exceed (level+delay) [pulse], it will switch to the second gain. In the previous second gain, if the absolute value of position deviation keeps below (level-delay) [pulse] in the delay time, it will return to the first gain.  Note: The unit of level and lag [pulse] acts as encoder resolution unit during position control and as linear encoder resolution unit during fully-closed loop control.
6	With position command	In the previous first gain, if the position command is not 0, it will switch to the second gain. In the previous second gain, if the 0 position command lasts in the delay time, it will return to the first gain.
7	Positioning not finished	In the previous first gain, if the positioning is not finished, it will switch to the second gain. In the previous second gain, if the state of positioning finished lasts in the delay time, it will return to the first gain.
8	Large actual speed	In the previous first gain, if the absolute value of the actual speed exceed (level+delay) [r/min], it will switch to the second gain. In the previous second gain, if the absolute value of the actual speed keeps below (level-delay) [r/min] and such state in the delay time, it will return to the first gain.
9	With position command+	In the previous first gain, if the position command is not 0, it will switch to second gain.

		actual speed	In the previous second gain, if the 0 position command lasts in the delay time and the absolute value of actual speed is below (level-delay) [r/min], it will return to the first gain.		
P2.22	Data size	16bit	Data format	DEC	
	Modbus communication address	1444, 1445	CANopen communication address	0x2216, 0x00	

P2.23	Switching delay in position control	Setting range	Default	Unit	Applicable mode	
		0-10000	0	ms	P	-

In the position control, if set P2.22 to 3-9, when switching from the second gain to the first gain, it is the time from meeting the trigger conditions to the actual switching.

P2.23	Data size	16bit	Data format	DEC	
	Modbus communication address	1446, 1447	CANopen communication address	0x2217, 0x00	

P2.24	Switching level in position control	Setting range	Default	Unit	Applicable mode	
		0-20000	0	Based on mode	P	-

In the position control, if set P2.22 to 3-5, 8, 9, it is necessary to set triggering condition of gain switching. The unit will vary with the switching mode and setting.

Note: Please set the level ≥ the delay

P2.24	Data size	16bit	Data format	DEC	
	Modbus communication address	1448, 1449	CANopen communication address	0x2218, 0x00	

P2.25	Switching delay in position control	Setting range	Default	Unit	Applicable mode	
		0-20000	0	Based on mode	P	-

In the position control, if set P2.22 to 3-5, 8, 9, it is necessary to set switching conditions. The unit will vary with the switching mode and setting.

Note: Set the level < the delay, in the actual internal application, the delay = the level

P2.25	Data size	16bit	Data format	DEC	
	Modbus	1450, 1451	CANopen	0x2219, 0x00	

	communication address		communication address	
--	--------------------------	--	--------------------------	--

P2.26	Position gain switching time	Setting range	Default	Unit	Applicable mode		
		0-10000	0	ms	P	-	-

In position control, if the difference between P2.00 and P2.04 is great, you can set this parameter to control the torque change and vibration caused by the switching from the small gain to the large gain at the current position. This parameter is invalid when the position gain is switched from a large value to a small one, and the switching takes effect immediately.

P2.26	Data size	16bit	Data format	DEC
	Modbus communication address	1452, 1453	CANopen communication address	0x221A, 0x00

P2.27	Switching mode of speed control	Setting range	Default	Unit	Applicable mode		
		0-5	0	-	-	S	-

The trigger conditions of gain switching during speed control are as below:

Set value	Switching condition	Gain switching condition
[0]	First gain fixed	Be fixed in the first gain [P2.00-P2.04]
1	Second gain fixed	Be fixed in the second gain [P2.05, P2.06, P2.08, P2.09]
2	Switching input with gain	Invalid: First gain Valid: Second gain
3	Torque command	In the previous first gain, if the absolute value of torque command exceed (level+delay) [0.1%], it will switch to the second gain. In the previous second gain, if the absolute value of torque command keeps below (level-delay) [0.1%] in the delay time, it will return to the first gain.
4	Speed command variable	In previous first gain, if the absolute value of speed command variable exceed (level+delay) [10r/min/s], it will switch to the second gain. In the previous second gain, if the absolute value of the speed command variable keeps below (level-delay) [10r/min/s] in the delay time, it will return to the first gain.

5	Velocity	<p>In the previous first gain, if the absolute value of speed command exceed (level+delay) [r/min], it will switch to the second gain.</p> <p>In the previous second gain, if the absolute value of speed command keeps below (level-delay) [r/min] in the delay time, it will return to the first gain.</p>
---	----------	--

Note: The parameter is invalid for the position gain. The actual position gain is always the first gain.

P2.27	Data size	16bit	Data format	DEC
	Modbus communication address	1454, 1455	CANopen communication address	0x221B, 0x00

P2.28	Switching delay in position control	Setting range	Default	Unit	Applicable mode		
		0-10000	0	ms	-	S	-

In the speed control, if set P2.27 to 3-5, when switching from the second gain to the first gain, it is the time from meeting the trigger conditions to the actual switching.

P2.28	Data size	16bit	Data format	DEC
	Modbus communication address	1456, 1457	CANopen communication address	0x221C, 0x00

P2.29	Switching level of speed control	Setting range	Default	Unit	Applicable mode		
		0-20000	0	Based on mode	-	S	-

In the speed control, if set P2.27 to 3-5, it is necessary to set triggering condition of gain switching. The unit will vary with the switching mode and setting.

Note: Please set the level \geq the delay

P2.29	Data size	16bit	Data format	DEC
	Modbus communication address	1458, 1459	CANopen communication address	0x221D, 0x00

P2.30	Switching delay in speed control	Setting range	Default	Unit	Applicable mode		
		0-20000	0	Based on mode	-	S	-

In the speed control, if set P2.27 to 3-5, it is necessary to set switching conditions. The unit will vary with the switching mode and setting.

Note: Set the level<the delay, in the actual internal application, the delay=the level

P2.30	Data size	16bit	Data format	DEC
	Modbus communication address	1460, 1461	CANopen communication address	0x221E, 0x00

P2.31	Switching mode of torque control	Setting range	Default	Unit	Applicable mode		
		0-3	0	-	-	-	T

The trigger conditions of gain switching during torque control are as below:

Set value	Switching condition	Gain switching condition
[0]	First gain fixed	Be fixed in the first gain [P2.00-P2.04]
1	Second gain fixed	Be fixed in the second gain [P2.05, P2.06, P2.08, P2.09]
2	Switching input with gain	Invalid: First gain Valid: Second gain
3	Torque command	In the previous first gain, if the absolute value of torque command exceed (level+delay) [0.1%], it will switch to the second gain. In the previous second gain, if the absolute value of torque command keeps below (level-delay) [0.1%] in the delay time, it will return to the first gain.

Note: The parameter is invalid for the position gain. The actual position gain is always the first gain.

P2.31	Data size	16bit	Data format	DEC
	Modbus communication address	1462, 1463	CANopen communication address	0x221F, 0x00

P2.32	Switching delay in torque control	Setting range	Default	Unit	Applicable mode		
		0-10000	0	ms	-	-	T

In the torque control, if set P2.31 to 3, when switching from the second gain to the first gain, it is the time from meeting the trigger conditions to the actual switching.

P2.32	Data size	16bit	Data format	DEC
	Modbus	1464, 1465	CANopen	0x2220, 0x00

	communication address		communication address	
--	-----------------------	--	-----------------------	--

P2.33	Switching level of torque control	Setting range	Default	Unit	Applicable mode		
		0-20000	0	Based on mode	-	-	T

In the torque control, if set P2.31 to 3, it is necessary to set triggering condition of gain switching. The unit will vary with the switching mode and setting.

Note: Please set the level \geq the delay

P2.33	Data size	16bit	Data format	DEC
	Modbus communication address	1466, 1467	CANopen communication address	0x2221, 0x00

P2.34	Switching delay in torque control	Setting range	Default	Unit	Applicable mode		
		0-20000	0	Based on mode	-	-	T

In the torque control, if set P2.31 to 3, it is necessary to set switching condition. The unit will vary with the switching mode and setting.

Note: Set the level < the delay, in the actual internal application, the delay = the level

P2.34	Data size	16bit	Data format	DEC
	Modbus communication address	1468, 1469	CANopen communication address	0x2222, 0x00

9.3.3 Special motor control

P2.41 ²	Disturbance observer	Setting range	Default	Unit	Applicable mode		
		0-2	0	-	P	S	T

This parameter specifies whether the disturbance observer is valid.

Set value	Function
[0]	Invalid
1	Disturbance observation
2	Disturbance compensation

P2.41 ²	Data size	16bit	Data format	DEC
	Modbus	1482, 1483	CANopen	0x2229, 0x00

	communication address		communication address				
P2.42	Disturbance observer compensation gain	Setting range	Default	Unit	Applicable mode		
		0-100	0	%	P	S	-
<p>This parameter specifies the compensation gain for disturbance torque. This parameter is used to set the compensation gain of disturbance torque. Increasing the gain may improve the effect of suppressing disturbance impact but the noise may enhanced. This parameter needs to be used with P2.43 to find the best setting point. After setting P2.43, please increase the set value of P2.42.</p>							
P2.42	Data size	16bit	Data format	DEC			
	Modbus communication address	1484, 1485	CANopen communication address	0x222A, 0x00			
P2.43	Disturbance observer cut-off frequency	Setting range	Default	Unit	Applicable mode		
		0-3000	200	Hz	P	S	-
<p>This parameter is used to set the cut-off frequency of disturbance observer. Decreasing the set value can downgrade the noise, while increasing the setting may decrease the disturbance torque compensation delay. This parameter needs to be used with P2.42.</p>							
P2.43	Data size	16bit	Data format	DEC			
	Modbus communication address	1486, 1487	CANopen communication address	0x222B, 0x00			
P2.44	Torque command offset	Setting range	Default	Unit	Applicable mode		
		-500.0-500.0	0.0	%	P	S	T
<p>This parameter is used to set the changeable load compensation which is added to the torque command. It is usually be used in the vertical shaft application scenario, which excludes the torque control mode.</p>							
P2.44	Data size	16bit	Data format	DEC			
	Modbus communication address	1488, 1489	CANopen communication address	0x222C, 0x00			

P2.50 ²	Fully-closed loop vibration suppressor	Setting range	Default	Unit	Applicable mode		
		0-2	0	-	-	-	-
This parameter specifies whether the speed observer is valid.							
		Set value	Function				
		[0]	Invalid				
		1	Disturbance observation				
		2	Disturbance compensation				
P2.50 ²	Data size	16bit	Data format	DEC			
	Modbus communication address	1500, 1501	CANopen communication address	0x2232, 0x00			

P2.51	Fully-closed loop vibration suppressor cut-off frequency	Setting range	Default	Unit	Applicable mode		
		1.0-500.0	100.0	Hz	-	-	-
This parameter is used to set the cut-off frequency of fully-closed loop vibration suppressor.							
P2.51	Data size	16bit	Data format	DEC			
	Modbus communication address	1502, 1503	CANopen communication address	0x2233, 0x00			

P2.52	Fully-closed loop vibration suppressor compensation gain	Setting range	Default	Unit	Applicable mode		
		0-1000	0	%	-	-	-
This parameter is used to set the compensation gain of fully-closed loop vibration suppressor.							
P2.52	Data size	16bit	Data format	DEC			
	Modbus communication address	1504, 1505	CANopen communication address	0x2234, 0x00			

P2.53	Medium frequency vibration control switch	Setting range	Default	Unit	Applicable mode		
		0-1	0	-	P	S	T
This parameter specifies whether the medium frequency vibration control is valid.							

		Set value	Function					
		[0]	Invalid					
		1	Valid					
P2.53	Data size	16bit	Data format	DEC				
	Modbus communication address	1506, 1507	CANopen communication address	0x2235, 0x00				
P2.54	Medium frequency vibration control frequency	Setting range	Default	Unit	Applicable mode			
		1-2000	100	Hz	P	S	T	
This parameter specifies the frequency for medium frequency vibration control.								
P2.54	Data size	16bit	Data format	DEC				
	Modbus communication address	1508, 1509	CANopen communication address	0x2236, 0x00				
P2.55	Inertia fine tuning of medium frequency vibration control	Setting range	Default	Unit	Applicable mode			
		1-1000	100	%	P	S	T	
This parameter specifies the inertia adjustment for medium frequency vibration control. The default value 100% indicates that no inertia adjustment is performed for medium frequency vibration control.								
P2.55	Data size	16bit	Data format	DEC				
	Modbus communication address	1510, 1511	CANopen communication address	0x2237, 0x00				
P2.56	Attenuation gain of medium frequency vibration control <input checked="" type="checkbox"/>	Setting range	Default	Unit	Applicable mode			
		0-1000	0	%	P	S	T	
This parameter specifies the attenuation gain for medium frequency vibration control. The default value 0 indicates that there is no attenuation effect on medium frequency vibration control. You can set this parameter based on the actual commissioning result. Ideally, if this parameter is set to 100%, the medium frequency vibration is controlled completely.								
P2.56	Data size	16bit	Data format	DEC				
	Modbus communication	1512, 1513	CANopen communication	0x2238, 0x00				

		address			address			
P2.57	Fine tuning of medium frequency vibration control filter time 1	Setting range	Default	Unit	Applicable mode			
		-10.00-10.00	0.00	ms	P	S	T	
This parameter is used to set the fine tuning of medium frequency vibration control filter time 1, which can be calculated automatically based on P2.54 [medium frequency vibration control frequency]. You can carry out fine tuning via this parameter.								
P2.57	Data size	16bit	Data format		DEC			
	Modbus communication address	1514, 1515	CANopen communication address		0x2239, 0x00			
P2.58	Fine tuning of medium frequency vibration control filter time 2	Setting range	Default	Unit	Applicable mode			
		-10.00-10.00	0.00	ms	P	S	T	
This parameter is used to set the fine tuning of medium frequency vibration control filter time 2, which can be calculated automatically based on P2.54 [medium frequency vibration control frequency]. You can carry out fine tuning via this parameter.								
P2.58	Data size	16bit	Data format		DEC			
	Modbus communication address	1516, 1517	CANopen communication address		0x223A, 0x00			
P2.60 ²	Speed observer	Setting range	Default	Unit	Applicable mode			
		0-2	0	-	P	S	T	
This parameter specifies whether the speed observer is valid.								
		Set value	Function					
		[0]	Invalid					
		1	Speed observation					
		2	Speed observation					
P2.60 ²	Data size	16bit	Data format		DEC			
	Modbus communication address	1520, 1521	CANopen communication address		0x223C, 0x00			

P2.61	Speed observer gain	Setting range	Default	Unit	Applicable mode		
		1-1000	100	Hz	P	S	T
This parameter is used to set the gain of the speed observer. Increasing the setting value may increase the response speed of the actual speed, but the vibration and noise may be raised too.							
P2.61	Data size	16bit	Data format	DEC			
	Modbus communication address	1522, 1523	CANopen communication address	0x223D, 0x00			
P2.70	Friction compensation cut-off speed	Setting range	Default	Unit	Applicable mode		
		0-1000	20	r/min	P	S	-
This parameter is used to set the cut-off speed of friction compensation.							
P2.70	Data size	16bit	Data format	DEC			
	Modbus communication address	1540, 1541	CANopen communication address	0x2246, 0x00			
P2.71	Positive torque coefficient of friction compensation	Setting range	Default	Unit	Applicable mode		
		0.0-100.0	0.0	%/(10r/min)	P	S	-
This parameter is used to set the friction compensation value added to torque command when a forward position command or speed command is received.							
P2.71	Data size	16bit	Data format	DEC			
	Modbus communication address	1542, 1543	CANopen communication address	0x2247, 0x00			
P2.72	Negative torque coefficient of friction compensation	Setting range	Default	Unit	Applicable mode		
		-100.0-0.0	0.0	%/(10r/min)	P	S	-
This parameter is used to set the friction compensation value added to torque command when a negative position command or speed command is received.							
P2.72	Data size	16bit	Data format	DEC			
	Modbus communication address	1544, 1545	CANopen communication address	0x2248, 0x00			

P2.73	Friction compensation	Setting range	Default	Unit	Applicable mode		
		0-1	0	-	P	S	-
This parameter specifies whether friction compensation is valid.							
		Set value	Function				
		[0]	Invalid				
		1	Friction compensation				
P2.73	Data size	16bit	Data format	DEC			
	Modbus communication address	1546, 1547	CANopen communication address	0x2249, 0x00			
P2.74	Automatic mode switch	Setting range	Default	Unit	Applicable mode		
		0-1	0	-	P	S	T
This parameter specifies whether the automatic mode is valid.							
		Set value	Function				
		[0]	Invalid				
		1	Valid				
P2.74	Data size	16bit	Data format	DEC			
	Modbus communication address	1548, 1549	CANopen communication address	0x224A, 0x00			
P2.75	Automatic mode gain	Setting range	Default	Unit	Applicable mode		
		0.0-3276.7	40.0	-	P	S	T
This parameter specifies the automatic mode gain.							
P2.75	Data size	16bit	Data format	DEC			
	Modbus communication address	1550, 1551	CANopen communication address	0x224B, 0x00			
P2.76	Automatic mode inertia fine-tuning	Setting range	Default	Unit	Applicable mode		
		0-1000	100	%	P	S	T
This parameter specifies the automatic mode inertia fine-tuning.							
P2.76	Data size	16bit	Data format	DEC			

	Modbus communication address	1552, 1553	CANopen communication address	0x224C, 0x00
--	------------------------------	------------	-------------------------------	--------------

P2.77	(Reserved)	Setting range	Default	Unit	Applicable mode		
		-	-	-	P	S	T

This parameter cannot be modified.

P2.77	Data size	16bit	Data format	DEC
	Modbus communication address	1554, 1555	CANopen communication address	0x224D, 0x00

P2.78	(Reserved)	Setting range	Default	Unit	Applicable mode		
		-	-	-	P	S	T

This parameter cannot be modified.

P2.78	Data size	16bit	Data format	DEC
	Modbus communication address	1556, 1557	CANopen communication address	0x224E, 0x00

P2.79	(Reserved)	Setting range	Default	Unit	Applicable mode		
		-	-	-	P	S	T

This parameter cannot be modified.

P2.79	Data size	16bit	Data format	DEC
	Modbus communication address	1558, 1559	CANopen communication address	0x224F, 0x00

P2.80	(Reserved)	Setting range	Default	Unit	Applicable mode		
		-	-	-	P	S	T

This parameter cannot be modified.

P2.80	Data size	16bit	Data format	DEC
	Modbus communication address	1560, 1561	CANopen communication address	0x2250, 0x00

P2.81	(Reserved)	Setting range	Default	Unit	Applicable mode		
		-	-	-	P	S	T
This parameter cannot be modified.							
P2.81	Data size	32bit	Data format	DEC			
	Modbus communication address	1562, 1563	CANopen communication address	0x2251, 0x00			
P2.82	(Reserved)	Setting range	Default	Unit	Applicable mode		
		-	-	-	P	S	T
This parameter cannot be modified.							
P2.82	Data size	32bit	Data format	DEC			
	Modbus communication address	1564, 1565	CANopen communication address	0x2252, 0x00			
P2.83	(Reserved)	Setting range	Default	Unit	Applicable mode		
		-	-	-	P	S	T
This parameter cannot be modified.							
P2.83	Data size	32bit	Data format	DEC			
	Modbus communication address	1566, 1567	CANopen communication address	0x2253, 0x00			
P2.84	(Reserved)	Setting range	Default	Unit	Applicable mode		
		-	-	-	P	S	T
This parameter cannot be modified.							
P2.84	Data size	32bit	Data format	DEC			
	Modbus communication address	1568, 1569	CANopen communication address	0x2254, 0x00			
P2.85	Torque feed-forward	Setting range	Default	Unit	Applicable mode		

	selection	0-1	0	-	P	S	T
This parameter specifies the torque feed-forward selection.							
	Set value	Function					
	[0]	Speed command feed-forward					
	1	Position command feed-forward					
P2.85	Data size	16bit	Data format		DEC		
	Modbus communication address	1570, 1571	CANopen communication address		0x2255, 0x00		
P2.86	Flux-weakening control switch	Setting range	Default	Unit	Applicable mode		
		0-3	0	-	P	S	T
This parameter specifies whether the flux-weakening control is effective and the mode of flux-weakening control.							
	Set value	Function					
	[0]	Invalid					
	1	Open-loop flux-weakening					
	2	Closed-loop flux-weakening					
	3	Closed-loop flux-weakening with feed-forward					
P2.86	Data size	16bit	Data format		DEC		
	Modbus communication address	1572, 1573	CANopen communication address		0x2256, 0x00		
P2.87	Voltage utilization in flux-weakening control	Setting range	Default	Unit	Applicable mode		
		1-99	90	%	P	S	T
This parameter specifies voltage utilization in flux-weakening control.							
P2.87	Data size	16bit	Data format		DEC		
	Modbus communication address	1574, 1575	CANopen communication address		0x2257, 0x00		

P2.88	Open-loop flux-weakening bandwidth	Setting range	Default	Unit	Applicable mode		
		1-500	50	%	P	S	T
This parameter specifies the open-loop flux-weakening bandwidth.							
P2.88	Data size	16bit	Data format	DEC			
	Modbus communication address	1576, 1577	CANopen communication address	0x2258, 0x00			
P2.89	Closed-loop flux-weakening bandwidth	Setting range	Default	Unit	Applicable mode		
		0.01-100	2.00	%	P	S	T
This parameter specifies the closed-loop flux-weakening bandwidth.							
P2.89	Data size	16bit	Data format	DEC			
	Modbus communication address	1578, 1579	CANopen communication address	0x2259, 0x00			
P2.90	Max. flux-weakening current in closed-loop flux-weakening control	Setting range	Default	Unit	Applicable mode		
		1-100	90	%	P	S	T
This parameter specifies the max. flux-weakening current in closed-loop flux-weakening control.							
P2.90	Data size	16bit	Data format	DEC			
	Modbus communication address	1580, 1581	CANopen communication address	0x225A, 0x00			
P2.91	Unbiased control gain	Setting range	Default	Unit	Applicable mode		
		1-2000	300	1/s	P	S	T
This parameter specifies the unbiased control gain.							
P2.91	Data size	16bit	Data format	DEC			
	Modbus communication	1582, 1583	CANopen communication	0x225B, 0x00			

	address		address				
P2.92	Unbiased control decay coefficient	Setting range	Default	Unit	Applicable mode		
		50–200	100	%	P	S	T
This parameter specifies the unbiased control decay coefficient.							
P2.92	Data size	16bit	Data format	DEC			
	Modbus communication address	1584, 1585	CANopen communication address	0x225C, 0x00			

9.4 I/O management parameters (Group P3 parameters)

9.4.1 Digital input/output configuration

P3.00 ¹	Input configuration of digital 1	Setting range	Default	Unit	Applicable mode		
		0x000–0x136	0x003	-	P	S	T
This parameter specifies the input of digital 1. It is in the hexadecimal format. In the expression of 0x*—, * indicates the valid mode, the value 0 indicates the input is valid when the optical coupler is conductive, while the value 1 indicates the input is valid when the optical coupler is not conductive. In the expression of 0x—**, ** indicate the function settings. The detailed function settings are listed in the following.							
		Set value		Applicable mode			
Signal name	Symbol	Valid when optical coupler not conducted	Valid when optical coupler conducted				
Invalid	—	0x100	0x000	P	S	T	
Positive direction drive disabling	POT	0x101	0x001	P	S	T	
Negative direction drive disabling	NOT	0x102	0x002	P	S	T	
Servo enabling	SON	0x103	0x003	P	S	T	
Alarm clearing	CLA	0x104	0x004	P	S	T	
Control mode switchover	MCH	0x105	0x005	P	S	T	
Gain switchover	PLC	0x106	0x006	P	S	T	
Clearing residual pulses	RPC	0x107	0x007	P	-	-	

Command pulse disabling	PLL	0x108	0x008	P	-	-
Torque limit switchover	TLC	0x109	0x009	P	S	-
Internal speed command 1	SPD1	0x10A	0x00A	-	S	T
Internal speed command 2	SPD2	0x10B	0x00B	-	S	T
Internal speed command 3	SPD3	0x10C	0x00C	-	S	-
Zero-speed clamp	ZRS	0x10D	0x00D	-	S	T
Speed command sign	S-SIGN	0x10E	0x00E	-	S	-
Torque command sign	T-SIGN	0x10F	0x00F	-	-	T
Internal position command 1	POS1	0x110	0x010	P	-	-
Internal position command 2	POS2	0x111	0x011	P	-	-
Internal position command 3	POS3	0x112	0x012	P	-	-
Internal position command 4	POS4	0x113	0x013	P	-	-
External fault	EXT	0x114	0x014	P	S	T
Inertia ratio switchover	JC	0x115	0x015	P	S	T
Emergency stop	EMG	0x116	0x016	P	S	T
HOME switch input	HOME	0x117	0x017	P	-	-
Triggering homing	HTRG	0x118	0x018	P	-	-
Numerator 1 of electric gear ratio	SC1	0x119	0x019	P	-	-
Numerator 2 of electric gear ratio	SC2	0x11A	0x01A	P	-	-
PTP control trigger	TRIG	0x11B	0x01B	P	-	-
Input switchover for vibration suppression	VS-SEL	0x11C	0x01C	P	-	-
Quick stop	Q-STOP	0x11D	0x01D	P	S	T
PTP control stop	PTP-ST	0x11E	0x01E	P	-	-
Absolute position clearing	PCLR	0x11F	0x01F	P	-	-
Internal position command 5	POS5	0x120	0x020	P	-	-

Internal position command 6	POS6	0x121	0x021	P	-	-
Internal position command 7	POS7	0x122	0x022	P	-	-
Forward jogging	FJOG	0x123	0x023	P	-	-
Reverse jogging	RJOG	0x124	0x024	P	-	-
High/low speed switching of jogging	JOGC	0x125	0x025	P	-	-
(Reserved)	/	0x126	0x026	-	-	-
(Reserved)	/	0x127	0x027	-	-	-
(Reserved)	/	0x128	0x028	-	-	-
(Reserved)	/	0x129	0x029	-	-	-
(Reserved)	/	0x12A	0x02A	-	-	-
(Reserved)	/	0x12B	0x02B	-	-	-
Terminal JOG enabling	DJOG	0x12C	0x02C	P	-	-
Gantry synchronization input clear	GIN	0x12D	0x02D	P	-	-
Master gantry synchronization alignment sensor	GSM	0x12E	0x02E	P	-	-
Slave gantry synchronization alignment sensor	GSS	0x12F	0x02F	P	-	-
Dynamic braking relay feedback	DBS	0x130	0x030	P	S	T
Manual and automatic switching of turret	DAT	0x131	0x031	P	-	-
Forward jogging of turret	DFJ	0x132	0x032	P	-	-
Reverse jogging of turret	DRJ	0x133	0x033	P	-	-
Switching between fully-closed loop and semi-closed loop	FCS	0x134	0x034	P	-	-
PTP terminal pause	PSTOP	0x135	0x035	P	-	-
EzJOG terminal pause	ESTOP	0x136	0x036	P	-	-
Magnetic pole detection enable	/	0x138	0x038	P	S	T
Note: The default values indicate the functions applied in position mode.						
P3.00 ¹	Data size	16bit	Data format	HEX		

	Modbus communication address	1600, 1601	CANopen communication address	0x2300, 0x00
--	------------------------------	------------	-------------------------------	--------------

P3.01 ¹	Input configuration of digital 2	Setting range	Default	Unit	Applicable mode		
		0x000–0x136	0x00D	-	P	S	T
P3.02 ¹	Input configuration of digital 3	Setting range	Default	Unit	Applicable mode		
		0x000–0x136	0x004	-	P	S	T
P3.03 ¹	Input configuration of digital 4	Setting range	Default	Unit	Applicable mode		
		0x000–0x136	0x016	-	P	S	T
P3.04 ¹	Input configuration of digital 5	Setting range	Default	Unit	Applicable mode		
		0x000–0x136	0x019	-	P	S	T
P3.05 ¹	Input configuration of digital 6	Setting range	Default	Unit	Applicable mode		
		0x000–0x136	0x01A	-	P	S	T
P3.06 ¹	Input configuration of digital 7	Setting range	Default	Unit	Applicable mode		
		0x000–0x136	0x001	-	P	S	T
P3.07 ¹	Input configuration of digital 8	Setting range	Default	Unit	Applicable mode		
		0x000–0x136	0x002	-	P	S	T
P3.08 ¹	Input configuration of digital 9	Setting range	Default	Unit	Applicable mode		
		0x000–0x136	0x007	-	P	S	T
P3.09 ¹	Input configuration of digital 10	Setting range	Default	Unit	Applicable mode		
		0x000–0x136	0x008	-	P	S	T

These parameters are used to set the input functions for digital 2 to 10. These parameters are in the hexadecimal format. The setting method is the same as P3.00.

Note: The default values indicate the functions applied in position mode.

P3.01 ¹	Data size	16bit	Data format	HEX
	Modbus communication address	1602, 1603	CANopen communication address	0x2301, 0x00
P3.02 ¹	Data size	16bit	Data format	HEX

	Modbus communication address	1604, 1605	CANopen communication address	0x2302, 0x00
P3.03 ¹	Data size	16bit	Data format	HEX
	Modbus communication address	1606, 1607	CANopen communication address	0x2303, 0x00
P3.04 ¹	Data size	16bit	Data format	HEX
	Modbus communication address	1608, 1609	CANopen communication address	0x2304, 0x00
P3.05 ¹	Data size	16bit	Data format	HEX
	Modbus communication address	1610, 1611	CANopen communication address	0x2305, 0x00
P3.06 ¹	Data size	16bit	Data format	HEX
	Modbus communication address	1612, 1613	CANopen communication address	0x2306, 0x00
P3.07 ¹	Data size	16bit	Data format	HEX
	Modbus communication address	1614, 1615	CANopen communication address	0x2307, 0x00
P3.08 ¹	Data size	16bit	Data format	HEX
	Modbus communication address	1616, 1617	CANopen communication address	0x2308, 0x00
P3.09 ¹	Data size	16bit	Data format	HEX
	Modbus communication address	1618, 1619	CANopen communication address	0x2309, 0x00

P3.10 ¹	Output configuration of digital 1	Setting range	Default	Unit	Applicable mode		
		0x000–0x11F	0x001	-	P	S	T

This parameter specifies the output of digital 1. It is in the hexadecimal format.
 In the expression of 0x*—, * indicates the valid mode, the value 0 indicates the input is valid when the optical coupler is conductive, while the value 1 indicates the input is valid when the optical coupler is not conductive.
 In the expression of 0x—**, ** indicate the function settings. The detailed function settings

are listed in the following.

Signal name	Symbol	Set value		Applicable mode		
		Valid when optical coupler not conducted	Valid when optical coupler conducted			
Invalid	—	0x100	0x000	P	S	T
Servo ready for output	RDY	0x101	0x001	P	S	T
Servo run output	RUN	0x102	0x002	P	S	T
Fault output	ALM	0x103	0x003	P	S	T
(Reserved)	/	0x104	0x004	-	-	-
Electromagnetic brake release signal	BRK	0x105	0x005	P	S	T
Position command validity	PCMD	0x106	0x006	P	-	-
Positioning completed	PLR	0x107	0x007	P	-	-
Control mode switchover status	MCHS	0x108	0x008	P	S	T
Speed consistent	COIN	0x109	0x009	P	S	T
Speed reached	SR	0x10A	0x00A	P	S	T
Speed being limited	SL	0x10B	0x00B	-	-	T
Speed command validity	SCMD	0x10C	0x00C	-	S	-
Zero output of speed	ZSO	0x10D	0x00D	P	S	T
Torque being limited	LM	0x10E	0x00E	P	S	T
Zeroing completed	HEND	0x10F	0x00F	P	-	-
Torque reaching	TRCH	0x110	0x010	-	-	T
(Reserved)	/	0x111	0x011	-	-	-
(Reserved)	/	0x112	0x012	-	-	-
(Reserved)	/	0x113	0x013	-	-	-
(Reserved)	/	0x114	0x014	-	-	-
(Reserved)	/	0x115	0x015	-	-	-
PTP arrival	PTPF	0x116	0x016	P	-	-
PTP output 1	PTPO1	0x117	0x017	P	-	-
PTP output 2	PTPO2	0x118	0x018	P	-	-
PTP output 3	PTPO3	0x119	0x019	P	-	-
PTP output 4	PTPO4	0x11A	0x01A	P	-	-
PTP output 5	PTPO5	0x11B	0x01B	P	-	-

PTP output 6	PTPO6	0x11C	0x01C	P	-	-
PTP output 7	PTPO7	0x11D	0x01D	P	-	-
Gantry synchronization output clear	GSC	0x11E	0x01E	P	-	-
Dynamic braking relay control	DBRC	0x11F	0x01F	P	S	T

Note: The default values indicate the functions applied in position mode.

P3.10 ¹	Data size	16bit	Data format	HEX
	Modbus communication address	1620, 1621	CANopen communication address	0x230A, 0x00

P3.11 ¹	Output configuration of digital 2	Setting range	Default	Unit	Applicable mode		
		0x000–0x11F	0x003	-	P	S	T
P3.12 ¹	Output configuration of digital 3	Setting range	Default	Unit	Applicable mode		
		0x000–0x11F	0x007	-	P	S	T
P3.13 ¹	Output configuration of digital 4	Setting range	Default	Unit	Applicable mode		
		0x000–0x11F	0x00D	-	P	S	T

These parameters are used to set the output functions for digital 2 to 6. These parameters are in the hexadecimal format. The setting method is the same as P3.10.

Note: The default values indicate the functions applied in position mode.

P3.11 ¹	Data size	16bit	Data format	HEX
	Modbus communication address	1622, 1623	CANopen communication address	0x230B, 0x00
P3.12 ¹	Data size	16bit	Data format	HEX
	Modbus communication address	1624, 1625	CANopen communication address	0x230C, 0x00
P3.13 ¹	Data size	16bit	Data format	HEX
	Modbus communication address	1626, 1627	CANopen communication address	0x230D, 0x00

P3.16	Channel 1 DI-captured encoder function configuration	Setting range	Default	Unit	Applicable mode		
		0-30A	0	-	P	S	T
<p>DI capture setting, 1-10 corresponds to capture ports DI1-DI10. When it is set to capture through the falling edge, the corresponding value of the capture port is increased by 256. When it is set to capture through the rising edge, the corresponding value of the capture port is increased by 512. When it is set to capture through both the rising edge and falling edge, the corresponding value of the capture port is increased by 768.</p>							
P3.16	Data size	16bit	Data format		HEX		
	Modbus communication address	1632, 1633	CANopen communication address		0x2310, 0x00		

P3.17	Channel 2 DI-captured encoder function configuration	Setting range	Default	Unit	Applicable mode		
		0-30A	0	-	P	S	T
<p>DI capture setting, 1-10 corresponds to capture ports DI1-DI10. When it is set to capture through the falling edge, the corresponding value of the capture port is increased by 256. When it is set to capture through the rising edge, the corresponding value of the capture port is increased by 512. When it is set to capture through both the rising edge and falling edge, the corresponding value of the capture port is increased by 768.</p>							
P3.17	Data size	16bit	Data format		HEX		
	Modbus communication address	1634, 1635	CANopen communication address		0x2311, 0x00		

9.4.2 Analog input/output adjustment

P3.20	Offset of analog input 1	Setting range	Default	Unit	Applicable mode		
		-10.000-10.000	0.000	V	P	S	T
<p>This parameter is used to adjust analog input 1 to improve the effective accuracy of the analog input. Due to reasons such as the zero drift of analog input devices or induced voltage in the ambient environment, the actual analog input value may deviate from the expected value, and such deviation can be eliminated by setting the offset of AI.</p>							

See the following figure for the analog input offset voltage:

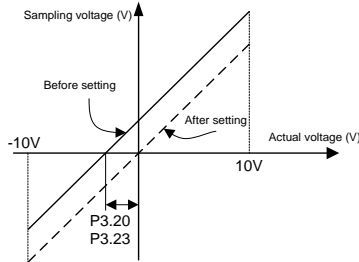

Example: After analog input 1 command terminal of the drive is connected to the analog reference signal, even if the analog reference signal is 0, the voltage value of analog input 1 (R1.05) displayed by the panel will be 0.02V, P3.20 must be set to 0.02 at this time. The drive automatically subtracts 0.02V from the analog input value received. If the analog input 2 voltage displayed by the panel is -0.02V, P3.20 must be set to -0.02. The drive automatically adds 0.02V to the analog input value received, and the value displayed by the panel changes at the same time.

P3.20	Data size	32bit	Data format	DEC
	Modbus communication address	1640, 1641	CANopen communication address	0x2314, 0x00

P3.21	Filter of analog input 1	Setting range	Default	Unit	Applicable mode		
		0.0~1000.0	1.0	ms	P	S	T

This parameter is used to set the time constant of the first-order low-pass filter corresponding to analog input 1. Setting this parameter can smooth the command change when the analog input changes sharply. See the figure below.

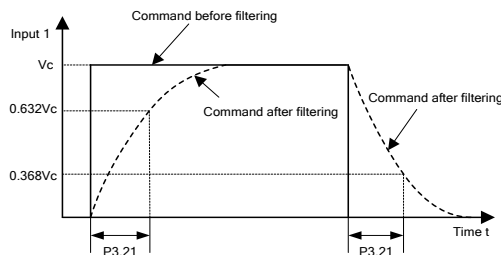

P3.21	Data size	16bit	Data format	DEC
	Modbus communication address	1642, 1643	CANopen communication address	0x2315, 0x00

P3.22	OV protection threshold of analog input 1	Setting range	Default	Unit	Applicable mode		
		0.000–10.000	0.000	V	P	S	T

This parameter is used to set the overvoltage protection threshold of analog input 1. If the absolute value of R1.05 exceeds the set value of this parameter, the system reports a fault.

Note:

- The default value 0 indicates OV protection is not used.
- The setting of this parameter cannot be greater than 10V. Otherwise, the drive may be damaged.

P3.22	Data size	32bit	Data format	DEC
	Modbus communication address	1644, 1645	CANopen communication address	0x2316, 0x00

P3.23	Offset of analog input 2	Setting range	Default	Unit	Applicable mode		
		-10.000–10.000	0.000	V	P	S	T

This parameter is used to adjust analog input 2 to improve the effective accuracy of the analog input. The setting method is the same as P3.20.

P3.23	Data size	32bit	Data format	DEC
	Modbus communication address	1646, 1647	CANopen communication address	0x2317, 0x00

P3.24	Filter of analog input 2	Setting range	Default	Unit	Applicable mode		
		0.0–1000.0	1.0	ms	P	S	T

This parameter is used to set the time constant of the first-order low-pass filter corresponding to the command. Setting this parameter can smooth the changing of actual output command when the command changes sharply. See the figure below.

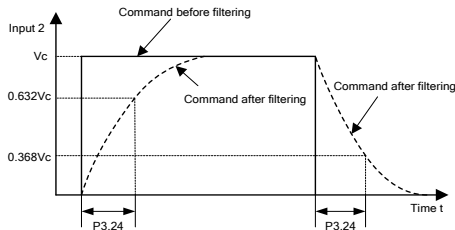

P3.24	Data size	16bit	Data format	DEC
	Modbus communication address	1648, 1649	CANopen communication address	0x2318, 0x00

P3.25	OV protection threshold of analog input 2	Setting range	Default	Unit	Applicable mode		
		0.000-10.000	0.000	V	P	S	T

This parameter is used to set the overvoltage protection threshold of analog input 2.

Note:

- The default value 0 indicates OV protection is not used.
- The setting of this parameter cannot be greater than 10V. Otherwise, the drive may be damaged.

P3.25	Data size	32bit	Data format	DEC
	Modbus communication address	1650, 1651	CANopen communication address	0x2319, 0x00

P3.26 ¹	Function of analog input 1	Setting range	Default	Unit	Applicable mode		
		0-7	0	-	P	S	T

P3.27 ¹	Function of analog input 2	Setting range	Default	Unit	Applicable mode		
		0-7	3	-	P	S	T

Select the analog input channel function via these parameters.

Set value	Definition	Unit
[0]	Invalid	-
1	Speed limit	r/min
2	Forward torque limit	0.1%
3	Velocity	r/min
4	Torque command	0.1%
5	Speed observation	r/min
6	Torque compensation	0.1%
7	Negative torque limit	0.1%

P3.26 ¹	Data size	16bit	Data format	DEC
	Modbus communication address	1652, 1653	CANopen communication address	0x231A, 0x00

P3.27 ¹	Data size	16bit	Data format	DEC
	Modbus communication address	1654, 1655	CANopen communication address	0x231B, 0x00

P3.28	Analog speed compensation gain	Setting range	Default	Unit	Applicable mode		
		0.0–100.0	0.0	%	P		

Set the analog speed compensation gain via this parameter.

P3.28	Data size	16bit	Data format	DEC
	Modbus communication address	1656, 1657	CANopen communication address	0x231C, 0x00

P3.29	Analog torque compensation gain	Setting range	Default	Unit	Applicable mode		
		0.0–100.0	0.0	%	P	S	T

Set the analog torque compensation gain via this parameter.

P3.29	Data size	16bit	Data format	DEC
	Modbus communication address	1658, 1659	CANopen communication address	0x231D, 0x00

P3.30 ¹	Function of analog output 1	Setting range	Default	Unit	Applicable mode		
		0–19	0	-	P	S	T

P3.32 ¹	Function of analog output 2	Setting range	Default	Unit	Applicable mode		
		0–19	0	-	P	S	T

These parameters are used to select the monitoring parameters to be outputted in analog form.

Set value	Definition	Unit
[0]	Invalid	-
1	Motor speed	r/min
2	Speed of position command	r/min
3	Internal position command	pulse (encoder unit)
4	Velocity	r/min
5	Torque command	0.1%
6	Torque feedback	0.1%
7	Command position	reference unit

		deviation	
8	Encoder position deviation		pulse (encoder unit)
9	Fully-closed loop position deviation		pulse (linear encoder unit)
10	Hybrid control deviation		reference unit
11	Main circuit DC voltage		V
12	Forward torque limit		0.1%
13	Negative torque limit		0.1%
14	Speed limit		r/min
15	Inertia ratio		%
16	Analog input 1*		V
17	Analog input 2*		V
18	Analog input 3*		V
19	Drive temperature		°C

Note: * If P3.31 and P3.33 are set to 1000, analog input 1, analog input 2 and analog input 3 can output the voltage value inputted from the analog input terminals at any time.

P3.30 ¹	Data size	16bit	Data format	DEC
	Modbus communication address	1660, 1661	CANopen communication address	0x231E, 0x00
P3.32 ¹	Data size	16bit	Data format	DEC
	Modbus communication address	1664, 1665	CANopen communication address	0x2320, 0x00

P3.31	Voltage gain of analog output 1	Setting range	Default	Unit	Applicable mode		
		1-214748364	1	[P3.30 unit]/V	P	S	T
P3.33	Voltage gain of analog output 2	Setting range	Default	Unit	Applicable mode		
		1-214748364	1	[P3.32 unit]/V	P	S	T

These parameters are used to set the gain of analog output. The detailed unit is relative to P3.30 and P3.32.

Example: Suppose the actual speed is outputted from the AO1 terminal, 10V corresponds to a speed of 3000r/min and 0V corresponds to 0. Then set P3.30=1, P3.31=300, the relation between the actual speed reference and output voltage is shown as below:

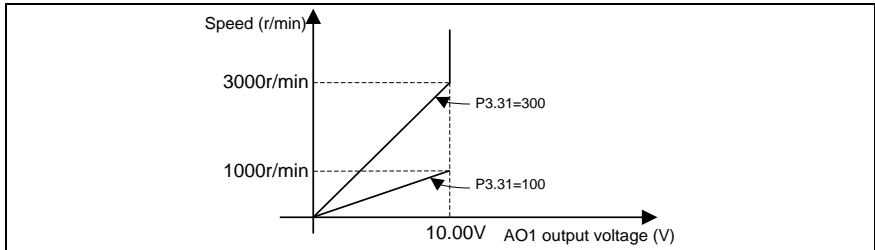

Note:

- In the example, when the actual output speed is equal to or greater than 3000r/min, AO1 output is 10V. Select proper gain according to the actual situation.
- If other functions are set for P3.30 and P3.32, the gain setting method is similar.

P3.31	Data size	32bit	Data format	DEC
	Modbus communication address	1662, 1663	CANopen communication address	0x231F, 0x00
P3.33	Data size	32bit	Data format	DEC
	Modbus communication address	1666, 1667	CANopen communication address	0x2321, 0x00

P3.34	Offset voltage of analog output 1	Setting range	Default	Unit	Applicable mode		
		-10.000-10.000	0.000	V	P	S	T
P3.35	Offset voltage of analog output 2	Setting range	Default	Unit	Applicable mode		
		-10.000-10.000	0.000	V	P	S	T

These parameters can be used to adjust the AO1 and AO2 to regulate the actual value of analog output voltage. Actual value of analog output voltage = Original value of analog output voltage + Offset value of analog output voltage

P3.34	Data size	32bit	Data format	DEC
	Modbus communication address	1668, 1669	CANopen communication address	0x2322, 0x00
P3.35	Data size	32bit	Data format	DEC
	Modbus communication address	1670, 1671	CANopen communication address	0x2323, 0x00

P3.36 ¹	Analog output monitoring setting	Setting range	Default	Unit	Applicable mode		
		0-2	0	-	P	S	T

This parameter is used to set the output mode and voltage range of the analog output.

Set value	Output mode
[0]	Voltage output with sign (-10V-10V)
1	Absolute voltage output (0V-10V)
2	Voltage output with zero offset (0V-10V, 5V center)

P3.36 ¹	Data size	16bit	Data format	DEC
	Modbus communication address	1672, 1673	CANopen communication address	0x2324, 0x00

P3.37*	Communication-based control analog output 1	Setting range	Default	Unit	Applicable mode		
		-2147483648-2147483648	0	-	P	S	T

Communication-based control analog output 1 is valid when P3.30 is 0.

P3.37*	Data size	32bit	Data format	DEC
	Modbus communication address	1674, 1675	CANopen communication address	0x2325, 0x00

P3.38*	Communication-based control analog output 2	Setting range	Default	Unit	Applicable mode		
		-2147483648-2147483648	0	-	P	S	T

Communication-based control analog output 2 is valid when P3.32 is 0.

P3.38*	Data size	32bit	Data format	DEC
	Modbus communication address	1676, 1677	CANopen communication address	0x2326, 0x00

P3.39	Communication-based control I/O output	Setting range	Default	Unit	Applicable mode		
		0-0FFF	0	-	P	S	T

Communication control I/O output, enabled by the bit 12 of P4.43. ABC indicates three hex numbers, corresponding to digital outputs 1-4 respectively.

1. Ah: Digital output state after communication disconnection (24-D alarm). [0]: Invalid, by default, and digital output state is unchanged; [1]: Enable, digital output state becomes 0.

2. Bh: Digital output enable. [0]: Invalid, by default; [1]: Enable, corresponding to digital output enable.

3. Ch: Digital output control. [0]: Corresponding to digital output 0 (logic state); [1]: Corresponding to digital output 1 (logic state).

P3.39	Data size	16bit	Data format	HEX
	Modbus communication address	1678, 1679	CANopen communication address	0x2327, 0x00

9.4.3 Digital input/output settings

P3.40 ¹	Disable travel limit switch	Setting range	Default	Unit	Applicable mode		
		0-2	1	-	P	S	T

This parameter specifies whether the forward drive disabling (0x001 or 0x101) digital input and reverse drive disabling (0x002 or 0x102) digital inputs in P3.00–P3.09 are valid. You can disable the travel limit switch function by setting this parameter.

Set value	Function
0	The travel limit switch is normal
[1]	The travel limit switch is disabled
2	A limit exceeding fault occurs.

Note: When the travel limit switch is normal and the digital input configured as forward drive disabling is active, the motor will stop immediately and cannot continue to run forward, but it is able to receive the reverse running command.

P3.40 ¹	Data size	16bit	Data format	DEC
	Modbus communication address	1680, 1681	CANopen communication address	0x2328, 0x00

P3.41 ¹	Disable emergency stop switch	Setting range	Default	Unit	Applicable mode		
		0-1	1	-	P	S	T

This parameter specifies whether the emergency stop (0x016 or 0x116) digital inputs in P3.00–P3.09 are valid. You can disable the emergency stop function by setting this parameter.

	Set value	Function
	0	The emergency stop switch is normal.
	[1]	The emergency stop switch is disabled.

If the digital input of emergency stop is valid, the alarm Er10-4 is reported.

Note:

- If the alarm Er10-4 is reported, the servo motor stops in the mode specified by P4.30.
- To clear the alarm Er10-4, ensure there is no danger for operating, clear the alarm signal (that is, disable the digital input of emergency stop), clear the alarm display, and then restart the servo drive.

P3.41 ¹	Data size	16bit	Data format	DEC
	Modbus communication address	1682, 1683	CANopen communication address	0x2329, 0x00

P3.43 ¹	Digital input filter	Setting range	Default	Unit	Applicable mode		
		1–800	1	0.125ms	P	S	T

This parameter specifies the filter time of the digital input.

Note: This parameter independently functions for 10 digital inputs.

P3.43 ¹	Data size	16bit	Data format	DEC
	Modbus communication address	1686, 1687	CANopen communication address	0x232B, 0x00

P3.44	Command pulse input invalid setting disabling	Setting range	Default	Unit	Applicable mode		
		0–1	0	-	P	-	-

This parameter specifies whether the command pulse disabling (0x008 or 0x108) digital inputs in P3.00–P3.09 are valid. You can disable the command pulse disabling function by setting this parameter.

0: The command pulse disabling input function is valid.

0: The command pulse disabling input function is invalid.

P3.44	Data size	16bit	Data format	DEC
	Modbus communication address	1688, 1689	CANopen communication	0x232C, 0x00

			address		
P3.45 ¹	Residual pulse clearing mode	Setting range	Default	Unit	Applicable mode
		0-1	1	-	P - -
This parameter specifies the valid mode for the residual pulse clearing (0x007 or 0x107) digital inputs in P3.00-P3.09.					
		Set value	Function		
		0	ON level clearing		
		[1]	Rising edge clearing		
P3.45 ¹	Data size	16bit	Data format	DEC	
	Modbus communication address	1690, 1691	CANopen communication address	0x232D, 0x00	
P3.46	Internal speed limit accuracy setting	Setting range	Default	Unit	Applicable mode
		0-1	0	-	P - -
This parameter specifies P4.31, P4.40 and P4.41 speed limit accuracy.					
P3.46	Data size	16bit	Data format	DEC	
	Modbus communication address	1692, 1693	CANopen communication address	0x232E, 0x00	
P3.50	Range of position arrival	Setting range	Default	Unit	Applicable mode
		0-2 ¹⁸	100	reference unit	P - -
This parameter specifies the position arrival range. If the deviation between the position feedback pulse and position command pulse is in this range, it indicates position arrival.					
P3.50	Data size	32bit	Data format	DEC	
	Modbus communication address	1700, 1701	CANopen communication address	0x2332, 0x00	
P3.51	Output mode of position arrival	Setting range	Default	Unit	Applicable mode
		0-4	0	-	P - -

This parameter specifies the condition for the position arrival output signal and the action mode after output.

Set value	Output mode
[0]	The output is valid when the position deviation is in the range of P3.50.
1	The output is valid when there is no position command and the position deviation is in the range of P3.50.
2	The output is valid when there is no position command, the zero-speed detection signal is valid, and the position deviation is in the range of P3.50.
3	The output is valid when there is a transition from with a position command to without a position command and the position deviation is in the range of P3.50. Subsequently, the system continuously outputs the valid state within the time specified by P3.52. Then, the system updates the output status of position arrival based on the position command and position deviation.
4	The output is valid when there is a transition from with a position command to without a position command and the position deviation is in the range of P3.50. Subsequently, the system continuously outputs the valid state within the time specified by P3.52.

P3.51	Data size	16bit	Data format	DEC
	Modbus communication address	1702, 1703	CANopen communication address	0x2333, 0x00

P3.52	Hold time of position arrival output terminal	Setting range	Default	Unit	Applicable mode		
		0-30000	0	ms	P	-	-

This parameter specifies the hold time of the position arrival output terminal.

Set value	Action
[0]	The hold time is infinite, and the holding is valid until the position in a next position command is arrived at.
1-30000	The holding is valid within the setting range. It becomes invalid once a next position command is received.

P3.52	Data size	16bit	Data format	DEC
	Modbus communication address	1704, 1705	CANopen communication address	0x2334, 0x00

P3.53	Speed consistency threshold	Setting range	Default	Unit	Applicable mode		
		10-20000	50	r/min	P	S	T
<p>This parameter specifies the condition for detecting speed consistency.</p> <p>If the difference between the speed command and motor speed is less than the setting of this parameter, then the speed consistency output status is valid.</p> <p>If the detection finds there is a lag of 10 r/min, the actual speed consistency range is as follows:</p> <p>If the speed consistency output is invalid, the validity threshold is (P3.53 - 10) r/min.</p> <p>If the speed consistency output is valid, the invalidity threshold is (P3.53 + 10) r/min.</p>							
P3.53	Data size	16bit	Data format	DEC			
	Modbus communication address	1706, 1707	CANopen communication address	0x2335, 0x00			
P3.54	Speed reaching range	Setting range	Default	Unit	Applicable mode		
		10-20000	1000	r/min	P	S	T
<p>This parameter specifies the condition for detecting speed reaching output. If the transient motor speed [R0.21] exceeds the setting of this parameter, the output is valid. The detection finds a lag of 10 r/min.</p>							
P3.54	Data size	16bit	Data format	DEC			
	Modbus communication address	1708, 1709	CANopen communication address	0x2336, 0x00			
P3.55	Zero speed range	Setting range	Default	Unit	Applicable mode		
		10-20000	50	r/min	P	S	T
<p>This parameter specifies the condition for detecting zero speed output. When the absolute value of the motor speed is within this range, the speed is considered as zero speed and the zero speed output signal is valid. The detection finds a lag of 10 r/min.</p>							
P3.55	Data size	16bit	Data format	DEC			
	Modbus communication address	1710, 1711	CANopen communication address	0x2337, 0x00			

P3.56	Servo lock time after braking	Setting range	Default	Unit	Applicable mode		
		0-1000	50	ms	P	S	T
<p>This parameter specifies the locked time of the servo after braking in locked state. If the servo is off in locked state, the digital output of the electromagnetic brake release signal (0x005 or 0x105) is invalid. Then the servo keeps being locked for a period of time so that the motor does not rotate during the action of the relay.</p>							
P3.56	Data size	16bit	Data format	DEC			
	Modbus communication address	1712, 1713	CANopen communication address	0x2338, 0x00			
P3.57	Electromagnetic brake closing delay	Setting range	Default	Unit	Applicable mode		
		0-30000	500	ms	P	S	T
<p>This parameter specifies the delay time of closing the electromagnetic brake. If the servo is off or an alarm is reported in running state and the speed may be too fast, the digital output of the electromagnetic brake release signal (0x005 or 0x105) becomes invalid after a period of delay. If the motor speed drops below the setting of P3.58 during the delay period, the digital output becomes invalid in advance.</p>							
P3.57	Data size	16bit	Data format	DEC			
	Modbus communication address	1714, 1715	CANopen communication address	0x2339, 0x00			
P3.58 ¹	Motor speed threshold at brake release	Setting range	Default	Unit	Applicable mode		
		0-6000	30	r/min	P	S	T
<p>This parameter specifies the motor speed threshold when the brake is released.</p>							
P3.58 ¹	Data size	16bit	Data format	DEC			
	Modbus communication address	1716, 1717	CANopen communication address	0x233A, 0x00			
P3.59	Torque reaching range	Setting range	Default	Unit	Applicable mode		
		5.0-300.0	50.0	%	-	-	T
<p>This parameter specifies the condition for detecting torque reaching output. If the motor</p>							

torque feedback exceeds the setting of this parameter, the output of torque reaching (0x010 or 0x110) is valid. There is 5% lag in detection.

P3.59	Data size	16bit	Data format	DEC
	Modbus communication address	1718, 1719	CANopen communication address	0x233B, 0x00

9.4.4 Analog input 3 adjustment

P3.70 ¹	Function of analog input 3	Setting range	Default	Unit	Applicable mode		
		0-7	4	-	P	S	T

This parameter specifies the function of analog input 3.

Set value	Definition	Unit
0	Invalid	-
1	Speed limit	r/min
2	Forward torque limit* ¹	0.1%
3	Speed command* ²	r/min
[4]	Torque command	0.1%
5	Speed observation	r/min
6	Torque compensation	0.1%
7	Negative torque limit	0.1%

Note:

- *¹ When P3.70 is set to 2 and P0.09 is set to 0 or 4, analog input 3 corresponds internally to a positive torque limiting function; P0.62–P0.65 and P3.23–P3.25 correspond internally to a negative torque limiting function.
- *² When P3.70 is set to 3, P0.42–P0.45 and P3.20–P3.22 become invalid.

P3.70 ¹	Data size	16bit	Data format	DEC
	Modbus communication address	1740, 1741	CANopen communication address	0x2346, 0x00

P3.71	Zero offset of analog input 3	Setting range	Default	Unit	Applicable mode		
		-10.000–10.000	0.000	V	P	S	T

This parameter specifies the zero offset of analog input 3.

P3.71	Data size	32bit	Data format	DEC
	Modbus communication address	1742, 1743	CANopen communication	0x2347, 0x00

			address	
--	--	--	---------	--

P3.72	Deadzone of analog input 3	Setting range	Default	Unit	Applicable mode		
		0.000–3.000	0.000	V	P	S	T

This parameter specifies the deadzone range of analog input 3.

P3.72	Data size	16bit	Data format	DEC		
	Modbus communication address	1744, 1745	CANopen communication address	0x2348, 0x00		

P3.73	Gain of analog input 3	Setting range	Default	Unit	Applicable mode		
		0–2000	300	[P3.70 unit]/V	P	S	T

This parameter specifies the gain of analog input 3, the gain unit is associated with P3.70.

P3.73	Data size	32bit	Data format	DEC		
	Modbus communication address	1746, 1747	CANopen communication address	0x2349, 0x00		

P3.74	Reverse of analog input 3	Setting range	Default	Unit	Applicable mode		
		0–1	0	-	P	S	T

This parameter specifies the voltage polarity of analog input 3.

Set value	Actual detection result	
[0]	Positive polarity	[+Voltage]→[Positive value], [-Voltage]→[Negative value]
1	Negative polarity	[+Voltage]→[Negative value], [-Voltage]→[Positive value]

P3.74	Data size	16bit	Data format	DEC		
	Modbus communication address	1748, 1749	CANopen communication address	0x234A, 0x00		

P3.75	OV protection threshold of analog input 3	Setting range	Default	Unit	Applicable mode		
		0.000–10.000	0.000	V	P	S	T

This parameter is used to set the overvoltage protection threshold of analog input 3.

If the absolute value of R1.07 exceeds the set value of this parameter, the system reports a fault.

P3.75	Data size	32bit	Data format	DEC
	Modbus communication address	1750, 1751	CANopen communication address	0x234B, 0x00

P3.76	Filter of analog input 3	Setting range	Default	Unit	Applicable mode		
		0.0-1000.0	0.0	ms	P	S	T

This parameter is used to set the time constant of the first-order low-pass filter corresponding to analog input 3.

P3.76	Data size	16bit	Data format	DEC
	Modbus communication address	1752, 1753	CANopen communication address	0x234C, 0x00

P3.77	Analog input deadzone mode	Setting range	Default	Unit	Applicable mode		
		0-1	0	-	P	S	T

This parameter specifies the voltage mode of the analog input deadzone.

Set value	Meaning
[0]	Normal mode
1	CNC mode: If the analog input is equal to or less than the deadzone, the valid value is 0. If the analog input is greater than the deadzone, the valid value is (Analog input - Deadzone).

P3.77	Data size	16bit	Data format	DEC
	Modbus communication address	1754, 1755	CANopen communication address	0x234D, 0x00

P3.89	Probe DI-captured filter time	Setting range	Default	Unit	Applicable mode		
		1-250	50	20ns	P	S	T

This parameter specifies the proper probe DI-captured filter time to increase the anti-interference capability of the pulse input.

P3.89	Data size	16bit	Data format	DEC
-------	-----------	-------	-------------	-----

	Modbus communication address	1778, 1779	CANopen communication address	0x2359, 0x00
--	------------------------------	------------	-------------------------------	--------------

P3.90	Pulse input filter time	Setting range	Default	Unit	Applicable mode		
		1-250	20	20ns	P	S	T

This parameter specifies the filter time for detecting pulse input to increase the anti-interference capability of the input pulse.

P3.90	Data size	16bit	Data format	DEC
	Modbus communication address	1780, 1781	CANopen communication address	0x235A, 0x00

P3.91	First encoder filter time	Setting range	Default	Unit	Applicable mode		
		1-250	20	20ns	P	S	T

This parameter specifies the proper first encoder filter time to increase the anti-interference capability of the first encoder.

P3.91	Data size	16bit	Data format	DEC
	Modbus communication address	1782, 1783	CANopen communication address	0x235B, 0x00

P3.92	Second encoder filter time	Setting range	Default	Unit	Applicable mode		
		1-250	20	20ns	P	S	T

This parameter specifies the proper second encoder filter time to increase the anti-interference capability of the second encoder.

P3.92	Data size	16bit	Data format	DEC
	Modbus communication address	1784, 1785	CANopen communication address	0x235C, 0x00

9.5 Extension and application (Group P4 parameters)

9.5.1 Communication settings

P4.00 ¹	EtherCAT node address	Setting range	Default	Unit	Applicable mode		
		-1-32767	-1	-	P	S	T

This parameter specifies the EtherCAT communication address.

P4.00 ¹	Data size	16bit	Data format	DEC
	Modbus communication address	1800, 1801	CANopen communication address	0x2400, 0x00

P4.01 ¹	485 local communication address	Setting range	Default	Unit	Applicable mode		
		1-255	1	-	P	S	T

This parameter specifies the local (or slave) communication address of 485 serial communication.

P4.01 ¹	Data size	16bit	Data format	DEC
	Modbus communication address	1802, 1803	CANopen communication address	0x2401, 0x00

P4.02 ¹	CAN communication baud rate	Setting range	Default	Unit	Applicable mode		
		0-5	1	-	P	S	T

This parameter is used to select CAN communication baud rate. Available baud rates are as follow:

Set value	Baud rate
0	1000kbps
[1]	500kbps
2	250kbps
3	125kbps
4	50kbps
5	20kbps

P4.02 ¹	Data size	16bit	Data format	DEC
	Modbus communication address	1804, 1805	CANopen communication address	0x2402, 0x00

P4.03 ¹	485 communication baud rate	Setting range	Default	Unit	Applicable mode		
		0-3	1	-	P	S	T

This parameter is used to select RS485 communication baud rate. Available baud rates are as follow:

	Set value	Baud rate	
	0	9600bps	
	[1]	19200bps	
	2	38400bps	
	3	57600bps	

P4.03 ¹	Data size	16bit	Data format	DEC
	Modbus communication address	1806, 1807	CANopen communication address	0x2403, 0x00

P4.04 ¹	485 communication parity mode	Setting range	Default	Unit	Applicable mode		
		0-5	0	-	P	S	T

This parameter is used to set the 485 communication parity mode and it only supports RTU mode.

Set value	Baud rate
[0]	No check (N, 8, 1)
1	Even check (E, 8, 1)
2	Odd check (O, 8, 1)
3	No check (N, 8, 2)
4	Even check (E, 8, 2)
5	Odd check (O, 8, 2)

P4.04 ¹	Data size	16bit	Data format	DEC
	Modbus communication address	1808, 1809	CANopen communication address	0x2404, 0x00

P4.05 ¹	CAN communication node	Setting range	Default	Unit	Applicable mode		
		1-127	1	-	P	S	T

This parameter is used to set the local (or salve) node number in CAN communication.

P4.05 ¹	Data size	16bit	Data format	DEC
	Modbus communication address	1810, 1811	CANopen communication address	0x2405, 0x00

P4.06	485 communication fault clearing mode	Setting range	Default	Unit	Applicable mode		
		0-1	1	-	P	S	T
This parameter specifies the mode for handling a fault that occurs in RS485 communication.							
		Set value	Meaning				
		0	The fault is not cleared.				
		[1]	The fault is cleared automatically.				
P4.06	Data size	16bit	Data format	DEC			
	Modbus communication address	1812, 1813	CANopen communication address	0x2406, 0x00			
P4.07 ¹	EtherCAT synchronous cycle	Setting range	Default	Unit	Applicable mode		
		0-30	1	ms	P	S	T
This parameter specifies the synchronous cycle in EtherCAT communication.							
P4.07 ¹	Data size	16bit	Data format	DEC			
	Modbus communication address	1814, 1815	CANopen communication address	0x2407, 0x00			
P4.08 ¹	EtherCAT synchronous type	Setting range	Default	Unit	Applicable mode		
		0-2	0	-	P	S	T
This parameter specifies the type of synchronization between the master and the slave in EtherCAT communication.							
		Set value	Meaning				
		[0]	Free-run				
		2	DC mode (sync0)				
P4.08 ¹	Data size	16bit	Data format	DEC			
	Modbus communication address	1816, 1817	CANopen communication address	0x2408, 0x00			
P4.09 ¹	EtherCAT fault detection time	Setting range	Default	Unit	Applicable mode		

		0-1000	100	ms	P	S	T
This parameter specifies the fault detection time in EtherCAT communication. Note: The value 0 indicates EtherCAT faults are not detected.							
P4.09 ¹	Data size	16bit	Data format	DEC			
	Modbus communication address	1818, 1819	CANopen communication address	0x2409, 0x00			

9.5.2 Servo types and communication control commands

P4.10 ¹	Upper computer type	Setting range	Default	Unit	Applicable mode		
		0-1	0	-	P	S	T
This parameter specifies the upper computer type which is identified by the drive control interface type of the upper computer.							
	Set value	Upper computer type	Control interface type				
	[0]	Pulse + analog	Position control/fully-closed-loop: pulse and PTP control Speed control/torque control: analog and internal settings				
	1	Communication bus	485 (protocol: Modbus) CAN (protocol: CANopen CiA301/402) PROFIBUS (protocol: PROFIBUS-DPV0)				
P4.10 ¹	Data size	16bit	Data format	DEC			
	Modbus communication address	1820, 1821	CANopen communication address	0x240A, 0x00			

P4.11*	Bus servo enabling	Setting range	Default	Unit	Applicable mode		
		0-1	0	-	P	S	T
This parameter specifies whether to enable the drive.							
	Set value	Function					
	[0]	Disable					
	1	Enable					
Note: If the drive is enabled by P0.04, the drive will be disabled if P4.11 is changed from 1							

to 0.				
P4.11*	Data size	16bit	Data format	DEC
	Modbus communication address	1822, 1823	CANopen communication address	0x240B, 0x00

P4.12*	Bus position command	Setting range	Default	Unit	Applicable mode		
		-(231-1)-(231-1)	0	reference unit	P	-	-

This parameter specifies the position command for the drive when P4.10 is set to 1.

P4.12*	Data size	32bit	Data format	DEC
	Modbus communication address	1824, 1825	CANopen communication address	0x240C, 0x00

P4.13*	Bus speed command	Setting range	Default	Unit	Applicable mode		
		-6000-6000	0	r/min	-	S	-

This parameter specifies the speed command for the drive when P4.10 is set to 1.

P4.13*	Data size	32bit	Data format	DEC
	Modbus communication address	1826, 1827	CANopen communication address	0x240D, 0x00

P4.14*	Bus torque command	Setting range	Default	Unit	Applicable mode		
		-500.0-500.0	0.0	%	-	-	T

This parameter specifies the torque command for the drive when P4.10 is set to 1.

P4.14*	Data size	16bit	Data format	DEC
	Modbus communication address	1828, 1829	CANopen communication address	0x240E, 0x00

P4.15*	Control mode switching command	Setting range	Default	Unit	Applicable mode		
		0-1	0	-	P	S	T

This parameter can be used to switch the control mode in hybrid control mode.

Set value	Function	Actual control mode	
		[0]	Disable
Position/torque	Position		
Position/torque	Speed		
1	Enable	Position/speed	Speed
		Position/torque	Torque
		Position/torque	Torque

Note: If the control mode switching command is updated, the actual switching process of the drive and motor is handled based on the settings of P0.90–P0.92 and actual feedback state.

P4.15*	Data size	16bit	Data format	DEC
	Modbus communication address	1830, 1831	CANopen communication address	0x240F, 0x00

P4.16*	Gain switching command	Setting range	Default	Unit	Applicable mode		
		0–1	0	-	P	S	T

This parameter specifies whether to enable gain switching for the drive. When P2.22, P2.27, and P2.31 are set to 2, the actual gain settings are used for switching.

Set value	Function	Actual gain
[0]	Disable	First gain setting
1	Enable	Second gain setting

P4.16*	Data size	16bit	Data format	DEC
	Modbus communication address	1832, 1833	CANopen communication address	0x2410, 0x00

P4.17*	Electronic gear ratio switching command	Setting range	Default	Unit	Applicable mode		
		0–3	0	-	P		

This parameter is used to switch electronic gear ratios for the drive when P4.10 is set to 1.

Set value	Numerator of actual electronic gear ratio	Denominator of actual electronic gear ratio
[0]	Numerator of electronic gear ratio 1 (P0.25)	Denominator of electronic gear ratio (P0.26)

	1	Numerator of electronic gear ratio 2 (P0.27)		
	2	Numerator of electronic gear ratio 3 (P0.28)		
	3	Numerator of electronic gear ratio 4 (P0.29)		
P4.17*	Data size	16bit	Data format	DEC
	Modbus communication address	1834, 1835	CANopen communication address	0x2411, 0x00

P4.18*	Inertia ratio switching command	Setting range	Default	Unit	Applicable mode		
		0-1	0	-	P	S	T

This parameter specifies whether to enable inertia ratio switching for the drive.

Set value	Function	Actual inertia ratio
[0]	Disable	Inertia ratio 1 (P1.01)
1	Enable	Inertia ratio 2 (P1.02)

P4.18*	Data size	16bit	Data format	DEC
	Modbus communication address	1836, 1837	CANopen communication address	0x2412, 0x00

P4.19*	Zero speed clamp command	Setting range	Default	Unit	Applicable mode		
		0-1	0	-	-	S	T

This parameter specifies whether to carry out zero speed clamp operation on the drive.

Set value	Function
[0]	Disable
1	Enable

P4.19*	Data size	16bit	Data format	DEC
	Modbus communication address	1838, 1839	CANopen communication address	0x2413, 0x00

P4.20*	Clearing residual pulses	Setting range	Default	Unit	Applicable mode		
		0-1	0	-	P	-	-

This parameter specifies whether to enable residual pulse clearing on the drive. P3.45 specifies the mode for clearing residual pulses. If residual pulses are cleared, R0.04 is changed to 0.

Set value	Function
[0]	Disable
1	Enable

P4.20*	Data size	16bit	Data format	DEC
	Modbus communication address	1840, 1841	CANopen communication address	0x2414, 0x00

P4.21*	Torque limit switching command	Setting range	Default	Unit	Applicable mode		
		0-1	0	-	P	S	T

This parameter specifies whether to enable torque limit switching for the drive.

Set value	Function
[0]	Disable
1	Enable

P4.21*	Data size	16bit	Data format	DEC
	Modbus communication address	1842, 1843	CANopen communication address	0x2415, 0x00

P4.22*	External fault command	Setting range	Default	Unit	Applicable mode		
		0-1	0	-	P	S	T

This parameter specifies whether to enable external fault reporting for the drive.

Set value	Function
[0]	Disable
1	Enable

P4.22*	Data size	16bit	Data format	DEC
	Modbus communication address	1844, 1845	CANopen communication address	0x2416, 0x00

P4.23*	Emergency stop	Setting range	Default	Unit	Applicable
--------	----------------	---------------	---------	------	------------

	command				mode		
		0-1	0	-	P	S	T
This parameter specifies whether to carry out emergency stop operation on the drive.							
	Set value	Function					
	[0]	Disable					
	1	Enable					
P4.23*	Data size	16bit	Data format	DEC			
	Modbus communication address	1846, 1847	CANopen communication address	0x2417, 0x00			
P4.24*	Input command of vibration control switching	Setting range	Default	Unit	Applicable mode		
		0-1	0	-	P	-	-
This parameter specifies whether to enable vibration control switching for the drive.							
	Set value	Function					
	[0]	Disable					
	1	Enable					
P4.24*	Data size	16bit	Data format	DEC			
	Modbus communication address	1848, 1849	CANopen communication address	0x2418, 0x00			
P4.25	EtherCAT control unit type	Setting range	Default	Unit	Applicable mode		
		0-3	1	-	P	S	-
This parameter specifies the EtherCAT control unit type							
	Set value	Meaning					
	0	Manufacturer unit					
	[1]	CIA402 Unit					
	2	CIA402 OMRON					
	3	CIA402 standard					
P4.25	Data size	16bit	Data format	DEC			
	Modbus	1850, 1851	CANopen	0x2419, 0x00			

	communication address		communication address				
P4.26	EtherCAT PDO input offset	Setting range	Default	Unit	Applicable mode		
		0-63	3	125µs	P	S	-
This parameter specifies the delay time for the PDO data to start taking effect after DC interruption, to avoid the command loss caused by large command cycle fluctuation.							
P4.26	Data size	16bit	Data format	DEC			
	Modbus communication address	1852, 1853	CANopen communication address	0x241A, 0x00			
P4.27	Compensation times of EtherCAT position interpolation mode	Setting range	Default	Unit	Applicable mode		
		0-10	0	-	P	S	-
This parameter specifies the max. number of times to compensate for a position command if the position command is not received in the position interpolation mode.							
P4.27	Data size	16bit	Data format	DEC			
	Modbus communication address	1854, 1855	CANopen communication address	0x241B, 0x00			
P4.28 ¹	EtherCAT digital output control enable	Setting range	Default	Unit	Applicable mode		
		0-1	0	-	P	S	-
The digital outputs are controlled via 0x60FE in EtherCAT mode.							
		Set value	Function				
		[0]	Disable				
		1	Enable				
P4.28 ¹	Data size	16bit	Data format	DEC			
	Modbus communication address	1856, 1857	CANopen communication address	0x241C, 0x00			
P4.29 ¹	EtherCAT main cycle setting	Setting range	Default	Unit	Applicable mode		

		0-1	0	-	P	S	-
This parameter specifies EtherCAT main cycle setting.							
		Set value	Meaning				
		[0]	1ms				
		1	10ms				
P4.29 ¹	Data size	16bit		Data format	DEC		
	Modbus communication address	1858, 1859		CANopen communication address	0x241D, 0x00		

9.5.3 Extension and application

P4.30	Stop mode	Setting range	Default	Unit	Applicable mode		
		0-3	0	-	P	S	T
When the servo is turned OFF and when fault alarm occurs, this parameter is used to set whether the dynamic brake works or not and the state of the servo motor after stop:							
		Set value of P4.30	Action				
			During deceleration	After stopping			
		[0]	Coast to stop	Keep the inertia running state			
		1	Dynamic brake to stop	Keep the inertia running state			
		2	Dynamic brake to stop	Dynamic braking state			
		3	External dynamic brake acting	Dynamic braking state			
		4	Quick stop	Dynamic braking state			
Note:							
<ul style="list-style-type: none"> If P4.30 is set to 1, the dynamic brake works when the motor speed is higher than the set value (30 r/min by default) of P3.58, and the dynamic brake is switched off when the motor speed is lower than the set value of P3.58. After the motor stops, the dynamic brake does not work. If P4.30 is set to 4, when enabling is stopped or a non-fatal fault (faults other than 1-0 or 1-5) occurs, a shutdown will be performed according to P0.69 with constant enabling during the fast shutdown. If the servo motor runs at a speed higher than the rated one, you cannot enable the dynamic brake. If the servo motor runs at a high speed with a large inertia load, exercise 							

caution before using the dynamic brake. Do not restart the dynamic brake frequently. Otherwise, the servo drive may be damaged.

- When 5.5kW and 7.5kW servo drives use the dynamic braking function, the rotating inertia ratio of the load is required to be less than 500% at the rated speed of the motor. The inertia ratio obtained through drive inertia autotuning shall prevail.

P4.30	Data size	16bit	Data format	DEC
	Modbus communication address	1860, 1861	CANopen communication address	0x241E, 0x00

P4.31	Max. speed limit	Setting range	Default	Unit	Applicable mode		
		0-20000	5000	r/min	P	S	T

This parameter specifies the maximum speed of the servo motor. If the absolute value of the speed command is greater than the setting of this parameter, the actually-set speed is limited by this parameter, and the actual direction is the same as that in the original speed command. This parameter is valid in all modes.

Note: The default value and setting range of this parameter are associated with the drive power class.

P4.31	Data size	16bit	Data format	DEC
	Modbus communication address	1862, 1863	CANopen communication address	0x241F, 0x00

P4.32	Overspeed threshold	Setting range	Default	Unit	Applicable mode		
		0-20000	6000	r/min	P	S	T

This parameter specifies the overspeed level for the servo motor. When the motor runs at a speed higher than the setting of this parameter, an overspeed fault alarm is reported.

Note: The default value and setting range of this parameter are associated with the drive power class.

P4.32	Data size	16bit	Data format	DEC
	Modbus communication address	1864	CANopen communication address	0x2420, 0x00



P4.33	Pulse threshold of position deviation	Setting range	Default	Unit	Applicable mode		
-------	---------------------------------------	---------------	---------	------	-----------------	--	--

		0-227	100000	reference unit	P	-	-
This parameter specifies the alarm threshold for the position deviation (Er22-0). In position mode, when the number of the residual pulses exceed the setting of this parameter, the fault alarm is reported. When P4.33=0, it means position deviation will not be detected.							
P4.33	Data size	32bit	Data format		DEC		
	Modbus communication address	1866, 1867	CANopen communication address		0x2421, 0x00		

P4.34 ¹	Brake overload detection selection	Setting range	Default	Unit	Applicable mode		
		0-4	4	-	P	S	T
This parameter specifies the regenerative brake mode and overload protection mode.							
		Set value	Regenerative brake and overload protection				
		0	Disable (no regenerative brake)				
		1	Built-in				
		2	External				
		3	Built-in (First-order thermal model)				
		[4]	Built-in (Second-order thermal model)				
P4.34 ¹	Data size	16bit	Data format		DEC		
	Modbus communication address	1868, 1869	CANopen communication address		0x2422, 0x00		

P4.35	Enable out-of-control speed detection	Setting range	Default	Unit	Applicable mode		
		0-1	1	-	P	S	T
This parameter specifies whether out-of-control speed detection is enabled.							
		Set value	Function				
		0	Disable				
		[1]	Enable				
P4.35	Data size	16bit	Data format		DEC		
	Modbus communication address	1870, 1871	CANopen communication address		0x2423, 0x00		

P4.36 ¹	Main power UV protection	Setting range	Default	Unit	Applicable mode								
		0-1	1	-	P	S	T						
<p>This parameter specifies whether the drive reports a main circuit undervoltage alarm when the main power encounters a main circuit undervoltage fault.</p> <table border="1"> <thead> <tr> <th>Set value</th> <th>Protection</th> </tr> </thead> <tbody> <tr> <td>0</td> <td>In servo enabling state, the drive does not report the fault Er13-1 when main circuit undervoltage occurs.</td> </tr> <tr> <td>[1]</td> <td>In servo enabling state, the drive reports the fault Er13-1 and stops when main circuit undervoltage occurs.</td> </tr> </tbody> </table>								Set value	Protection	0	In servo enabling state, the drive does not report the fault Er13-1 when main circuit undervoltage occurs.	[1]	In servo enabling state, the drive reports the fault Er13-1 and stops when main circuit undervoltage occurs.
Set value	Protection												
0	In servo enabling state, the drive does not report the fault Er13-1 when main circuit undervoltage occurs.												
[1]	In servo enabling state, the drive reports the fault Er13-1 and stops when main circuit undervoltage occurs.												
P4.36 ¹	Data size	16bit	Data format	DEC									
	Modbus communication address	1872, 1873	CANopen communication address	0x2424, 0x00									
P4.37	Main power UV detection time	Setting range	Default	Unit	Applicable mode								
		70-2000	70	ms	P	S	T						
<p>This parameter specifies the time taken to detect main power undervoltage.  Note: The value 2000 indicates the function of detecting main power undervoltage is invalid.</p>													
P4.37	Data size	16bit	Data format	DEC									
	Modbus communication address	1874, 1875	CANopen communication address	0x2425, 0x00									
P4.38	Motor overload rate	Setting range	Default	Unit	Applicable mode								
		0.0-500.0	115.0	%	P	S	T						
<p>This parameter specifies the motor overload rate. Note: The default value is 115.0%. When increasing the value of this parameter, please take the motor overload capacity into consideration.</p>													
P4.38	Data size	16bit	Data format	DEC									
	Modbus communication address	1876, 1877	CANopen communication address	0x2426, 0x00									

P4.39	Speed deviation setting	Setting range	Default	Unit	Applicable mode		
		0-20000	0	r/min	P	S	-
<p>This parameter specifies the condition for detecting the speed deviation fault. If the absolute value of the actual speed command minus the motor speed is greater than the setting of this parameter and the deviation lasts more than 100ms, a speed deviation alarm is reported.</p> <p> Note: The value 0 indicates the speed deviation fault will not be detected.</p>							
P4.39	Data size	16bit	Data format	DEC			
	Modbus communication address	1878, 1879	CANopen communication address	0x2427, 0x00			
P4.40	Forward speed limit	Setting range	Default	Unit	Applicable mode		
		0-20000	20000	r/min	P	S	T
<p>This parameter specifies the maximum limit on the forward speed command.</p> <p> Note: The default value and setting range of this parameter are associated with the drive power class.</p>							
P4.40	Data size	16bit	Data format	DEC			
	Modbus communication address	1880, 1881	CANopen communication address	0x2428, 0x00			
P4.41	Reverse speed limit	Setting range	Default	Unit	Applicable mode		
		-20000-0	-20000	r/min	P	S	T
<p>This parameter specifies the maximum limit on the reverse speed command.</p> <p> Note: The default value and setting range of this parameter are associated with the drive power class.</p>							
P4.41	Data size	16bit	Data format	DEC			
	Modbus communication address	1882, 1883	CANopen communication address	0x2429, 0x00			
P4.42	Internal speed with high resolution	Setting range	Default	Unit	Applicable mode		
		-20000.0-20000.0	0.0	r/min	-	S	-
<p>This parameter specifies the internal speed with high resolution.</p>							

P4.42	Data size	32bit	Data format	DEC
	Modbus communication address	1884, 1885	CANopen communication address	0x242A, 0x00

P4.43 ¹	EtherCAT-related control	Setting range	Default	Unit	Applicable mode		
		0-3FFF	2183	-	P	S	T

1. Bit 0: Screen out torque limit (60E0h, 60E1h) command. 1 is by default, screen out.
2. Bit 1: Screen out speed limit (607Fh) command, 1 is by default, screen out (not controlled by this bit in torque mode, always valid).
3. Bits 2-3: Reserved.
4. Bit 4: Whether to use 60B1h as speed feed-forward, 0 is by default, use servo internal speed as feed-forward.
5. Bit 5: Whether to use 60B0h as position feed-forward, 0 is by default, not used.
6. Bit 6: 607Dh action range, 0 is by default, and valid only in position mode.
7. Bit 7: Position command processing after limiting is valid, 0 is by default, and position command is discarded.
8. Bit 8: EtherCAT running cycle, 0 is by default, running in main interrupt.
9. Bits 9-11: Reserved.
10. Bit 12: 0x60FD resolution, 0 is by default, standard CIA402 protocol; 1: Customized.
11. Bits 13-15: Reserved.

P4.43 ¹	Data size	16bit	Data format	HEX
	Modbus communication address	1886, 1887	CANopen communication address	0x242B, 0x00

P4.44 ¹	Out-of-control speed threshold	Setting range	Default	Unit	Applicable mode		
		0-20000	600	r/min	P	S	T

This parameter specifies the out-of-control speed threshold. Stall judgment is performed when the actual speed is greater than the set value.

P4.44 ¹	Data size	16bit	Data format	DEC
	Modbus communication address	1888, 1889	CANopen communication address	0x242C, 0x00

P4.45	Fault mask bit setting	Setting range	Default	Unit	Applicable mode
-------	------------------------	----------------------	----------------	-------------	------------------------

		0x0000–0x7FFF	0x0000	-	P	S	T
<p>This parameter specifies whether to shield some faults. Bit 0: Motor code check fault shielding, 0: Not shield; 1: Shield Bits 1–14: Reserved</p>							
P4.45	Data size	16bit	Data format	HEX			
	Modbus communication address	1890, 1891	CANopen communication address	0x242D, 0x00			
P4.50 ¹	Encoder phase-Z offset	Setting range	Default	Unit	Applicable mode		
		0–(2 ²⁰ -1)	0	pulse	P	S	T
<p>This parameter specifies the output position of phase Z. The phase-Z offset is the pulses in the CCW direction.</p>							
P4.50 ¹	Data size	32bit	Data format	DEC			
	Modbus communication address	1900, 1901	CANopen communication address	0x2432, 0x00			
P4.51	Torque limit switching time 1	Setting range	Default	Unit	Applicable mode		
		0–4000	0	ms/(100%)	P	S	-
<p>This parameter specifies the time taken to switch from the first torque limit to the second torque limit.</p>							
P4.51	Data size	16bit	Data format	DEC			
	Modbus communication address	1902, 1903	CANopen communication address	0x2433, 0x00			
P4.52	Torque limit switching time 2	Setting range	Default	Unit	Applicable mode		
		0–4000	0	ms/(100%)	P	S	-
<p>This parameter specifies the time taken to switch from the second torque limit to the first torque limit.</p>							
P4.52	Data size	16bit	Data format	DEC			
	Modbus communication address	1904, 1905	CANopen communication address	0x2434, 0x00			

P4.53	Current loop response adjustment	Setting range	Default	Unit	Applicable mode		
		10.0–200.0	100.0	%	P	S	T
This parameter specifies the adjustment coefficient of current loop response width.							
P4.53	Data size	16bit	Data format	DEC			
	Modbus communication address	1906, 1907	CANopen communication address	0x2435, 0x00			
P4.54 ¹	Delay after power-on initialization	Setting range	Default	Unit	Applicable mode		
		0–200000	0	ms	P	S	T
This parameter specifies the delay time of servo enabling after power-on initialization is completed.							
P4.54 ¹	Data size	32bit	Data format	DEC			
	Modbus communication address	1908, 1909	CANopen communication address	0x2436, 0x00			
P4.77	Detection time for motor phase loss	Setting range	Default	Unit	Applicable mode		
		0–800	200	ms	P	S	T
Detection time for motor phase loss is valid when it is set to a non-zero value.							
P4.77	Data size	16bit	Data format	DEC			
	Modbus communication address	1954, 1955	CANopen communication address	0x244D, 0x00			
P4.78	Motor overtemperature protection threshold	Setting range	Default	Unit	Applicable mode		
		0–200	0	°C	P	S	T
Temperature sampling from temperature resistors PT100 and KTY84-130 is supported. If the temperature exceeds the setting of this parameter, a motor overtemperature (OT) fault is reported. The value 0 indicates temperature sampling is not conducted.							
P4.78	Data size	16bit	Data format	DEC			
	Modbus communication address	1956, 1957	CANopen communication address	0x244E, 0x00			

P4.79	Quick stop method	Setting range	Default	Unit	Applicable mode		
		0-2	2	-	P	S	T
0: Stop enabling automatically after fast stop to zero speed (the upper computer needs to be re-enabled); 1: Stop enabling automatically after fast stop to zero speed and report Er10-4 fault; 2: Default, fast stop zero speed clamp.							
P4.79	Data size	16bit	Data format	DEC			
	Modbus communication address	1958, 1959	CANopen communication address	0x244F, 0x00			

9.5.4 Special commands

P4.90*	Fault recovery	Setting range	Default	Unit	Applicable mode								
		0-1	0	-	P	S	T						
This parameter can be set by the upper computer via communication mode to clear the drive fault.													
		<table border="1"> <thead> <tr> <th>Set value</th> <th>Function</th> </tr> </thead> <tbody> <tr> <td>[0]</td> <td>Disable</td> </tr> <tr> <td>1</td> <td>Enable</td> </tr> </tbody> </table>						Set value	Function	[0]	Disable	1	Enable
Set value	Function												
[0]	Disable												
1	Enable												
<p>Note:</p> <ul style="list-style-type: none"> If fault recovery command is enabled, the servo is not enabled for the drive, and the fault occurring condition is not triggered, the fault that can be automatically cleared recovers automatically. Other faults cannot be automatically cleared online but can be cleared after repower-on. You can set this parameter on the LED panel to clear faults. 													
P4.90*	Data size	16bit	Data format	DEC									
	Modbus communication address	1980, 1981	CANopen communication address	0x245A, 0x00									
P4.91*	Parameter saving	Setting range	Default	Unit	Applicable mode								
		0-1	0	-	P	S	T						
If P0.17 is set to 1 (saving in batches), this parameter can be used to send a parameter saving command so that any parameter modification can be written to the EEPROM.													

		Set value	Function				
		[0]	Disable				
		1	Enable				
P4.91*	Data size	16bit		Data format	DEC		
	Modbus communication address	1982, 1983		CANopen communication address	0x245B, 0x00		
P4.92*	Restore to default values	Setting range	Default	Unit	Applicable mode		
		0-1	0	-	P	S	T
This parameter specifies whether to enable the function of restoring factory settings. If the function is enabled, all user parameters (P0-P6 group) are restored to factory settings.							
		Set value	Function				
		[0]	Disable				
		1	Enable				
P4.92*	Data size	16bit		Data format	DEC		
	Modbus communication address	1984, 1985		CANopen communication address	0x245C, 0x00		
P4.93*	Read fault records	Setting range	Default	Unit	Applicable mode		
		0-1	0	-	P	S	T
This parameter specifies whether to enable the function of reading fault records. If the function is enabled, the fault records specified by P4.95 are read and displayed.							
		Set value	Function				
		[0]	Disable				
		1	Enable				
P4.93*	Data size	16bit		Data format	DEC		
	Modbus communication address	1986, 1987		CANopen communication address	0x245D, 0x00		

P4.94*	Clear fault records	Setting range	Default	Unit	Applicable mode								
		0-1	0	-	P	S	T						
<p>This parameter specifies whether to enable the function of clearing fault records. If the function is enabled, all the fault records are cleared.</p> <table border="1"> <thead> <tr> <th>Set value</th> <th>Function</th> </tr> </thead> <tbody> <tr> <td>[0]</td> <td>Disable</td> </tr> <tr> <td>1</td> <td>Enable</td> </tr> </tbody> </table>								Set value	Function	[0]	Disable	1	Enable
Set value	Function												
[0]	Disable												
1	Enable												
P4.94*	Data size	16bit	Data format	DEC									
	Modbus communication address	1988, 1989	CANopen communication address	0x245E, 0x00									
P4.95*	Group number of the fault record	Setting range	Default	Unit	Applicable mode								
		0-9	0	-	P	S	T						
<p>This parameter specifies the group number of fault records that are read. The value 0 indicates the fault records in group 1 are read and the faults have occurred most recently. The value 9 indicates the fault records in group 10 are read and the faults have occurred earliest.</p>													
P4.95*	Data size	16bit	Data format	DEC									
	Modbus communication address	1990, 1991	CANopen communication address	0x245F, 0x00									
P4.96*	Encoder initial angle test	Setting range	Default	Unit	Applicable mode								
		0-4	0	-	P	S	T						
<p>This parameter specifies the encoder initial angle test. If it is absolute encoder, the motor initial angle will be written to the encoder EEPROM. Note: No load can be connected to the motor output shaft.</p>													
P4.96*	Data size	16bit	Data format	DEC									
	Modbus communication address	1992, 1993	CANopen communication address	0x2460, 0x00									
P4.97*	EEPROM operation of communication encoder	Setting range	Default	Unit	Applicable mode								

		0-1	0	-	P	S	T
This parameter specifies whether to write all motor-related parameters to the EEPROM equipped with the communication encoder. In any following startup, the drive uses the data in the EEPROM for parameter initialization.							
P4.97*	Data size	16bit	Data format		DEC		
	Modbus communication address	1994, 1995	CANopen communication address		0x2461, 0x00		

P4.98	EEPROM data fault block of communication encoder	Setting range	Default	Unit	Applicable mode		
		0-1	0	-	P	S	T
This parameter is used to screen the fault of no data or wrong data in the communication encoder EEPROM. When a fault code of Er2-c or Er2-d occurs, you need to set the correct motor model and you can continue to use the motor after re-powerin-on. At this time, the drive will use the motor data in the drive EEPROM to initialize the relevant parameters.							
P4.98	Data size	16bit	Data format		DEC		
	Modbus communication address	1996, 1997	CANopen communication address		0x2462, 0x00		

9.5.5 Frequency-division output and second encoder settings

P4.58 ¹	Z pulse width of frequency-division output	Setting range	Default	Unit	Applicable mode		
		1-255	2	pulse	P	S	T
This parameter specifies the Z pulse width of frequency-division output; valid only when P4.69=0 [normal frequency-division output].							
P4.58 ¹	Data size	16bit	Data format		DEC		
	Modbus communication address	1916, 1917	CANopen communication address		0x243A, 0x00		
P4.59	Z pulse offset of frequency-division output	Setting range	Default	Unit	Applicable mode		
		0-(2 ³¹ -1)	0	pulse	P	S	T
This parameter specifies the Z pulse offset of frequency-division output. The max. offset							

cannot exceed the single-turn resolution of frequency-division output. It is valid only when P4.69=0 [normal frequency-division output].

P4.59	Data size	32bit	Data format	DEC
	Modbus communication address	1918, 1919	CANopen communication address	0x243B, 0x00

P4.60 ¹	Frequency-division numerator of external linear encoder	Setting range	Default	Unit	Applicable mode		
		1-(2 ³¹ -1)	10000	-	P	-	-

This parameter specifies the frequency-division numerator of the external linear encoder.

P4.60 ¹	Data size	32bit	Data format	DEC
	Modbus communication address	1920, 1921	CANopen communication address	0x243C, 0x00

P4.61 ¹	Frequency-division denominator of external linear encoder	Setting range	Default	Unit	Applicable mode		
		1-(2 ³¹ -1)	10000	-	P	-	-

This parameter specifies the frequency-division denominator of the external linear encoder. It corresponds to the linear encoder pulses needed for each motor rotation.

P4.61 ¹	Data size	32bit	Data format	DEC
	Modbus communication address	1922, 1923	CANopen communication address	0x243D, 0x00

P4.62 ¹	Direction reversal of external linear encoder	Setting range	Default	Unit	Applicable mode		
		0-1	0	-	P	-	-

This parameter is used to set the direction reversal of external linear encoder feedback counting.

Set value	Function
[0]	Use the count from the external linear encoder directly.
1	Reverse the count from the external linear encoder and then use the reversed count.

P4.62 ¹	Data size	16bit	Data format	DEC
	Modbus	1924, 1925	CANopen	0x243E, 0x00

	communication address		communication address		
P4.64 ¹	Hybrid control deviation limit	Setting range	Default	Unit	Applicable mode
		1-2 ²⁷	160000	pulse	P - -
In the fully-closed loop control, set the tolerance (mixed deviation) between the user unit (reference unit) corresponding to the encoder feedback position and user unit (reference unit) corresponding to the linear encoder feedback position. If R0.05 exceeds the setting value, the drive will report Er22-1.					
P4.64 ¹	Data size	32bit	Data format	DEC	
	Modbus communication address	1928, 1929	CANopen communication address	0x2440, 0x00	
P4.65 ¹	Threshold for hybrid-control deviation clearing	Setting range	Default	Unit	Applicable mode
		0-100	0	rotations	P - -
This parameter specifies the condition for clearing the hybrid-control deviation. When the motor rotation number reaches the specified one, the hybrid-control deviation is cleared. The value 0 indicates the hybrid-control deviation is not cleared.					
P4.65 ¹	Data size	16bit	Data format	DEC	
	Modbus communication address	1930, 1931	CANopen communication address	0x2441, 0x00	
P4.67 ¹	External grating pulse output mode of phase AB	Setting range	Default	Unit	Applicable mode
		0-1	0	-	P - -
It is used to set the signal source of pulse feedback output when fully-closed loop function is enabled under position mode.					
		Set value	Pulse feedback signal source		
		[0]	Encoder feedback		
		1	Linear encoder feedback		
P4.67 ¹	Data size	16bit	Data format	DEC	
	Modbus communication	1934, 1935	CANopen communication	0x2443, 0x00	

	address		address	
--	---------	--	---------	--

P4.68 ¹	External linear encoder (or encoder 2) resolution	Setting range	Default	Unit	Applicable mode		
		1-(2 ³¹ -1)	10000	pulse	P	-	-

This parameter specifies the resolution of the external linear encoder (or second encoder). If the second encoder is connected, the output is the pulses needed for each encoder rotation.

P4.68 ¹	Data size	32bit	Data format	DEC
	Modbus communication address	1936, 1937	CANopen communication address	0x2444, 0x00

P4.69 ¹	Frequency division output source	Setting range	Default	Unit	Applicable mode		
		0-4	0	-	P	S	T

This parameter specifies the signal source of frequency division output.

Set value	Pulse feedback signal source
[0]	Normal frequency-division output
1	Second encoder bypass
2	Quadrature pulse input bypass in phases A and B
3	Internal virtual shaft
4	First encoder bypass (valid only for incremental encoders)

P4.69 ¹	Data size	32bit	Data format	DEC
	Modbus communication address	1938, 1939	CANopen communication address	0x2445, 0x00

P4.70 ¹	External linear encoder (second encoder) Z signal type	Setting range	Default	Unit	Applicable mode		
		0-3	0	-	P	S	T

As Z signal width is divided into 1/4, 1/2 and 1/1, the starting phase of the signal for each width corresponds to 4 kinds of AB levels, so there are in total 12 kinds of combinations. However, in order to adapt to these combinations and ensure the capture value is normal in both forward and reverse directions, it is necessary to set the AB state value corresponds to the middle of Z signal high level. For 1/4 and 1/2, they require any one of AB states during high level period after Z type signal setting; for 1/1 width encoder, the set Z type must be the AB value corresponds to the middle of high level.

P4.70 ¹	Data size	16bit	Data format	DEC
--------------------	-----------	-------	-------------	-----

	Modbus communication address	1940, 1941	CANopen communication address	0x2446, 0x00			
P4.75	User-defined control word (PROFIdrive)	Setting range	Default	Unit	Applicable mode		
		0-3	0	-	P	S	T
Default: 0: No function. 1: Torque command bias (P2.44), 16-bit signed number, 0x4000=P8.03 (Rated torque); 2: Speed feed-forward, 16-bit signed number, 0x4000=P8.02 (Rated speed), while P2.10 (Speed feed-forward gain) is valid. 3: IO output control, the last 4 bits are valid, need to be enabled by P4.28.							
P4.75	Data size	16bit	Data format	DEC			
	Modbus communication address	1950, 1951	CANopen communication address	0x244B, 0x00			
P4.76	User-defined state word (PROFIdrive)	Setting range	Default	Unit	Applicable mode		
		0-4	3	-	P	S	T
Default 3: IO input. 0: No function. 1: Current torque, 16-bit signed number, 0x4000=P8.03 (Rated torque). 2: Output current (absolute value), 0x4000=P8.01 (Rated current). 4: IO output state.							
P4.76	Data size	16bit	Data format	DEC			
	Modbus communication address	1952, 1953	CANopen communication address	0x244C, 0x00			
P4.80	PZD setting parameter 1 configuration	Setting range	Default	Unit	Applicable mode		
		1000-3999	1998	-	P	S	T
This parameter specifies the mapping content of setting parameter 1 in the PROFIBUS-DP communication process data (PZD), (1998 corresponds to the reserved parameter).							
P4.80	Data size	16bit	Data format	DEC			
	Modbus communication address	1960, 1961	CANopen communication address	0x2450, 0x00			







P4.81	PZD setting parameter 2 configuration	Setting range	Default	Unit	Applicable mode		
		1000–3999	1998	-	P	S	T
This parameter specifies the mapping content of setting parameter 2 in the PROFIBUS-DP communication process data (PZD), (1998 corresponds to the reserved parameter).							
P4.81	Data size	16bit	Data format		DEC		
	Modbus communication address	1962, 1963	CANopen communication address		0x2451, 0x00		
P4.82	PZD setting parameter 3 configuration	Setting range	Default	Unit	Applicable mode		
		1000–3999	1998	-	P	S	T
This parameter specifies the mapping content of setting parameter 3 in the PROFIBUS-DP communication process data (PZD), (1998 corresponds to the reserved parameter).							
P4.82	Data size	16bit	Data format		DEC		
	Modbus communication address	1964, 1965	CANopen communication address		0x2452, 0x00		
P4.83	PZD feedback parameter 1 configuration	Setting range	Default	Unit	Applicable mode		
		4000–5852	4012	-	P	S	T
This parameter specifies the mapping content of feedback parameter 1 in the PROFIBUS-DP communication process data (PZD), (4012 corresponds to R0.04[Residual pulses]).							
P4.83	Data size	16bit	Data format		DEC		
	Modbus communication address	1966, 1967	CANopen communication address		0x2453, 0x00		
P4.84	PZD feedback parameter 2 configuration	Setting range	Default	Unit	Applicable mode		
		4000–5852	4018	-	P	S	T
This parameter specifies the mapping content of feedback parameter 2 in the PROFIBUS-DP communication process data (PZD), (4018 corresponds to R0.07[Main circuit DC voltage]).							
P4.84	Data size	16bit	Data format		DEC		
	Modbus communication address	1968, 1969	CANopen communication address		0x2454, 0x00		

P4.85	PZD feedback parameter 3 configuration	Setting range	Default	Unit	Applicable mode		
		4000–5852	4032	-	P	S	T
This parameter specifies the mapping content of feedback parameter 3 in the PROFIBUS-DP communication process data (PZD), (4032 corresponds to R0.14[Rotor position relative to Z pulse].							
P4.85	Data size	16bit	Data format	DEC			
	Modbus communication address	1970, 1971	CANopen communication address	0x2455, 0x00			
P4.86	CANopen master heartbeat offset time	Setting range	Default	Unit	Applicable mode		
		0–200	2	-	P	S	T
This parameter specifies the CANopen master heartbeat offset time.							
P4.86	Data size	16bit	Data format	DEC			
	Modbus communication address	1972, 1973	CANopen communication address	0x2456, 0x00			
P4.87	CANopen communication cycle	Setting range	Default	Unit	Applicable mode		
		0–(2 ³¹ -1)	0	μs	P	S	T
This parameter specifies the synchronization signal cycle of a CANopen slave.  Note: The recommended unit is 1000μs.							
P4.87	Data size	32bit	Data format	DEC			
	Modbus communication address	1974, 1975	CANopen communication address	0x2457, 0x00			
P4.88	CANopen heartbeat cycle	Setting range	Default	Unit	Applicable mode		
		0–32767	1000	ms	P	S	T
This parameter specifies the heartbeat signal cycle of a CANopen slave.							
P4.88	Data size	16bit	Data format	DEC			
	Modbus communication address	1976, 1977	CANopen communication address	0x2458, 0x00			
P4.89	Automatic stop at CANopen	Setting range	Default	Unit	Applicable mode		

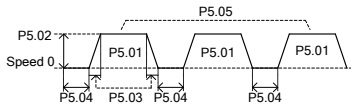
	disconnection	0-1	0	-	P	S	T
This parameter specifies whether to enable automatic stop when CANopen communication is disconnected.							
		Set value	Function				
		[0]	Disable				
		1	Enable				
P4.89	Data size	16bit	Data format	DEC			
	Modbus communication address	1978, 1979	CANopen communication address	0x2459, 0x00			

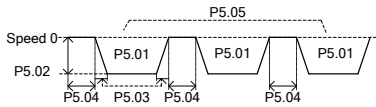
9.6 Program jog, homing, and PTP control (Group P5 parameters)

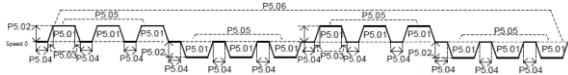
9.6.1 Program jog

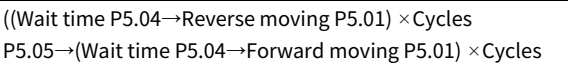
P5.00	Jog mode selection	Setting range	Default	Unit	Applicable mode		
		0-6	0	-	P	-	-
This parameter is used to set the program jog running mode:							
Mode	Key	Function					
[0]		(Wait time P5.04 → Forward moving P5.01) × Cycles P5.05 					
1		(Wait time P5.04 → Reverse moving P5.01) × Cycles P5.05 					
2		((Wait time P5.04 → Forward moving P5.01) × Cycles P5.05 → (Wait time P5.04 → Reverse moving P5.01) × Cycles P5.05) × Cycles 2 P5.06 					
3		((Wait time P5.04 → Reverse moving P5.01) × Cycles P5.05 → (Wait time P5.04 → Forward moving P5.01) × Cycles P5.05) × Cycles 2 P5.06 					

4		(Wait time P5.04→Forward moving P5.01→Wait time P5.04→Reverse moving P5.01) × Cycles P5.05
5		(Wait time P5.04→Reverse moving P5.01→Wait time P5.04→Forward moving P5.01) × Cycles P5.05
6	or	(Wait time P5.04→Forward/reverse moving P5.01) × 1 cycle

P5.00	Data size	16bit	Data format	DEC
	Modbus communication address	2000, 2001	CANopen communication address	0x2500, 0x00

P5.01	JOG movement amount	Setting range	Default	Unit	Applicable mode		
		1-2 ³⁰	50000	reference unit	P	-	-

This parameter specifies the increment of the position movement at jogging.

P5.01	Data size	32bit	Data format	DEC
	Modbus communication address	2002, 2003	CANopen communication address	0x2501, 0x00

P5.02	Jogging speed setting	Setting range	Default	Unit	Applicable mode		
		1-5000	500	r/min	P	-	-

This parameter specifies the maximum running speed at jogging.

P5.02	Data size	16bit	Data format	DEC		
	Modbus communication address	2004, 2005	CANopen communication address	0x2502, 0x00		

P5.03	Jogging ACC/DEC time	Setting range	Default	Unit	Applicable mode		
		2-10000	100	ms	P	-	-

This parameter specifies the acceleration or deceleration time at jogging. The setting of this parameter corresponds to the time taken to accelerate from the zero speed to the rated rotation speed. If you need to improve the speed from zero to 50% of the rated speed, the time taken to reach the target speed is 50% of the time specified by this parameter.

P5.03	Data size	16bit	Data format	DEC		
	Modbus communication address	2006, 2007	CANopen communication address	0x2503, 0x00		

P5.04	Jogging wait time	Setting range	Default	Unit	Applicable mode		
		0-10000	100	ms	P	-	-

This parameter specifies the wait time at jogging. The setting of this parameter corresponds to the time from jogging starting to the actual running or to the time taken to wait for next displacement after the current displacement.

P5.04	Data size	16bit	Data format	DEC		
	Modbus communication address	2008, 2009	CANopen communication address	0x2504, 0x00		

P5.05	Jogging cycle times	Setting range	Default	Unit	Applicable mode		
		0-10000	1	-	P	-	-

This parameter specifies the number of jogging cycles. For details, see the description for P5.00.

P5.05	Data size	16bit	Data format	DEC		
	Modbus communication address	2010, 2011	CANopen communication address	0x2505, 0x00		

P5.06	Jogging cycle times	Setting range	Default	Unit	Applicable mode		
		0-10000	1	-	P	-	-
This parameter specifies the number of jogging cycles. For details, see the description for P5.00.							
P5.06	Data size	16bit	Data format	DEC			
	Modbus communication address	2012, 2013	CANopen communication address	0x2506, 0x00			

9.6.2 Homing

P5.09	Homing ACC/DEC time	Setting range	Default	Unit	Applicable mode		
		0-6000000	0	ms	-	S	-
This parameter specifies Homing ACC/DEC time.							
P5.09	Data size	32bit	Data format	DEC			
	Modbus communication address	2018, 2019	CANopen communication address	0x2509, 0x00			

P5.10 ²	Homing mode	Setting range	Default	Unit	Applicable mode		
		0-128	0	-	P	-	-

This parameter specifies the homing mode.

Display mode: DEC

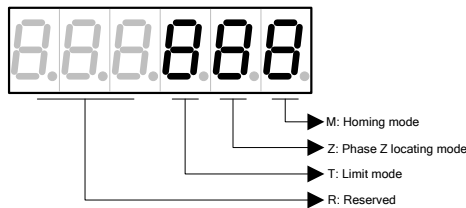

	R	T	Z	M
		Limit mode	Phase Z locating mode	Homing mode
Reserved		0-1	0-2	0-8
		T: Invalid	Z=0: Returning to locate phase Z is defined as the home	M=0: Forward rotation. The forward limit switch is the recurrent point.
		T: Invalid		M=1: Reverse rotation. The reverse

	Limit encountered: T=0: Report an offside fault. T=1: Reverse the direction.	position.	limit switch is the recurrent point.
		Z=1: Forwarding to locate phase Z is defined as the home position.	M=2: Forward rotation. The rising edge of the home switch is the recurrent point.
		Z=2: No locating phase Z. The recurrent point is defined as the home position.	M=3: Reverse rotation. The rising edge of the reverse limit switch is the recurrent point.
		Z: Invalid	M=4: Forward rotation. The first phase-Z signal is regarded as the home position.
		Z: Invalid	M=5: Reverse rotation. The first phase-Z signal is regarded as the home position.
		Z=0: Returning to locate phase Z is defined as the home position. Z=1: Forwarding to locate phase Z is defined as the home position. Z=2: No locating phase Z. The recurrent point is defined as the home position.	M=6: Forward rotation. The falling edge of the home switch is the recurrent point. M=7: Reverse rotation. The falling edge of the home switch is the recurrent point.
T: Invalid	Z: Invalid	M=8: The current position is defined as the home position.	

P5.10 ²	Data size	16bit	Data format	DEC
	Modbus communication address	2020, 2021	CANopen communication address	0x2505, 0x00

P5.11	Homing automatically after power-on and homing action method	Setting range	Default	Unit	Applicable mode		
		0-7FFF	0	-	P	-	-

1. Bit0–bit3 are used to set whether to return to the home position automatically after power-on. When it is set to 1, it will automatically return to the home position after powering on in enabled state and there is no fault.
2. Bit4–bit7 are used to set the processing method of the homing completion flag. 0: Keep the homing completion flag after the homing is complete, and the flag is lost after power off; 1: Clear the flag after jogging homing is complete; 2: The flag is saved at power off after the homing of the multi-turn absolute encoder is complete.
3. Bit8–bit11 are used to select the homing trigger mode (P5.15). 0: Level trigger, it is automatically set to 0 after the homing is complete; 1: Rising edge trigger, the value of P5.15 keeps unchanged after the homing is complete.
4. Bit12 is used to set the digital input homing action. Default: 0, the rising edge triggers the homing without stopping; 1: The falling edge stops the homing action.
5. Bit13 is used to enable the multi-turn absolute encoder ERR2-7 faults. Default: 0, disabled.
6. Bit14–bit15 are reserved.

P5.11	Data size	16bit	Data format	HEX
	Modbus communication address	2022, 2023	CANopen communication address	0x250B, 0x00

P5.12	High speed at homing step 1	Setting range	Default	Unit	Applicable mode		
		0–2000	100	r/min	P	-	-

This parameter specifies the high speed at step 1 of homing.

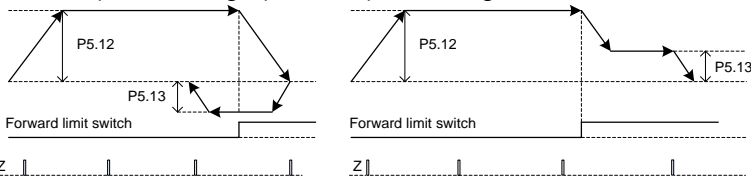

P5.12	Data size	16bit	Data format	DEC
	Modbus communication address	2024, 2025	CANopen communication address	0x250C, 0x00

P5.13	Low speed at homing step 2	Setting range	Default	Unit	Applicable mode		
		0–60	20	r/min	P	-	-

This parameter specifies the low speed at step 2 of homing. For details, see the diagram in the description for P5.12.

P5.13	Data size	16bit	Data format	DEC
-------	-----------	-------	-------------	-----

	Modbus communication address	2026, 2027	CANopen communication address	0x250D, 0x00
--	------------------------------	------------	-------------------------------	--------------

P5.14	Home setting	Setting range	Default	Unit	Applicable mode		
		-(2 ³¹ -1)-(2 ³¹ -1)	0	reference unit	P	-	-

This parameter is used to set the value of the home.

P5.14	Data size	32bit	Data format	DEC
	Modbus communication address	2028, 2029	CANopen communication address	0x250E, 0x00

P5.15*	Homing trigger command	Setting range	Default	Unit	Applicable mode		
		0-1	0	-	P	-	-

This parameter specifies whether to trigger the homing function. It has the same function as the homing trigger terminal with digital input.

P5.15*	Data size	16bit	Data format	DEC
	Modbus communication address	2030, 2031	CANopen communication address	0x250F, 0x00

P5.16	Homing associated action	Setting range	Default	Unit	Applicable mode		
		0-3	1	-	P	-	-

This parameter specifies the action associated with homing.

Set value	Description
0	No action.
[1]	The drive goes to the target position.
2	The drive goes to the position of segment 0.
3	The drive goes to the target position without homing.

P5.16	Data size	16bit	Data format	DEC
	Modbus communication address	2032, 2033	CANopen communication address	0x2510, 0x00

P5.17	Target speed after homing	Setting range	Default	Unit	Applicable mode		
		1-5000	100	r/min	P	-	-
This parameter specifies the target speed after homing. The change takes effect before homing.							
P5.17	Data size	16bit	Data format	DEC			
	Modbus communication address	2034, 2035	CANopen communication address	0x2511, 0x00			

P5.18	ACC/DEC time for target speed after homing	Setting range	Default	Unit	Applicable mode		
		0-32767	300	ms	P	-	-
This parameter specifies the acceleration or deceleration time taken to reach the target speed after homing. The setting of this parameter corresponds to the time taken to accelerate from the zero speed to the rated rotation speed. If you need to improve the speed from zero to 50% of the rated speed, the time taken to reach the target speed is 50% of the time specified by this parameter.							
P5.18	Data size	16bit	Data format	DEC			
	Modbus communication address	2036, 2037	CANopen communication address	0x2512, 0x00			

P5.19	Target position after homing	Setting range	Default	Unit	Applicable mode		
		$-(2^{31}-1)-(2^{31}-1)$	0	reference unit	P	-	-
This parameter specifies the target position after homing.							
P5.19	Data size	32bit	Data format	DEC			
	Modbus communication address	2038, 2039	CANopen communication address	0x2513, 0x00			

9.6.3 PTP control

P5.20*	PTP trigger signal	Setting range	Default	Unit	Applicable mode		
		-1-2048	-1	-	P	-	-
This parameter specifies whether to trigger the target segment. If data is written, PTP is triggered, and the internal buffer can receive 8 trigger signals at most.							

Trigger signal	Function
[-1]	Invalid
0-127	It triggers PTP control for PTPs 0-127, which equals the digital input of TRIG+POSn.
128-2047	Invalid
2048	Forcible stop.

Example: If segment signal 3 is written, segment program 3 is triggered.

P5.20*	Data size	16bit	Data format	DEC
	Modbus communication address	2040, 2041	CANopen communication address	0x2514, 0x00

P5.21	Target speed 00	Setting range	Default	Unit	Applicable mode		
		0-6000	20	r/min	P	-	-
P5.22	Target speed 01	Setting range	Default	Unit	Applicable mode		
		0-6000	50	r/min	P	-	-
P5.23	Target speed 02	Setting range	Default	Unit	Applicable mode		
		0-6000	100	r/min	P	-	-
P5.24	Target speed 03	Setting range	Default	Unit	Applicable mode		
		0-6000	200	r/min	P	-	-
P5.25	Target speed 04	Setting range	Default	Unit	Applicable mode		
		0-6000	300	r/min	P	-	-
P5.26	Target speed 05	Setting range	Default	Unit	Applicable mode		
		0-6000	500	r/min	P	-	-
P5.27	Target speed 06	Setting range	Default	Unit	Applicable mode		
		0-6000	600	r/min	P	-	-
P5.28	Target speed 07	Setting range	Default	Unit	Applicable mode		
		0-6000	800	r/min	P	-	-

P5.29	Target speed 08	Setting range	Default	Unit	Applicable mode		
		0-6000	1000	r/min	P	-	-
P5.30	Target speed 09	Setting range	Default	Unit	Applicable mode		
		0-6000	1300	r/min	P	-	-
P5.31	Target speed 10	Setting range	Default	Unit	Applicable mode		
		0-6000	1500	r/min	P	-	-
P5.32	Target speed 11	Setting range	Default	Unit	Applicable mode		
		0-6000	1800	r/min	P	-	-
P5.33	Target speed 12	Setting range	Default	Unit	Applicable mode		
		0-6000	2000	r/min	P	-	-
P5.34	Target speed 13	Setting range	Default	Unit	Applicable mode		
		0-6000	2300	r/min	P	-	-
P5.35	Target speed 14	Setting range	Default	Unit	Applicable mode		
		0-6000	2500	r/min	P	-	-
P5.36	Target speed 15	Setting range	Default	Unit	Applicable mode		
		0-6000	3000	r/min	P	-	-
This group of parameter specifies the target speed for each segment.							
P5.21	Data size	16bit	Data format	DEC			
	Modbus communication address	2042, 2043	CANopen communication address	0x2515, 0x00			
P5.22	Data size	16bit	Data format	DEC			
	Modbus communication address	2044, 2045	CANopen communication address	0x2516, 0x00			
P5.23	Data size	16bit	Data format	DEC			
	Modbus communication address	2046, 2047	CANopen communication address	0x2517, 0x00			
P5.24	Data size	16bit	Data format	DEC			
	Modbus	2048, 2049	CANopen	0x2518, 0x00			

	communication address		communication address	
P5.25	Data size	16bit	Data format	DEC
	Modbus communication address	2050, 2051	CANopen communication address	0x2519, 0x00
P5.26	Data size	16bit	Data format	DEC
	Modbus communication address	2052, 2053	CANopen communication address	0x251A, 0x00
P5.27	Data size	16bit	Data format	DEC
	Modbus communication address	2054, 2055	CANopen communication address	0x251B, 0x00
P5.28	Data size	16bit	Data format	DEC
	Modbus communication address	2056, 2057	CANopen communication address	0x251C, 0x00
P5.29	Data size	16bit	Data format	DEC
	Modbus communication address	2058, 2059	CANopen communication address	0x251D, 0x00
P5.30	Data size	16bit	Data format	DEC
	Modbus communication address	2060, 2061	CANopen communication address	0x251E, 0x00
P5.31	Data size	16bit	Data format	DEC
	Modbus communication address	2062, 2063	CANopen communication address	0x251F, 0x00
P5.32	Data size	16bit	Data format	DEC
	Modbus communication address	2064, 2065	CANopen communication address	0x2520, 0x00
P5.33	Data size	16bit	Data format	DEC
	Modbus communication address	2066, 2067	CANopen communication address	0x2521, 0x00
P5.34	Data size	16bit	Data format	DEC

	Modbus communication address	2068, 2069	CANopen communication address	0x2522, 0x00
P5.35	Data size	16bit	Data format	DEC
	Modbus communication address	2070, 2071	CANopen communication address	0x2523, 0x00
P5.36	Data size	16bit	Data format	DEC
	Modbus communication address	2072, 2073	CANopen communication address	0x2524, 0x00

P5.37	ACC/DEC time 00	Setting range	Default	Unit	Applicable mode		
		0-32767	200	ms	P	-	-
P5.38	ACC/DEC time 01	Setting range	Default	Unit	Applicable mode		
		0-32767	300	ms	P	-	-
P5.39	ACC/DEC time 02	Setting range	Default	Unit	Applicable mode		
		0-32767	500	ms	P	-	-
P5.40	ACC/DEC time 03	Setting range	Default	Unit	Applicable mode		
		0-32767	600	ms	P	-	-
P5.41	ACC/DEC time 04	Setting range	Default	Unit	Applicable mode		
		0-32767	800	ms	P	-	-
P5.42	ACC/DEC time 05	Setting range	Default	Unit	Applicable mode		
		0-32767	900	ms	P	-	-
P5.43	ACC/DEC time 06	Setting range	Default	Unit	Applicable mode		
		0-32767	1000	ms	P	-	-
P5.44	ACC/DEC time 07	Setting range	Default	Unit	Applicable mode		
		0-32767	1200	ms	P	-	-
P5.45	ACC/DEC time 08	Setting range	Default	Unit	Applicable mode		
		0-32767	1500	ms	P	-	-

P5.46	ACC/DEC time 09	Setting range	Default	Unit	Applicable mode		
		0-32767	2000	ms	P	-	-
P5.47	ACC/DEC time 10	Setting range	Default	Unit	Applicable mode		
		0-32767	2500	ms	P	-	-
P5.48	ACC/DEC time 11	Setting range	Default	Unit	Applicable mode		
		0-32767	3000	ms	P	-	-
P5.49	ACC/DEC time 12	Setting range	Default	Unit	Applicable mode		
		0-32767	5000	ms	P	-	-
P5.50	ACC/DEC time 13	Setting range	Default	Unit	Applicable mode		
		0-32767	8000	ms	P	-	-
P5.51	ACC/DEC time 14	Setting range	Default	Unit	Applicable mode		
		0-32767	50	ms	P	-	-
P5.52	ACC/DEC time 15	Setting range	Default	Unit	Applicable mode		
		0-32767	30	ms	P	-	-

This group of parameter specifies the acceleration or deceleration time for each segment.

P5.37	Data size	16bit	Data format	DEC
	Modbus communication address	2074, 2075	CANopen communication address	0x2525, 0x00
P5.38	Data size	16bit	Data format	DEC
	Modbus communication address	2076, 2077	CANopen communication address	0x2526, 0x00
P5.39	Data size	16bit	Data format	DEC
	Modbus communication address	2078, 2079	CANopen communication address	0x2527, 0x00
P5.40	Data size	16bit	Data format	DEC
	Modbus communication address	2080, 2081	CANopen communication address	0x2528, 0x00
P5.41	Data size	16bit	Data format	DEC

	Modbus communication address	2082, 2083	CANopen communication address	0x2529, 0x00
P5.42	Data size	16bit	Data format	DEC
	Modbus communication address	2084, 2085	CANopen communication address	0x252A, 0x00
P5.43	Data size	16bit	Data format	DEC
	Modbus communication address	2086, 2087	CANopen communication address	0x252B, 0x00
P5.44	Data size	16bit	Data format	DEC
	Modbus communication address	2088, 2089	CANopen communication address	0x252C, 0x00
P5.45	Data size	16bit	Data format	DEC
	Modbus communication address	2090, 2091	CANopen communication address	0x252D, 0x00
P5.46	Data size	16bit	Data format	DEC
	Modbus communication address	2092, 2093	CANopen communication address	0x252E, 0x00
P5.47	Data size	16bit	Data format	DEC
	Modbus communication address	2094, 2095	CANopen communication address	0x252F, 0x00
P5.48	Data size	16bit	Data format	DEC
	Modbus communication address	2096, 2097	CANopen communication address	0x2530, 0x00
P5.49	Data size	16bit	Data format	DEC
	Modbus communication address	2098, 2099	CANopen communication address	0x2531, 0x00
P5.50	Data size	16bit	Data format	DEC
	Modbus communication address	2100, 2101	CANopen communication address	0x2532, 0x00

P5.51	Data size	16bit	Data format	DEC
	Modbus communication address	2102, 2103	CANopen communication address	0x2533, 0x00
P5.52	Data size	16bit	Data format	DEC
	Modbus communication address	2104, 2105	CANopen communication address	0x2534, 0x00

P5.53	Delay time 00	Setting range	Default	Unit	Applicable mode		
		0-32767	0	ms	P	-	-
P5.54	Delay time 01	Setting range	Default	Unit	Applicable mode		
		0-32767	100	ms	P	-	-
P5.55	Delay time 02	Setting range	Default	Unit	Applicable mode		
		0-32767	200	ms	P	-	-
P5.56	Delay time 03	Setting range	Default	Unit	Applicable mode		
		0-32767	400	ms	P	-	-
P5.57	Delay time 04	Setting range	Default	Unit	Applicable mode		
		0-32767	500	ms	P	-	-
P5.58	Delay time 05	Setting range	Default	Unit	Applicable mode		
		0-32767	800	ms	P	-	-
P5.59	Delay time 06	Setting range	Default	Unit	Applicable mode		
		0-32767	1000	ms	P	-	-
P5.60	Delay time 07	Setting range	Default	Unit	Applicable mode		
		0-32767	1500	ms	P	-	-
P5.61	Delay time 08	Setting range	Default	Unit	Applicable mode		
		0-32767	2000	ms	P	-	-
P5.62	Delay time 09	Setting range	Default	Unit	Applicable mode		
		0-32767	2500	ms	P	-	-

P5.63	Delay time 10	Setting range	Default	Unit	Applicable mode		
		0-32767	3000	ms	P	-	-
P5.64	Delay time 11	Setting range	Default	Unit	Applicable mode		
		0-32767	3500	ms	P	-	-
P5.65	Delay time 12	Setting range	Default	Unit	Applicable mode		
		0-32767	4000	ms	P	-	-
P5.66	Delay time 13	Setting range	Default	Unit	Applicable mode		
		0-32767	4500	ms	P	-	-
P5.67	Delay time 14	Setting range	Default	Unit	Applicable mode		
		0-32767	5000	ms	P	-	-
P5.68	Delay time 15	Setting range	Default	Unit	Applicable mode		
		0-32767	5500	ms	P	-	-

This group of parameter specifies the delay time for each segment.

P5.53	Data size	16bit	Data format	DEC
	Modbus communication address	2106, 2107	CANopen communication address	0x2535, 0x00
P5.54	Data size	16bit	Data format	DEC
	Modbus communication address	2108, 2109	CANopen communication address	0x2536, 0x00
P5.55	Data size	16bit	Data format	DEC
	Modbus communication address	2110, 2111	CANopen communication address	0x2537, 0x00
P5.56	Data size	16bit	Data format	DEC
	Modbus communication address	2112, 2113	CANopen communication address	0x2538, 0x00
P5.57	Data size	16bit	Data format	DEC
	Modbus communication address	2114, 2115	CANopen communication address	0x2539, 0x00

P5.58	Data size	16bit	Data format	DEC
	Modbus communication address	2116, 2117	CANopen communication address	0x253A, 0x00
P5.59	Data size	16bit	Data format	DEC
	Modbus communication address	2118, 2119	CANopen communication address	0x253B, 0x00
P5.60	Data size	16bit	Data format	DEC
	Modbus communication address	2120, 2121	CANopen communication address	0x253C, 0x00
P5.61	Data size	16bit	Data format	DEC
	Modbus communication address	2122, 2123	CANopen communication address	0x253D, 0x00
P5.62	Data size	16bit	Data format	DEC
	Modbus communication address	2124, 2125	CANopen communication address	0x253E, 0x00
P5.63	Data size	16bit	Data format	DEC
	Modbus communication address	2126, 2127	CANopen communication address	0x253F, 0x00
P5.64	Data size	16bit	Data format	DEC
	Modbus communication address	2128, 2129	CANopen communication address	0x2540, 0x00
P5.65	Data size	16bit	Data format	DEC
	Modbus communication address	2130, 2131	CANopen communication address	0x2541, 0x00
P5.66	Data size	16bit	Data format	DEC
	Modbus communication address	2132, 2133	CANopen communication address	0x2542, 0x00
P5.67	Data size	16bit	Data format	DEC
	Modbus communication	2134, 2135	CANopen communication	0x2543, 0x00

	address		address	
P5.68	Data size	16bit	Data format	DEC
	Modbus communication address	2136, 2137	CANopen communication address	0x2544, 0x00

P5.69	PTP control buffer switch	Setting range	Default	Unit	Applicable mode		
		0-1	1	-	P	-	-

If buffering is enabled for PTP control, eight buffers can be received successively and executed sequentially.

P5.69	Data size	16bit	Data format	DEC
	Modbus communication address	2138, 2139	CANopen communication address	0x2545, 0x00

P5.70	Disk single-turn resolution	Setting range	Default	Unit	Applicable mode		
		$-(2^{31}-1)-(2^{31}-1)$	10000	pulse	P	-	-

This parameter specifies the single-turn resolution of the disk that the motor drives.

P5.70	Data size	32bit	Data format	DEC
	Modbus communication address	2140, 2141	CANopen communication address	0x2546, 0x00

P5.71	Disk homing switch	Setting range	Default	Unit	Applicable mode		
		0-3	0	-	P	-	-

This parameter specifies the homing mode of the disk.

P5.71	Data size	16bit	Data format	DEC
	Modbus communication address	2142, 2143	CANopen communication address	0x2547, 0x00

P5.72	Super multi-turn mode	Setting range	Default	Unit	Applicable mode		
		0-1	0	-	P	-	-

Note: When the servo motor rotates continuously in one direction, the multi-turn counting

overflow error may occur. The multi-turn encoder can only count 2^{16} turns normally, i.e., the super multi-turn mode. After this function is enabled, the number of turns counted by the multi-turn encoder can be extended from 16 bits to 32 bits.

Set value	Meaning
[0]	Normal mode
1	Super multi-turn mode

P5.72	Data size	16bit	Data format	DEC
	Modbus communication address	2144, 2145	CANopen communication address	0x2548, 0x00

P5.73	Digital trigger mode for PTP control	Setting range	Default	Unit	Applicable mode		
		0-1	0	-	P	-	-

Set value	Description
[0]	Binary input + Terminal trigger mode
1	Single terminal trigger mode (supporting 7 PTPs only)

P5.73	Data size	16bit	Data format	DEC
	Modbus communication address	2146, 2147	CANopen communication address	0x2549, 0x00

P5.74	Digital output mode for PTP control	Setting range	Default	Unit	Applicable mode		
		0-4	0	-	P	-	-

Set value	Description
[0]	Output before PTP arrival
1	Output after PTP arrival
2	Single-point output + Output before PTP arrival
3	Single-point output + Output after PTP arrival
4	Single-point output + Output after PTP arrival (only the control word in the absolute position supported)

P5.74	Data size	16bit	Data format	DEC
	Modbus	2148, 2149	CANopen	0x254A, 0x00

	communication address		communication address		
P5.75	PTP interruption pause enable	Setting range	Default	Unit	Applicable mode
		0-1	0	-	P - -
This parameter enables the PTP interruption pause function. When P5.75 is set to 1, PTP running pauses.					
P5.75	Data size	16bit	Data format	DEC	
	Modbus communication address	2150, 2151	CANopen communication address	0x254B, 0x00	
P5.76	Positioning compensation value 22	Setting range	Default	Unit	Applicable mode
		-2147483.646-2147483.647	0	-	P S T
This parameter specifies the positioning compensation value 22.					
P5.76	Data size	32bit	Data format	DEC	
	Modbus communication address	2152, 2153	CANopen communication address	0x254C, 0x00	
P5.77	Positioning compensation value 23	Setting range	Default	Unit	Applicable mode
		-2147483.646-2147483.647	0	-	P S T
This parameter specifies the positioning compensation value 23.					
P5.77	Data size	32bit	Data format	DEC	
	Modbus communication address	2154, 2155	CANopen communication address	0x254D, 0x00	
P5.78	Positioning compensation	Setting range	Default	Unit	Applicable mode

	value 24	-2147483.646– 2147483.647	0	-	P	S	T
This parameter specifies the positioning compensation value 24.							
P5.78	Data size	32bit	Data format	DEC			
	Modbus communication address	2156, 2157	CANopen communication address	0x254E, 0x00			
P5.79	Positioning compensation value 25	Setting range	Default	Unit	Applicable mode		
		-2147483.646– 2147483.647	0	-	P	S	T
This parameter specifies the positioning compensation value 25.							
P5.79	Data size	32bit	Data format	DEC			
	Modbus communication address	2158, 2159	CANopen communication address	0x254F, 0x00			
P5.80	Positioning compensation value 26	Setting range	Default	Unit	Applicable mode		
		-2147483.646– 2147483.647	0	-	P	S	T
This parameter specifies the positioning compensation value 26.							
P5.80	Data size	32bit	Data format	DEC			
	Modbus communication address	2160, 2161	CANopen communication address	0x2550, 0x00			
P5.81	Positioning compensation value 27	Setting range	Default	Unit	Applicable mode		
		-2147483.646– 2147483.647	0	-	P	S	T
This parameter specifies the positioning compensation value 27.							
P5.81	Data size	32bit	Data format	DEC			
	Modbus communication address	2162, 2163	CANopen communication address	0x2551, 0x00			

		address			address			
P5.82	Positioning compensation value 28	Setting range	Default	Unit	Applicable mode			
		-2147483.646–2147483.647	0	-	P	S	T	
This parameter specifies the positioning compensation value 28.								
P5.82	Data size	32bit	Data format		DEC			
	Modbus communication address	2164, 2165	CANopen communication address		0x2552, 0x00			
P5.83	Positioning compensation value 29	Setting range	Default	Unit	Applicable mode			
		-2147483.646–2147483.647	0	-	P	S	T	
This parameter specifies the positioning compensation value 29.								
P5.83	Data size	32bit	Data format		DEC			
	Modbus communication address	2166, 2167	CANopen communication address		0x2553, 0x00			
P5.84	Positioning compensation value 30	Setting range	Default	Unit	Applicable mode			
		-2147483.646–2147483.647	0	-	P	S	T	
This parameter specifies the positioning compensation value 30.								
P5.84	Data size	32bit	Data format		DEC			
	Modbus communication address	2168, 2169	CANopen communication address		0x2554, 0x00			
P5.85	Positioning compensation value 31	Setting range	Default	Unit	Applicable mode			
		-2147483.646–2147483.647	0	-	P	S	T	
This parameter specifies the positioning compensation value 31.								
P5.85	Data size	32bit	Data format		DEC			
	Modbus	2170, 2171	CANopen		0x2555, 0x00			

	communication address		communication address		
P5.86	Positioning compensation value 32	Setting range	Default	Unit	Applicable mode
		-2147483.646–2147483.647	0	-	P S T
This parameter specifies the positioning compensation value 32.					
P5.86	Data size	32bit	Data format	DEC	
	Modbus communication address	2172, 2173	CANopen communication address	0x2556, 0x00	
P5.87	Positioning compensation value 33	Setting range	Default	Unit	Applicable mode
		-2147483.646–2147483.647	0	-	P S T
This parameter specifies the positioning compensation value 33.					
P5.87	Data size	32bit	Data format	DEC	
	Modbus communication address	2174, 2175	CANopen communication address	0x2557, 0x00	
P5.88	Positioning compensation value 34	Setting range	Default	Unit	Applicable mode
		-2147483.646–2147483.647	0	-	P S T
This parameter specifies the positioning compensation value 34.					
P5.88	Data size	32bit	Data format	DEC	
	Modbus communication address	2176, 2177	CANopen communication address	0x2558, 0x00	
P5.89	Positioning compensation value 35	Setting range	Default	Unit	Applicable mode
		-2147483.646–2147483.647	0	-	P S T
This parameter specifies the positioning compensation value 35.					

P5.89	Data size	32bit	Data format	DEC
	Modbus communication address	2178, 2179	CANopen communication address	0x2559, 0x00

P5.90	Positioning compensation value 36	Setting range	Default	Unit	Applicable mode		
		-2147483.646~ 2147483.647	0	-	P	S	T

This parameter specifies the positioning compensation value 36.

P5.90	Data size	32bit	Data format	DEC
	Modbus communication address	2180, 2181	CANopen communication address	0x255A, 0x00

P5.91	Positioning compensation value 37	Setting range	Default	Unit	Applicable mode		
		-2147483.646~ 2147483.647	0	-	P	S	T

This parameter specifies the positioning compensation value 37.

P5.91	Data size	32bit	Data format	DEC
	Modbus communication address	2182, 2183	CANopen communication address	0x255B, 0x00

P5.92	Positioning compensation value 38	Setting range	Default	Unit	Applicable mode		
		-2147483.646~ 2147483.647	0	-	P	S	T

This parameter specifies the positioning compensation value 38.

P5.92	Data size	32bit	Data format	DEC
	Modbus communication address	2184, 2185	CANopen communication address	0x255C, 0x00

P5.93	Positioning compensation value 39	Setting range	Default	Unit	Applicable mode		
		-2147483.646~ 2147483.647	0	-	P	S	T

This parameter specifies the positioning compensation value 39.

P5.93	Data size	32bit	Data format	DEC
	Modbus communication address	2186, 2187	CANopen communication address	0x255D, 0x00

P5.94	Positioning compensation value 40	Setting range	Default	Unit	Applicable mode		
		-2147483.646~2147483.647	0	-	P	S	T

This parameter specifies the positioning compensation value 40.

P5.94	Data size	32bit	Data format	DEC
	Modbus communication address	2188, 2189	CANopen communication address	0x255E, 0x00

P5.95	Positioning compensation value 41	Setting range	Default	Unit	Applicable mode		
		-2147483.646~2147483.647	0	-	P	S	T

This parameter specifies the positioning compensation value 41.

P5.95	Data size	32bit	Data format	DEC
	Modbus communication address	2190, 2191	CANopen communication address	0x255F, 0x00

P5.96	Positioning compensation value 42	Setting range	Default	Unit	Applicable mode		
		-2147483.646~2147483.647	0	-	P	S	T

This parameter specifies the positioning compensation value 42.

P5.96	Data size	32bit	Data format	DEC
	Modbus communication address	2192, 2193	CANopen communication address	0x2560, 0x00

P5.97	Positioning compensation	Setting range	Default	Unit	Applicable mode		
-------	--------------------------	----------------------	----------------	-------------	------------------------	--	--

	value 43	-2147483.646– 2147483.647	0	-	P	S	T
This parameter specifies the positioning compensation value 43.							
P5.97	Data size	32bit	Data format	DEC			
	Modbus communication address	2194, 2195	CANopen communication address	0x2561, 0x00			
P5.98	Positioning compensation value 44	Setting range	Default	Unit	Applicable mode		
		-2147483.646– 2147483.647	0	-	P	S	T
This parameter specifies the positioning compensation value 44.							
P5.98	Data size	32bit	Data format	DEC			
	Modbus communication address	2196, 2197	CANopen communication address	0x2562, 0x00			
P5.99	Positioning compensation value 45	Setting range	Default	Unit	Applicable mode		
		-2147483.646– 2147483.647	0	-	P	S	T
This parameter specifies the positioning compensation value 45.							
P5.99	Data size	32bit	Data format	DEC			
	Modbus communication address	2198, 2199	CANopen communication address	0x2563, 0x00			

9.7 Application functions (Group P6 parameters)

P6.00	Forward low jogging speed	Setting range	Default	Unit	Applicable mode		
		0–6000	5	r/min	P	-	-
This parameter specifies the speed of slow forward jogging, which is triggered by the forward jogging terminal and high-low jogging speed switching terminal.							
P6.00	Data size	16bit	Data format	DEC			
	Modbus communication address	2200, 2201	CANopen communication address	0x2600, 0x00			

P6.01	Reverse low jogging speed	Setting range	Default	Unit	Applicable mode		
		-6000-0	-5	r/min	P	-	-
This parameter specifies the speed of slow reverse jogging, which is triggered by the reverse jogging terminal and high-low jogging speed switching terminal.							
P6.01	Data size	16bit	Data format		DEC		
	Modbus communication address	2202, 2203	CANopen communication address		0x2601, 0x00		
P6.02 ¹	Data latching switch	Setting range	Default	Unit	Applicable mode		
		0-1	0	-	P	-	-
This parameter specifies whether to enable the data latching switch. If the switch is enabled, the position information is written to the EEPROM each time the terminal is latched. However, frequent latching may cause EEPROM damage.							
		Set value	Description				
		[0]	Disable				
		1	Enable				
P6.02 ¹	Data size	16bit	Data format		DEC		
	Modbus communication address	2204, 2205	CANopen communication address		0x2602, 0x00		
P6.03	Position latching save mode	Setting range	Default	Unit	Applicable mode		
		0-1	0	-	P	-	-
This parameter specifies whether to save position latching.							
		Set value	Description				
		[0]	Not save				
		1	Save				
P6.03	Data size	16bit	Data format		DEC		
	Modbus communication address	2206, 2207	CANopen communication address		0x2603, 0x00		
P6.04	Forward high jogging speed	Setting range	Default	Unit	Applicable mode		
		0-6000	60	r/min	P	-	-
This parameter specifies the speed of fast forward jogging, which is triggered by the forward							

jogging terminal and high-low jogging speed switching terminal.

P6.04	Data size	16bit	Data format	DEC
	Modbus communication address	2208, 2209	CANopen communication address	0x2604, 0x00

P6.05	Reverse high jogging speed	Setting range	Default	Unit	Applicable mode		
		-6000~0	-60	r/min	P	-	-

This parameter specifies the speed of fast reverse jogging, which is triggered by the reverse jogging terminal and high-low jogging speed switching terminal.

P6.05	Data size	16bit	Data format	DEC
	Modbus communication address	2210, 2211	CANopen communication address	0x2605, 0x00

P6.06	Enable terminal jogging	Setting range	Default	Unit	Applicable mode		
		0~1	0	-	P	-	-

This parameter specifies whether to set terminal jogging function.

Set value	Description
[0]	Invalid
1	Valid

P6.06	Data size	16bit	Data format	DEC
	Modbus communication address	2212, 2213	CANopen communication address	0x2606, 0x00

P6.20 ¹	Turret function switch	Setting range	Default	Unit	Applicable mode		
		0~1	0	-	P	-	-

This parameter specifies whether to set turret function switch.

Set value	Description
[0]	Disable
1	Enable

P6.20 ¹	Data size	16bit	Data format	DEC
	Modbus communication address	2240, 2241	CANopen communication address	0x2614, 0x00

P6.21	Knives per turret	Setting range	Default	Unit	Applicable mode		
		1-128	16	piece	P	-	-
This parameter specifies the number of knives in a turret.							
P6.21	Data size	16bit	Data format		DEC		
	Modbus communication address	2242, 2243	CANopen communication address		0x2615, 0x00		
P6.22	Pulses per turret rotation	Setting range	Default	Unit	Applicable mode		
		$2-(2^{31}-1)$	10000	reference unit	P	-	-
This parameter specifies the number of pulses needed for each turret rotation.							
P6.22	Data size	32bit	Data format		DEC		
	Modbus communication address	2244, 2245	CANopen communication address		0x2616, 0x00		
P6.23 ¹	Turret starting point	Setting range	Default	Unit	Applicable mode		
		$-(2^{31}-1)-(2^{31}-1)$	0	reference unit	P	-	-
This parameter is used to set the starting point of turret.							
P6.23 ¹	Data size	32bit	Data format		DEC		
	Modbus communication address	2246, 2247	CANopen communication address		0x2617, 0x00		
P6.30 ¹	Gantry synchronization function switch	Setting range	Default	Unit	Applicable mode		
		0-1	0	-	P	-	-
This parameter specifies whether to enable the gantry synchronization function switch.							
		Set value	Description				
		[0]	Disable				
		1	Enable				
P6.30 ¹	Data size	16bit	Data format		DEC		
	Modbus communication address	2260, 2261	CANopen communication address		0x261E, 0x00		

P6.31	Speed control gain for gantry synchronization	Setting range	Default	Unit	Applicable mode		
		0.0–3276.7	0.0	Hz	P	-	-
This parameter specifies the speed control gain for gantry synchronization.							
P6.31	Data size	16bit	Data format	DEC			
	Modbus communication address	2262, 2263	CANopen communication address	0x261F, 0x00			
P6.32	Speed control integral for gantry synchronization	Setting range	Default	Unit	Applicable mode		
		0.1–1000.0	1000.0	ms	P	-	-
This parameter specifies the time constant of the speed control integral for gantry synchronization. Please note that when this parameter is set to 1000, it indicates that the integral function is invalid.							
P6.32	Data size	16bit	Data format	DEC			
	Modbus communication address	2264, 2265	CANopen communication address	0x2620, 0x00			
P6.33	Position control gain for gantry synchronization	Setting range	Default	Unit	Applicable mode		
		0.0–3276.7	1000.0	Hz	P	-	-
This parameter specifies the position control gain for gantry synchronization.							
P6.33	Data size	16bit	Data format	DEC			
	Modbus communication address	2266, 2267	CANopen communication address	0x2621, 0x00			
P6.34	Torque filter for gantry synchronization compensation	Setting range	Default	Unit	Applicable mode		
		0.00–64.00	0.00	ms	P	-	-
This parameter specifies the torque filter time constant for gantry synchronization compensation.							
P6.34	Data size	16bit	Data format	DEC			
	Modbus communication address	2268, 2269	CANopen communication address	0x2622, 0x00			

P6.35	Speed filter for gantry synchronization compensation	Setting range	Default	Unit	Applicable mode		
		0.00–64.00	0.00	ms	P	-	-
This parameter specifies the speed filter time constant for gantry synchronization compensation.							
P6.35	Data size	16bit	Data format		DEC		
	Modbus communication address	2270, 2271	CANopen communication address		0x2623, 0x00		

P6.36	Bandwidth ratio for gantry synchronization control	Setting range	Default	Unit	Applicable mode		
		0.0–1000.0	0.0	%	P	-	-
This parameter specifies the bandwidth ratio for gantry synchronization control. Bandwidth ratio = Servo bandwidth/(Servo bandwidth + Synchronization bandwidth)							
P6.36	Data size	16bit	Data format		DEC		
	Modbus communication address	2272, 2273	CANopen communication address		0x2624, 0x00		

P6.37 ¹	Master/slave selection for gantry synchronization	Setting range	Default	Unit	Applicable mode		
		0–1	0	-	P	-	-
This parameter specifies the master or slave for gantry synchronization.							
		Set value	Description				
		[0]	Slave				
		1	Master				
P6.37 ¹	Data size	16bit	Data format		DEC		
	Modbus communication address	2274, 2275	CANopen communication address		0x2625, 0x00		

P6.38	Retreat distance for gantry synchronization alignment	Setting range	Default	Unit	Applicable mode		
		$-(2^{31}-2)-(2^{31}-2)$	10000	reference unit	P	-	-
This parameter specifies the distance that the servo retreats after contacting the two alignment sensors.							
P6.38	Data size	32bit	Data format		DEC		
	Modbus	2276, 2277	CANopen		0x2626, 0x00		

	communication address		communication address				
P6.39	Retreat speed for gantry synchronization alignment	Setting range	Default	Unit	Applicable mode		
		1-200	60	r/min	P	-	-
This parameter specifies the speed at which the servo retreats after contacting the two alignment sensors.							
P6.39	Data size	16bit	Data format	DEC			
	Modbus communication address	2278, 2279	CANopen communication address	0x2627, 0x00			
P6.40	Approaching speed for gantry synchronization alignment	Setting range	Default	Unit	Applicable mode		
		1-60	5	r/min	P	-	-
This parameter specifies the speed at which the servo approaches the alignment sensors again after contacting the sensors.							
P6.40	Data size	16bit	Data format	DEC			
	Modbus communication address	2280, 2281	CANopen communication address	0x2628, 0x00			
P6.41	Gantry alignment direction	Setting range	Default	Unit	Applicable mode		
		0-1	0	-	P	-	-
This parameter specifies the gantry alignment direction.							
		Set value	Description				
		[0]	Forward				
		1	Reverse				
P6.41	Data size	16bit	Data format	DEC			
	Modbus communication address	2282, 2283	CANopen communication address	0x2629, 0x00			
P6.42	Function switch of the fixed block	Setting range	Default	Unit	Applicable mode		

		0-1	0	-	P	-	-
This parameter specifies the function switch of the fixed block.							
P6.42	Data size	16bit	Data format	DEC			
	Modbus communication address	2284, 2285	CANopen communication address	0x262A, 0x00			
P6.43	Clamping torque of the fixed block	Setting range	Default	Unit	Applicable mode		
		0-150	1.00	Nm	P	-	-
This parameter specifies the clamping torque of the fixed block.							
P6.43	Data size	32bit	Data format	DEC			
	Modbus communication address	2286, 2287	CANopen communication address	0x262B, 0x00			
P6.44	Max. follow-up error of the fixed block	Setting range	Default	Unit	Applicable mode		
		0-2147483647	1000	pulse	P	-	-
This parameter specifies the Max. follow-up error of the fixed block.							
P6.44	Data size	32bit	Data format	DEC			
	Modbus communication address	2288, 2289	CANopen communication address	0x262C, 0x00			
P6.45	Monitoring window of the fixed block	Setting range	Default	Unit	Applicable mode		
		0-2147483647	100	pulse	P	-	-
This parameter specifies the monitoring window of the fixed block.							
P6.45	Data size	32bit	Data format	DEC			
	Modbus communication address	2290, 2291	CANopen communication address	0x262D, 0x00			
P6.50*	Magnetic pole detection startup command	Setting range	Default	Unit	Applicable mode		
		0-1	0	-	P	S	T
This parameter is used to enable the magnetic pole detection. Corresponding encoders without Hall sensor can determine the electrical angle with this function.							

P6.50*	Data size	16bit	Data format	DEC
	Modbus communication address	2300, 2301	CANopen communication address	0x2632, 0x00

P6.51	Magnetic pole detection speed gain	Setting range	Default	Unit	Applicable mode		
		1-2000	40	Hz	P	S	T

This parameter specifies the magnetic pole detection speed gain.

P6.51	Data size	16bit	Data format	DEC
	Modbus communication address	2302, 2303	CANopen communication address	0x2633, 0x00

P6.52	Speed integral time constant of magnetic pole detection	Setting range	Default	Unit	Applicable mode		
		0.15-512	30	ms	P	S	T

This parameter specifies the speed integral time constant of magnetic pole detection.

P6.52	Data size	16bit	Data format	DEC
	Modbus communication address	2304, 2305	CANopen communication address	0x2634, 0x00

P6.53	Magnetic pole detection inertia ratio	Setting range	Default	Unit	Applicable mode		
		0-20000	100	%	P	S	T

This parameter specifies the magnetic pole detection inertia ratio.

P6.53	Data size	16bit	Data format	DEC
	Modbus communication address	2306, 2307	CANopen communication address	0x2635, 0x00

P6.54	Rotary speed command of magnetic pole detection	Setting range	Default	Unit	Applicable mode		
		0-1000	50	mm/s	P	S	T

This parameter specifies the rotary speed command of magnetic pole detection.

P6.54	Data size	16bit	Data format	DEC
-------	-----------	-------	-------------	-----

	Modbus communication address	2308, 2309	CANopen communication address	0x2636, 0x00			
P6.55	Linear speed command of magnetic pole detection	Setting range	Default	Unit	Applicable mode		
		0–100	20	mm/s	P	S	T
This parameter specifies the linear speed command of magnetic pole detection.							
P6.55	Data size	16bit	Data format	DEC			
	Modbus communication address	2310, 2311	CANopen communication address	0x2637, 0x00			
P6.56	ACC/DEC time of magnetic pole detection speed command	Setting range	Default	Unit	Applicable mode		
		0–100	25	ms	P	S	T
This parameter specifies the ACC/DEC time of magnetic pole detection speed command.							
P6.56	Data size	16bit	Data format	DEC			
	Modbus communication address	2312, 2313	CANopen communication address	0x2638, 0x00			
P6.57	Constant speed time of magnetic pole detection speed command	Setting range	Default	Unit	Applicable mode		
		0–300	0	ms	P	S	T
This parameter specifies the constant speed time of magnetic pole detection speed command.							
P6.57	Data size	16bit	Data format	DEC			
	Modbus communication address	2314, 2315	CANopen communication address	0x2639, 0x00			
P6.58	Wait time of magnetic pole detection speed command	Setting range	Default	Unit	Applicable mode		
		50–500	100	ms	P	S	T

This parameter specifies the wait time of magnetic pole detection speed command.

P6.58	Data size	16bit	Data format	DEC
	Modbus communication address	2316, 2317	CANopen communication address	0x263A, 0x00

P6.59	Repeat times of magnetic pole detection	Setting range	Default	Unit	Applicable mode		
		0-10	4	-	P	S	T

This parameter specifies the repeat times of magnetic pole detection.

P6.59	Data size	16bit	Data format	DEC
	Modbus communication address	2318, 2319	CANopen communication address	0x263B, 0x00

P6.60	Rotary movable range of magnetic pole detection	Setting range	Default	Unit	Applicable mode		
		0.001-32.767	0.250	rev	P	S	T

This parameter specifies the rotary movable range of magnetic pole detection.

P6.60	Data size	16bit	Data format	DEC
	Modbus communication address	2320, 2321	CANopen communication address	0x263C, 0x00

P6.61	Linear movable range of magnetic pole detection	Setting range	Default	Unit	Applicable mode		
		1-32767	10	mm	P	S	T

This parameter specifies the linear movable range of magnetic pole detection.

P6.61	Data size	16bit	Data format	DEC
	Modbus communication address	2322, 2323	CANopen communication address	0x263D, 0x00

P6.62	Gain without integral for pole detection	Setting range	Default	Unit	Applicable mode		
		0-100	0.3	%	P	S	T

This parameter specifies the gain without integral for pole detection.

P6.62	Data size	16bit	Data format	DEC
	Modbus communication address	2324, 2325	CANopen communication address	0x263E, 0x00

P6.63	Starting time without integral for pole detection	Setting range	Default	Unit	Applicable mode		
		0-100	30	%	P	S	T
This parameter specifies the starting time without integral for pole detection.							
P6.63	Data size	16bit	Data format		DEC		
	Modbus communication address	2326, 2327	CANopen communication address		0x263F, 0x00		
P6.64	Torque in checking process for pole detection	Setting range	Default	Unit	Applicable mode		
		0-200	100	%	P	S	T
This parameter specifies the torque in checking process for pole detection.							
P6.64	Data size	16bit	Data format		DEC		
	Modbus communication address	2328, 2329	CANopen communication address		0x2640, 0x00		
P6.65	ACC/DEC time of torque in checking process for pole detection	Setting range	Default	Unit	Applicable mode		
		0-1000	10	ms	P	S	T
This parameter specifies the ACC/DEC time of torque in checking process for pole detection.							
P6.65	Data size	16bit	Data format		DEC		
	Modbus communication address	2330, 2331	CANopen communication address		0x2641, 0x00		
P6.66	Constant time of torque in checking process for pole detection	Setting range	Default	Unit	Applicable mode		
		0-3000	1500	ms	P	S	T
This parameter specifies the constant time of torque in checking process for pole detection.							
P6.66	Data size	16bit	Data format		DEC		
	Modbus communication address	2332, 2333	CANopen communication address		0x2642, 0x00		
P6.67	Allowable error range of magnetic	Setting range	Default	Unit	Applicable mode		

	pole detection	0-30	10	deg	P	S	T
This parameter specifies the allowable error range of magnetic pole detection.							
35P6.67	Data size	16bit	Data format		DEC		
	Modbus communication address	2334, 2335	CANopen communication address		0x2643, 0x00		
P6.68	Retrograde threshold in magnetic pole detection operation	Setting range	Default	Unit	Applicable mode		
		0-100	15	%	P	S	T
This parameter specifies the retrograde threshold in magnetic pole detection operation.							
P6.68	Data size	16bit	Data format		DEC		
	Modbus communication address	2336, 2337	CANopen communication address		0x2644, 0x00		
P6.69	Retrograde threshold in magnetic pole detection waiting	Setting range	Default	Unit	Applicable mode		
		0-100	50	%	P	S	T
This parameter specifies the retrograde threshold in magnetic pole detection waiting.							
P6.69	Data size	16bit	Data format		DEC		
	Modbus communication address	2338, 2339	CANopen communication address		0x2645, 0x00		
P6.70	Magnetic pole detection overspeed threshold	Setting range	Default	Unit	Applicable mode		
		100-500	180	%	P	S	T
This parameter specifies the magnetic pole detection overspeed threshold.							
P6.70	Data size	16bit	Data format		DEC		
	Modbus communication address	2340, 2341	CANopen communication address		0x2646, 0x00		
P6.71	Positioning compensation enabling	Setting range	Default	Unit	Applicable mode		
		0-1	0	-	P	S	T

This parameter specifies the positioning compensation enabling.

P6.71	Data size	16bit	Data format	DEC
	Modbus communication address	2342, 2343	CANopen communication address	0x2647, 0x00

P6.72	Positioning compensation unit	Setting range	Default	Unit	Applicable mode		
		0-6	0	-	P	S	T

This parameter specifies the positioning compensation unit.

P6.72	Data size	16bit	Data format	DEC
	Modbus communication address	2344, 2345	CANopen communication address	0x2648, 0x00

P6.73	Starting position of positioning compensation	Setting range	Default	Unit	Applicable mode		
		-2147483646-2147483647	0	-	P	S	T

This parameter specifies the starting position of positioning compensation.

P6.73	Data size	32bit	Data format	DEC
	Modbus communication address	2346, 2347	CANopen communication address	0x2649, 0x00

P6.74	Points of position compensation	Setting range	Default	Unit	Applicable mode		
		0-1000	100	-	P	S	T

This parameter specifies the points of position compensation.

P6.74	Data size	16bit	Data format	DEC
	Modbus communication address	2348, 2349	CANopen communication address	0x264A, 0x00

P6.75	Starting index bias of positioning compensation	Setting range	Default	Unit	Applicable mode		
		0-1000	0	-	P	S	T

This parameter specifies the starting index bias of positioning compensation.

P6.75	Data size	16bit	Data format	DEC
-------	-----------	-------	-------------	-----

	Modbus communication address	2350, 2351	CANopen communication address	0x264B, 0x00
--	------------------------------	------------	-------------------------------	--------------

P6.76	Positioning compensation distance	Setting range	Default	Unit	Applicable mode		
		0-100000	100	-	P	S	T

This parameter specifies the positioning compensation distance.

P6.76	Data size	32bit	Data format	DEC		
	Modbus communication address	2352, 2353	CANopen communication address	0x264C, 0x00		

P6.77	Gear ratio numerator of positioning compensation	Setting range	Default	Unit	Applicable mode		
		-2147483646-2147483647	1	-	P	S	T

This parameter specifies the gear ratio numerator of positioning compensation.

P6.77	Data size	32bit	Data format	DEC		
	Modbus communication address	2354, 2355	CANopen communication address	0x264D, 0x00		

P6.78	Gear ratio denominator of positioning compensation	Setting range	Default	Unit	Applicable mode		
		1-2147483647	1	-	P	S	T

This parameter specifies the gear ratio denominator of positioning compensation.

P6.78	Data size	32bit	Data format	DEC		
	Modbus communication address	2356, 2357	CANopen communication address	0x264E, 0x00		

P6.79	Positioning compensation value 1	Setting range	Default	Unit	Applicable mode		
		-2147483.646-2147483.647	0	-	P	S	T

This parameter specifies the positioning compensation value 1.						
P6.79	Data size	32bit	Data format	DEC		
	Modbus communication address	2358, 2359	CANopen communication address	0x264F, 0x00		
P6.80	Positioning compensation value 2	Setting range	Default	Unit	Applicable mode	
		-2147483.646~2147483.647	0	-	P	S
This parameter specifies the positioning compensation value 2.						
P6.80	Data size	32bit	Data format	DEC		
	Modbus communication address	2360, 2361	CANopen communication address	0x2650, 0x00		
P6.81	Positioning compensation value 3	Setting range	Default	Unit	Applicable mode	
		-2147483.646~2147483.647	0	-	P	S
This parameter specifies the positioning compensation value 3.						
P6.81	Data size	32bit	Data format	DEC		
	Modbus communication address	2362, 2363	CANopen communication address	0x2651, 0x00		
P6.82	Positioning compensation value 4	Setting range	Default	Unit	Applicable mode	
		-2147483.646~2147483.647	0	-	P	S
This parameter specifies the positioning compensation value 4.						
P6.82	Data size	32bit	Data format	DEC		
	Modbus communication address	2364, 2365	CANopen communication address	0x2652, 0x00		
P6.83	Positioning compensation value 5	Setting range	Default	Unit	Applicable mode	
		-2147483.646~2147483.647	0	-	P	S

This parameter specifies the positioning compensation value 5.				
P6.83	Data size	32bit	Data format	DEC
	Modbus communication address	2366, 2367	CANopen communication address	0x2653, 0x00

P6.84	Positioning compensation value 6	Setting range	Default	Unit	Applicable mode		
		-2147483.646~2147483.647	0	-	P	S	T

This parameter specifies the positioning compensation value 6.				
P6.84	Data size	32bit	Data format	DEC
	Modbus communication address	2368, 2369	CANopen communication address	0x2654, 0x00

P6.85	Positioning compensation value 7	Setting range	Default	Unit	Applicable mode		
		-2147483.646~2147483.647	0	-	P	S	T

This parameter specifies the positioning compensation value 7.				
P6.85	Data size	32bit	Data format	DEC
	Modbus communication address	2370, 2371	CANopen communication address	0x2655, 0x00

P6.86	Positioning compensation value 8	Setting range	Default	Unit	Applicable mode		
		-2147483.646~2147483.647	0	-	P	S	T

This parameter specifies the positioning compensation value 8.				
P6.86	Data size	32bit	Data format	DEC
	Modbus communication address	2372, 2373	CANopen communication address	0x2656, 0x00

P6.87	Positioning compensation	Setting range	Default	Unit	Applicable mode		
-------	--------------------------	----------------------	----------------	-------------	------------------------	--	--

	value 9	-2147483.646- 2147483.647	0	-	P	S	T
This parameter specifies the positioning compensation value 9.							
P6.87	Data size	32bit	Data format	DEC			
	Modbus communication address	2374, 2375	CANopen communication address	0x2657, 0x00			
P6.88	Positioning compensation value 10	Setting range	Default	Unit	Applicable mode		
		-2147483.646- 2147483.647	0	-	P	S	T
This parameter specifies the positioning compensation value 10.							
P6.88	Data size	32bit	Data format	DEC			
	Modbus communication address	2376, 2377	CANopen communication address	0x2658, 0x00			
P6.89	Positioning compensation value 11	Setting range	Default	Unit	Applicable mode		
		-2147483.646- 2147483.647	0	-	P	S	T
This parameter specifies the positioning compensation value 11.							
P6.89	Data size	32bit	Data format	DEC			
	Modbus communication address	2378, 2379	CANopen communication address	0x2659, 0x00			
P6.90	Positioning compensation value 12	Setting range	Default	Unit	Applicable mode		
		-2147483.646- 2147483.647	0	-	P	S	T
This parameter specifies the positioning compensation value 12.							
P6.90	Data size	32bit	Data format	DEC			
	Modbus communication address	2380, 2381	CANopen communication address	0x265A, 0x00			

P6.91	Positioning compensation value 13	Setting range	Default	Unit	Applicable mode		
		-2147483.646~2147483.647	0	-	P	S	T
This parameter specifies the positioning compensation value 13.							
P6.91	Data size	32bit	Data format	DEC			
	Modbus communication address	2382, 2383	CANopen communication address	0x265B, 0x00			
P6.92	Positioning compensation value 14	Setting range	Default	Unit	Applicable mode		
		-2147483.646~2147483.647	0	-	P	S	T
This parameter specifies the positioning compensation value 14.							
P6.92	Data size	32bit	Data format	DEC			
	Modbus communication address	2384, 2385	CANopen communication address	0x265C, 0x00			
P6.93	Positioning compensation value 15	Setting range	Default	Unit	Applicable mode		
		-2147483.646~2147483.647	0	-	P	S	T
This parameter specifies the positioning compensation value 15.							
P6.93	Data size	32bit	Data format	DEC			
	Modbus communication address	2386, 2387	CANopen communication address	0x265D, 0x00			
P6.94	Positioning compensation value 16	Setting range	Default	Unit	Applicable mode		
		-2147483.646~2147483.647	0	-	P	S	T
This parameter specifies the positioning compensation value 16.							
P6.94	Data size	32bit	Data format	DEC			
	Modbus	2388, 2389	CANopen	0x265E, 0x00			

	communication address		communication address	
--	-----------------------	--	-----------------------	--

P6.95	Positioning compensation value 17	Setting range	Default	Unit	Applicable mode		
		-2147483.646~2147483.647	0	-	P	S	T

This parameter specifies the positioning compensation value 17.

P6.95	Data size	32bit	Data format	DEC
	Modbus communication address	2390, 2391	CANopen communication address	0x265F, 0x00

P6.96	Positioning compensation value 18	Setting range	Default	Unit	Applicable mode		
		-2147483.646~2147483.647	0	-	P	S	T

This parameter specifies the positioning compensation value 18.

P6.96	Data size	32bit	Data format	DEC
	Modbus communication address	2392, 2393	CANopen communication address	0x2660, 0x00

P6.97	Positioning compensation value 19	Setting range	Default	Unit	Applicable mode		
		-2147483.646~2147483.647	0	-	P	S	T

This parameter specifies the positioning compensation value 19.

P6.97	Data size	32bit	Data format	DEC
	Modbus communication address	2394, 2395	CANopen communication address	0x2661, 0x00

P6.98	Positioning compensation value 20	Setting range	Default	Unit	Applicable mode		
		-2147483.646~2147483.647	0	-	P	S	T

This parameter specifies the positioning compensation value 20.

P6.98	Data size	32bit	Data format	DEC
	Modbus communication address	2396, 2397	CANopen communication address	0x2662, 0x00

P6.99	Positioning compensation value 21	Setting range	Default	Unit	Applicable mode		
		-2147483.646–2147483.647	0	-	P	S	T

This parameter specifies the positioning compensation value 21.

P6.99	Data size	32bit	Data format	DEC
	Modbus communication address	2398, 2399	CANopen communication address	0x2663, 0x00

9.8 PTP control (Group PtP0, PtP1 and PtP2 parameters)

PtP0.00	Control word of segment 00	Setting range	Default	Unit	Applicable mode		
		0–0x7FFFFFFF	0x00000000	-	P		

General description:

Data bit	Symbol	Function
Bit0–bit3	MODE	PTP running mode.
Bit4–bit7	OPT	PTP attribute.
Bit8–bit11	ACC	ACC/DEC time index
Bit12–bit15	SPD	Target speed index
Bit16–bit19	DLY	Delay time index
Bit20–bit23	CYL	Number of cycles for executing the current segment
Bit24–bit30	JMP	The program jumps to the next segment.

Description for MODE:

MODE	Description
0	The program stops after the current segment is executed.
1	The program jumps to the next segment after the current segment is executed.
2	The program stops after circular execution. If CMD is 1, the circulation is invalid.

3	The program jumps to the next segment after circular execution. If CMD is 1, the circulation is invalid.
---	--

Description for OPT:

Data bit	Symbol	Function
Bit4	INS	Insertion. The current segment can suspend segments that are being executed or not executed.
Bit5	OVL P	Overlap. The current segment and next segment can overlap and then be executed.
Bit6-bit7	CMD	Position command type: 0 indicates incremental position while 1 indicates absolute position.

Description for INS

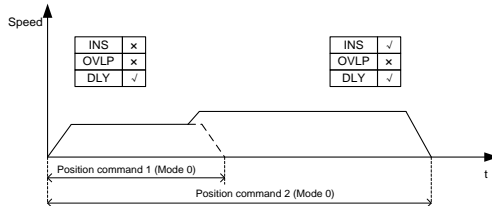
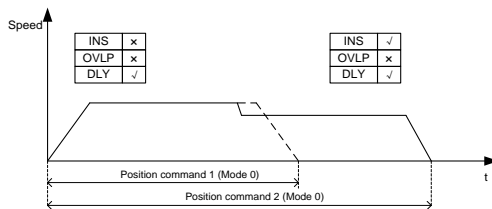

Description for OVL P

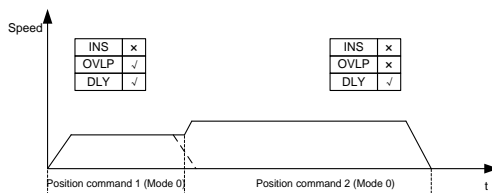
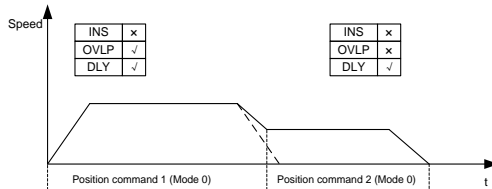

Relationship between INS and OVLP

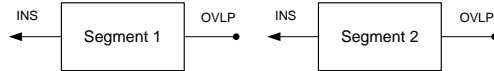

Note:

- INS indicates the current segment has execution priority over the previous one, while OVLP indicates the current segment is executed after the overlap with the next one is checked.
- INS takes priority over OVLP. For example, if both OVLP for segment 1 and INS for segment 2 are enabled, OVLP for segment 1 is invalid.
- The two segments in the reverse directions cannot overlap.

PtP0.00	Data size	32bit	Data format	HEX
	Modbus communication address	3200, 3201	CANopen communication address	0x2B00, 0x00

PtP0.01	Position of segment 00	Setting range	Default	Unit	Applicable mode		
		$-(2^{31}-1)-(2^{31}-1)$	0	reference unit	P	-	-

This parameter specifies the position of segment 00. The CMD attribute determines the command mode of this PTP position. P0.37 is inapplicable to this PTP position.

PtP0.01	Data size	32bit	Data format	DEC
	Modbus communication address	3202, 3203	CANopen communication address	0x2B01, 0x00

PtP0.02	Control word of segment 01	Setting range	Default	Unit	Applicable mode		
		0-0x7FFFFFFF	0x00000000	-	P	-	-
PtP0.04	Control word of segment 02	Setting range	Default	Unit	Applicable mode		
		0-0x7FFFFFFF	0x00000000	-	P	-	-
PtP0.06	Control word of segment 03	Setting range	Default	Unit	Applicable mode		
		0-0x7FFFFFFF	0x00000000	-	P	-	-
PtP0.08	Control word of segment 04	Setting range	Default	Unit	Applicable mode		
		0-0x7FFFFFFF	0x00000000	-	P	-	-
PtP0.10	Control word of segment 05	Setting range	Default	Unit	Applicable mode		

		0-0x7FFFFFFF	0x00000000	-	P	-	-
PtP0.12	Control word of segment 06	Setting range	Default	Unit	Applicable mode		
		0-0x7FFFFFFF	0x00000000	-	P	-	-
PtP0.14	Control word of segment 07	Setting range	Default	Unit	Applicable mode		
		0-0x7FFFFFFF	0x00000000	-	P	-	-
PtP0.16	Control word of segment 08	Setting range	Default	Unit	Applicable mode		
		0-0x7FFFFFFF	0x00000000	-	P	-	-
PtP0.18	Control word of segment 09	Setting range	Default	Unit	Applicable mode		
		0-0x7FFFFFFF	0x00000000	-	P	-	-
PtP0.20	Control word of segment 10	Setting range	Default	Unit	Applicable mode		
		0-0x7FFFFFFF	0x00000000	-	P	-	-
PtP0.22	Control word of segment 11	Setting range	Default	Unit	Applicable mode		
		0-0x7FFFFFFF	0x00000000	-	P	-	-
PtP0.24	Control word of segment 12	Setting range	Default	Unit	Applicable mode		
		0-0x7FFFFFFF	0x00000000	-	P	-	-
PtP0.26	Control word of segment 13	Setting range	Default	Unit	Applicable mode		
		0-0x7FFFFFFF	0x00000000	-	P	-	-
PtP0.28	Control word of segment 14	Setting range	Default	Unit	Applicable mode		
		0-0x7FFFFFFF	0x00000000	-	P	-	-
PtP0.30	Control word of segment 15	Setting range	Default	Unit	Applicable mode		
		0-0x7FFFFFFF	0x00000000	-	P	-	-
PtP0.32	Control word of segment 16	Setting range	Default	Unit	Applicable mode		
		0-0x7FFFFFFF	0x00000000	-	P	-	-
PtP0.34	Control word of segment 17	Setting range	Default	Unit	Applicable mode		
		0-0x7FFFFFFF	0x00000000	-	P	-	-
PtP0.36	Control word of segment 18	Setting range	Default	Unit	Applicable mode		

		0-0x7FFFFFFF	0x00000000	-	P	-	-
PtP0.38	Control word of segment 19	Setting range	Default	Unit	Applicable mode		
		0-0x7FFFFFFF	0x00000000	-	P	-	-
PtP0.40	Control word of segment 20	Setting range	Default	Unit	Applicable mode		
		0-0x7FFFFFFF	0x00000000	-	P	-	-
PtP0.42	Control word of segment 21	Setting range	Default	Unit	Applicable mode		
		0-0x7FFFFFFF	0x00000000	-	P	-	-
PtP0.44	Control word of segment 22	Setting range	Default	Unit	Applicable mode		
		0-0x7FFFFFFF	0x00000000	-	P	-	-
PtP0.46	Control word of segment 23	Setting range	Default	Unit	Applicable mode		
		0-0x7FFFFFFF	0x00000000	-	P	-	-
PtP0.48	Control word of segment 24	Setting range	Default	Unit	Applicable mode		
		0-0x7FFFFFFF	0x00000000	-	P	-	-
PtP0.50	Control word of segment 25	Setting range	Default	Unit	Applicable mode		
		0-0x7FFFFFFF	0x00000000	-	P	-	-
PtP0.52	Control word of segment 26	Setting range	Default	Unit	Applicable mode		
		0-0x7FFFFFFF	0x00000000	-	P	-	-
PtP0.54	Control word of segment 27	Setting range	Default	Unit	Applicable mode		
		0-0x7FFFFFFF	0x00000000	-	P	-	-
PtP0.56	Control word of segment 28	Setting range	Default	Unit	Applicable mode		
		0-0x7FFFFFFF	0x00000000	-	P	-	-
PtP0.58	Control word of segment 29	Setting range	Default	Unit	Applicable mode		
		0-0x7FFFFFFF	0x00000000	-	P	-	-
PtP0.60	Control word of segment 30	Setting range	Default	Unit	Applicable mode		
		0-0x7FFFFFFF	0x00000000	-	P	-	-
PtP0.62	Control word of segment 31	Setting range	Default	Unit	Applicable mode		

		0-0x7FFFFFFF	0x00000000	-	P	-	-
PtP0.64	Control word of segment 32	Setting range	Default	Unit	Applicable mode		
		0-0x7FFFFFFF	0x00000000	-	P	-	-
PtP0.66	Control word of segment 33	Setting range	Default	Unit	Applicable mode		
		0-0x7FFFFFFF	0x00000000	-	P	-	-
PtP0.68	Control word of segment 34	Setting range	Default	Unit	Applicable mode		
		0-0x7FFFFFFF	0x00000000	-	P	-	-
PtP0.70	Control word of segment 35	Setting range	Default	Unit	Applicable mode		
		0-0x7FFFFFFF	0x00000000	-	P	-	-
PtP0.72	Control word of segment 36	Setting range	Default	Unit	Applicable mode		
		0-0x7FFFFFFF	0x00000000	-	P	-	-
PtP0.74	Control word of segment 37	Setting range	Default	Unit	Applicable mode		
		0-0x7FFFFFFF	0x00000000	-	P	-	-
PtP0.76	Control word of segment 38	Setting range	Default	Unit	Applicable mode		
		0-0x7FFFFFFF	0x00000000	-	P	-	-
PtP0.78	Control word of segment 39	Setting range	Default	Unit	Applicable mode		
		0-0x7FFFFFFF	0x00000000	-	P	-	-
PtP0.80	Control word of segment 40	Setting range	Default	Unit	Applicable mode		
		0-0x7FFFFFFF	0x00000000	-	P	-	-
PtP0.82	Control word of segment 41	Setting range	Default	Unit	Applicable mode		
		0-0x7FFFFFFF	0x00000000	-	P	-	-
PtP0.84	Control word of segment 42	Setting range	Default	Unit	Applicable mode		
		0-0x7FFFFFFF	0x00000000	-	P	-	-
PtP0.86	Control word of segment 43	Setting range	Default	Unit	Applicable mode		
		0-0x7FFFFFFF	0x00000000	-	P	-	-
PtP0.88	Control word of segment 44	Setting range	Default	Unit	Applicable mode		

		0-0x7FFFFFFF	0x00000000	-	P	-	-
PtP0.90	Control word of segment 45	Setting range	Default	Unit	Applicable mode		
		0-0x7FFFFFFF	0x00000000	-	P	-	-
PtP0.92	Control word of segment 46	Setting range	Default	Unit	Applicable mode		
		0-0x7FFFFFFF	0x00000000	-	P	-	-
PtP0.94	Control word of segment 47	Setting range	Default	Unit	Applicable mode		
		0-0x7FFFFFFF	0x00000000	-	P	-	-
PtP0.96	Control word of segment 48	Setting range	Default	Unit	Applicable mode		
		0-0x7FFFFFFF	0x00000000	-	P	-	-
PtP0.98	Control word of segment 49	Setting range	Default	Unit	Applicable mode		
		0-0x7FFFFFFF	0x00000000	-	P	-	-

This group of parameters specify the control words of segment 01 to segment 49. For details, see the description for PtP0.00.

PtP0.02	Data size	32bit	Data format	HEX
	Modbus communication address	3204, 3205	CANopen communication address	0x2B02, 0x00
PtP0.04	Data size	32bit	Data format	HEX
	Modbus communication address	3208, 3209	CANopen communication address	0x2B04, 0x00
PtP0.06	Data size	32bit	Data format	HEX
	Modbus communication address	3212, 3213	CANopen communication address	0x2B06, 0x00
PtP0.08	Data size	32bit	Data format	HEX
	Modbus communication address	3216, 3217	CANopen communication address	0x2B08, 0x00
PtP0.10	Data size	32bit	Data format	HEX
	Modbus communication address	3220, 3221	CANopen communication address	0x2B0A, 0x00
PtP0.12	Data size	32bit	Data format	HEX

	Modbus communication address	3224, 3225	CANopen communication address	0x2B0C, 0x00
PtP0.14	Data size	32bit	Data format	HEX
	Modbus communication address	3228, 3229	CANopen communication address	0x2B0E, 0x00
PtP0.16	Data size	32bit	Data format	HEX
	Modbus communication address	3232, 3233	CANopen communication address	0x2B10, 0x00
PtP0.18	Data size	32bit	Data format	HEX
	Modbus communication address	3236, 3237	CANopen communication address	0x2B12, 0x00
PtP0.20	Data size	32bit	Data format	HEX
	Modbus communication address	3240, 3241	CANopen communication address	0x2B14, 0x00
PtP0.22	Data size	32bit	Data format	HEX
	Modbus communication address	3244, 3245	CANopen communication address	0x2B16, 0x00
PtP0.24	Data size	32bit	Data format	HEX
	Modbus communication address	3248, 3249	CANopen communication address	0x2B18, 0x00
PtP0.26	Data size	32bit	Data format	HEX
	Modbus communication address	3252, 3253	CANopen communication address	0x2B1A, 0x00
PtP0.28	Data size	32bit	Data format	HEX
	Modbus communication address	3256, 3257	CANopen communication address	0x2B1C, 0x00
PtP0.30	Data size	32bit	Data format	HEX
	Modbus communication address	3260, 3261	CANopen communication address	0x2B1E, 0x00

PtP0.32	Data size	32bit	Data format	HEX
	Modbus communication address	3264, 3265	CANopen communication address	0x2B20, 0x00
PtP0.34	Data size	32bit	Data format	HEX
	Modbus communication address	3268, 3269	CANopen communication address	0x2B22, 0x00
PtP0.36	Data size	32bit	Data format	HEX
	Modbus communication address	3272, 3273	CANopen communication address	0x2B24, 0x00
PtP0.38	Data size	32bit	Data format	HEX
	Modbus communication address	3276, 3277	CANopen communication address	0x2B26, 0x00
PtP0.40	Data size	32bit	Data format	HEX
	Modbus communication address	3280, 3281	CANopen communication address	0x2B28, 0x00
PtP0.42	Data size	32bit	Data format	HEX
	Modbus communication address	3284, 3285	CANopen communication address	0x2B2A, 0x00
PtP0.44	Data size	32bit	Data format	HEX
	Modbus communication address	3288, 3289	CANopen communication address	0x2B2C, 0x00
PtP0.46	Data size	32bit	Data format	HEX
	Modbus communication address	3292, 3293	CANopen communication address	0x2B2E, 0x00
PtP0.48	Data size	32bit	Data format	HEX
	Modbus communication address	3296, 3297	CANopen communication address	0x2B30, 0x00
PtP0.50	Data size	32bit	Data format	HEX
	Modbus communication	3300, 3301	CANopen communication	0x2B32, 0x00

	address		address	
PtP0.52	Data size	32bit	Data format	HEX
	Modbus communication address	3304, 3305	CANopen communication address	0x2B34, 0x00
PtP0.54	Data size	32bit	Data format	HEX
	Modbus communication address	3308, 3309	CANopen communication address	0x2B36, 0x00
PtP0.56	Data size	32bit	Data format	HEX
	Modbus communication address	3312, 3313	CANopen communication address	0x2B38, 0x00
PtP0.58	Data size	32bit	Data format	HEX
	Modbus communication address	3316, 3317	CANopen communication address	0x2B3A, 0x00
PtP0.60	Data size	32bit	Data format	HEX
	Modbus communication address	3320, 3321	CANopen communication address	0x2B3C, 0x00
PtP0.62	Data size	32bit	Data format	HEX
	Modbus communication address	3324, 3325	CANopen communication address	0x2B3E, 0x00
PtP0.64	Data size	32bit	Data format	HEX
	Modbus communication address	3328, 3329	CANopen communication address	0x2B40, 0x00
PtP0.66	Data size	32bit	Data format	HEX
	Modbus communication address	3332, 3333	CANopen communication address	0x2B42, 0x00
PtP0.68	Data size	32bit	Data format	HEX
	Modbus communication address	3336, 3337	CANopen communication address	0x2B44, 0x00
PtP0.70	Data size	32bit	Data format	HEX
	Modbus	3340, 3341	CANopen	0x2B46, 0x00

	communication address		communication address	
PtP0.72	Data size	32bit	Data format	HEX
	Modbus communication address	3344, 3345	CANopen communication address	0x2B48, 0x00
PtP0.74	Data size	32bit	Data format	HEX
	Modbus communication address	3348, 3349	CANopen communication address	0x2B4A, 0x00
PtP0.76	Data size	32bit	Data format	HEX
	Modbus communication address	3352, 3353	CANopen communication address	0x2B4C, 0x00
PtP0.78	Data size	32bit	Data format	HEX
	Modbus communication address	3356, 3357	CANopen communication address	0x2B4E, 0x00
PtP0.80	Data size	32bit	Data format	HEX
	Modbus communication address	3360, 3361	CANopen communication address	0x2B50, 0x00
PtP0.82	Data size	32bit	Data format	HEX
	Modbus communication address	3364, 3365	CANopen communication address	0x2B52, 0x00
PtP0.84	Data size	32bit	Data format	HEX
	Modbus communication address	3368, 3369	CANopen communication address	0x2B54, 0x00
PtP0.86	Data size	32bit	Data format	HEX
	Modbus communication address	3372, 3373	CANopen communication address	0x2B56, 0x00
PtP0.88	Data size	32bit	Data format	HEX
	Modbus communication address	3376, 3377	CANopen communication address	0x2B58, 0x00
PtP0.90	Data size	32bit	Data format	HEX

	Modbus communication address	3380, 3381	CANopen communication address	0x2B5A, 0x00
PtP0.92	Data size	32bit	Data format	HEX
	Modbus communication address	3384, 3385	CANopen communication address	0x2B5C, 0x00
PtP0.94	Data size	32bit	Data format	HEX
	Modbus communication address	3388, 3389	CANopen communication address	0x2B5E, 0x00
PtP0.96	Data size	32bit	Data format	HEX
	Modbus communication address	3392, 3393	CANopen communication address	0x2B60, 0x00
PtP0.98	Data size	32bit	Data format	HEX
	Modbus communication address	3396, 3397	CANopen communication address	0x2B62, 0x00

PtP0.03	Position of segment 01	Setting range	Default	Unit	Applicable mode		
		$-(2^{31}-1)-(2^{31}-1)$	0	reference unit	P	-	-
PtP0.05	Position of segment 02	Setting range	Default	Unit	Applicable mode		
		$-(2^{31}-1)-(2^{31}-1)$	0	reference unit	P	-	-
PtP0.07	Position of segment 03	Setting range	Default	Unit	Applicable mode		
		$-(2^{31}-1)-(2^{31}-1)$	0	reference unit	P	-	-
PtP0.09	Position of segment 04	Setting range	Default	Unit	Applicable mode		
		$-(2^{31}-1)-(2^{31}-1)$	0	reference unit	P	-	-
PtP0.11	Position of segment 05	Setting range	Default	Unit	Applicable mode		
		$-(2^{31}-1)-(2^{31}-1)$	0	reference unit	P	-	-
PtP0.13	Position of segment 06	Setting range	Default	Unit	Applicable mode		
		$-(2^{31}-1)-(2^{31}-1)$	0	reference unit	P	-	-

PtP0.15	Position of segment 07	Setting range	Default	Unit	Applicable mode		
		$-(2^{31}-1)-(2^{31}-1)$	0	reference unit	P	-	-
PtP0.17	Position of segment 08	Setting range	Default	Unit	Applicable mode		
		$-(2^{31}-1)-(2^{31}-1)$	0	reference unit	P	-	-
PtP0.19	Position of segment 09	Setting range	Default	Unit	Applicable mode		
		$-(2^{31}-1)-(2^{31}-1)$	0	reference unit	P	-	-
PtP0.21	Position of segment 10	Setting range	Default	Unit	Applicable mode		
		$-(2^{31}-1)-(2^{31}-1)$	0	reference unit	P	-	-
PtP0.23	Position of segment 11	Setting range	Default	Unit	Applicable mode		
		$-(2^{31}-1)-(2^{31}-1)$	0	reference unit	P	-	-
PtP0.25	Position of segment 12	Setting range	Default	Unit	Applicable mode		
		$-(2^{31}-1)-(2^{31}-1)$	0	reference unit	P	-	-
PtP0.27	Position of segment 13	Setting range	Default	Unit	Applicable mode		
		$-(2^{31}-1)-(2^{31}-1)$	0	reference unit	P	-	-
PtP0.29	Position of segment 14	Setting range	Default	Unit	Applicable mode		
		$-(2^{31}-1)-(2^{31}-1)$	0	reference unit	P	-	-
PtP0.31	Position of segment 15	Setting range	Default	Unit	Applicable mode		
		$-(2^{31}-1)-(2^{31}-1)$	0	reference unit	P	-	-
PtP0.33	Position of segment 16	Setting range	Default	Unit	Applicable mode		
		$-(2^{31}-1)-(2^{31}-1)$	0	reference unit	P	-	-
PtP0.35	Position of segment 17	Setting range	Default	Unit	Applicable mode		
		$-(2^{31}-1)-(2^{31}-1)$	0	reference unit	P	-	-
PtP0.37	Position of segment 18	Setting range	Default	Unit	Applicable mode		
		$-(2^{31}-1)-(2^{31}-1)$	0	reference unit	P	-	-
PtP0.39	Position of segment 19	Setting range	Default	Unit	Applicable mode		
		$-(2^{31}-1)-(2^{31}-1)$	0	reference unit	P	-	-

PtP0.41	Position of segment 20	Setting range	Default	Unit	Applicable mode		
		$-(2^{31}-1)-(2^{31}-1)$	0	reference unit	P	-	-
PtP0.43	Position of segment 21	Setting range	Default	Unit	Applicable mode		
		$-(2^{31}-1)-(2^{31}-1)$	0	reference unit	P	-	-
PtP0.45	Position of segment 22	Setting range	Default	Unit	Applicable mode		
		$-(2^{31}-1)-(2^{31}-1)$	0	reference unit	P	-	-
PtP0.47	Position of segment 23	Setting range	Default	Unit	Applicable mode		
		$-(2^{31}-1)-(2^{31}-1)$	0	reference unit	P	-	-
PtP0.49	Position of segment 24	Setting range	Default	Unit	Applicable mode		
		$-(2^{31}-1)-(2^{31}-1)$	0	reference unit	P	-	-
PtP0.51	Position of segment 25	Setting range	Default	Unit	Applicable mode		
		$-(2^{31}-1)-(2^{31}-1)$	0	reference unit	P	-	-
PtP0.53	Position of segment 26	Setting range	Default	Unit	Applicable mode		
		$-(2^{31}-1)-(2^{31}-1)$	0	reference unit	P	-	-
PtP0.55	Position of segment 27	Setting range	Default	Unit	Applicable mode		
		$-(2^{31}-1)-(2^{31}-1)$	0	reference unit	P	-	-
PtP0.57	Position of segment 28	Setting range	Default	Unit	Applicable mode		
		$-(2^{31}-1)-(2^{31}-1)$	0	reference unit	P	-	-
PtP0.59	Position of segment 29	Setting range	Default	Unit	Applicable mode		
		$-(2^{31}-1)-(2^{31}-1)$	0	reference unit	P	-	-
PtP0.61	Position of segment 30	Setting range	Default	Unit	Applicable mode		
		$-(2^{31}-1)-(2^{31}-1)$	0	reference unit	P	-	-
PtP0.63	Position of segment 31	Setting range	Default	Unit	Applicable mode		
		$-(2^{31}-1)-(2^{31}-1)$	0	reference unit	P	-	-
PtP0.65	Position of segment 32	Setting range	Default	Unit	Applicable mode		
		$-(2^{31}-1)-(2^{31}-1)$	0	reference unit	P	-	-

PtP0.67	Position of segment 33	Setting range	Default	Unit	Applicable mode		
		$-(2^{31}-1)-(2^{31}-1)$	0	reference unit	P	-	-
PtP0.69	Position of segment 34	Setting range	Default	Unit	Applicable mode		
		$-(2^{31}-1)-(2^{31}-1)$	0	reference unit	P	-	-
PtP0.71	Position of segment 35	Setting range	Default	Unit	Applicable mode		
		$-(2^{31}-1)-(2^{31}-1)$	0	reference unit	P	-	-
PtP0.73	Position of segment 36	Setting range	Default	Unit	Applicable mode		
		$-(2^{31}-1)-(2^{31}-1)$	0	reference unit	P	-	-
PtP0.75	Position of segment 37	Setting range	Default	Unit	Applicable mode		
		$-(2^{31}-1)-(2^{31}-1)$	0	reference unit	P	-	-
PtP0.77	Position of segment 38	Setting range	Default	Unit	Applicable mode		
		$-(2^{31}-1)-(2^{31}-1)$	0	reference unit	P	-	-
PtP0.79	Position of segment 39	Setting range	Default	Unit	Applicable mode		
		$-(2^{31}-1)-(2^{31}-1)$	0	reference unit	P	-	-
PtP0.81	Position of segment 40	Setting range	Default	Unit	Applicable mode		
		$-(2^{31}-1)-(2^{31}-1)$	0	reference unit	P	-	-
PtP0.83	Position of segment 41	Setting range	Default	Unit	Applicable mode		
		$-(2^{31}-1)-(2^{31}-1)$	0	reference unit	P	-	-
PtP0.85	Position of segment 42	Setting range	Default	Unit	Applicable mode		
		$-(2^{31}-1)-(2^{31}-1)$	0	reference unit	P	-	-
PtP0.87	Position of segment 43	Setting range	Default	Unit	Applicable mode		
		$-(2^{31}-1)-(2^{31}-1)$	0	reference unit	P	-	-
PtP0.89	Position of segment 44	Setting range	Default	Unit	Applicable mode		
		$-(2^{31}-1)-(2^{31}-1)$	0	reference unit	P	-	-
PtP0.91	Position of segment 45	Setting range	Default	Unit	Applicable mode		
		$-(2^{31}-1)-(2^{31}-1)$	0	reference unit	P	-	-

PtP0.93	Position of segment 46	Setting range	Default	Unit	Applicable mode		
		$-(2^{31}-1)-(2^{31}-1)$	0	reference unit	P	-	-
PtP0.95	Position of segment 47	Setting range	Default	Unit	Applicable mode		
		$-(2^{31}-1)-(2^{31}-1)$	0	reference unit	P	-	-
PtP0.97	Position of segment 48	Setting range	Default	Unit	Applicable mode		
		$-(2^{31}-1)-(2^{31}-1)$	0	reference unit	P	-	-
PtP0.99	Position of segment 49	Setting range	Default	Unit	Applicable mode		
		$-(2^{31}-1)-(2^{31}-1)$	0	reference unit	P	-	-

This group of parameters specify the positions of segment 01 to segment 49. The CMD attribute determines the command mode of this PTP position. P0.37 is inapplicable to this PTP position.

PtP0.03	Data size	32bit	Data format	DEC
	Modbus communication address	3206, 3207	CANopen communication address	0x2B03, 0x00
PtP0.05	Data size	32bit	Data format	DEC
	Modbus communication address	3210, 3211	CANopen communication address	0x2B05, 0x00
PtP0.07	Data size	32bit	Data format	DEC
	Modbus communication address	3214, 3015	CANopen communication address	0x2B07, 0x00
PtP0.09	Data size	32bit	Data format	DEC
	Modbus communication address	3218, 3219	CANopen communication address	0x2B09, 0x00
PtP0.11	Data size	32bit	Data format	DEC
	Modbus communication address	3222, 3223	CANopen communication address	0x2B0B, 0x00
PtP0.13	Data size	32bit	Data format	DEC
	Modbus communication address	3226, 3227	CANopen communication address	0x2B0D, 0x00

PtP0.15	Data size	32bit	Data format	DEC
	Modbus communication address	3230, 3231	CANopen communication address	0x2B0F, 0x00
PtP0.17	Data size	32bit	Data format	DEC
	Modbus communication address	3234, 3235	CANopen communication address	0x2B11, 0x00
PtP0.19	Data size	32bit	Data format	DEC
	Modbus communication address	3238, 3239	CANopen communication address	0x2B13, 0x00
PtP0.21	Data size	32bit	Data format	DEC
	Modbus communication address	3242, 3243	CANopen communication address	0x2B15, 0x00
PtP0.23	Data size	32bit	Data format	DEC
	Modbus communication address	3246, 3247	CANopen communication address	0x2B17, 0x00
PtP0.25	Data size	32bit	Data format	DEC
	Modbus communication address	3250, 3251	CANopen communication address	0x2B19, 0x00
PtP0.27	Data size	32bit	Data format	DEC
	Modbus communication address	3254, 3255	CANopen communication address	0x2B1B, 0x00
PtP0.29	Data size	32bit	Data format	DEC
	Modbus communication address	3258, 3259	CANopen communication address	0x2B1D, 0x00
PtP0.31	Data size	32bit	Data format	DEC
	Modbus communication address	3262, 3263	CANopen communication address	0x2B1F, 0x00
PtP0.33	Data size	32bit	Data format	DEC
	Modbus communication	3266, 3267	CANopen communication	0x2B21, 0x00

	address		address	
PtP0.35	Data size	32bit	Data format	DEC
	Modbus communication address	3270, 3271	CANopen communication address	0x2B23, 0x00
PtP0.37	Data size	32bit	Data format	DEC
	Modbus communication address	3274, 3075	CANopen communication address	0x2B25, 0x00
PtP0.39	Data size	32bit	Data format	DEC
	Modbus communication address	3278, 3279	CANopen communication address	0x2B27, 0x00
PtP0.41	Data size	32bit	Data format	DEC
	Modbus communication address	3282, 3283	CANopen communication address	0x2B29, 0x00
PtP0.43	Data size	32bit	Data format	DEC
	Modbus communication address	3286, 3287	CANopen communication address	0x2B2B, 0x00
PtP0.45	Data size	32bit	Data format	DEC
	Modbus communication address	3290, 3291	CANopen communication address	0x2B2D, 0x00
PtP0.47	Data size	32bit	Data format	DEC
	Modbus communication address	3294, 3295	CANopen communication address	0x2B2F, 0x00
PtP0.49	Data size	32bit	Data format	DEC
	Modbus communication address	3298, 3299	CANopen communication address	0x2B31, 0x00
PtP0.51	Data size	32bit	Data format	DEC
	Modbus communication address	3302, 3303	CANopen communication address	0x2B33, 0x00
PtP0.53	Data size	32bit	Data format	DEC
	Modbus	3306, 3307	CANopen	0x2B35, 0x00

	communication address		communication address	
PtP0.55	Data size	32bit	Data format	DEC
	Modbus communication address	3310, 3311	CANopen communication address	0x2B37, 0x00
PtP0.57	Data size	32bit	Data format	DEC
	Modbus communication address	3314, 3315	CANopen communication address	0x2B39, 0x00
PtP0.59	Data size	32bit	Data format	DEC
	Modbus communication address	3318, 3319	CANopen communication address	0x2B3B, 0x00
PtP0.61	Data size	32bit	Data format	DEC
	Modbus communication address	3322, 3323	CANopen communication address	0x2B3D, 0x00
PtP0.63	Data size	32bit	Data format	DEC
	Modbus communication address	3326, 3327	CANopen communication address	0x2B3F, 0x00
PtP0.65	Data size	32bit	Data format	DEC
	Modbus communication address	3330, 3331	CANopen communication address	0x2B41, 0x00
PtP0.67	Data size	32bit	Data format	DEC
	Modbus communication address	3334, 3335	CANopen communication address	0x2B43, 0x00
PtP0.69	Data size	32bit	Data format	DEC
	Modbus communication address	3338, 3339	CANopen communication address	0x2B45, 0x00
PtP0.71	Data size	32bit	Data format	DEC
	Modbus communication address	3342, 3343	CANopen communication address	0x2B47, 0x00
PtP0.73	Data size	32bit	Data format	DEC

	Modbus communication address	3346, 3347	CANopen communication address	0x2B49, 0x00
PtP0.75	Data size	32bit	Data format	DEC
	Modbus communication address	3350, 3351	CANopen communication address	0x2B4B, 0x00
PtP0.77	Data size	32bit	Data format	DEC
	Modbus communication address	3354, 3355	CANopen communication address	0x2B4D, 0x00
PtP0.79	Data size	32bit	Data format	DEC
	Modbus communication address	3358, 3359	CANopen communication address	0x2B4F, 0x00
PtP0.81	Data size	32bit	Data format	DEC
	Modbus communication address	3362, 3363	CANopen communication address	0x2B51, 0x00
PtP0.83	Data size	32bit	Data format	DEC
	Modbus communication address	3366, 3367	CANopen communication address	0x2B53, 0x00
PtP0.85	Data size	32bit	Data format	DEC
	Modbus communication address	3370, 3371	CANopen communication address	0x2B55, 0x00
PtP0.87	Data size	32bit	Data format	DEC
	Modbus communication address	3374, 3375	CANopen communication address	0x2B57, 0x00
PtP0.89	Data size	32bit	Data format	DEC
	Modbus communication address	3378, 3379	CANopen communication address	0x2B59, 0x00
PtP0.91	Data size	32bit	Data format	DEC
	Modbus communication address	3382, 3383	CANopen communication address	0x2B5B, 0x00

PtP0.93	Data size	32bit	Data format	DEC
	Modbus communication address	3386, 3387	CANopen communication address	0x2B5D, 0x00
PtP0.95	Data size	32bit	Data format	DEC
	Modbus communication address	3390, 3391	CANopen communication address	0x2B5F, 0x00
PtP0.97	Data size	32bit	Data format	DEC
	Modbus communication address	3394, 3395	CANopen communication address	0x2B61, 0x00
PtP0.99	Data size	32bit	Data format	DEC
	Modbus communication address	3398, 3399	CANopen communication address	0x2B63, 0x00

PtP1.00	Control word of segment 50	Setting range	Default	Unit	Applicable mode		
		0-0x7FFFFFFF	0x00000000	-	P	-	-
PtP1.02	Control word of segment 51	Setting range	Default	Unit	Applicable mode		
		0-0x7FFFFFFF	0x00000000	-	P	-	-
PtP1.04	Control word of segment 52	Setting range	Default	Unit	Applicable mode		
		0-0x7FFFFFFF	0x00000000	-	P	-	-
PtP1.06	Control word of segment 53	Setting range	Default	Unit	Applicable mode		
		0-0x7FFFFFFF	0x00000000	-	P	-	-
PtP1.08	Control word of segment 54	Setting range	Default	Unit	Applicable mode		
		0-0x7FFFFFFF	0x00000000	-	P	-	-
PtP1.10	Control word of segment 55	Setting range	Default	Unit	Applicable mode		
		0-0x7FFFFFFF	0x00000000	-	P	-	-
PtP1.12	Control word of segment 56	Setting range	Default	Unit	Applicable mode		
		0-0x7FFFFFFF	0x00000000	-	P	-	-

PtP1.14	Control word of segment 57	Setting range	Default	Unit	Applicable mode		
		0-0x7FFFFFFF	0x00000000	-	P	-	-
PtP1.16	Control word of segment 58	Setting range	Default	Unit	Applicable mode		
		0-0x7FFFFFFF	0x00000000	-	P	-	-
PtP1.18	Control word of segment 59	Setting range	Default	Unit	Applicable mode		
		0-0x7FFFFFFF	0x00000000	-	P	-	-
PtP1.20	Control word of segment 60	Setting range	Default	Unit	Applicable mode		
		0-0x7FFFFFFF	0x00000000	-	P	-	-
PtP1.22	Control word of segment 61	Setting range	Default	Unit	Applicable mode		
		0-0x7FFFFFFF	0x00000000	-	P	-	-
PtP1.24	Control word of segment 62	Setting range	Default	Unit	Applicable mode		
		0-0x7FFFFFFF	0x00000000	-	P	-	-
PtP1.26	Control word of segment 63	Setting range	Default	Unit	Applicable mode		
		0-0x7FFFFFFF	0x00000000	-	P	-	-
PtP1.28	Control word of segment 64	Setting range	Default	Unit	Applicable mode		
		0-0x7FFFFFFF	0x00000000	-	P	-	-
PtP1.30	Control word of segment 65	Setting range	Default	Unit	Applicable mode		
		0-0x7FFFFFFF	0x00000000	-	P	-	-
PtP1.32	Control word of segment 66	Setting range	Default	Unit	Applicable mode		
		0-0x7FFFFFFF	0x00000000	-	P	-	-
PtP1.34	Control word of segment 67	Setting range	Default	Unit	Applicable mode		
		0-0x7FFFFFFF	0x00000000	-	P	-	-
PtP1.36	Control word of segment 68	Setting range	Default	Unit	Applicable mode		
		0-0x7FFFFFFF	0x00000000	-	P	-	-
PtP1.38	Control word of segment 69	Setting range	Default	Unit	Applicable mode		
		0-0x7FFFFFFF	0x00000000	-	P	-	-

PtP1.40	Control word of segment 70	Setting range	Default	Unit	Applicable mode		
		0-0x7FFFFFFF	0x00000000	-	P	-	-
PtP1.42	Control word of segment 71	Setting range	Default	Unit	Applicable mode		
		0-0x7FFFFFFF	0x00000000	-	P	-	-
PtP1.44	Control word of segment 72	Setting range	Default	Unit	Applicable mode		
		0-0x7FFFFFFF	0x00000000	-	P	-	-
PtP1.46	Control word of segment 73	Setting range	Default	Unit	Applicable mode		
		0-0x7FFFFFFF	0x00000000	-	P	-	-
PtP1.48	Control word of segment 74	Setting range	Default	Unit	Applicable mode		
		0-0x7FFFFFFF	0x00000000	-	P	-	-
PtP1.50	Control word of segment 75	Setting range	Default	Unit	Applicable mode		
		0-0x7FFFFFFF	0x00000000	-	P	-	-
PtP1.52	Control word of segment 76	Setting range	Default	Unit	Applicable mode		
		0-0x7FFFFFFF	0x00000000	-	P	-	-
PtP1.54	Control word of segment 77	Setting range	Default	Unit	Applicable mode		
		0-0x7FFFFFFF	0x00000000	-	P	-	-
PtP1.56	Control word of segment 78	Setting range	Default	Unit	Applicable mode		
		0-0x7FFFFFFF	0x00000000	-	P	-	-
PtP1.58	Control word of segment 79	Setting range	Default	Unit	Applicable mode		
		0-0x7FFFFFFF	0x00000000	-	P	-	-
PtP1.60	Control word of segment 80	Setting range	Default	Unit	Applicable mode		
		0-0x7FFFFFFF	0x00000000	-	P	-	-
PtP1.62	Control word of segment 81	Setting range	Default	Unit	Applicable mode		
		0-0x7FFFFFFF	0x00000000	-	P	-	-
PtP1.64	Control word of segment 82	Setting range	Default	Unit	Applicable mode		
		0-0x7FFFFFFF	0x00000000	-	P	-	-

PtP1.66	Control word of segment 83	Setting range	Default	Unit	Applicable mode		
		0-0x7FFFFFFF	0x00000000	-	P	-	-
PtP1.68	Control word of segment 84	Setting range	Default	Unit	Applicable mode		
		0-0x7FFFFFFF	0x00000000	-	P	-	-
PtP1.70	Control word of segment 85	Setting range	Default	Unit	Applicable mode		
		0-0x7FFFFFFF	0x00000000	-	P	-	-
PtP1.72	Control word of segment 86	Setting range	Default	Unit	Applicable mode		
		0-0x7FFFFFFF	0x00000000	-	P	-	-
PtP1.74	Control word of segment 87	Setting range	Default	Unit	Applicable mode		
		0-0x7FFFFFFF	0x00000000	-	P	-	-
PtP1.76	Control word of segment 88	Setting range	Default	Unit	Applicable mode		
		0-0x7FFFFFFF	0x00000000	-	P	-	-
PtP1.78	Control word of segment 89	Setting range	Default	Unit	Applicable mode		
		0-0x7FFFFFFF	0x00000000	-	P	-	-
PtP1.80	Control word of segment 90	Setting range	Default	Unit	Applicable mode		
		0-0x7FFFFFFF	0x00000000	-	P	-	-
PtP1.82	Control word of segment 91	Setting range	Default	Unit	Applicable mode		
		0-0x7FFFFFFF	0x00000000	-	P	-	-
PtP1.84	Control word of segment 92	Setting range	Default	Unit	Applicable mode		
		0-0x7FFFFFFF	0x00000000	-	P	-	-
PtP1.86	Control word of segment 93	Setting range	Default	Unit	Applicable mode		
		0-0x7FFFFFFF	0x00000000	-	P	-	-
PtP1.88	Control word of segment 94	Setting range	Default	Unit	Applicable mode		
		0-0x7FFFFFFF	0x00000000	-	P	-	-
PtP1.90	Control word of segment 95	Setting range	Default	Unit	Applicable mode		
		0-0x7FFFFFFF	0x00000000	-	P	-	-

PtP1.92	Control word of segment 96	Setting range	Default	Unit	Applicable mode		
		0-0x7FFFFFFF	0x00000000	-	P	-	-
PtP1.94	Control word of segment 97	Setting range	Default	Unit	Applicable mode		
		0-0x7FFFFFFF	0x00000000	-	P	-	-
PtP1.96	Control word of segment 98	Setting range	Default	Unit	Applicable mode		
		0-0x7FFFFFFF	0x00000000	-	P	-	-
PtP1.98	Control word of segment 99	Setting range	Default	Unit	Applicable mode		
		0-0x7FFFFFFF	0x00000000	-	P	-	-

This group of parameters specify the control words of segment 50 to segment 99. For details, see the description for PtP0.00.

PtP1.00	Data size	32bit	Data format	HEX
	Modbus communication address	3400, 3401	CANopen communication address	0x2C00, 0x00
PtP1.02	Data size	32bit	Data format	HEX
	Modbus communication address	3404, 3405	CANopen communication address	0x2C02, 0x00
PtP1.04	Data size	32bit	Data format	HEX
	Modbus communication address	3408, 3409	CANopen communication address	0x2C04, 0x00
PtP1.06	Data size	32bit	Data format	HEX
	Modbus communication address	3412, 3413	CANopen communication address	0x2C06, 0x00
PtP1.08	Data size	32bit	Data format	HEX
	Modbus communication address	3416, 3417	CANopen communication address	0x2C08, 0x00
PtP1.10	Data size	32bit	Data format	HEX
	Modbus communication address	3420, 3421	CANopen communication address	0x2C0A, 0x00
PtP1.12	Data size	32bit	Data format	HEX

	Modbus communication address	3424, 3425	CANopen communication address	0x2C0C, 0x00
PtP1.14	Data size	32bit	Data format	HEX
	Modbus communication address	3428, 3429	CANopen communication address	0x2C0E, 0x00
PtP1.16	Data size	32bit	Data format	HEX
	Modbus communication address	3432, 3433	CANopen communication address	0x2C10, 0x00
PtP1.18	Data size	32bit	Data format	HEX
	Modbus communication address	3436, 3437	CANopen communication address	0x2C12, 0x00
PtP1.20	Data size	32bit	Data format	HEX
	Modbus communication address	3440, 3441	CANopen communication address	0x2C14, 0x00
PtP1.22	Data size	32bit	Data format	HEX
	Modbus communication address	3444, 3445	CANopen communication address	0x2C16, 0x00
PtP1.24	Data size	32bit	Data format	HEX
	Modbus communication address	3448, 3449	CANopen communication address	0x2C18, 0x00
PtP1.26	Data size	32bit	Data format	HEX
	Modbus communication address	3452, 3453	CANopen communication address	0x2C1A, 0x00
PtP1.28	Data size	32bit	Data format	HEX
	Modbus communication address	3456, 3457	CANopen communication address	0x2C1C, 0x00
PtP1.30	Data size	32bit	Data format	HEX
	Modbus communication address	3460, 3461	CANopen communication address	0x2C1E, 0x00

PtP1.32	Data size	32bit	Data format	HEX
	Modbus communication address	3464, 3465	CANopen communication address	0x2C20, 0x00
PtP1.34	Data size	32bit	Data format	HEX
	Modbus communication address	3468, 3469	CANopen communication address	0x2C22, 0x00
PtP1.36	Data size	32bit	Data format	HEX
	Modbus communication address	3472, 3473	CANopen communication address	0x2C24, 0x00
PtP1.38	Data size	32bit	Data format	HEX
	Modbus communication address	3476, 3477	CANopen communication address	0x2C26, 0x00
PtP1.40	Data size	32bit	Data format	HEX
	Modbus communication address	3480, 3481	CANopen communication address	0x2C28, 0x00
PtP1.42	Data size	32bit	Data format	HEX
	Modbus communication address	3484, 3485	CANopen communication address	0x2C2A, 0x00
PtP1.44	Data size	32bit	Data format	HEX
	Modbus communication address	3488, 3489	CANopen communication address	0x2C2C, 0x00
PtP1.46	Data size	32bit	Data format	HEX
	Modbus communication address	3492, 3493	CANopen communication address	0x2C2E, 0x00
PtP1.48	Data size	32bit	Data format	HEX
	Modbus communication address	3496, 3497	CANopen communication address	0x2C30, 0x00
PtP1.50	Data size	32bit	Data format	HEX
	Modbus communication	3500, 3501	CANopen communication	0x2C32, 0x00

	address		address	
PtP1.52	Data size	32bit	Data format	HEX
	Modbus communication address	3504, 3505	CANopen communication address	0x2C34, 0x00
PtP1.54	Data size	32bit	Data format	HEX
	Modbus communication address	3508, 3509	CANopen communication address	0x2C36, 0x00
PtP1.56	Data size	32bit	Data format	HEX
	Modbus communication address	3512, 3513	CANopen communication address	0x2C38, 0x00
PtP1.58	Data size	32bit	Data format	HEX
	Modbus communication address	3516, 3517	CANopen communication address	0x2C3A, 0x00
PtP1.60	Data size	32bit	Data format	HEX
	Modbus communication address	3520, 3521	CANopen communication address	0x2C3C, 0x00
PtP1.62	Data size	32bit	Data format	HEX
	Modbus communication address	3524, 3525	CANopen communication address	0x2C3E, 0x00
PtP1.64	Data size	32bit	Data format	HEX
	Modbus communication address	3528, 3529	CANopen communication address	0x2C40, 0x00
PtP1.66	Data size	32bit	Data format	HEX
	Modbus communication address	3532, 3533	CANopen communication address	0x2C42, 0x00
PtP1.68	Data size	32bit	Data format	HEX
	Modbus communication address	3536, 3537	CANopen communication address	0x2C44, 0x00
PtP1.70	Data size	32bit	Data format	HEX
	Modbus	3540, 3541	CANopen	0x2C46, 0x00

	communication address		communication address	
PtP1.72	Data size	32bit	Data format	HEX
	Modbus communication address	3544, 3545	CANopen communication address	0x2C48, 0x00
PtP1.74	Data size	32bit	Data format	HEX
	Modbus communication address	3548, 3549	CANopen communication address	0x2C4A, 0x00
PtP1.76	Data size	32bit	Data format	HEX
	Modbus communication address	3552, 3553	CANopen communication address	0x2C4C, 0x00
PtP1.78	Data size	32bit	Data format	HEX
	Modbus communication address	3556, 3557	CANopen communication address	0x2C4E, 0x00
PtP1.80	Data size	32bit	Data format	HEX
	Modbus communication address	3560, 3561	CANopen communication address	0x2C50, 0x00
PtP1.82	Data size	32bit	Data format	HEX
	Modbus communication address	3564, 3565	CANopen communication address	0x2C52, 0x00
PtP1.84	Data size	32bit	Data format	HEX
	Modbus communication address	3568, 3569	CANopen communication address	0x2C54, 0x00
PtP1.86	Data size	32bit	Data format	HEX
	Modbus communication address	3572, 3573	CANopen communication address	0x2C56, 0x00
PtP1.88	Data size	32bit	Data format	HEX
	Modbus communication address	3576, 3577	CANopen communication address	0x2C58, 0x00
PtP1.90	Data size	32bit	Data format	HEX

	Modbus communication address	3580, 3581	CANopen communication address	0x2C5A, 0x00
PtP1.92	Data size	32bit	Data format	HEX
	Modbus communication address	3584, 3585	CANopen communication address	0x2C5C, 0x00
PtP1.94	Data size	32bit	Data format	HEX
	Modbus communication address	3588, 3589	CANopen communication address	0x2C5E, 0x00
PtP1.96	Data size	32bit	Data format	HEX
	Modbus communication address	3592, 3593	CANopen communication address	0x2C60, 0x00
PtP1.98	Data size	32bit	Data format	HEX
	Modbus communication address	3596, 3597	CANopen communication address	0x2C62, 0x00

PtP1.01	Position of segment 50	Setting range	Default	Unit	Applicable mode		
		$-(2^{31}-1)-(2^{31}-1)$	0	reference unit	P	-	-
PtP1.03	Position of segment 51	Setting range	Default	Unit	Applicable mode		
		$-(2^{31}-1)-(2^{31}-1)$	0	reference unit	P	-	-
PtP1.05	Position of segment 52	Setting range	Default	Unit	Applicable mode		
		$-(2^{31}-1)-(2^{31}-1)$	0	reference unit	P	-	-
PtP1.07	Position of segment 53	Setting range	Default	Unit	Applicable mode		
		$-(2^{31}-1)-(2^{31}-1)$	0	reference unit	P	-	-
PtP1.09	Position of segment 54	Setting range	Default	Unit	Applicable mode		
		$-(2^{31}-1)-(2^{31}-1)$	0	reference unit	P	-	-
PtP1.11	Position of segment 55	Setting range	Default	Unit	Applicable mode		
		$-(2^{31}-1)-(2^{31}-1)$	0	reference unit	P	-	-

PtP1.13	Position of segment 56	Setting range	Default	Unit	Applicable mode		
		$-(2^{31}-1)-(2^{31}-1)$	0	reference unit	P	-	-
PtP1.15	Position of segment 57	Setting range	Default	Unit	Applicable mode		
		$-(2^{31}-1)-(2^{31}-1)$	0	reference unit	P	-	-
PtP1.17	Position of segment 58	Setting range	Default	Unit	Applicable mode		
		$-(2^{31}-1)-(2^{31}-1)$	0	reference unit	P	-	-
PtP1.19	Position of segment 59	Setting range	Default	Unit	Applicable mode		
		$-(2^{31}-1)-(2^{31}-1)$	0	reference unit	P	-	-
PtP1.21	Position of segment 60	Setting range	Default	Unit	Applicable mode		
		$-(2^{31}-1)-(2^{31}-1)$	0	reference unit	P	-	-
PtP1.23	Position of segment 61	Setting range	Default	Unit	Applicable mode		
		$-(2^{31}-1)-(2^{31}-1)$	0	reference unit	P	-	-
PtP1.25	Position of segment 62	Setting range	Default	Unit	Applicable mode		
		$-(2^{31}-1)-(2^{31}-1)$	0	reference unit	P	-	-
PtP1.27	Position of segment 63	Setting range	Default	Unit	Applicable mode		
		$-(2^{31}-1)-(2^{31}-1)$	0	reference unit	P	-	-
PtP1.29	Position of segment 64	Setting range	Default	Unit	Applicable mode		
		$-(2^{31}-1)-(2^{31}-1)$	0	reference unit	P	-	-
PtP1.31	Position of segment 65	Setting range	Default	Unit	Applicable mode		
		$-(2^{31}-1)-(2^{31}-1)$	0	reference unit	P	-	-
PtP1.33	Position of segment 66	Setting range	Default	Unit	Applicable mode		
		$-(2^{31}-1)-(2^{31}-1)$	0	reference unit	P	-	-
PtP1.35	Position of segment 67	Setting range	Default	Unit	Applicable mode		
		$-(2^{31}-1)-(2^{31}-1)$	0	reference unit	P	-	-
PtP1.37	Position of segment 68	Setting range	Default	Unit	Applicable mode		
		$-(2^{31}-1)-(2^{31}-1)$	0	reference unit	P	-	-

PtP1.39	Position of segment 69	Setting range	Default	Unit	Applicable mode		
		$-(2^{31}-1)-(2^{31}-1)$	0	reference unit	P	-	-
PtP1.41	Position of segment 70	Setting range	Default	Unit	Applicable mode		
		$-(2^{31}-1)-(2^{31}-1)$	0	reference unit	P	-	-
PtP1.43	Position of segment 71	Setting range	Default	Unit	Applicable mode		
		$-(2^{31}-1)-(2^{31}-1)$	0	reference unit	P	-	-
PtP1.45	Position of segment 72	Setting range	Default	Unit	Applicable mode		
		$-(2^{31}-1)-(2^{31}-1)$	0	reference unit	P	-	-
PtP1.47	Position of segment 73	Setting range	Default	Unit	Applicable mode		
		$-(2^{31}-1)-(2^{31}-1)$	0	reference unit	P	-	-
PtP1.49	Position of segment 74	Setting range	Default	Unit	Applicable mode		
		$-(2^{31}-1)-(2^{31}-1)$	0	reference unit	P	-	-
PtP1.51	Position of segment 75	Setting range	Default	Unit	Applicable mode		
		$-(2^{31}-1)-(2^{31}-1)$	0	reference unit	P	-	-
PtP1.53	Position of segment 76	Setting range	Default	Unit	Applicable mode		
		$-(2^{31}-1)-(2^{31}-1)$	0	reference unit	P	-	-
PtP1.55	Position of segment 77	Setting range	Default	Unit	Applicable mode		
		$-(2^{31}-1)-(2^{31}-1)$	0	reference unit	P	-	-
PtP1.57	Position of segment 78	Setting range	Default	Unit	Applicable mode		
		$-(2^{31}-1)-(2^{31}-1)$	0	reference unit	P	-	-
PtP1.59	Position of segment 79	Setting range	Default	Unit	Applicable mode		
		$-(2^{31}-1)-(2^{31}-1)$	0	reference unit	P	-	-
PtP1.61	Position of segment 80	Setting range	Default	Unit	Applicable mode		
		$-(2^{31}-1)-(2^{31}-1)$	0	reference unit	P	-	-
PtP1.63	Position of segment 81	Setting range	Default	Unit	Applicable mode		
		$-(2^{31}-1)-(2^{31}-1)$	0	reference unit	P	-	-

PtP1.65	Position of segment 82	Setting range	Default	Unit	Applicable mode		
		$-(2^{31}-1)-(2^{31}-1)$	0	reference unit	P	-	-
PtP1.67	Position of segment 83	Setting range	Default	Unit	Applicable mode		
		$-(2^{31}-1)-(2^{31}-1)$	0	reference unit	P	-	-
PtP1.69	Position of segment 84	Setting range	Default	Unit	Applicable mode		
		$-(2^{31}-1)-(2^{31}-1)$	0	reference unit	P	-	-
PtP1.71	Position of segment 85	Setting range	Default	Unit	Applicable mode		
		$-(2^{31}-1)-(2^{31}-1)$	0	reference unit	P	-	-
PtP1.73	Position of segment 86	Setting range	Default	Unit	Applicable mode		
		$-(2^{31}-1)-(2^{31}-1)$	0	reference unit	P	-	-
PtP1.75	Position of segment 87	Setting range	Default	Unit	Applicable mode		
		$-(2^{31}-1)-(2^{31}-1)$	0	reference unit	P	-	-
PtP1.77	Position of segment 88	Setting range	Default	Unit	Applicable mode		
		$-(2^{31}-1)-(2^{31}-1)$	0	reference unit	P	-	-
PtP1.79	Position of segment 89	Setting range	Default	Unit	Applicable mode		
		$-(2^{31}-1)-(2^{31}-1)$	0	reference unit	P	-	-
PtP1.81	Position of segment 90	Setting range	Default	Unit	Applicable mode		
		$-(2^{31}-1)-(2^{31}-1)$	0	reference unit	P	-	-
PtP1.83	Position of segment 91	Setting range	Default	Unit	Applicable mode		
		$-(2^{31}-1)-(2^{31}-1)$	0	reference unit	P	-	-
PtP1.85	Position of segment 92	Setting range	Default	Unit	Applicable mode		
		$-(2^{31}-1)-(2^{31}-1)$	0	reference unit	P	-	-
PtP1.87	Position of segment 93	Setting range	Default	Unit	Applicable mode		
		$-(2^{31}-1)-(2^{31}-1)$	0	reference unit	P	-	-
PtP1.89	Position of segment 94	Setting range	Default	Unit	Applicable mode		
		$-(2^{31}-1)-(2^{31}-1)$	0	reference unit	P	-	-

PtP1.91	Position of segment 95	Setting range	Default	Unit	Applicable mode		
		$-(2^{31}-1)-(2^{31}-1)$	0	reference unit	P	-	-
PtP1.93	Position of segment 96	Setting range	Default	Unit	Applicable mode		
		$-(2^{31}-1)-(2^{31}-1)$	0	reference unit	P	-	-
PtP1.95	Position of segment 97	Setting range	Default	Unit	Applicable mode		
		$-(2^{31}-1)-(2^{31}-1)$	0	reference unit	P	-	-
PtP1.97	Position of segment 98	Setting range	Default	Unit	Applicable mode		
		$-(2^{31}-1)-(2^{31}-1)$	0	reference unit	P	-	-
PtP1.99	Position of segment 99	Setting range	Default	Unit	Applicable mode		
		$-(2^{31}-1)-(2^{31}-1)$	0	reference unit	P	-	-

This group of parameters specify the positions of segment 50 to segment 99. The CMD attribute determines the command mode of this PTP position. P0.37 is inapplicable to this PTP position.

PtP1.01	Data size	32bit	Data format	DEC
	Modbus communication address	3402, 3403	CANopen communication address	0x2C03, 0x00
PtP1.03	Data size	32bit	Data format	DEC
	Modbus communication address	3406, 3407	CANopen communication address	0x2C03, 0x00
PtP1.05	Data size	32bit	Data format	DEC
	Modbus communication address	3410, 3411	CANopen communication address	0x2C05, 0x00
PtP1.07	Data size	32bit	Data format	DEC
	Modbus communication address	3414, 3415	CANopen communication address	0x2C07, 0x00
PtP1.09	Data size	32bit	Data format	DEC
	Modbus communication address	3418, 3419	CANopen communication address	0x2C09, 0x00
PtP1.11	Data size	32bit	Data format	DEC

	Modbus communication address	3422, 3423	CANopen communication address	0x2C0B, 0x00
PtP1.13	Data size	32bit	Data format	DEC
	Modbus communication address	3426, 3427	CANopen communication address	0x2C0D, 0x00
PtP1.15	Data size	32bit	Data format	DEC
	Modbus communication address	3430, 3431	CANopen communication address	0x2C0F, 0x00
PtP1.17	Data size	32bit	Data format	DEC
	Modbus communication address	3434, 3435	CANopen communication address	0x2C11, 0x00
PtP1.19	Data size	32bit	Data format	DEC
	Modbus communication address	3438, 3439	CANopen communication address	0x2C13, 0x00
PtP1.21	Data size	32bit	Data format	DEC
	Modbus communication address	3442, 3443	CANopen communication address	0x2C15, 0x00
PtP1.23	Data size	32bit	Data format	DEC
	Modbus communication address	3446, 3447	CANopen communication address	0x2C17, 0x00
PtP1.25	Data size	32bit	Data format	DEC
	Modbus communication address	3450, 3451	CANopen communication address	0x2C19, 0x00
PtP1.27	Data size	32bit	Data format	DEC
	Modbus communication address	3454, 3455	CANopen communication address	0x2C1B, 0x00
PtP1.29	Data size	32bit	Data format	DEC
	Modbus communication address	3458, 3459	CANopen communication address	0x2C1D, 0x00

PtP1.31	Data size	32bit	Data format	DEC
	Modbus communication address	3462, 3463	CANopen communication address	0x2C1F, 0x00
PtP1.33	Data size	32bit	Data format	DEC
	Modbus communication address	3466, 3467	CANopen communication address	0x2C21, 0x00
PtP1.35	Data size	32bit	Data format	DEC
	Modbus communication address	3470, 3471	CANopen communication address	0x2C23, 0x00
PtP1.37	Data size	32bit	Data format	DEC
	Modbus communication address	3474, 3475	CANopen communication address	0x2C25, 0x00
PtP1.39	Data size	32bit	Data format	DEC
	Modbus communication address	3478, 3479	CANopen communication address	0x2C27, 0x00
PtP1.41	Data size	32bit	Data format	DEC
	Modbus communication address	3482, 3483	CANopen communication address	0x2C29, 0x00
PtP1.43	Data size	32bit	Data format	DEC
	Modbus communication address	3486, 3487	CANopen communication address	0x2C2B, 0x00
PtP1.45	Data size	32bit	Data format	DEC
	Modbus communication address	3490, 3491	CANopen communication address	0x2C2D, 0x00
PtP1.47	Data size	32bit	Data format	DEC
	Modbus communication address	3494, 3495	CANopen communication address	0x2C2F, 0x00
PtP1.49	Data size	32bit	Data format	DEC
	Modbus communication	3498, 3499	CANopen communication address	0x2C31, 0x00

	address			
PtP1.51	Data size	32bit	Data format	DEC
	Modbus communication address	3502, 3503	CANopen communication address	0x2C33, 0x00
PtP1.53	Data size	32bit	Data format	DEC
	Modbus communication address	3506, 3507	CANopen communication address	0x2C35, 0x00
PtP1.55	Data size	32bit	Data format	DEC
	Modbus communication address	3510, 3511	CANopen communication address	0x2C37, 0x00
PtP1.57	Data size	32bit	Data format	DEC
	Modbus communication address	3514, 3515	CANopen communication address	0x2C39, 0x00
PtP1.59	Data size	32bit	Data format	DEC
	Modbus communication address	3518, 3519	CANopen communication address	0x2C3B, 0x00
PtP1.61	Data size	32bit	Data format	DEC
	Modbus communication address	3522, 3523	CANopen communication address	0x2C3D, 0x00
PtP1.63	Data size	32bit	Data format	DEC
	Modbus communication address	3526, 3527	CANopen communication address	0x2C3F, 0x00
PtP1.65	Data size	32bit	Data format	DEC
	Modbus communication address	3530, 3531	CANopen communication address	0x2C41, 0x00
PtP1.67	Data size	32bit	Data format	DEC
	Modbus communication address	3534, 3535	CANopen communication address	0x2C43, 0x00
PtP1.69	Data size	32bit	Data format	DEC
	Modbus	3538, 3539	CANopen communication	0x2C45, 0x00

	communication address		address	
PtP1.71	Data size	32bit	Data format	DEC
	Modbus communication address	3542, 3543	CANopen communication address	0x2C47, 0x00
PtP1.73	Data size	32bit	Data format	DEC
	Modbus communication address	3546, 3547	CANopen communication address	0x2C49, 0x00
PtP1.75	Data size	32bit	Data format	DEC
	Modbus communication address	3550, 3551	CANopen communication address	0x2C4B, 0x00
PtP1.77	Data size	32bit	Data format	DEC
	Modbus communication address	3554, 3555	CANopen communication address	0x2C4D, 0x00
PtP1.79	Data size	32bit	Data format	DEC
	Modbus communication address	3558, 3559	CANopen communication address	0x2C4F, 0x00
PtP1.81	Data size	32bit	Data format	DEC
	Modbus communication address	3562, 3563	CANopen communication address	0x2C51, 0x00
PtP1.83	Data size	32bit	Data format	DEC
	Modbus communication address	3566, 3567	CANopen communication address	0x2C53, 0x00
PtP1.85	Data size	32bit	Data format	DEC
	Modbus communication address	3570, 3571	CANopen communication address	0x2C55, 0x00
PtP1.87	Data size	32bit	Data format	DEC
	Modbus communication address	3574, 3575	CANopen communication address	0x2C57, 0x00
PtP1.89	Data size	32bit	Data format	DEC

	Modbus communication address	3578, 3579	CANopen communication address	0x2C59, 0x00
PtP1.91	Data size	32bit	Data format	DEC
	Modbus communication address	3582, 3583	CANopen communication address	0x2C5B, 0x00
PtP1.93	Data size	32bit	Data format	DEC
	Modbus communication address	3586, 3587	CANopen communication address	0x2C5D, 0x00
PtP1.95	Data size	32bit	Data format	DEC
	Modbus communication address	3590, 3591	CANopen communication address	0x2C5F, 0x00
PtP1.97	Data size	32bit	Data format	DEC
	Modbus communication address	3594, 3595	CANopen communication address	0x2C61, 0x00
PtP1.99	Data size	32bit	Data format	DEC
	Modbus communication address	3598, 3599	CANopen communication address	0x2C63, 0x00

PtP2.00	Control word of segment 100	Setting range	Default	Unit	Applicable mode		
		0-0x7FFFFFFF	0x00000000	-	P	-	-
PtP2.02	Control word of segment 101	Setting range	Default	Unit	Applicable mode		
		0-0x7FFFFFFF	0x00000000	-	P	-	-
PtP2.04	Control word of segment 102	Setting range	Default	Unit	Applicable mode		
		0-0x7FFFFFFF	0x00000000	-	P	-	-
PtP2.06	Control word of segment 103	Setting range	Default	Unit	Applicable mode		
		0-0x7FFFFFFF	0x00000000	-	P	-	-
PtP2.08	Control word of segment 104	Setting range	Default	Unit	Applicable mode		
		0-0x7FFFFFFF	0x00000000	-	P	-	-

PtP2.10	Control word of segment 105	Setting range	Default	Unit	Applicable mode		
		0-0x7FFFFFFF	0x00000000	-	P	-	-
PtP2.12	Control word of segment 106	Setting range	Default	Unit	Applicable mode		
		0-0x7FFFFFFF	0x00000000	-	P	-	-
PtP2.14	Control word of segment 107	Setting range	Default	Unit	Applicable mode		
		0-0x7FFFFFFF	0x00000000	-	P	-	-
PtP2.16	Control word of segment 108	Setting range	Default	Unit	Applicable mode		
		0-0x7FFFFFFF	0x00000000	-	P	-	-
PtP2.18	Control word of segment 109	Setting range	Default	Unit	Applicable mode		
		0-0x7FFFFFFF	0x00000000	-	P	-	-
PtP2.20	Control word of segment 110	Setting range	Default	Unit	Applicable mode		
		0-0x7FFFFFFF	0x00000000	-	P	-	-
PtP2.22	Control word of segment 111	Setting range	Default	Unit	Applicable mode		
		0-0x7FFFFFFF	0x00000000	-	P	-	-
PtP2.24	Control word of segment 112	Setting range	Default	Unit	Applicable mode		
		0-0x7FFFFFFF	0x00000000	-	P	-	-
PtP2.26	Control word of segment 113	Setting range	Default	Unit	Applicable mode		
		0-0x7FFFFFFF	0x00000000	-	P	-	-
PtP2.28	Control word of segment 114	Setting range	Default	Unit	Applicable mode		
		0-0x7FFFFFFF	0x00000000	-	P	-	-
PtP2.30	Control word of segment 115	Setting range	Default	Unit	Applicable mode		
		0-0x7FFFFFFF	0x00000000	-	P	-	-
PtP2.32	Control word of segment 116	Setting range	Default	Unit	Applicable mode		
		0-0x7FFFFFFF	0x00000000	-	P	-	-
PtP2.34	Control word of segment 117	Setting range	Default	Unit	Applicable mode		
		0-0x7FFFFFFF	0x00000000	-	P	-	-

PtP2.36	Control word of segment 118	Setting range	Default	Unit	Applicable mode		
		0-0x7FFFFFFF	0x00000000	-	P	-	-
PtP2.38	Control word of segment 119	Setting range	Default	Unit	Applicable mode		
		0-0x7FFFFFFF	0x00000000	-	P	-	-
PtP2.40	Control word of segment 120	Setting range	Default	Unit	Applicable mode		
		0-0x7FFFFFFF	0x00000000	-	P	-	-
PtP2.42	Control word of segment 121	Setting range	Default	Unit	Applicable mode		
		0-0x7FFFFFFF	0x00000000	-	P	-	-
PtP2.44	Control word of segment 122	Setting range	Default	Unit	Applicable mode		
		0-0x7FFFFFFF	0x00000000	-	P	-	-
PtP2.46	Control word of segment 123	Setting range	Default	Unit	Applicable mode		
		0-0x7FFFFFFF	0x00000000	-	P	-	-
PtP2.48	Control word of segment 124	Setting range	Default	Unit	Applicable mode		
		0-0x7FFFFFFF	0x00000000	-	P	-	-
PtP2.50	Control word of segment 125	Setting range	Default	Unit	Applicable mode		
		0-0x7FFFFFFF	0x00000000	-	P	-	-
PtP2.52	Control word of segment 126	Setting range	Default	Unit	Applicable mode		
		0-0x7FFFFFFF	0x00000000	-	P	-	-
PtP2.54	Control word of segment 127	Setting range	Default	Unit	Applicable mode		
		0-0x7FFFFFFF	0x00000000	-	P	-	-
This group of parameters specify the control words of segment 100 to segment 127. For details, see the description for PtP0.00.							
PtP2.00	Data size	32bit	Data format		HEX		
	Modbus communication address	3600, 3601	CANopen communication address		0x2D00, 0x00		
PtP2.02	Data size	32bit	Data format		HEX		
	Modbus communication	3604, 3605	CANopen communication		0x2D02, 0x00		

	address		address	
PtP2.04	Data size	32bit	Data format	HEX
	Modbus communication address	3608, 3609	CANopen communication address	0x2D04, 0x00
PtP2.06	Data size	32bit	Data format	HEX
	Modbus communication address	3612, 3613	CANopen communication address	0x2D06, 0x00
PtP2.08	Data size	32bit	Data format	HEX
	Modbus communication address	3616, 3617	CANopen communication address	0x2D08, 0x00
PtP2.10	Data size	32bit	Data format	HEX
	Modbus communication address	3620, 3621	CANopen communication address	0x2D0A, 0x00
PtP2.12	Data size	32bit	Data format	HEX
	Modbus communication address	3624, 3625	CANopen communication address	0x2D0C, 0x00
PtP2.14	Data size	32bit	Data format	HEX
	Modbus communication address	3628, 3629	CANopen communication address	0x2D0E, 0x00
PtP2.16	Data size	32bit	Data format	HEX
	Modbus communication address	3632, 3633	CANopen communication address	0x2D10, 0x00
PtP2.18	Data size	32bit	Data format	HEX
	Modbus communication address	3636, 3637	CANopen communication address	0x2D12, 0x00
PtP2.20	Data size	32bit	Data format	HEX
	Modbus communication address	3640, 3641	CANopen communication address	0x2D14, 0x00
PtP2.22	Data size	32bit	Data format	HEX
	Modbus	3644, 3645	CANopen	0x2D16, 0x00

	communication address		communication address	
PtP2.24	Data size	32bit	Data format	HEX
	Modbus communication address	3648, 3649	CANopen communication address	0x2D18, 0x00
PtP2.26	Data size	32bit	Data format	HEX
	Modbus communication address	3652, 3653	CANopen communication address	0x2D1A, 0x00
PtP2.28	Data size	32bit	Data format	HEX
	Modbus communication address	3656, 3657	CANopen communication address	0x2D1C, 0x00
PtP2.30	Data size	32bit	Data format	HEX
	Modbus communication address	3660, 3661	CANopen communication address	0x2D1E, 0x00
PtP2.32	Data size	32bit	Data format	HEX
	Modbus communication address	3664, 3665	CANopen communication address	0x2D20, 0x00
PtP2.34	Data size	32bit	Data format	HEX
	Modbus communication address	3668, 3669	CANopen communication address	0x2D22, 0x00
PtP2.36	Data size	32bit	Data format	HEX
	Modbus communication address	3672, 3673	CANopen communication address	0x2D24, 0x00
PtP2.38	Data size	32bit	Data format	HEX
	Modbus communication address	3676, 3677	CANopen communication address	0x2D26, 0x00
PtP2.40	Data size	32bit	Data format	HEX
	Modbus communication address	3680, 3681	CANopen communication address	0x2D28, 0x00
PtP2.42	Data size	32bit	Data format	HEX

	Modbus communication address	3684, 3685	CANopen communication address	0x2D2A, 0x00
PtP2.44	Data size	32bit	Data format	HEX
	Modbus communication address	3688, 3689	CANopen communication address	0x2D2C, 0x00
PtP2.46	Data size	32bit	Data format	HEX
	Modbus communication address	3692, 3693	CANopen communication address	0x2D2E, 0x00
PtP2.48	Data size	32bit	Data format	HEX
	Modbus communication address	3696, 3697	CANopen communication address	0x2D30, 0x00
PtP2.50	Data size	32bit	Data format	HEX
	Modbus communication address	3700, 3701	CANopen communication address	0x2D32, 0x00
PtP2.52	Data size	32bit	Data format	HEX
	Modbus communication address	3704, 3705	CANopen communication address	0x2D34, 0x00
PtP2.54	Data size	32bit	Data format	HEX
	Modbus communication address	3708, 3709	CANopen communication address	0x2D36, 0x00

PtP2.01	Position of segment 100	Setting range	Default	Unit	Applicable mode		
		$-(2^{31}-1)-(2^{31}-1)$	0	reference unit	P	-	-
PtP2.03	Position of segment 101	Setting range	Default	Unit	Applicable mode		
		$-(2^{31}-1)-(2^{31}-1)$	0	reference unit	P	-	-
PtP2.05	Position of segment 102	Setting range	Default	Unit	Applicable mode		
		$-(2^{31}-1)-(2^{31}-1)$	0	reference	P	-	-

				unit			
PtP2.07	Position of segment 103	Setting range	Default	Unit	Applicable mode		
		$-(2^{31}-1)-(2^{31}-1)$	0	reference unit	P	-	-
PtP2.09	Position of segment 104	Setting range	Default	Unit	Applicable mode		
		$-(2^{31}-1)-(2^{31}-1)$	0	reference unit	P	-	-
PtP2.11	Position of segment 105	Setting range	Default	Unit	Applicable mode		
		$-(2^{31}-1)-(2^{31}-1)$	0	reference unit	P	-	-
PtP2.13	Position of segment 106	Setting range	Default	Unit	Applicable mode		
		$-(2^{31}-1)-(2^{31}-1)$	0	reference unit	P	-	-
PtP2.15	Position of segment 107	Setting range	Default	Unit	Applicable mode		
		$-(2^{31}-1)-(2^{31}-1)$	0	reference unit	P	-	-
PtP2.17	Position of segment 108	Setting range	Default	Unit	Applicable mode		
		$-(2^{31}-1)-(2^{31}-1)$	0	reference unit	P	-	-
PtP2.19	Position of segment 109	Setting range	Default	Unit	Applicable mode		
		$-(2^{31}-1)-(2^{31}-1)$	0	reference unit	P	-	-
PtP2.21	Position of segment 110	Setting range	Default	Unit	Applicable mode		
		$-(2^{31}-1)-(2^{31}-1)$	0	reference unit	P	-	-
PtP2.23	Position of segment 111	Setting range	Default	Unit	Applicable mode		
		$-(2^{31}-1)-(2^{31}-1)$	0	reference unit	P	-	-
PtP2.25	Position of segment 112	Setting range	Default	Unit	Applicable mode		

		$-(2^{31}-1)-(2^{31}-1)$	0	reference unit	P	-	-
PtP2.27	Position of segment 113	Setting range	Default	Unit	Applicable mode		
		$-(2^{31}-1)-(2^{31}-1)$	0	reference unit	P	-	-
PtP2.29	Position of segment 114	Setting range	Default	Unit	Applicable mode		
		$-(2^{31}-1)-(2^{31}-1)$	0	reference unit	P	-	-
PtP2.31	Position of segment 115	Setting range	Default	Unit	Applicable mode		
		$-(2^{31}-1)-(2^{31}-1)$	0	reference unit	P	-	-
PtP2.33	Position of segment 116	Setting range	Default	Unit	Applicable mode		
		$-(2^{31}-1)-(2^{31}-1)$	0	reference unit	P	-	-
PtP2.35	Position of segment 117	Setting range	Default	Unit	Applicable mode		
		$-(2^{31}-1)-(2^{31}-1)$	0	reference unit	P	-	-
PtP2.37	Position of segment 118	Setting range	Default	Unit	Applicable mode		
		$-(2^{31}-1)-(2^{31}-1)$	0	reference unit	P	-	-
PtP2.39	Position of segment 119	Setting range	Default	Unit	Applicable mode		
		$-(2^{31}-1)-(2^{31}-1)$	0	reference unit	P	-	-
PtP2.41	Position of segment 120	Setting range	Default	Unit	Applicable mode		
		$-(2^{31}-1)-(2^{31}-1)$	0	reference unit	P	-	-
PtP2.43	Position of segment 121	Setting range	Default	Unit	Applicable mode		
		$-(2^{31}-1)-(2^{31}-1)$	0	reference unit	P	-	-

PtP2.45	Position of segment 122	Setting range	Default	Unit	Applicable mode		
		$-(2^{31}-1)-(2^{31}-1)$	0	reference unit	P	-	-
PtP2.47	Position of segment 123	Setting range	Default	Unit	Applicable mode		
		$-(2^{31}-1)-(2^{31}-1)$	0	reference unit	P	-	-
PtP2.49	Position of segment 124	Setting range	Default	Unit	Applicable mode		
		$-(2^{31}-1)-(2^{31}-1)$	0	reference unit	P	-	-
PtP2.51	Position of segment 125	Setting range	Default	Unit	Applicable mode		
		$-(2^{31}-1)-(2^{31}-1)$	0	reference unit	P	-	-
PtP2.53	Position of segment 126	Setting range	Default	Unit	Applicable mode		
		$-(2^{31}-1)-(2^{31}-1)$	0	reference unit	P	-	-
PtP2.55	Position of segment 127	Setting range	Default	Unit	Applicable mode		
		$-(2^{31}-1)-(2^{31}-1)$	0	reference unit	P	-	-
<p>This group of parameters specify the positions of segment 100 to segment 127. The CMD attribute determines the command mode of this PTP position. P0.37 is inapplicable to this PTP position.</p>							
PtP2.01	Data size	32bit	Data format		DEC		
	Modbus communication address	3602, 3603	CANopen communication address		0x2D01, 0x00		
PtP2.03	Data size	32bit	Data format		DEC		
	Modbus communication address	3606, 3607	CANopen communication address		0x2D03, 0x00		
PtP2.05	Data size	32bit	Data format		DEC		
	Modbus communication address	3610, 3611	CANopen communication address		0x2D05, 0x00		



PtP2.07	Data size	32bit	Data format	DEC
	Modbus communication address	3614, 3615	CANopen communication address	0x2D07, 0x00
PtP2.09	Data size	32bit	Data format	DEC
	Modbus communication address	3618, 3619	CANopen communication address	0x2D09, 0x00
PtP2.11	Data size	32bit	Data format	DEC
	Modbus communication address	3622, 3623	CANopen communication address	0x2D0B, 0x00
PtP2.13	Data size	32bit	Data format	DEC
	Modbus communication address	3626, 3627	CANopen communication address	0x2D0D, 0x00
PtP2.15	Data size	32bit	Data format	DEC
	Modbus communication address	3630, 3631	CANopen communication address	0x2D0F, 0x00
PtP2.17	Data size	32bit	Data format	DEC
	Modbus communication address	3634, 3635	CANopen communication address	0x2D11, 0x00
PtP2.19	Data size	32bit	Data format	DEC
	Modbus communication address	3638, 3639	CANopen communication address	0x2D13, 0x00
PtP2.21	Data size	32bit	Data format	DEC
	Modbus communication address	3642, 3643	CANopen communication address	0x2D15, 0x00
PtP2.23	Data size	32bit	Data format	DEC
	Modbus communication address	3646, 3647	CANopen communication address	0x2D17, 0x00
PtP2.25	Data size	32bit	Data format	DEC
	Modbus communication	3650, 3651	CANopen communication	0x2D19, 0x00

	address		address	
PtP2.27	Data size	32bit	Data format	DEC
	Modbus communication address	3654, 3655	CANopen communication address	0x2D1B, 0x00
PtP2.29	Data size	32bit	Data format	DEC
	Modbus communication address	3658, 3659	CANopen communication address	0x2D1D, 0x00
PtP2.31	Data size	32bit	Data format	DEC
	Modbus communication address	3662, 3663	CANopen communication address	0x2D1F, 0x00
PtP2.33	Data size	32bit	Data format	DEC
	Modbus communication address	3666, 3667	CANopen communication address	0x2D21, 0x00
PtP2.35	Data size	32bit	Data format	DEC
	Modbus communication address	3670, 3671	CANopen communication address	0x2D23, 0x00
PtP2.37	Data size	32bit	Data format	DEC
	Modbus communication address	3674, 3675	CANopen communication address	0x2D25, 0x00
PtP2.39	Data size	32bit	Data format	DEC
	Modbus communication address	3678, 3679	CANopen communication address	0x2D27, 0x00
PtP2.41	Data size	32bit	Data format	DEC
	Modbus communication address	3682, 3683	CANopen communication address	0x2D29, 0x00
PtP2.43	Data size	32bit	Data format	DEC
	Modbus communication address	3686, 3687	CANopen communication address	0x2D2B, 0x00
PtP2.45	Data size	32bit	Data format	DEC
	Modbus	3690, 3691	CANopen	0x2D2D, 0x00

	communication address		communication address	
PtP2.47	Data size	32bit	Data format	DEC
	Modbus communication address	3694, 3695	CANopen communication address	0x2D2F, 0x00
PtP2.49	Data size	32bit	Data format	DEC
	Modbus communication address	3698, 3699	CANopen communication address	0x2D31, 0x00
PtP2.51	Data size	32bit	Data format	DEC
	Modbus communication address	3702, 3703	CANopen communication address	0x2D33, 0x00
PtP2.53	Data size	32bit	Data format	DEC
	Modbus communication address	3706, 3707	CANopen communication address	0x2D35, 0x00
PtP2.55	Data size	32bit	Data format	DEC
	Modbus communication address	3710, 3711	CANopen communication address	0x2D37, 0x00

9.9 State monitoring

9.9.1 User monitoring (Group R0 parameters)

R0.00	Motor rotation speed	Setting range	Precision	Unit
		-9999.9~9999.9	0.1	r/min
This parameter displays the actual speed of the servo motor.				
 Note: This parameter is processed with filtering when displaying.				
R0.00	Data size	32bit	Data format	DEC
	Modbus communication address	4000, 4001	CANopen communication address	0x3000, 0x00
R0.01	Speed command	Setting range	Precision	Unit
		-9999.9~9999.9	0.1	r/min
This parameter displays the current speed command of the servo motor.				
 Note: If the ACC/DEC time function is enabled, the command indicates the command that				

is executed after the ACC/DEC.				
R0.01	Data size	32bit	Data format	DEC
	Modbus communication address	4002, 4003	CANopen communication address	0x3001, 0x00
R0.02	Accumulated feedback pulses	Setting range -(263-1)-(263-1)	Precision 1	Unit pulse
This parameter accumulates and displays the feedback pulses (with signs) of the servo motor. The unit is the user unit.				
R0.02	Data size	64bit	Data format	DEC
	Modbus communication address	4004, 4005, 4006, 4007	CANopen communication address	0x3002, 0x00, 0x3002, 0x01
R0.03	Accumulated command pulses	Setting range -(263-1)-(263-1)	Precision 1	Unit pulse
This parameter accumulates and displays the position command pulses with signs. The unit is the user unit.				
R0.03	Data size	64bit	Data format	DEC
	Modbus communication address	4008, 4009, 4010, 4011	CANopen communication address	0x3003, 0x00, 0x3003, 0x01
R0.04	Residual pulses	Setting range -(231-1)-(231-1)	Precision 1	Unit pulse
This parameter displays the residual pulses with signs of the position deviation counter. The unit is the user unit.				
R0.04	Data size	32bit	Data format	DEC
	Modbus communication address	4012, 4013	CANopen communication address	0x3004, 0x00
R0.05	Hybrid control deviation	Setting range -(231-1)-(231-1)	Precision 1	Unit pulse
This parameter displays the tolerance with a sign between the encoder feedback position and linear encoder feedback position when the fully-closed loop function is enabled. The unit is the user unit.				
R0.05	Data size	32bit	Data format	DEC
	Modbus	4014, 4015	CANopen	0x3005, 0x00

	communication address		communication address	
--	-----------------------	--	-----------------------	--

R0.06	Current torque	Setting range	Precision	Unit
		-500.0-500.0	0.1	%

This parameter displays the current torque, which is expressed in percentage, assuming the servo motor rated torque is 100.0%.

R0.06	Data size	16bit	Data format	DEC
	Modbus communication address	4016, 4017	CANopen communication address	0x3006, 0x00

R0.07	Main circuit DC voltage	Setting range	Precision	Unit
		0.0-1000.0	0.1	V

This parameter displays the DC bus voltage of the main circuit power.

R0.07	Data size	16bit	Data format	DEC
	Modbus communication address	4018, 4019	CANopen communication address	0x3007, 0x00

R0.08	Control power voltage	Setting range	Precision	Unit
		0.0-1000.0	0.1	V

This parameter displays the DC bus voltage of the control circuit power.

R0.08	Data size	16bit	Data format	DEC
	Modbus communication address	4020, 4021	CANopen communication address	0x3008, 0x00

R0.09	Output voltage	Setting range	Precision	Unit
		0.0-1000.0	0.1	Vrms

This parameter displays the present output line voltage.

R0.09	Data size	16bit	Data format	DEC
	Modbus communication address	4022, 4023	CANopen communication address	0x3009, 0x00

R0.10	Output current	Setting range	Precision	Unit
		0.00-1000.00	0.01	Arms

This parameter displays the valid value of the present output line current.

R0.10	Data size	32bit	Data format	DEC
-------	-----------	-------	-------------	-----

	Modbus communication address	4024, 4025	CANopen communication address	0x300A, 0x00
R0.11	Drive temperature	Setting range	Precision	Unit
		-55.0–180.0	0.1	°C
This parameter displays the present temperature of the drive IGBT module.				
R0.11	Data size	16bit	Data format	DEC
	Modbus communication address	4026, 4027	CANopen communication address	0x300B, 0x00
R0.12	Torque limit	Setting range	Precision	Unit
		-500.0–500.0	0.1	%
This parameter displays the actual torque limit, which is expressed in percentage, assuming the servo motor rated torque is 100.0%.				
R0.12	Data size	16bit	Data format	DEC
	Modbus communication address	4028, 4029	CANopen communication address	0x300C, 0x00
R0.13	Encoder feedback value	Setting range	Precision	Unit
		0–(2 ³¹ -1)	1	pulse
This parameter displays the current feedback value of the encoder.				
R0.13	Data size	32bit	Data format	DEC
	Modbus communication address	4030, 4031	CANopen communication address	0x300D, 0x00
R0.14	Rotor position relative to Z pulse	Setting range	Precision	Unit
		0–(231-1)	1	pulse
This parameter displays the absolute mechanical position of the motor in one encoder rotation cycle. The unit is encoder resolution.				
R0.14	Data size	32bit	Data format	DEC
	Modbus communication address	4032, 4033	CANopen communication address	0x300E, 0x00
R0.15	Load inertia ratio	Setting range	Precision	Unit
		0–10000	1	%

This parameter displays the ratio of the load rotation inertia on the servo motor shaft to that on the servo motor.

R0.15	Data size	16bit	Data format	DEC
	Modbus communication address	4034, 4035	CANopen communication address	0x300F, 0x00

R0.16	Output power	Setting range	Precision	Unit
		-500.0-500.0	0.1	%

This parameter displays the current output mechanical power, which is expressed in percentage, assuming the servo motor rated power is 100%.

Note: A negative value indicates the motor is in power generation state.

R0.16	Data size	16bit	Data format	DEC
	Modbus communication address	4036, 4037	CANopen communication address	0x3010, 0x00

R0.17	Motor load ratio	Setting range	Precision	Unit
		0.0-500.0	0.1	%

This parameter displays the actual motor load ratio, which is expressed in percentage, assuming the servo motor rated power is 100%.

R0.17	Data size	16bit	Data format	DEC
	Modbus communication address	4038, 4039	CANopen communication address	0x3011, 0x00

R0.18	Numerator of actual electronic gear ratio	Setting range	Precision	Unit
		0-(231-1)	1	-

This parameter displays the numerator of the actual electronic gear ratio.

R0.18	Data size	32bit	Data format	DEC
	Modbus communication address	4040, 4041	CANopen communication address	0x3012, 0x00

R0.19	Denominator of actual electronic gear ratio	Setting range	Precision	Unit
		1-(231-1)	1	-

This parameter displays the denominator of actual electronic gear ratio.

R0.19	Data size	32bit	Data format	DEC
	Modbus	4042, 4043	CANopen	0x3013, 0x00

	communication address		communication address	
--	-----------------------	--	-----------------------	--

R0.20	Position command speed	Setting range	Precision	Unit
		-9999.9~9999.9	0.1	r/min

This parameter displays the speed corresponding to a position command.

R0.20	Data size	32bit	Data format	DEC
	Modbus communication address	4044, 4045	CANopen communication address	0x3014, 0x00

R0.21	Motor speed (filtering)	Setting range	Precision	Unit
		-9999.9~9999.9	0.1	r/min

This parameter displays the rotation speed that is used after filtering is executed for the servo motor.

R0.21	Data size	32bit	Data format	DEC
	Modbus communication address	4046, 4047	CANopen communication address	0x3015, 0x00

R0.22	PTP state	Setting range	Precision	Unit
		-1~4223	1	-

This parameter displays the status of PTP control. The value -1 indicates PTP control is not executed. Any value from 0 to 127 indicates the number of segment that is being executed. A segment number plus 4096 indicates the current segment has been executed.

R0.22	Data size	16bit	Data format	DEC
	Modbus communication address	4048, 4049	CANopen communication address	0x3016, 0x00

R0.23	Encoder absolute position feedback	Setting range	Precision	Unit
		-(231-1)~(231-1)	1	pulse

This parameter displays the encoder absolute position feedback. After absolute position clearing is executed, the setting of this parameter is 0.

R0.23	Data size	32bit	Data format	DEC
	Modbus communication address	4050, 4051	CANopen communication address	0x3017, 0x00

R0.24	Encoder EEPROM data state	Setting range	Precision	Unit										
		0-3	-	-										
<p>This parameter displays the EEPROM state of the absolute encoder. If motor parameter data is not found in EEPROM or incorrect, the system uses the internal motor parameters of the drive.</p> <table border="1" style="margin-left: auto; margin-right: auto;"> <thead> <tr> <th>Set value</th> <th>Meaning</th> </tr> </thead> <tbody> <tr> <td>[0]</td> <td>No EEPROM</td> </tr> <tr> <td>1</td> <td>No data found in the EEPROM</td> </tr> <tr> <td>2</td> <td>EEPROM data error</td> </tr> <tr> <td>3</td> <td>Data in the EEPROM is valid.</td> </tr> </tbody> </table>					Set value	Meaning	[0]	No EEPROM	1	No data found in the EEPROM	2	EEPROM data error	3	Data in the EEPROM is valid.
Set value	Meaning													
[0]	No EEPROM													
1	No data found in the EEPROM													
2	EEPROM data error													
3	Data in the EEPROM is valid.													
R0.24	Data size	16bit	Data format	DEC										
	Modbus communication address	4052, 4053	CANopen communication address	0x3018, 0x00										
R0.25	Turns of multi-turn encoder	Setting range	Precision	Unit										
		-32768-32767	1	-										
<p>This parameter displays the number of turns of the multi-turn encoder.</p>														
R0.25	Data size	16bit	Data format	DEC										
	Modbus communication address	4054, 4055	CANopen communication address	0x3019, 0x00										
R0.26	Available encoder type	Setting range	Precision	Unit										
		0-6	-	-										
<p>This parameter displays the encoder type supported by hardware circuit.</p> <table border="1" style="margin-left: auto; margin-right: auto;"> <thead> <tr> <th>Set value</th> <th>Meaning</th> </tr> </thead> <tbody> <tr> <td>[3]</td> <td>Photoelectric encoder</td> </tr> <tr> <td>5</td> <td>Rotary transformer</td> </tr> <tr> <td>Other</td> <td>(Reserved)</td> </tr> </tbody> </table>					Set value	Meaning	[3]	Photoelectric encoder	5	Rotary transformer	Other	(Reserved)		
Set value	Meaning													
[3]	Photoelectric encoder													
5	Rotary transformer													
Other	(Reserved)													
R0.26	Data size	16bit	Data format	DEC										
	Modbus communication address	4056, 4057	CANopen communication address	0x301A, 0x00										

R0.27	EtherCAT clock synchronous correction state	Setting range	Precision	Unit
		0-1	-	-

This parameter displays whether the drive internal clock has been synchronized with DC Sync0 in DC mode which is used for EtherCAT communication synchronization.

Display	Meaning
[0]	Not synchronized
1	Synchronized

R0.27	Data size	16bit	Data format	DEC
	Modbus communication address	4058, 4059	CANopen communication address	0x301B, 0x00

R0.28	State of CANopen state machine	Setting range	Precision	Unit
		0-18	-	-

This parameter displays the current state of the internal CANopen state machine when CAN is used for communication or that of the CANopen over EtherCAT (CoE) state machine when EtherCAT is used for communication.

Display	Communication mode	Meaning
[0]	-	Invalid
1	CAN	Init
2		Pre-Op
5		Stop
8		Op (that is, Operational)
11	EtherCAT	Init
12		Pre-Op
14		Safe-Op
18		Op (that is, Operational)

R0.28	Data size	16bit	Data format	DEC
	Modbus communication address	4060, 4061	CANopen communication address	0x301C, 0x00

R0.29	PROFIBUS-DP slave node number	Setting range	Precision	Unit
		0-99	-	-

This parameter displays the currently obtained slave node number on the PROFIBUS-DP communication card, corresponding to the setting of the rotary switch.

R0.29	Data size	16bit	Data format	DEC
	Modbus communication address	4062, 4063	CANopen communication address	0x301D, 0x00

R0.30	System state	Setting range	Precision	Unit
		0-8	-	-

This parameter displays the system state of the drive.

Set value	Meaning
[0]	Initialization
1	Main power supply power-on
2	The electrical angle is not determined
3	Ready
4	Bootstrapped
5	Run
6	Fault response
7	Fault
8	STO-In

R0.30	Data size	16bit	Data format	DEC
	Modbus communication address	4064, 4065	CANopen communication address	0x301E, 0x00

R0.31	IGBT state	Setting range	Precision	Unit
		0-1	-	-

This parameter displays the IGBT state.

Set value	Meaning
[0]	Closed
1	Open

R0.31	Data size	16bit	Data format	DEC
	Modbus communication address	4066, 4067	CANopen communication address	0x301F, 0x00

R0.32	Current mode	Setting range	Precision	Unit
		0-2	-	-
This parameter displays the control mode that the drive uses currently.				
		Set value	Meaning	
		[0]	Position mode	
		1	Speed mode	
		2	Torque mode	
R0.32	Data size	16bit	Data format	DEC
	Modbus communication address	4068, 4069	CANopen communication address	0x3020, 0x00
R0.33	Power-on time	Setting range	Precision	Unit
		0-(2 ³¹ -1)	1	s
This parameter displays the total power-on time used by the drive.				
R0.33	Data size	32bit	Data format	DEC
	Modbus communication address	4070, 4071	CANopen communication address	0x3021, 0x00
R0.34	Running time	Symbol	Precision	Unit
		0-(2 ³¹ -1)	1	s
This parameter displays the time used by the drive to enable the servo.				
R0.34	Data size	32bit	Data format	DEC
	Modbus communication address	4072, 4073	CANopen communication address	0x3022, 0x00
R0.35	DSP software version	Setting range	Precision	Unit
		0.00-10.00	0.01	-
This parameter displays the DSP version number.				
R0.35	Data size	16bit	Data format	DEC
	Modbus communication address	4074, 4075	CANopen communication address	0x3023, 0x00
R0.36	FPGA software version	Setting range	Precision	Unit
		0.00-10.00	0.01	-

This parameter displays the FPGA version number.

R0.36	Data size	16bit	Data format	DEC
	Modbus communication address	4076, 4077	CANopen communication address	0x3024, 0x00

R0.37	Communication card software version	Setting range	Precision	Unit
		0.00-10.00	0.01	-

This parameter displays the version number of the present communication card software.

R0.37	Data size	16bit	Data format	DEC
	Modbus communication address	4078, 4079	CANopen communication address	0x3025, 0x00

R0.38	Drive SN 1	Setting range	Precision	Unit
		0-65535	1	-

This parameter displays serial number 1 of the drive.

R0.38	Data size	16bit	Data format	DEC
	Modbus communication address	4080, 4081	CANopen communication address	0x3026, 0x00

R0.39	Drive SN 2	Setting range	Precision	Unit
		0-65535	1	-

This parameter displays serial number 2 of the drive.

R0.39	Data size	16bit	Data format	DEC
	Modbus communication address	4082, 4083	CANopen communication address	0x3027, 0x00

R0.40	Drive SN 3	Setting range	Precision	Unit
		0-65535	1	-

This parameter displays serial number 3 of the drive.

R0.40	Data size	16bit	Data format	DEC
	Modbus communication address	4084, 4085	CANopen communication address	0x3028, 0x00

R0.41	Drive SN 4	Setting range	Precision	Unit
-------	------------	---------------	-----------	------

		0-65535	1	-
This parameter displays serial number 4 of the drive.				
R0.41	Data size	16bit	Data format	DEC
	Modbus communication address	4086, 4087	CANopen communication address	0x3029, 0x00

R0.42	Drive SN 5	Setting range	Precision	Unit
		0-65535	1	-
This parameter displays serial number 5 of the drive.				
R0.42	Data size	16bit	Data format	DEC
	Modbus communication address	4088, 4089	CANopen communication address	0x302A, 0x00

R0.43	Drive SN 6	Setting range	Precision	Unit
		0-65535	1	-
This parameter displays serial number 6 of the drive.				
R0.43	Data size	16bit	Data format	DEC
	Modbus communication address	4090, 4091	CANopen communication address	0x302B, 0x00

R0.44	Absolute position of linear encoder (second encoder) in single circle	Setting range	Precision	Unit
		0-(2 ³¹ -1)	1	pulse
This parameter displays the feedback value of absolute position of linear encoder (second encoder) in single circle.				
R0.44	Data size	32bit	Data format	DEC
	Modbus communication address	4092, 4093	CANopen communication address	0x302C, 0x00

R0.45	Speed feedback of second encoder	Setting range	Precision	Unit
		-9999.9-9999.9	0.1	r/min
This parameter displays the actual speed of the servo motor.				
R0.45	Data size	32bit	Data format	DEC
	Modbus	4094, 4095	CANopen	0x302D, 0x00

	communication address		communication address	
R0.46	Detected speed of speed observer	Setting range	Precision	Unit
		-9999.9~9999.9	0.1	r/min
This parameter displays the detected speed of the speed observer.				
R0.46	Data size	32bit	Data format	DEC
	Modbus communication address	4096, 4097	CANopen communication address	0x302E, 0x00
R0.47	Feedback speed of speed observer	Setting range	Precision	Unit
		-9999.9~9999.9	0.1	r/min
This parameter displays the feedback speed of the speed observer.				
R0.47	Data size	32bit	Data format	DEC
	Modbus communication address	4098, 4099	CANopen communication address	0x302F, 0x00
R0.48	Observing disturbance torque of disturbance observer	Setting range	Precision	Unit
		-1000.0~1000.0	0.1	%
This parameter displays the compensation torque of the disturbance observer.				
R0.48	Data size	32bit	Data format	DEC
	Modbus communication address	4100, 4101	CANopen communication address	0x3030, 0x00
R0.49	Compensation value of fully-closed-loop vibration suppressor	Setting range	Precision	Unit
		-9999.9~9999.9	0.1	r/min
This parameter displays the compensation value of the fully-closed loop vibration suppressor.				
R0.49	Data size	32bit	Data format	DEC
	Modbus communication address	4102, 4103	CANopen communication address	0x3031, 0x00

R0.51	Observe load inertia ratio in real time	Setting range	Precision	Unit
		0-10000	1	%
This parameter displays the load inertia ratio observed in real time.				
R0.51	Data size	16bit	Data format	DEC
	Modbus communication address	4106, 4107	CANopen communication address	0x3033, 0x00
R0.52	Accumulated linear encoder (second encoder) position feedback (32-bit)	Setting range	Precision	Unit
		$-(2^{31}-1)-(2^{31}-1)$	1	pulse
This parameter accumulates and displays the 32-bit absolute position feedback from the linear encoder (second encoder). It can be read quickly. If the data range exceeds 32 bits, it is replaced by R0.57.				
R0.52	Data size	32bit	Data format	DEC
	Modbus communication address	4108, 4109	CANopen communication address	0x3034, 0x00
R0.53	Gantry synchronization position deviation	Setting range	Precision	Unit
		$-(2^{31}-1)-(2^{31}-1)$	1	reference unit
This parameter displays the gantry synchronization position deviation.				
R0.53	Data size	32bit	Data format	DEC
	Modbus communication address	4110, 4111	CANopen communication address	0x3035, 0x00
R0.54	Linear encoder (second encoder) position feedback value	Setting range	Precision	Unit
		$0-(2^{31}-1)$	1	pulse
This parameter displays the feedback position of the linear encoder (second encoder).				
R0.54	Data size	32bit	Data format	DEC
	Modbus communication address	4112, 4113	CANopen communication address	0x3036, 0x00

R0.55	Encoder turn deviation after multi-turn position cleared	Setting range	Precision	Unit
		$-(2^{31}-1)-(2^{31}-1)$	1	-

This parameter displays the encoder turn deviation after multi-turn positions are cleared.

R0.55	Data size	32bit	Data format	DEC
	Modbus communication address	4114, 4115	CANopen communication address	0x3037, 0x00

R0.56	Encoder feedback deviation after multi-turn position cleared	Setting range	Precision	Unit
		$-(2^{31}-1)-(2^{31}-1)$	1	pulse

This parameter displays the encoder feedback deviation after multi-turn positions are cleared.

R0.56	Data size	32bit	Data format	DEC
	Modbus communication address	4116, 4117	CANopen communication address	0x3038, 0x00

R0.57	Accumulated linear encoder (second encoder) position feedback (64-bit)	Setting range	Precision	Unit
		$-(2^{63}-1)-(2^{63}-1)$	1	pulse

This parameter displays the accumulated linear encoder (second encoder) position feedback, 64 bits.

R0.57	Data size	64bit	Data format	DEC
	Modbus communication address	4118, 4119, 4120, 4121	CANopen communication address	0x3039, 0x00 0x3039, 0x01

R0.58	Position inside the single-turn of the disk	Setting range	Precision	Unit
		$-(2^{31}-1)-(2^{31}-1)$	1	pulse

This parameter displays the position inside the single-turn of the disk according to the set value of P5.70 [Disk single-turn resolution].

R0.58	Data size	32bit	Data format	DEC
	Modbus communication address	4122, 4123	CANopen communication address	0x303A, 0x00

		address			address		
R0.60	Motor temperature	Setting range	Precision	Unit			
		-55-200	0	°C			
This parameter displays the current temperature of the motor with temperature resistor KTY84-130. Temperature is sampled only when P4.45 is not zero.							
R0.60	Data size	32bit	Data format	DEC			
	Modbus communication address	4126, 4127	CANopen communication address	0x303C, 0x00			
R0.61	Load ratio of main interrupt task	Setting range	Precision	Unit			
		0.00-100.00	2	%			
This parameter displays the load ratio of the drive main interrupt task.							
R0.61	Data size	32bit	Data format	DEC			
	Modbus communication address	4128, 4129	CANopen communication address	0x303D, 0x00			
R0.62	Load ratio of 1ms task	Setting range	Precision	Unit			
		0.00-100.00	2	%			
This parameter displays the load ratio of the drive 1ms task.							
R0.62	Data size	32bit	Data format	DEC			
	Modbus communication address	4130, 4131	CANopen communication address	0x303E, 0x00			
R0.64	CIA402 control word	Setting range	Precision	Unit			
		0-FFFF	0	-			
This parameter displays the CIA402 control word.							
R0.64	Data size	16bit	Data format	HEX			
	Modbus communication address	4134, 4135	CANopen communication address	0x3040, 0x00			
R0.65	CIA402 status word	Setting range	Precision	Unit			
		0-FFFF	0	-			
This parameter displays the CIA402 status word.							
R0.65	Data size	16bit	Data format	HEX			
	Modbus	4136, 4137	CANopen	0x3041, 0x00			

	communication address		communication address	
R0.66	CIA402 control mode	Setting range	Precision	Unit
		0-65535	0	-
This parameter displays the CIA402 control mode.				
R0.66	Data size	16bit	Data format	DEC
	Modbus communication address	4138, 4139	CANopen communication address	0x3042, 0x00
R0.67	Network fault counting 0	Setting range	Precision	Unit
		0-65535	0	-
This parameter displays the fault count value 0 received and forwarded by EtherCAT network port.				
R0.67	Data size	32bit	Data format	DEC
	Modbus communication address	4140, 4141	CANopen communication address	0x3043, 0x00
R0.68	Network fault counting 1	Setting range	Precision	Unit
		0-65535	0	-
This parameter displays the fault count value 1 received and forwarded by EtherCAT network port.				
R0.68	Data size	32bit	Data format	DEC
	Modbus communication address	4142, 4143	CANopen communication address	0x3044, 0x00
R0.69	Rotary load single-turn position (Encoder unit)	Setting range	Precision	Unit
		-2147483647- 2147483647	0	Encoder unit
This parameter displays the rotary load single-turn position (encoder unit).				
R0.69	Data size	32bit	Data format	DEC
	Modbus communication address	4144, 4145	CANopen communication address	0x3045, 0x00

R0.70	Rotary load single-turn position (User unit)	Setting range	Precision	Unit
		-2147483647~ 2147483647	0	User unit
This parameter displays the rotary load single-turn position (user unit).				
R0.70	Data size	32bit	Data format	DEC
	Modbus communication address	4146, 4147	CANopen communication address	0x3046, 0x00
R0.71	Angle value of rotary load side	Setting range	Precision	Unit
		0~360.00	2	-
This parameter displays the angle value of rotary load side.				
R0.71	Data size	32bit	Data format	DEC
	Modbus communication address	4148, 4149	CANopen communication address	0x3047, 0x00
R0.72	EtherCAT synchronization offset time	Setting range	Precision	Unit
		0~30000	0	us
This parameter specifies the EtherCAT synchronization offset time.				
R0.72	Data size	32bit	Data format	DEC
	Modbus communication address	4150, 4151	CANopen communication address	0x3048, 0x00
R0.73	Positioning compensation state	Setting range	Precision	Unit
		0~3	-	-
This parameter specifies the positioning compensation state.				
		Set value	Meaning	
		[0]	Disable	
		1	Wait for homing	
		2	Homing completed	
		3	Enable	
R0.73	Data size	16bit	Data format	DEC
	Modbus communication address	4152, 4153	CANopen communication address	0x3049, 0x00

	address		address	
R0.99	Fault code	Setting range	Precision	Unit
		-32768~32767	1	-
This parameter specifies the fault code, in which the thousands and hundreds digits are the main fault code and the tens and ones digits are the sub fault code.				
R0.99	Data size	16bit	Data format	DEC
	Modbus communication address	4198, 4199	CANopen communication address	0x3063, 0x00

9.9.2 I/O monitoring (Group R1 parameters)

R1.00	Digital input state	Setting range	Precision	Unit																				
		0x000~0x3FF	-	-																				
R1.01	Digital output state	Setting range	Precision	Unit																				
		0x00~0x3F	-	-																				
This value is arranged in digital order and indicates the hex number of digital terminal state. When a terminal is in ON state, its corresponding bit is 1. When a terminal is in OFF state, its corresponding bit is 0. Then, this binary number is converted into a hexadecimal number. For example, 000000001011 is denoted as 0x00B.																								
The digital input state is denoted as 3-digit hexadecimal number. The arrangement sequence of the digital input is listed as below: (the digits not listed are filled with 0).																								
<table border="1" style="margin-left: auto; margin-right: auto;"> <tr> <td>Bit9</td><td>Bit8</td><td>Bit7</td><td>Bit6</td><td>Bit5</td><td>Bit4</td><td>Bit3</td><td>Bit2</td><td>Bit1</td><td>Bit0</td> </tr> <tr> <td>SI10</td><td>SI9</td><td>SI8</td><td>SI7</td><td>SI6</td><td>SI5</td><td>SI4</td><td>SI3</td><td>SI2</td><td>SI1</td> </tr> </table>					Bit9	Bit8	Bit7	Bit6	Bit5	Bit4	Bit3	Bit2	Bit1	Bit0	SI10	SI9	SI8	SI7	SI6	SI5	SI4	SI3	SI2	SI1
Bit9	Bit8	Bit7	Bit6	Bit5	Bit4	Bit3	Bit2	Bit1	Bit0															
SI10	SI9	SI8	SI7	SI6	SI5	SI4	SI3	SI2	SI1															
The digital output state is denoted as 2-digit hexadecimal number. The arrangement sequence of the digital output is listed as below: (the digits not listed are filled with 0)																								
<table border="1" style="margin-left: auto; margin-right: auto;"> <tr> <td>Bit5</td><td>Bit4</td><td>Bit3</td><td>Bit2</td><td>Bit1</td><td>Bit0</td> </tr> <tr> <td>SO6</td><td>SO5</td><td>SO4</td><td>SO3</td><td>SO2</td><td>SO1</td> </tr> </table>					Bit5	Bit4	Bit3	Bit2	Bit1	Bit0	SO6	SO5	SO4	SO3	SO2	SO1								
Bit5	Bit4	Bit3	Bit2	Bit1	Bit0																			
SO6	SO5	SO4	SO3	SO2	SO1																			
R1.00	Data size	16bit	Data format	HEX																				
	Modbus communication address	4200, 4201	CANopen communication address	0x3100, 0x00																				
R1.01	Data size	16bit	Data format	HEX																				
	Modbus communication address	4202, 4203	CANopen communication address	0x3101, 0x00																				

R1.02	Original voltage of analog input 1	Setting range	Precision	Unit
		-10.000-10.000	0.001	V
This parameter displays the unprocessed voltage of the analog input channel 1.				
R1.02	Data size	32bit	Data format	DEC
	Modbus communication address	4204, 4205	CANopen communication address	0x3102, 0x00
R1.03	Original voltage of analog input 2	Setting range	Precision	Unit
		-10.000-10.000	0.001	V
This parameter displays the unprocessed voltage of the analog input channel 2.				
R1.03	Data size	32bit	Data format	DEC
	Modbus communication address	4206, 4207	CANopen communication address	0x3103, 0x00
R1.04	Original voltage of analog input 3	Setting range	Precision	Unit
		-10.000-10.000	0.001	V
This parameter displays the unprocessed voltage of the analog input channel 3.				
R1.04	Data size	32bit	Data format	DEC
	Modbus communication address	4208, 4209	CANopen communication address	0x3104, 0x00
R1.05	Voltage of analog input 1	Setting range	Precision	Unit
		-10.000-10.000	0.001	V
This parameter displays the corrected voltage of the analog input channel 1.				
R1.05	Data size	32bit	Data format	DEC
	Modbus communication address	4210, 4211	CANopen communication address	0x3105, 0x00
R1.06	Voltage of analog input 2	Setting range	Precision	Unit
		-10.000-10.000	0.001	V
This parameter displays the corrected voltage of the analog input channel 2.				
R1.06	Data size	32bit	Data format	DEC
	Modbus communication address	4212, 4213	CANopen communication address	0x3106, 0x00

R1.07	Voltage of analog input 3	Setting range	Precision	Unit
		-10.000-10.000	0.001	V
This parameter displays the corrected voltage of the analog input channel 3.				
R1.07	Data size	32bit	Data format	DEC
	Modbus communication address	4214, 4215	CANopen communication address	0x3107, 0x00
R1.08	Voltage of analog output 1	Setting range	Precision	Unit
		-10.000-10.000	0.001	V
This parameter displays the output voltage value after offset treatment of analog output channel 1.				
R1.08	Data size	32bit	Data format	DEC
	Modbus communication address	4216, 4217	CANopen communication address	0x3108, 0x00
R1.09	Voltage of analog output 2	Setting range	Precision	Unit
		-10.000-10.000	0.001	V
This parameter displays the output voltage value after offset treatment of analog output channel 2.				
R1.09	Data size	32bit	Data format	DEC
	Modbus communication address	4218, 4219	CANopen communication address	0x3109, 0x00
R1.11	Accumulated input pulses	Setting range	Precision	Unit
		$-(2^{31}-1)-(2^{31}-1)$	1	reference unit
This parameter accumulates and displays the number of pulses that are received from the external pulse input.				
R1.11	Data size	32bit	Data format	DEC
	Modbus communication address	4222, 4223	CANopen communication address	0x310B, 0x00
R1.12	Pulse position command	Setting range	Precision	Unit
		$-(2^{31}-1)-(2^{31}-1)$	1	reference unit
This parameter displays the position command value in each pulse input detection cycle (0.125ms by default).				

R1.12	Data size	32bit	Data format	DEC
	Modbus communication address	4224, 4225	CANopen communication address	0x310C, 0x00

R1.13	Pulse speed command	Setting range	Precision	Unit
		-10000.0–10000.0	0.1	r/min

This parameter displays the speed command corresponding to the pulse position command.

R1.13	Data size	32bit	Data format	DEC
	Modbus communication address	4226, 4227	CANopen communication address	0x310D, 0x00

R1.14	Analog compensation speed	Setting range	Precision	Unit
		-10000.0–10000.0	0.1	r/min

This parameter displays the analog compensation speed.

R1.14	Data size	32bit	Data format	DEC
	Modbus communication address	4228, 4229	CANopen communication address	0x310E, 0x00

R1.15	Analog compensation torque	Setting range	Precision	Unit
		-1000.0–1000.0	0.1	%

This parameter displays the analog compensation torque.

R1.15	Data size	32bit	Data format	DEC
	Modbus communication address	4230, 4231	CANopen communication address	0x310F, 0x00

R1.16	Captured value of the first encoder in single circle	Setting range	Precision	Unit
		-214748364–214748364	0	pulse

This parameter displays the encoder value captured through DI input.

R1.16	Data size	32bit	Data format	DEC
	Modbus communication address	4232, 4233	CANopen communication address	0x3110, 0x00

R1.17	Position feedback	Setting range	Precision	Unit
-------	-------------------	----------------------	------------------	-------------

	captured value of the first encoder	-214748364– 214748364	0	pulse
--	-------------------------------------	--------------------------	---	-------

This parameter displays the accumulated value of position (pulse) feedback.

Note: The unit is the encoder unit.

R1.17	Data size	64bit	Data format	DEC
	Modbus communication address	4234, 4235, 4236, 4237	CANopen communication address	0x3111, 0x00

R1.18	Captured value of the second encoder in single circle	Setting range	Precision	Unit
		-214748364– 214748364	0	pulse

This parameter displays the encoder value captured through DI input.

R1.18	Data size	32bit	Data format	DEC
	Modbus communication address	4238, 4239	CANopen communication address	0x3112, 0x00

R1.19	Position feedback captured value of the second encoder	Setting range	Precision	Unit
		-214748364– 214748364	0	pulse

This parameter displays the accumulated value of position (pulse) feedback.

Note: The unit is the encoder unit.

R1.19	Data size	64bit	Data format	DEC
	Modbus communication address	4240, 4241, 4242, 4243	CANopen communication address	0x3113, 0x00

R1.20	Digital output function state	Setting range	Precision	Unit
		0–80000000	0	-

This parameter displays the current state of each digital output function.

R1.20	Data size	32bit	Data format	HEX
	Modbus communication address	4244, 4245	CANopen communication address	0x3114, 0x00

9.9.3 Fault recording (Group R3 parameters)

R3.00	Fault code record	Setting range	Precision	Unit
		-	-	-
This parameter displays the code of the currently-read fault record. It contains the information on the last fault by default.				
R3.01	Power-on time when fault occurs	Setting range	Precision	Unit
		$0-(2^{31}-1)$	1	h
This parameter displays the power-on time when a fault occurs.				
R3.02	Running time when fault occurs	Setting range	Precision	Unit
		$0-(2^{31}-1)$	1	h
This parameter displays the running time when a fault occurs.				
R3.03	Motor speed when fault occurs	Setting range	Precision	Unit
		-20000-20000	1	r/min
This parameter displays the motor speed when a fault occurs.				
R3.04	Speed command when fault occurs	Setting range	Precision	Unit
		-20000-20000	1	r/min
This parameter displays the speed command when a fault occurs.				
R3.05	Feedback pulse accumulation when fault occurs	Setting range	Precision	Unit
		$-(263-1)-(263-1)$	1	reference unit
This parameter displays the feedback pulse accumulation when a fault occurs.				
R3.06	Command pulse accumulation when fault occurs	Setting range	Precision	Unit
		$-(263-1)-(263-1)$	1	reference unit
This parameter displays the command pulse accumulation when a fault occurs.				
R3.07	Residual pulses when fault occurs	Setting range	Precision	Unit
		$-(231-1)-(231-1)$	1	reference unit
This parameter displays the residual pulses when a fault occurs.				
R3.08	Current torque when fault occurs	Setting range	Precision	Unit
		-500.0-500.0	0.1	%
This parameter displays the torque output when a fault occurs.				
R3.09	Main circuit DC voltage	Setting range	Precision	Unit
		0.0-1000.0	0.1	V

	when fault occurs			
This parameter displays the main circuit DC voltage when a fault occurs.				
R3.10	Output voltage when fault occurs	Setting range 0.0–1000.0	Precision 0.1	Unit Vrms
This parameter displays the valid value of the output line voltage when a fault occurs.				
R3.11	Output current when fault occurs	Setting range 0.00–1000.00	Precision 0.01	Unit Arms
This parameter displays the valid value of the output line current when a fault occurs.				
R3.20	Last fault code	Setting range -	Precision -	Unit -
This parameter displays the fault code of the last fault.				
R3.21	2nd-last fault code	Setting range -	Precision -	Unit -
This parameter displays the fault code of the 2nd-last fault.				
R3.22	3rd-last fault code	Setting range -	Precision -	Unit -
This parameter displays the fault code of the 3rd-last fault.				
R3.23	4th-last fault code	Setting range -	Precision -	Unit -
This parameter displays the fault code of the 4th-last fault.				
R3.24	5th-last fault code	Setting range -	Precision -	Unit -
This parameter displays the fault code of the 5th-last fault.				
R3.25	6th-last fault code	Setting range -	Precision -	Unit -
This parameter displays the fault code of the 6th-last fault.				
R3.26	7th-last fault code	Setting range -	Precision -	Unit -
This parameter displays the fault code of the 7th-last fault.				
R3.27	8th-last fault code	Setting range -	Precision -	Unit -
This parameter displays the fault code of the 8th-last fault.				
R3.28	9th-last fault code	Setting range -	Precision -	Unit -

		-	-	-
This parameter displays the fault code of the 9th-last fault.				
R3.29	10th-last fault code	Setting range	Precision	Unit
		-	-	-
This parameter displays the fault code of the 10th-last fault.				

10 Fault handling

10.1 Fault codes

A fault code is displayed in the format of ErXX-X, in which XX indicates the main code and X indicates the sub code. For example, in **Er01-0**, 01 indicates the main code and 0 indicates the sub code. Other codes are displayed in the similar way. (“✓” indicates that this function is valid, and “-” indicates that this function is invalid.)

Fault code	Name	Attribute		
		History record	Can be cleared	Disable
Er01-0	IGBT fault	✓	-	✓
Er01-1	Braking pipe fault (7.5kW and above models)	✓	-	✓
Er01-2	U-phase IGBT fault	✓	-	✓
Er01-3	V-phase IGBT fault	✓	-	✓
Er01-4	W-phase IGBT fault	✓	-	✓
Er01-5	IPM fault	✓	-	✓
Er02-0	Encoder fault–Encoder disconnection	✓	-	✓
Er02-1	Encoder fault–Encoder feedback deviation too large	✓	-	✓
Er02-2	Encoder fault–odd/even check error	✓	-	✓
Er02-3	Encoder fault–CRC check error	✓	-	✓
Er02-4	Encoder fault–Frame error	✓	-	✓
Er02-5	Encoder fault–Short frame error	✓	-	✓
Er02-6	Encoder fault–Encoder communication timeout	✓	-	✓
Er02-7	Encoder fault–Encoder multi-turn error	✓	-	✓
Er02-8	Encoder fault–Encoder battery low-voltage alarm	-	-	-
Er02-9	Encoder fault–Encoder battery undervoltage fault	-	-	✓
Er02-a	Encoder fault–Encoder overheating	✓	-	✓
Er02-b	Encoder fault–Encoder EEPROM writing error	✓	-	✓
Er02-c	Encoder fault–No data in encoder EEPROM	-	-	✓
Er02-d	Encoder fault– Encoder EEPROM data	-	-	✓

Fault code	Name	Attribute		
		History record	Can be cleared	Disable
	check error			
Er02-e	Encoder fault–Encoder identification error	-	-	✓
Er02-f	Encoder fault–Failed to write the encoder offset angle	-	-	✓
Er03-0	Current sensor fault–Phase-U current sensor fault	✓	-	✓
Er03-1	Current sensor fault–Phase-V current sensor fault	✓	-	✓
Er03-2	Current sensor fault–Phase-W current sensor fault	✓	-	✓
Er04-0	System initialization fault	-	-	✓
Er04-1	Motor code initialization check failed	✓	✓	✓
Er05-0	Setting fault–Motor model not exist	✓	-	✓
Er05-1	Setting fault–Motor model not exist	✓	-	✓
Er05-2	Setting fault–Motor and drive model not match	✓	-	✓
Er05-3	Setting fault–Incorrect software limits	✓	✓	✓
Er05-4	Setting fault–Incorrect homing mode	✓	✓	✓
Er05-5	Setting fault–PTP-control travel overflow	✓	✓	✓
Er05-6	Setting fault–Power module setting error	✓	✓	✓
Er06-0	Brake fault	✓	✓	✓
Er07-0	Regenerative discharge overload fault	✓	✓	✓
Er08-0	AI overvoltage fault–AI 1	✓	✓	✓
Er08-1	AI overvoltage fault–AI 2	✓	✓	✓
Er08-2	AI overvoltage fault–analog input 3	✓	✓	✓
Er09-0	EEPROM fault–Read/write error	-	-	✓
Er09-1	EEPROM fault–Data check error	-	-	✓
Er10-0	Hardware fault–FPGA fault	✓	-	✓
Er10-1	Hardware fault– Communication card fault	✓	✓	✓
Er10-2	Hardware fault–To-ground short circuit fault	✓	✓	✓
Er10-3	Hardware fault–External input fault	✓	✓	✓
Er10-4	Hardware fault–Emergency stop fault	✓	✓	✓
Er10-5	Hardware fault–485 communication fault	✓	✓	✓
Er10-6	Hardware fault–AC power phase loss	✓	✓	✓

Fault code	Name	Attribute		
		History record	Can be cleared	Disable
Er10-7	Hardware fault–Fan fault	✓	✓	✓
Er10-8	Hardware fault–Regenerative transistor fault	✓	✓	✓
Er10-9	Hardware fault–STO phase loss	✓	✓	✓
Er10-a	Hardware fault–STO DPIN1 fault	✓	✓	✓
Er10-b	Hardware fault–STO DPIN2 fault	✓	✓	✓
Er10-e	Hardware fault–STO terminal fault	-	✓	✓
Er11-0	Software fault–Motor control task re-entry	✓	-	✓
Er11-1	Software fault–Periodic task re-entry	✓	-	✓
Er11-2	Software fault–Illegal operation	✓	-	✓
Er12-0	I/O fault–Duplicate DI assignment	✓	✓	✓
Er12-1	I/O fault–Duplicate AI assignment	✓	✓	✓
Er12-2	I/O fault–Pulse input frequency too high	✓	✓	✓
Er13-0	Main circuit overvoltage fault	✓	✓	✓
Er13-1	Main circuit undervoltage fault	-	✓	✓
Er14-0	Control power undervoltage fault	-	✓	✓
Er17-0	Drive overload fault	✓	-	✓
Er17-1	Drive overload fault 2	✓	-	✓
Er18-0	Motor overload fault	✓	✓	✓
Er18-1	Motor overtemperature fault	✓	✓	-
Er18-2	Motor three-phase loss fault	✓	-	✓
Er18-4	Motor U-phase loss fault	✓	-	✓
Er18-5	Motor V-phase loss fault	✓	-	✓
Er18-6	Motor W-phase loss fault	✓	-	✓
Er18-7	Motor temperature detection disconnection fault	✓	✓	✓
Er19-0	Speed fault–Overspeed fault	✓	✓	✓
Er19-1	Speed fault–FWD overspeed fault	✓	✓	✓
Er19-2	Speed fault–REV overspeed fault	✓	✓	✓
Er19-3	Speed fault–Incorrect overspeed parameter \square setting	✓	✓	✓
Er19-4	Speed fault–Out-of-control fault	✓	✓	✓
Er20-0	Speed out-of-tolerance fault	✓	✓	✓
Er21-0	Position overtravel - FWD overtravel	-	✓	-

Fault code	Name	Attribute		
		History record	Can be cleared	Disable
Er21-1	Position overtravel - REV overtravel	-	✓	-
Er22-0	Position out-of-tolerance fault	✓	✓	✓
Er22-1	Hybrid control deviation too large	✓	✓	✓
Er22-2	Position increment overflow fault	✓	-	✓
Er22-3	CANopen fault–Synchronization signal timeout	✓	✓	✓
Er22-4	CANopen fault–Full position command buffer	✓	✓	✓
Er23-0	Drive overtemperature fault	✓	✓	✓
Er24-0	Communication fault-PWK parameter ID error	-	✓	-
Er24-1	Communication fault-PWK parameter out-of-range	-	✓	-
Er24-2	Communication fault-Read-only PWK parameter	-	✓	-
Er24-3	Communication fault-PZD setting parameter does not exist	-	✓	-
Er24-4	Communication fault-PZD setting parameter property does not match	-	✓	-
Er24-8	EtherCAT fault-Initialization fault	✓	-	✓
Er24-9	EtherCAT fault-EEPROM fault	✓	-	✓
Er24-a	EtherCAT fault-DC Sync0 signal exception	✓	✓	✓
Er24-b	EtherCAT fault-Disconnection fault	✓	✓	✓
Er24-c	EtherCAT fault-PDO data loss fault	✓	✓	✓
Er25-2	Application fault–Phase sequence detection timeout	✓	✓	✓
Er25-3	Application fault–Phase sequence detection failed	✓	✓	✓
Er25-4	Application fault–Encoder offset angle test timeout	✓	✓	✓
Er25-5	Application fault–Encoder offset angle test failed	✓	✓	✓
Er25-6	Application fault–Homing offside	✓	✓	✓
Er25-7	Application fault–Inertia identifying failed	✓	✓	✓
Er25-8	Application fault–Magnetic pole detection failed	✓	✓	✓

Fault code	Name	Attribute		
		History record	Can be cleared	Disable
Er25-9	Application fault–Overtravel/overspeed in confirmation of magnetic pole detection	✓	✓	✓
Er25-a	Application fault–Out-of-range in magnetic pole detection	✓	✓	✓
Er25-b	Application fault–Short-circuit detection fault 1	✓	✓	✓
Er25-c	Application fault–Short-circuit detection fault 2	✓	✓	✓
Er25-d	Application fault–Short-circuit detection fault 3	✓	✓	✓
Er25-e	Application fault–Short-circuit detection fault 4	✓	✓	✓
Er25-f	Application fault–Short-circuit detection fault 5	✓	✓	✓
Er26-0	CANopen fault–SDO timeout	-	✓	-
Er26-1	CANopen fault–SDO index does not exist	-	✓	-
Er26-2	CANopen fault–SDO sub index does not exist	-	✓	-
Er26-3	CANopen fault–SDO data length error	-	✓	-
Er26-4	CANopen fault–SDO write data beyond the range	-	✓	-
Er26-5	CANopen fault–Read-only and non-modifiable	-	✓	-
Er26-6	CANopen fault–PDO mapping length error	-	✓	-
Er26-7	CANopen fault–PDO mapping data does not exist	-	✓	-
Er26-8	CANopen fault–PDO is not allowed to be changed during operating	-	✓	-
Er26-9	CANopen fault–PDO mapping is not allowed	-	✓	-
Er26-a	CANopen fault–Sync signal is too fast	-	✓	-
Er26-b	CANopen fault–Receiving fault	-	✓	-
Er26-c	CANopen fault–Sending fault	-	✓	-
Er26-d	CANopen fault–Sync signal repeat	-	✓	-
Er26-e	CANopen fault–Bus load ratio too high	-	✓	-
Er26-f	CANopen fault–Incorrect parameter modification state	-	✓	-

10.2 Drive faults and solutions

Fault code	Name	Possible cause	Solution
Er01-0	IGBT fault	<ul style="list-style-type: none"> ●The drive actual output current exceeds the specified value. ●Drive fault (such as drive circuit or IGBT fault). ●Motor cables U, V, and W are short connected, or motor cables are grounded or contacted improperly. ●The motor breaks down. ●The motor cables U, V, and W are connected in reverse phases. ●Improper parameter settings cause system exception. ●The ACC/DEC time in the start or stop process is too short. ●Instantaneous load is too heavy. 	<ul style="list-style-type: none"> ●Remove the motor cables and then enable the drive. If the fault persists, replace the drive. ●Ensure the motor cables and wiring are in good conditions. ●Reduce the settings of P0.10 and P0.11 to reduce the maximum output torque. ●Increase the ACC/DEC time. ●Replace the drive with a new one with greater power. ●Replace the motor.
Er01-1	Braking pipe fault (7.5kW and above models)	<ul style="list-style-type: none"> ●Braking unit fault 	<ul style="list-style-type: none"> ●Replace the drive.
Er01-2	U-phase IGBT fault	<ul style="list-style-type: none"> ●U-phase IGBT braking pipe fault 	<ul style="list-style-type: none"> ●Replace the drive.
Er01-3	V-phase IGBT fault	<ul style="list-style-type: none"> ●V-phase IGBT braking pipe fault 	<ul style="list-style-type: none"> ●Replace the drive.
Er01-4	W-phase IGBT fault	<ul style="list-style-type: none"> ●W-phase IGBT braking pipe fault 	<ul style="list-style-type: none"> ●Replace the drive.
Er01-5	IPM fault	<ul style="list-style-type: none"> ●The drive actual output current exceeds the specified value. ●Drive fault (such as drive circuit or IGBT fault). ●Motor cables U, V, and W are short connected, or motor cables are grounded or 	<ul style="list-style-type: none"> ●Remove the motor cables and then enable the drive. If the fault persists, replace the drive. ●Ensure the motor cables and wiring are in good conditions. ●Reduce the settings of P0.10

Fault code	Name	Possible cause	Solution
		contacted improperly. ●The motor breaks down. ●The motor cables U, V, and W are connected in reverse phases. ●Improper parameter settings cause systematic divergence. ●The ACC/DEC time in the start or stop process is too short. ●Instantaneous load is too heavy.	and P0.11 to reduce the maximum output torque. ●Increase the ACC/DEC time. ●Replace the drive with a new one with greater power. ●Replace the motor.
Er02-0	Encoder fault-Encoder disconnection		
Er02-1	Encoder fault-Encoder feedback deviation too large	●The encoder is not connected. ●The encoder plug contact is loose.	●Connect the encoder according to the correct wiring method. Ensure the encoder plug contact is proper. Replace the encoder cable if the cable is broken.
Er02-2	Encoder fault-odd/even check error	●One of encoder signal cables U, V, W, A, B, and Z is disconnected. ●Encoder phases A and B are reverse.	●Ensure the encoder power voltage is proper.
Er02-3	Encoder fault-CRC check error	●Noise causes communication interruption or data exceptions.	●Eliminate the conditions that disturb encoder cables. Route encoder cables and motor cables separately.
Er02-4	Encoder fault-Frame error	●The encoder communicates properly but with data exceptions.	Connect the shielded cables for the encoder to the FG.
Er02-5	Encoder fault-Short frame error	●The FPGA that communicates with the encoder reports timeout.	●If an encoder disconnection fault is reported during power-on, check the setting of P0.01 and then ensure the encoder type supported by the drive is the same as the actual encoder type.
Er02-6	Encoder fault-Encoder communication timeout	●The drive does not support the encoder type.	
Er02-7	Encoder fault-Encoder multi-turn error		

Fault code	Name	Possible cause	Solution
Er02-8	Encoder fault-Encoder battery low-voltage alarm	<ul style="list-style-type: none"> When a multi-turn absolute encoder is used, the external battery voltage of the encoder is between 3.0V-3.2V. 	<ul style="list-style-type: none"> Ensure the encoder battery cable is connected properly. Use the multimeter to check whether the external battery voltage is lower than 3.2V. If yes, replace the battery. Replace the battery when the drive power is on. Otherwise, encoder data will be lost.
Er02-9	Encoder fault-Encoder battery undervoltage fault	<ul style="list-style-type: none"> When a multi-turn absolute encoder is used, the external battery voltage of the encoder is between 2.5V-3.0V. 	<ul style="list-style-type: none"> Ensure the encoder battery cable is connected properly. Use the multimeter to check whether the external battery voltage is lower than 3.0V. If yes, replace the battery. Replace the battery when the drive power is on. Otherwise, encoder data will be lost.
Er02-a	Encoder fault-Encoder overheating	<ul style="list-style-type: none"> The encoder feedback temperature is higher than the temperature threshold for protection against overheating. 	<ul style="list-style-type: none"> Ensure the temperature threshold for protection against overheating is correct. Stop the motor to lower the encoder temperature.
Er02-b	Encoder fault-Encoder EEPROM writing error	<ul style="list-style-type: none"> If the motor is used with a communication encoder, a communication transmission or data check error occurs when the drive updates data to the encoder EEPROM. 	<ul style="list-style-type: none"> Ensure encoder cables are connected properly and eliminate the conditions that disturb encoder communication. Make multiple writing attempts. If the fault is reported repeatedly, replace the motor.
Er02-c	Encoder fault-No data in encoder EEPROM	<ul style="list-style-type: none"> If the motor is used with a communication encoder, no data is found in the encoder EEPROM when the motor 	<ul style="list-style-type: none"> Select the motor model based on the setting of P0.00 and execute the operation of writing data to the encoder

Fault code	Name	Possible cause	Solution
		attempts to read data from it during power-on.	EEPROM through P4.97. ●Mask this fault by setting P4.98. The motor parameters in the drive EEPROM are used for initialization.
Er02-d	Encoder fault-Encoder EEPROM data check error	●If the motor is used with a communication encoder, a data check error occurs in the encoder EEPROM when the motor attempts to read data from it during power-on.	●Ensure encoder cables are connected properly and eliminate the conditions that disturb encoder communication. ●Select the motor model based on the setting of P0.00 and execute the operation of writing data to the encoder EEPROM through P4.97 so that data in the encoder EEPROM is updated. ●Mask this fault by setting P4.98. The motor parameters in the drive EEPROM are used for initialization.
Er02-e	Encoder fault-Encoder identification error	●FPGA initialization has not been completed.	●Perform repower-on, if the fault is reported repeatedly, contact the manufacturer or replace the drive.
Er02-f	Encoder fault-Failed to write the encoder offset angle	●The drive failed to write the encoder offset angle to the FPGA.	●Contact the manufacturer or replace the drive.
Er03-0	Current sensor fault-Phase-U current sensor fault	●The current sensor or detection circuit is abnormal. ●Power-on is made when the motor shaft is in non-static state.	●Re-power on when the motor is in static state. If the fault is reported repeatedly, replace the drive.
Er03-1	Current sensor fault-Phase-V current sensor fault		
Er03-2	Current sensor fault-Phase-W		

Fault code	Name	Possible cause	Solution
	current sensor fault		
Er04-0	System initialization fault	<ul style="list-style-type: none"> There are failed items in self-check after the system power-on initialization process is completed. 	<ul style="list-style-type: none"> Perform repower-on. If the fault occurs repeatedly, replace the drive.
Er04-1	Motor code initialization check failed	<ul style="list-style-type: none"> The motor model saved in the encoder EEPROM read by the drive is not consistent with the motor model saved in the servo EEPROM before the last power failure. 	<ul style="list-style-type: none"> Perform soft reset again. Set the correct motor type.
Er05-0	Setting fault–Motor model not exist	<ul style="list-style-type: none"> P9.50 is set incorrectly. 	<ul style="list-style-type: none"> Ensure the drive model is set correctly and the parameter value is within the allowed range.
Er05-1	Setting fault–Motor model not exist	<ul style="list-style-type: none"> P0.00 is set incorrectly. 	<ul style="list-style-type: none"> Ensure the motor model is set correctly.
Er05-2	Setting fault–Motor and drive model not match		<ul style="list-style-type: none"> Ensure the motor parameter model matches the drive power class.
Er05-3	Setting fault–Incorrect software limits	<ul style="list-style-type: none"> Software limits are set incorrectly. The setting of P0.35 is equal to or less than that of P0.36. 	<ul style="list-style-type: none"> Reset P0.35 and P0.36.
Er05-4	Setting fault–Incorrect homing mode	<ul style="list-style-type: none"> P5.10 is set incorrectly. 	<ul style="list-style-type: none"> Set P5.10 correctly according to the instructions.
Er05-5	Setting fault–PTP-control travel overflow	<ul style="list-style-type: none"> The single increment of a PTP idle travel exceeds (231-1). 	<ul style="list-style-type: none"> Ensure a single travel is not greater than (231 - 1) in absolute position mode.
Er05-6	Setting fault–Power module setting error	<ul style="list-style-type: none"> P9.37 is set incorrectly. 	<ul style="list-style-type: none"> Ensure the drive model is set correctly and the parameter value is within the allowed range.
Er07-0	Regenerative discharge overload fault	<ul style="list-style-type: none"> The braking resistor power is low. The motor speed is too high or 	<ul style="list-style-type: none"> Replace the internal braking resistor with an external one and increase the power.

Fault code	Name	Possible cause	Solution
		the deceleration is too quick, which causes the failure to absorb the regenerate energy within specified time. ●The action limit of the external braking resistor is restricted to the duty ratio 10%.	●Modify the deceleration time and reduce the regenerative discharge action rate. ●Reduce the motor speed. ●Improve the capacity of the motor and drive.
Er08-0	AI overvoltage fault-AI 1	●The voltage input to the analog input 1 port exceeds the setting of P3.22.	●Set P3.22, P3.25 and P3.75 correctly. ●Ensure the terminal wiring is proper. ●Set P3.22, P3.25 and P3.75 to 0 to disable protection.
Er08-1	AI overvoltage fault-AI 2	●The voltage input to the analog input 2 port exceeds the setting of P3.25.	
Er08-2	AI overvoltage fault-analog input 3	●The voltage input to the analog input 3 port exceeds the setting of P3.75.	
Er09-0	EEPROM fault-Read/write error	●Data is damaged in the data storage area when the drive reads data from the EEPROM. ●Writing data to the EEPROM is disturbed.	●Try again after re-power on. ●If the fault occurs repeatedly, replace the drive.
Er09-1	EEPROM fault-Data check error	●The data read from EEPROM during power-on is different from the data that is written. ●The drive DSP version is updated.	●Set all parameters again. ●If the fault occurs repeatedly, replace the drive.
Er10-0	Hardware fault-FPGA fault	●The FPGA on the control board reports a fault.	●Perform repower-on. ●If the fault occurs repeatedly, replace the drive.
Er10-1	Hardware fault-Communication card fault	●The external communication card reports a fault.	●Perform repower-on. ●If the fault occurs repeatedly, replace the communication card.
Er10-2	Hardware fault-To-ground short circuit fault	●One of the motor cables V and W is short connected to the ground, which is found in to-ground short circuit	●Ensure motor cables are connected properly. ●Replace motor cables or check for aging of insulation.

Fault code	Name	Possible cause	Solution
		detection during drive power-on.	
Er10-3	Hardware fault-External input fault	<ul style="list-style-type: none"> ● This fault occurs when the digital terminal configured with the external fault input function acts. 	<ul style="list-style-type: none"> ● Clear the external fault input and enable fault clearing. ● Re-power on the drive.
Er10-4	Hardware fault-Emergency stop fault	<ul style="list-style-type: none"> ● This fault occurs when the emergency stop button is operated (digital terminal is configured with emergency stop function). 	<ul style="list-style-type: none"> ● Cancel the emergency stop input and enable fault clearing. ● Re-power on the drive.
Er10-5	Hardware fault-485 communication fault	<ul style="list-style-type: none"> ● Strong EMI on RS485 communication circuit causes a drive serial communication alarm. 	<ul style="list-style-type: none"> ● Use shielded twisted pairs for RS485 communication. ● Route communication cables and motor cables separately.
Er10-7	Hardware fault-Fan fault	<ul style="list-style-type: none"> ● The fan built in the servo unit stops running. 	<ul style="list-style-type: none"> ● Check whether there is a foreign material. If the alarm persists after the foreign material is found and removed, replace the drive.
Er10-8	Hardware fault-Regenerative transistor fault	<ul style="list-style-type: none"> ● The external regenerative brake resistor is connected improperly or disconnected. 	<ul style="list-style-type: none"> ● Check the connections B2 and B3 when the regenerative brake resistor is built in. ● Ensure the external regenerative brake resistor is connected properly.
Er10-9	Hardware fault-STO phase loss	<ul style="list-style-type: none"> ● There is a phase loss in safety terminal input. 	<ul style="list-style-type: none"> ● Check the safety terminal input wiring.
Er10-a	Hardware fault-STO DPIN1 fault	<ul style="list-style-type: none"> ● Safety terminal input 1 is abnormal. 	<ul style="list-style-type: none"> ● Check the safety terminal input wiring.
Er10-b	Hardware fault-STO DPIN2 fault	<ul style="list-style-type: none"> ● Safety terminal input 2 is abnormal. 	<ul style="list-style-type: none"> ● Check the safety terminal input wiring.

Fault code	Name	Possible cause	Solution
Er10-e	STO terminal fault	<ul style="list-style-type: none"> ●The STO function is set to disable, and the STO terminals are not plugged in. 	<ul style="list-style-type: none"> ●Check whether STO terminal is inserted. ●Check whether terminal wiring of STO is proper.
Er11-0	Software fault–Motor control task re-entry	<ul style="list-style-type: none"> ●The DSP CPU utilization is too high. ●DSP software fault 	<ul style="list-style-type: none"> ●Disable unnecessary functions. ●Contact the customer service personnel to update the DSP.
Er11-1	Software fault–Periodic task re-entry		
Er11-2	Software fault–Illegal operation		
Er12-0	I/O fault–Duplicate DI assignment	<ul style="list-style-type: none"> ●Two or more digital inputs are configured with the same function. 	<ul style="list-style-type: none"> ●Reset P3.00–P3.09 and ensure each setting is unique.
Er12-1	I/O fault–Duplicate AI assignment	<ul style="list-style-type: none"> ●When the drive is a standard model, analog inputs 1–3 are configured as repetitive command inputs. 	<ul style="list-style-type: none"> ●Check whether analog inputs 1–3 are assigned repeatedly and whether their values are correct.
Er12-2	I/O fault–Pulse input frequency too high	<ul style="list-style-type: none"> ●The pulse input frequency detected by the drive is higher than the specified frequency. ●External input pulse signal frequency is too high. ●The internal pulse frequency detection circuit of the drive is damaged. 	<ul style="list-style-type: none"> ●Reduce the external input pulse signal frequency. ●If the fault persists though the external input signal is normal, replace the drive.
Er13-0	Main circuit overvoltage fault	<ul style="list-style-type: none"> ●The detected main circuit DC voltage of the drive exceeds the specified value. ●The grid voltage is too high. ●Under the braking condition, no braking resistor or pipe is connected, or the braking resistor is damaged. ●The DEC time in the stop 	<ul style="list-style-type: none"> ●Ensure the grid input voltage is within the allowed range. ●Ensure the internal braking resistor is not loose or damaged. Ensure the external braking resistor is not damaged. ●Increase the DEC time. ●Check R0.07 when the drive is

Fault code	Name	Possible cause	Solution
		process is too short. ●The internal DC voltage detection circuit of the drive is damaged.	disabled. If it is abnormal and does not match the grid input voltage, replace the drive.
Er13-1	Main circuit undervoltage fault	●The detected main circuit DC voltage of the drive is lower than the specified value. ●The grid voltage is too low. ●The buffer relay is not closed. ●The drive output power is too high. ●The internal DC voltage detection circuit of the drive is damaged.	●Ensure the grid input voltage is within the allowed range. ●Repower on the drive. Ensure the buffer relay is closed. If the buffer relay is closed, there is a sound indicating actuation. ●Check R0.07 when the drive is disabled. If it is abnormal and does not match the grid input voltage, replace the drive.
Er14-0	Control power undervoltage fault	●The detected control power DC voltage of the drive is lower than the specified value. ●The grid voltage is too low. ●The internal control power DC voltage detection circuit of the drive is damaged.	●Ensure the grid input voltage is within the allowed range. ●Check R0.08 when the drive is disabled. If it is abnormal and does not match the grid input voltage, replace the drive.
Er17-0	Drive overload fault		●The load is too heavy which causes the drive overload.
Er17-1	Drive overload fault 2	●The short-time load on the drive is too heavy.	●Check whether phase dislocation or phase loss occurred to UVW wiring of the motor, and check whether the encoder is correct. ●Check whether the motor is compatible with the drive.
Er18-0	Motor overload fault	●Long-term overload running. ●The load is too heavy during the short time.	●Replace the drive and motor with the new ones with greater power.

Fault code	Name	Possible cause	Solution
Er18-1	Motor overtemperature fault	<ul style="list-style-type: none"> ●Temperature of medium-power motor exceeds the protection threshold. 	<ul style="list-style-type: none"> ●Replace with a motor with greater power, or conduct reliable cooling for the motor.
Er18-2	Motor three-phase loss fault	<ul style="list-style-type: none"> ●Any two phases or three phases of the motor power cable are not reliably connected to the drive, or the inside of the motor has been damaged. 	<ul style="list-style-type: none"> ●Check whether the motor power cable is broken or disconnected. ●Check whether the power cable terminal and the drive are plugged tightly. ●Check whether the power cable terminal and the power cable are connected reliably. ●Check whether the motor is damaged. ●Check whether the drive U, V, and W outputs are normal.
Er18-4	Motor U-phase loss fault	<ul style="list-style-type: none"> ●U phase of the motor power cable are not reliably connected to the drive, or the inside of the motor has been damaged. ●The detection time for motor phase loss is set too short. 	<ul style="list-style-type: none"> ●Check whether the motor power cable is broken or disconnected. ●Check whether the power cable terminal and the drive are plugged tightly. ●Check whether the power cable terminal and the power cable are connected reliably. ●Check whether the motor is damaged. ●Ensure that the wiring and equipment are normal, and this function can be switched off by setting P4.77 to 0.
Er18-5	Motor V-phase loss fault	<ul style="list-style-type: none"> ●V phase of the motor power cable are not reliably connected to the drive, or the inside of the motor has been damaged. 	<ul style="list-style-type: none"> ●Check whether the motor power cable is broken or disconnected. ●Check whether the power cable terminal and the drive

Fault code	Name	Possible cause	Solution
		<ul style="list-style-type: none"> ●The detection time for motor phase loss is set too short. 	<ul style="list-style-type: none"> are plugged tightly. ●Check whether the power cable terminal and the power cable are connected reliably. ●Check whether the motor is damaged. ●Ensure that the wiring and equipment are normal, and this function can be switched off by setting P4.77 to 0.
Er18-6	Motor W-phase loss fault	<ul style="list-style-type: none"> ●W phase of the motor power cable are not reliably connected to the drive, or the inside of the motor has been damaged. ●The detection time for motor phase loss is set too short. 	<ul style="list-style-type: none"> ●Check whether the motor power cable is broken or disconnected. ●Check whether the power cable terminal and the drive are plugged tightly. ●Check whether the power cable terminal and the power cable are connected reliably. ●Check whether the motor is damaged. ●Ensure that the wiring and equipment are normal, and this function can be switched off by setting P4.77 to 0.
Er18-7	Motor temperature detection disconnection fault	<ul style="list-style-type: none"> ●The wiring for motor temperature detection is disconnected. 	<ul style="list-style-type: none"> ●Check whether the wiring of the motor temperature detection is normal.
Er19-0	Speed fault-Overspeed fault	<ul style="list-style-type: none"> ●The absolute value of motor speed exceeds the set value of P4.32. ●The motor stalls or motor phases U, V, and W are in reverse sequence. ●The electronic gear ratio or motor speed loop control parameters are not set 	<ul style="list-style-type: none"> ●Check whether the electronic gear ratio parameters are set properly. ●Check the setting of speed loop control parameters. ●Check whether the motor cable phase sequence is correct. ●Check whether the motor

Fault code	Name	Possible cause	Solution
		properly. ●The setting of P4.32 is less than that of P4.31 [Max. speed limit]. ●The encoder feedback signal is interfered.	encoder is wired properly. ●Replace the motor with a new one with a higher speed.
Er19-1	Speed fault-FWD overspeed fault	●The speed feedback is greater than the set value of P4.40 and also exceeds 20ms.	●Ensure the encoder is normal. ●Set P4.40 properly.
Er19-2	Speed fault-REV overspeed fault	●The speed feedback is greater than the set value of P4.41 and also exceeds 20ms.	●Ensure the encoder is normal. ●Set P4.41 properly.
Er19-3	Speed fault-Incorrect overspeed parameter setting	●P4.40 is set to be less than 0, or P4.41 is set to be greater than 0.	●Ensure the encoder is connected properly. ●Set P4.40 or P4.41 properly.
Er19-4	Overspeed fault-Out-of-control fault	●The servo motor is out of control.	●Ensure the encoder is connected properly. ●Check whether the power cable phase sequence is correct. ●Set P4.35 to 0 to disable out-of-control speed detection.
Er20-0	Speed out-of-tolerance fault	●In non-torque mode, the deviation between the motor speed and the speed command exceeds the set value of P4.39. ●The motor phases U, V, and W are in reverse sequence or motor cables are not connected. ●The motor load is too heavy, which causes motor stalling. ●The drive force is insufficient, which causes motor stalling.	●Ensure the motor phases are in correct sequence and motor cables are connected properly. ●Check whether the conveyor belt or chain is too tight or the workbench reaches the boundary or encounters obstacles. ●Ensure the speed loop control parameters are set properly, the drive is intact and undamaged, and the

Fault code	Name	Possible cause	Solution
		<ul style="list-style-type: none"> ●The speed loop control parameters are not set properly. ●The setting of P4.39 is too low. 	<p>servo system model is correct.</p> <ul style="list-style-type: none"> ●Increase the setting of P4.39. ●Set P4.39 to 0, which disables the detecting for a speed out-of-tolerance fault.
Er21-0	Position overtravel - FWD overtravel	<ul style="list-style-type: none"> ●In position mode, the CCW limit switch is touched or the accumulated feedback pulse exceeds the setting of P0.35. 	<ul style="list-style-type: none"> ●Check whether FWD limit switch signal is correct. ●Check whether P0.35 is set properly.
Er21-1	Position overtravel - REV overtravel	<ul style="list-style-type: none"> ●In position mode, the REV limit switch is touched or the accumulated feedback pulse exceeds the setting of P0.36. 	<ul style="list-style-type: none"> ●Check whether REV limit switch signal is correct. ●Check whether P0.36 is set properly.
Er22-0	Position out-of-tolerance fault	<ul style="list-style-type: none"> ●Servo response time is too slow. Therefore the residual pulses exceed the setting of P4.33. ●The motor load is too heavy, which causes motor stalling. ●Pulse input frequency is too high, exceeding the max. motor speed. ●The step variable in the position command input exceeds the setting of P4.33. 	<ul style="list-style-type: none"> ●Check whether the conveyor belt or chain is too tight or the workbench reaches the boundary or encounters obstacles. ●Increase the settings of position loop or speed feed-forward gain parameters. Alternatively, increase the setting of P4.33. ●Adjust electronic gear ratio parameters. ●Decrease the variation of position command input.
Er22-1	Hybrid control deviation too large	<ul style="list-style-type: none"> ●In fully-closed loop control, the feedback position deviation between the linear encoder and the encoder exceeds the set value of P4.64. 	<ul style="list-style-type: none"> ●Ensure the motor and load are connected properly. ●Ensure the linear encoder and drive are connected properly. ●Ensure P4.60, P4.61, and P4.62 are set properly.
Er22-2	Position increment overflow fault	<ul style="list-style-type: none"> ●The single variation in the position command after 	<ul style="list-style-type: none"> ●Reduce the single variable in the position command.

Fault code	Name	Possible cause	Solution
		electronic gear ratio conversion exceeds (2231-1).	<ul style="list-style-type: none"> ●Modify the electronic gear ratio to a proper setting.
Er23-0	Drive overtemperature fault	<ul style="list-style-type: none"> ●The ambient temperature of the drive exceeds the specified temperature. ●The drive is overloaded. 	<ul style="list-style-type: none"> ●Reduce the ambient temperature and improve the ventilation condition. ●Replace the servo system with a new one with greater power. ●Increase the ACC/DEC time and reduce the load.
Er24-0	Communication fault-PWK parameter ID error	<ul style="list-style-type: none"> ●The PWK parameter ID is incorrect. 	<ul style="list-style-type: none"> ●View the manual and ensure that the PWK parameter ID is the same as the corresponding parameter ID.
Er24-1	Communication fault-PWK parameter out-of-range	<ul style="list-style-type: none"> ●The PWK parameter value is out of the allowed range. 	<ul style="list-style-type: none"> ●View the manual and ensure that the setting value of PWK parameter is within the allowed range of the corresponding parameter.
Er24-2	Communication fault-Read-only PWK parameter	<ul style="list-style-type: none"> ●Carry out the write operation on the read-only PWK parameter. 	<ul style="list-style-type: none"> ●View the manual and ensure that the operation parameter is readable and writable.
Er24-3	Communication fault-PZD setting parameter does not exist	<ul style="list-style-type: none"> ●The ID of the PZD parameter is incorrect. 	<ul style="list-style-type: none"> ●View the manual and ensure that the PZD configuration parameter ID is the same as the corresponding parameter ID.
Er24-4	Communication fault-PZD setting parameter property does not match	<ul style="list-style-type: none"> ●The PZD parameter is not immediately effective. 	<ul style="list-style-type: none"> ●View the manual and ensure that the PZD configuration parameter takes effect immediately.
Er24-8	Communication fault- EtherCAT communication card initialization fault	<ul style="list-style-type: none"> ●The initialization of EtherCAT communication card failed. 	<ul style="list-style-type: none"> ●Contact the manufacturer or replace the drive.

Fault code	Name	Possible cause	Solution
Er24-9	Communication fault- EtherCAT communication card EEPROM loading fault	<ul style="list-style-type: none"> ●The EtherCAT chip is in poor contact. 	<ul style="list-style-type: none"> ●Use TwinCAT tool to download xml file to EtherCAT EEPROM.
Er24-a	Communication fault-EtherCAT communication DC Sync0 interruption exception fault	<ul style="list-style-type: none"> ●DC Sync0 interruption signal is not detected during a period of time under DC sync working mode. 	<ul style="list-style-type: none"> ●Check whether interruption causes data loss. ●Check whether EtherCAT master can work normally.
Er24-b	Communication fault- EtherCAT communication Port0 disconnection fault	<ul style="list-style-type: none"> ●After the drive is enabled, the network cable is not inserted properly, or the EtherCAT master does not run properly. 	<ul style="list-style-type: none"> ●Check whether network cable is connected properly, the connection mode of network cable is top-in and bottom-out. ●Check the interference problems. ●Check whether EtherCAT master can work properly.
Er24-c	Communication fault-No PDO data in EtherCAT communication DC mode	<ul style="list-style-type: none"> ●No PDO data in EtherCAT communication DC mode 	<ul style="list-style-type: none"> ●No PDO data is received after the drive has been enabled for a period of time.
Er25-2	Application fault-Phase sequence detection timeout	<ul style="list-style-type: none"> ●An exception occurred in the phase sequence detection. 	<ul style="list-style-type: none"> ●Check whether the motor shaft can rotate freely or the load is heavy, and carry out the detection after repower-on.
Er25-3	Application fault-Phase sequence detection failed	<ul style="list-style-type: none"> ●An exception occurred in the phase sequence detection. 	<ul style="list-style-type: none"> ●Check whether the motor shaft can rotate freely or the load is heavy, and carry out the detection after repower-on.
Er25-4	Application fault-Encoder offset angle test	<ul style="list-style-type: none"> ●An exception occurred in the encoder offset angle test. 	<ul style="list-style-type: none"> ●Ensure the motor shaft can rotate freely and then carry out the test after repower-on.

Fault code	Name	Possible cause	Solution
	timeout		
Er25-5	Application fault–Encoder offset angle test failed	<ul style="list-style-type: none"> ●There is great fluctuation in current feedback in the encoder offset angle test. 	<ul style="list-style-type: none"> ●Reduce the setting of P4.53 and then carry out the test after repower-on.
Er25-6	Application fault–Homing offside	<ul style="list-style-type: none"> ●Limit switches or software limits occur during the homing process. 	<ul style="list-style-type: none"> ●Modify the setting of P5.10 and then carry out the test after repower-on.
Er25-7	Application fault–Inertia identifying failed	<ul style="list-style-type: none"> ●During inertia identifying, the motor stops rotating with vibration of longer than 3.5s. ●The actual ACC time for inertia identifying is too short. ●The inertia identifying speed is lower than 150r/min. 	<ul style="list-style-type: none"> ●Improve the mechanical rigidity properly. ●Increase the setting of P1.07. ●Increase the setting of P1.06.
Er25-8	Application fault–Magnetic pole detection failed	<ul style="list-style-type: none"> ●The power cable phase sequence is incorrect. ●The encoder direction conflicts with the power cable phase sequence. ●External force or overload occurs in the magnetic pole detection. 	<ul style="list-style-type: none"> ●Check the wiring of the power cable. ●Check whether the encoder works normally. ●Check whether external force occurs in the motor running.
Er25-9	Application fault–Overtravel/overspeed in <input type="checkbox"/> confirmation of magnetic pole detection	<ul style="list-style-type: none"> ●The motor motion range is too large or speed is too fast in the confirmation of magnetic pole. 	<ul style="list-style-type: none"> ●Increase the setting of P6.70.
Er25-a	Application fault–Out-of-range in magnetic pole detection	<ul style="list-style-type: none"> ●The motor motion range exceeds the specified value in the magnetic pole detection. 	<ul style="list-style-type: none"> ●Increase the settings of P6.60 and P6.61.
Er25-b	Application fault–Short-circuit detection fault 1	<ul style="list-style-type: none"> ●The breakdown and short circuit may occur to lower tubes or brake pipes of phases U, V and W, and the current 	<ul style="list-style-type: none"> ●Contact the manufacturer or replace the drive.

Fault code	Name	Possible cause	Solution
Er25-c	Application fault—Short-circuit detection fault 2	sensor channel is abnormal. ●V-phase lower bridge cannot be turned on, V-phase lower bridge IGBT is open-circuited or its related driving circuit is abnormal. ●V-phase current sensor channel is abnormal. ●The breakdown and short circuit may occur to the upper bridge IGBT of at least one of phases U, V and W, or its related driving circuit is abnormal, resulting in the upper bridge IGBT being conducted for a long time. ●At least one of three phases is shorted to earth PE.	●Check whether there is to-ground short circuit in phases U, V, and W of the drive output. ●Contact the manufacturer or replace the drive.
Er25-d	Application fault—Short-circuit detection fault 3	●The breakdown and short circuit may occur to the lower bridge IGBT of at least one of phases U, V and W, or its related driving circuit is abnormal, resulting in the lower bridge IGBT being conducted for a long time.	●Contact the manufacturer or replace the drive.
Er25-e	Application fault—Short-circuit detection fault 4	●W-phase lower bridge cannot be turned on, W-phase lower bridge IGBT is open-circuited or its related driving circuit is abnormal. ●W-phase current sensor channel is abnormal. ●The breakdown and short circuit may occur to the upper bridge IGBT of at least one of phases U, V and W, or its	●Check whether there is to-ground short circuit in phases U, V, and W of the drive output. ●Contact the manufacturer or replace the drive.

Fault code	Name	Possible cause	Solution
		<p>related driving circuit is abnormal, resulting in the upper bridge IGBT being conducted for a long time.</p> <ul style="list-style-type: none"> ●At least one of three phases is shorted to earth PE. 	
Er25-f	Application fault–Short-circuit detection fault 5	<ul style="list-style-type: none"> ●The breakdown and short circuit may occur to the lower bridge IGBT of at least one of phases U, V and W, or its related driving circuit is abnormal, resulting in the lower bridge IGBT being conducted for a long time. 	<ul style="list-style-type: none"> ●Contact the manufacturer or replace the drive.

10.3 CANopen communication faults and solutions

Fault code	Name	Possible cause	Solution
Er22-3	Synchronization signal timeout	<ul style="list-style-type: none"> ●In Interpolation position mode, the time interval between two adjacent synchronization frame signals is more than twice the communication cycle. 	<ul style="list-style-type: none"> ●Check communication cables to improve communication reliability. ●Ensure the synchronization frame generation interval of the signal generation source is correct.
Er22-4	Full position command buffer	<ul style="list-style-type: none"> ●CANopen PTP position command buffer is full. 	<ul style="list-style-type: none"> ●Increase the time interval for sending PTP control position commands.
Er26-0	SDO timeout	<ul style="list-style-type: none"> ●The master does not receive heartbeat packets from a slave within a period of time. 	<ul style="list-style-type: none"> ●Check communication connection.
Er26-1	SDO index does not exist	<ul style="list-style-type: none"> ●When the SDO reads or writes parameters, the index does not exist in the object dictionary or is not supported by the servo drive. 	<ul style="list-style-type: none"> ●Check the indexes queried by the master and supported by the drive, and modify the EDS file.

Fault code	Name	Possible cause	Solution
Er26-2	SDO sub-index does not exist	<ul style="list-style-type: none"> When the SDO reads or writes parameters, the index exists in the object dictionary, but the sub-index does not exist in the dictionary or is not supported by the servo drive. 	<ul style="list-style-type: none"> Check the indexes and sub-indexes queried by the master and supported by the drive, and modify the EDS file.
Er26-3	Incorrect SDO data length	<ul style="list-style-type: none"> The length information in SDO read or write commands does not match the data length in the servo drive object dictionary. 	<ul style="list-style-type: none"> Adjust the length in SDO read or write commands according to the data length in the servo drive object dictionary.
Er26-4	SDO data out of range	<ul style="list-style-type: none"> The data that the SDO writes exceeds the data range in the servo drive object dictionary. 	<ul style="list-style-type: none"> Adjust the size of data written by the SDO according to the data range in the object dictionary.
Er26-5	Read-only and non-modifiable	<ul style="list-style-type: none"> There are attempts to modify read-only parameters. 	<ul style="list-style-type: none"> Check whether the parameter to be written is read-only data.
Er26-6	Incorrect PDO mapping length	<ul style="list-style-type: none"> The total length of data mapped from the PDO exceeds 64 bits. 	<ul style="list-style-type: none"> Check the total length of PDO mapping.
Er26-7	PDO mapping data does not exist	<ul style="list-style-type: none"> PDO mapping data cannot be found in the object dictionary. 	<ul style="list-style-type: none"> Check whether the PDO mapping index and sub-index exist in the object dictionary.
Er26-8	PDO is not allowed to be changed during operating	<ul style="list-style-type: none"> There are attempts to modify PDO mappings. 	<ul style="list-style-type: none"> Switch the CANopen state machine to pre-operational and then modify PDO mappings.
Er26-9	PDO mapping is not allowed	<ul style="list-style-type: none"> There are attempts to map parameters that disallow mapping to the PDO. 	<ul style="list-style-type: none"> Check whether there are read-only PDO parameters being mapped into RPDO.
Er26-a	Synchronization signal is too fast	<ul style="list-style-type: none"> In synchronization working mode, the number of frames received by a slave exceeds the range supported by the baud rate. 	<ul style="list-style-type: none"> Modify the time interval for the master to send data frame or synchronization frame. Change the communication

Fault code	Name	Possible cause	Solution
			baud rate.
Er26-b	Receiving fault	<ul style="list-style-type: none"> ●CAN communication is offline or the error receiving counter exceeds 128. 	<ul style="list-style-type: none"> ●Check communication connection. ●Restart the servo drive.
Er26-c	Sending fault	<ul style="list-style-type: none"> ●CAN communication is offline or the error sending counter exceeds 128. 	<ul style="list-style-type: none"> ●Check communication connection. ●Restart the servo drive.
Er26-d	Duplicate synchronization signal	<ul style="list-style-type: none"> ●In the case where a slave is configured to generate synchronization signals, external synchronization signals are received. 	<ul style="list-style-type: none"> ●Modify configuration so that there is only one synchronization signal generation source in the entire communication network.
Er26-e	Bus load ratio too high	<ul style="list-style-type: none"> ●In asynchronous working mode, the number of frames received by a slave exceeds the range supported by the baud rate. 	<ul style="list-style-type: none"> ●Modify the time interval for the master to send data frame. ●Modify the transmission mode of the slave TPDO. ●Change the communication baud rate.
Er26-f	Incorrect parameter modification state	<ul style="list-style-type: none"> ●The SDO attempts to modify parameters in a state that disallows modification. 	<ul style="list-style-type: none"> ●Adjust the CANopen state machine to the Pre-OP or OP state and then try to modify parameters.

10.4 EtherCAT communication faults and solutions

Fault code	Name	Possible cause	Solution
Er24-8	Initialization fault	<ul style="list-style-type: none"> ●The EtherCAT chip is in poor contact. 	<ul style="list-style-type: none"> ●Contact us.
Er24-9	EEPROM error	<ul style="list-style-type: none"> ●There is no data in EtherCAT EEPROM or data reading failed. 	<ul style="list-style-type: none"> ●Use TwinCAT tool to download xml file to EtherCAT EEPROM.
Er24-a	DC Sync0 signal exception	<ul style="list-style-type: none"> ●DC Sync0 interruption signal is not detected during a period of time under DC sync working mode. 	<ul style="list-style-type: none"> ●Check whether interruption causes data loss. ●Check whether EtherCAT master can work properly.

Fault code	Name	Possible cause	Solution
Er24-b	Disconnection fault	<ul style="list-style-type: none"> After the drive is enabled, the network cable is not inserted properly, or the EtherCAT master does not run properly. 	<ul style="list-style-type: none"> Check whether network cable is connected properly, the connection mode of network cable is top-in and bottom-out. Check the interference problems. Check whether EtherCAT master can work properly.
Er24-c	PDO data loss fault	<ul style="list-style-type: none"> No PDO data is received after the drive has been enabled for a period of time. 	<ul style="list-style-type: none"> Check whether EtherCAT master can work properly. Check whether interruption causes data loss.

10.5 PROFINET communication faults and solutions

Fault code	Name	Possible cause	Solution
Er24-0	PROFINET fault-PWK parameter ID error	<ul style="list-style-type: none"> The PWK parameter ID is incorrect. 	<ul style="list-style-type: none"> View the manual and ensure that the PWK parameter ID is the same as the corresponding parameter ID.
Er24-1	PROFINET fault-PWK parameter out-of-range	<ul style="list-style-type: none"> The PWK parameter value is out of the allowed range. 	<ul style="list-style-type: none"> View the manual and ensure that the setting value of PWK parameter is within the allowed range of the corresponding parameter.
Er24-2	PROFINET fault-Read-only PWK parameter	<ul style="list-style-type: none"> Carry out the write operation on the read-only PWK parameter. 	<ul style="list-style-type: none"> View the manual and ensure that the operation parameter is readable and writable.
Er24-3	PROFINET fault-PZD setting parameter does not exist	<ul style="list-style-type: none"> The ID of the PZD parameter is incorrect. 	<ul style="list-style-type: none"> View the manual and ensure that the ID of the PZD setting parameter is the same as that of the corresponding parameter.
Er24-4	PROFINET fault-PZD setting parameter	<ul style="list-style-type: none"> The PZD parameter is not immediately effective. 	<ul style="list-style-type: none"> View the manual and ensure that the PZD setting parameter takes effect

Fault code	Name	Possible cause	Solution
	property does not match		immediately.
Er24-5	PROFINET fault–Communication disconnection	<ul style="list-style-type: none"> After the drive is enabled, the network cable is not inserted properly or the PROFINET master does not run properly. 	<ul style="list-style-type: none"> Check whether network cable is connected properly. Check the interference problems. Check whether the PROFINET master works properly.
Er24-6	PROFINET alarm–Communication setting error	<ul style="list-style-type: none"> When P4.10 is not set to bus input, it is enabled through communication or I/O. 	<ul style="list-style-type: none"> Set P4.10 to bus input.
Er24-7	PROFINET alarm–PZD parameter out-of-range	<ul style="list-style-type: none"> PWK parameter is out-of-range 	<ul style="list-style-type: none"> Check the PZD parameter value sent by the master.
Er24-D	PROFINET alarm–Communication disconnection	<ul style="list-style-type: none"> After the first communication is normal, the network cable is not inserted properly or the PROFINET master does not run properly. 	<ul style="list-style-type: none"> Check whether network cable is connected properly. Check the interference problems. Check whether the PROFINET master works properly.

10.6 PROFIDrive communication faults and solutions

Fault code	Name	Possible cause	Solution
Er24-5	PROFIDrive fault–Communication disconnected	<ul style="list-style-type: none"> After the drive is enabled, the network cable is not inserted properly or the master node does not run properly. 	<ul style="list-style-type: none"> Check whether network cable is connected properly. Check the interference problems. Check that the master is working properly.
Er24-6	PROFIDrive fault–Internal communication initialization fault	<ul style="list-style-type: none"> Initialization of the communication inside the drive failed. 	<ul style="list-style-type: none"> Restart the servo drive. Replace the servo drive.

11 Inspection and maintenance

The product internal components will become aging due to the influence of environmental temperature, humidity, dust, vibration and other factors, which causes the potential failure or shortens the service life. Therefore, to extend the product service life and prevent safety hazards, daily inspection and regular maintenance are required.

Check item	Content	Method
Daily inspection: Recommended on each day.		
Ambient environment	Check whether the ambient temperature, humidity, vibration, dust, gas and oil meet the requirements, and whether there is condensation or water droplets inside and outside the machine.	Visual inspection and instrument measurement
	Check whether there are foreign matters, such as tools, or dangerous substances placed nearby.	Visual inspection
Power voltage	Check whether the power voltage between the main circuit and control circuit is normal.	Multimeter or voltage meter
Fan	Check whether the fan runs properly.	Use a tool to check whether the fan is running
Load	Check whether the motor is overloaded or overheating, or it sounds abnormally.	Use a temperature measurement lance to measure the temperature, and listen to act sounds.
Regular maintenance: Recommended on a quarterly basis, especially in harsh environments such as with dust, oil, or corrosive gases. Before regular maintenance, cut off the power and wait at least 15 min.		
Entire machine	Check whether the bolts are tight, loose or come off.	Visual inspection
	Check whether the machine is deformed, cracked, or damaged, or the color changes due to overheating and aging.	Visual inspection
	Check whether much dirt or dust is attached	Visual inspection
	Check whether there is abnormal sound or vibration, odor, discoloration (transformer, reactor and fan).	Auditory inspection, smell, or visual inspection

Check item	Content	Method
Motor	Check whether the installation is secure, motor insulation is normal, and the fan runs properly.	Instrument or visual inspection
Cable	Check whether there is discoloration, deformation, or sheath damage.	Visual inspection
	Check whether the cable connectors or bolts become loose.	Visual inspection
Connection terminal	Check whether there is overheating, discoloration, or damage.	Visual inspection
External braking resistor	Check whether there is displacement caused due to overheating.	Smell, visual inspection
	Check whether aging, skin breakage, or wire damage occurs to the resistor cable.	Visual inspection, or measuring with a multimeter after removing one cable end

For more details about maintenance, contact the local INVT office, or visit our website www.invt.com, and choose **Support > Services**.

Appendix A Parameter list

A.1 Setup parameter list

The special letters and symbols involved in the table are described below.

Function parameter column:

- ✧ The function codes with the superscript of “1” indicate that these parameters can be valid only when the system is reset and restarted or repowered after disconnection.
- ✧ The function codes with the superscript of “2” indicate that these parameters are valid when the servo drive stops. The modification during operation is invalid.
- ✧ The function codes with the superscript of “*” indicate that these parameters are not saved after power off.

Applicable mode column:

- ✧ P: Position mode
- ✧ S: Speed mode
- ✧ T: Torque mode

A.1.1 Function parameter list

Function code	Name	Unit	Range	Default	Applicable mode
P0 Basic control					
P0.00 ¹	Motor model	-	0-9999999	236	PST
P0.01 ¹	Encoder type	-	1-17	1	PST
P0.02 ¹	Forward rotation of motor	-	0-1	0	PST
P0.03 ¹	Control mode selection	-	0-9	0	PST
P0.04*	Internal enabling command	-	0-1	0	PST
P0.05	Jogging speed	r/min	0-1000	200	PST
P0.06 ¹	Numerator of frequency division output coefficient	-	0-(231-1)	10000	PST
P0.07 ¹	Denominator of frequency division	-	1-(231-1)	131072	PST

Function code	Name	Unit	Range	Default	Applicable mode
	output coefficient				
P0.08 ¹	Reverse of frequency division output	-	0-1	0	PST
P0.09	Torque limit mode setting	-	0-6	1	PS
P0.10	Max. torque limit 1	%	0.0-500.0	300.0	PST
P0.11	Max. torque limit 2	%	0.0-500.0	300.0	PS
P0.13 ¹	External braking resistor power	W	0-30000	200	PST
P0.14 ¹	Resistance of the external braking resistor	Ω	1-1000	60	PST
P0.15	Default monitoring parameters	-	0-23	0	PST
P0.16	Parameter modification operation locked	-	0-1	0	PST
P0.17	Mode for writing to EEPROM	-	0-1	0	PST
P0.18*	Factory password	-	0-65535	0	PST
P0.20 ¹	Position command selection	-	0-4	0	P
P0.22 ¹	Pulses per motor resolution	reference unit	0-(231-1)	10000	P
P0.23 ¹	Pulse input form	-	0-2	0	P
P0.24 ¹	Reverse of pulse input direction	-	0-1	0	P
P0.25	Numerator of electronic gear ratio 1	-	0-(231-1)	0	P
P0.26 ²	Denominator of electronic gear ratio	-	1-(231-1)	10000	P
P0.27	Numerator of electronic gear ratio 2	-	0-(231-1)	0	P

Function code	Name	Unit	Range	Default	Applicable mode
P0.28	Numerator of electronic gear ratio 3	-	0-(231-1)	0	P
P0.29	Numerator of electronic gear ratio 4	-	0-(231-1)	0	P
P0.30 ¹	Input selection for 3PH input-type servo power supply	-	0-1	0	PST
P0.31 ¹	Main circuit power AC/DC input selection	-	0-1	0	PST
P0.32	Sudden power-off hold time	ms	20-2000	36	P
P0.332	Smooth filtering of position command	ms	0.0-1000.0	0.0	P
P0.342	FIR filter of position command	ms	0.0-1000.0	0.0	P
P0.35	Software limit in CCW position control	reference unit	-(231-1)-(231-1)	0	P
P0.36	Software limit in CW position control	reference unit	-(231-1)-(231-1)	0	P
P0.37	Position command mode	-	0-1	0	P
P0.38	Fully-closed loop enable	-	0-2	0	P
P0.40	Speed command selection	-	0-5	1	S
P0.41	Setting of speed command direction	-	0-1	0	S
P0.42	Analog input 1 gain	[P3.26 unit]/V	10-2000	100	PST
P0.43	Reverse of AI 1	-	0-1	0	PST

Function code	Name	Unit	Range	Default	Applicable mode
P0.45	Dead zone of AI 1	V	0.000–3.000	0.000	PST
P0.46	Internal speed 1/speed limit 1	r/min	-20000–20000	100	ST
P0.47	Internal speed 2/speed limit 2	r/min	-20000–20000	0	ST
P0.48	Internal speed 3/speed limit 3	r/min	-20000–20000	0	ST
P0.49	Internal speed 4/speed limit 4	r/min	-20000–20000	0	ST
P0.50	Internal speed 5	r/min	-20000–20000	0	S
P0.51	Internal speed 6	r/min	-20000–20000	0	S
P0.52	Internal speed 7	r/min	-20000–20000	0	S
P0.53	Internal speed 8	r/min	-20000–20000	0	S
P0.54	ACC time	ms	0–6000000	200	S
P0.55	DEC time	ms	0–6000000	200	S
P0.56	S-curve ACC time	ms	0–1000	0	S
P0.57	S-curve DEC time	ms	0–1000	0	S
P0.58	Zero speed clamp mode	-	0–3	0	ST
P0.59	Speed threshold of zero speed clamp	r/min	10–20000	30	S
P0.60	Torque command selection	-	0–3	1	T
P0.61	Torque command direction setting	-	0–1	0	T
P0.62	Analog input 2 gain	[P3.27 unit]/V	0–2000	100	PST
P0.63	Reverse of AI 2	-	0–1	0	PST
P0.65	Dead zone of AI 2	V	0.000–3.000	0.000	PST
P0.66	Internal torque command	%	-500.0–500.0	0.0	T
P0.67	Speed limit mode	-	0–1	0	T
P0.68	RAMP time of torque command	ms	0–10000	0	T
P0.69	DEC time for quick stop	ms	0–10000	500	PST
P0.70 ¹	Absolute encoder	-	0–1	0	PST

Function code	Name	Unit	Range	Default	Applicable mode
	mode setting				
P0.71*	Clear absolute encoder multi-turn	-	0-1	0	PST
P0.72	Mechanical gear ratio (numerator) in absolute position rotary mode	-	1-32767	1	PST
P0.73	Mechanical gear ratio (denominator) in absolute position rotary mode	-	1-32767	1	PST
P0.74	Number of pulses per revolution of the load side in absolute position rotary mode (Encoder unit-32 low-order bits)	Encoder unit	0-4294967295	0	PST
P0.75	Number of pulses per revolution of the load side in absolute position rotary mode (Encoder unit-32 high-order bits)	Encoder unit	0-4294967295	0	PST
P0.90	Max. speed limit of control mode switching	r/min	0-1000	100	PST
P0.91	Positioning reference of control mode switching	reference unit	-1-(231-1)	-1	PST
P0.92	Position mode switching exit mode	-	0-1	0	PST

Function code	Name	Unit	Range	Default	Applicable mode
P0.93	Exit mode for switching from speed or torque mode	-	0-1	1	PST
P0.99	Speed detection FIR filtering class	-	1-31	1	PST
P1 Autotuning control					
P1.00	Tune inertia online	-	0-1	0	PST
P1.01	Inertia ratio 1	%	0-10000	250	PST
P1.02	Inertia ratio 2	%	0-10000	250	PST
P1.03	Machine rigidity setting	-	0-31	13	PST
P1.04*	Tune inertia offline	-	0-1	0	PST
P1.05	Operation mode of inertia identification	-	0-3	0	PST
P1.06	Movable range of inertia identification	r	0.2-20.0	2.0	PST
P1.07	ACC time constant of inertia identification	ms	2-1000	200	PST
P1.08	Speed level of inertia identification	-	0-3	1	PST
P1.19	Resonance detection sensitivity	%	0.2-100.0	5.0	PST
P1.20	Resonance detection mode	-	0-7	0	PST
P1.21*	Mechanical resonant frequency 1	Hz	0-5000	5000	PST
P1.22*	Mechanical resonant frequency 2	Hz	0-5000	5000	PST

Function code	Name	Unit	Range	Default	Applicable mode
P1.23	Frequency of notch filter 1	Hz	50–5000	5000	PST
P1.24	Q factor of notch filter 1	-	0.50–16.00	1.00	PST
P1.25	Depth of notch filter 1	%	0–100	0	PST
P1.26	Frequency of notch filter 2	Hz	50–5000	5000	PST
P1.27	Q factor of notch filter 2	-	0.50–16.00	1.00	PST
P1.28	Depth of notch filter 2	%	0–100	0	PST
P1.29	Frequency of notch filter 3	Hz	50–5000	5000	PST
P1.30	Q factor of notch filter 3	-	0.50–16.00	1.00	PST
P1.31	Depth of notch filter 3	%	0–100	0	PST
P1.32	Frequency of notch filter 4	Hz	50–5000	5000	PST
P1.33	Q factor of notch filter 4	-	0.50–16.00	1.00	PST
P1.34	Depth of notch filter 4	%	0–100	0	PST
P1.35	Vibration control mode in position command	-	0–2	0	P
P1.36	Vibration control frequency 1	Hz	0.0–200.0	0.0	P
P1.37	Coefficient of vibration control filter 1	-	0.00–1.00	1.00	P
P1.38	Vibration control frequency 2	Hz	0.0–200.0	0.0	P
P1.39	Coefficient of vibration control filter 2	-	0.00–1.00	1.00	P

Function code	Name	Unit	Range	Default	Applicable mode
P2 Motor control					
P2.00	First speed gain	Hz	0.0–3276.7	27.0	PST
P2.01	First speed integral time constant	ms	0.1–1000.0	21.0	PST
P2.02	First position gain	1/s	0.0–3276.7	48.0	P
P2.03	First speed detection filter	Hz	100–5000	5000	PST
P2.04	First torque filter	ms	0.00–25.00	0.84	PST
P2.05	Second speed gain	Hz	0.0–3276.7	27.0	PST
P2.06	Second speed integral time constant	ms	0.1–1000.0	1000.0	PST
P2.07	Second position gain	1/s	0.0–3276.7	57.0	P
P2.08	Second speed detection filter	Hz	100–5000	5000	PST
P2.09	Second torque filter	ms	0.00–25.00	0.84	PST
P2.10	Speed feed-forward gain	%	0.0–100.0	0.0	P
P2.11	Speed feed-forward filter time	ms	0.00–64.00	0.50	P
P2.12	Torque feed-forward gain	%	0.0–200.0	0.0	PS
P2.13	Torque feed-forward filter time	ms	0.00–64.00	0.00	PS
P2.14	First IPPI coefficient	%	0–1000	100	PST
P2.15	Second IPPI coefficient	%	0–1000	100	PST
P2.20	Second gain setting	-	0–1	1	PST
P2.22	Switching trigger in position control	-	0–9	0	P
P2.23	Switching delay in	ms	0–10000	0	P

Function code	Name	Unit	Range	Default	Applicable mode
	position control				
P2.24	Switching level in position control	-	0-20000	0	P
P2.25	Switching delay in position control	-	0-20000	0	P
P2.26	Position gain switching time	ms	0-10000	0	P
P2.27	Switching mode of speed control	-	0-5	0	S
P2.28	Switching delay in position control	ms	0-10000	0	S
P2.29	Switching level of speed control	-	0-20000	0	S
P2.30	Switching delay in speed control	-	0-20000	0	S
P2.31	Switching mode of torque control	-	0-3	0	T
P2.32	Switching delay in torque control	ms	0-10000	0	T
P2.33	Switching level of torque control	-	0-20000	0	T
P2.34	Switching delay in torque control	-	0-20000	0	T
P2.41 ²	Disturbance observer	-	0-2	0	PST
P2.42	Disturbance observer compensation gain	%	0-100	0	PS
P2.43	Disturbance observer cut-off frequency	Hz	0-3000	200	PS
P2.44	Torque command offset	%	-500.0-500.0	0.0	PST
P2.50 ²	Fully-closed loop vibration suppressor	-	0-2	0	PS

Function code	Name	Unit	Range	Default	Applicable mode
P2.51	Fully-closed loop vibration suppressor cut-off frequency	Hz	1.0–500.0	100.0	PS
P2.52	Fully-closed loop vibration suppressor compensation gain	%	0–1000	0	PS
P2.53	Medium frequency vibration control switch	-	0–1	0	PST
P2.54	Medium frequency vibration control frequency	Hz	1–2000	100	PST
P2.55	Inertia fine tuning of medium frequency vibration control	%	1–1000	100	PST
P2.56	Attenuation gain of medium frequency vibration control	%	0–1000	0	PST
P2.57	Fine tuning of medium frequency vibration control filter time 1	ms	-10.00–10.00	0.00	PST
P2.58	Fine tuning of medium frequency vibration control filter time 2	ms	-10.00–10.00	0.00	PST
P2.60 ²	Speed observer	-	0–2	0	PST
P2.61	Speed observer gain	Hz	1–1000	100	PST
P2.70	Friction compensation cut-off speed	r/min	0–1000	20	PST
P2.71	Positive torque coefficient of	%/(10r/min)	0.0–100.0	0.0	PST

Function code	Name	Unit	Range	Default	Applicable mode
	friction compensation				
P2.72	Negative torque coefficient of friction compensation	%/(10r/min)	-100.0~0.0	0.0	PST
P2.73	Friction compensation	-	0~1	0	PST
P2.74	Automatic mode switch	-	0~1	0	PST
P2.75	Automatic mode gain	Hz	0.0~3276.7	40.0	PST
P2.76	Automatic mode inertia fine-tuning	%	0~1000	100	PST
P2.77	(Reserved)	-	-	-	PST
P2.78	(Reserved)	-	-	-	PST
P2.79	(Reserved)	-	-	-	PST
P2.80	(Reserved)	-	-	-	PST
P2.81	(Reserved)	-	-	-	PST
P2.82	(Reserved)	-	-	-	PST
P2.83	(Reserved)	-	-	-	PST
P2.84	(Reserved)	-	-	-	PST
P2.85	Torque feed-forward selection	-	0~1	0	PS
P2.86	Flux-weakening control switch	-	0~3	0	PST
P2.87	Voltage utilization in flux-weakening control	%	1~99	90	PST
P2.88	Open-loop flux-weakening bandwidth	%	1~500	50	PST
P2.89	Closed-loop flux-weakening bandwidth	%	0.01~100	2.00	PST

Function code	Name	Unit	Range	Default	Applicable mode
P2.90	Max. flux-weakening current in closed-loop flux-weakening control	%	1–100	90	PST
P2.91	Unbiased control gain	1/s	1–2000	300	PST
P2.92	Unbiased control decay coefficient	%	50–200	100	PST
P3 I/O management					
P3.00 ¹	Input configuration of digital 1	-	0x000–0x136	0x003	PST
P3.01 ¹	Input configuration of digital 2	-	0x000–0x136	0x00D	PST
P3.02 ¹	Input configuration of digital 3	-	0x000–0x136	0x004	PST
P3.03 ¹	Input configuration of digital 4	-	0x000–0x136	0x016	PST
P3.04 ¹	Input configuration of digital 5	-	0x000–0x136	0x019	PST
P3.05 ¹	Input configuration of digital 6	-	0x000–0x136	0x01A	PST
P3.06 ¹	Input configuration of digital 7	-	0x000–0x136	0x001	PST
P3.07 ¹	Input configuration of digital 8	-	0x000–0x136	0x002	PST
P3.08 ¹	Input configuration of	-	0x000–0x136	0x007	PST

Function code	Name	Unit	Range	Default	Applicable mode
	digital 9				
P3.09 ¹	Input configuration of digital 10	-	0x000–0x136	0x008	PST
P3.10 ¹	Output configuration of digital 1	-	0x000–0x11F	0x001	PST
P3.11 ¹	Output configuration of digital 2	-	0x000–0x11F	0x003	PST
P3.12 ¹	Output configuration of digital 3	-	0x000–0x11F	0x007	PST
P3.13 ¹	Output configuration of digital 4	-	0x000–0x11F	0x00D	PST
P3.16	Channel 1 DI-captured encoder function configuration	-	0–30A	0	PST
P3.17	Channel 2 DI-captured encoder function configuration	-	0–30A	0	PST
P3.20	Offset of analog input 1	V	-10.000–10.000	0.000	PST
P3.21	Filter of analog input 1	ms	0.0–1000.0	1.0	PST
P3.22	OV protection threshold of analog input 1	V	0.000–10.000	0.000	PST
P3.23	Offset of analog input 2	V	-10.000–10.000	0.000	PST
P3.24	Filter of analog input 2	ms	0.0–1000.0	0.0	PST
P3.25	OV protection threshold of	V	0.000–10.000	0.000	PST

Function code	Name	Unit	Range	Default	Applicable mode
	analog input 2				
P3.26 ¹	Function of analog input 1	-	0-7	0	PST
P3.27 ¹	Function of analog input 2	-	0-7	3	PST
P3.28	Analog speed compensation gain	%	0.0-100.0	0.0	P
P3.29	Analog torque compensation gain	%	0.0-100.0	0.0	PST
P3.30 ¹	Function of analog output 1	-	0-19	0	PST
P3.31	Voltage gain of analog output 1	[P3.30 unit]/V	1-214748364	1	PST
P3.32 ¹	Function of analog output 2	-	0-19	0	PST
P3.33	Voltage gain of analog output 2	[P3.32 unit]/V	1-214748364	1	PST
P3.34	Offset voltage of analog output 1	V	-10.000-10.000	0.000	PST
P3.35	Offset voltage of analog output 2	V	-10.000-10.000	0.000	PST
P3.36 ¹	Analog output monitoring setting	-	0-2	0	PST
P3.37*	Communication-based control analog output 1	-	-2147483648-2147483648	0	PST
P3.38*	Analog output 2	-	-2147483648-2147483648	0	PST
P3.39	Communication-based control I/O output	-	0-0FFF	0	PST
P3.40 ¹	Disable travel limit switch	-	0-2	1	PST
P3.41 ¹	Disable emergency stop switch	-	0-1	1	PST
P3.43 ¹	Digital input filter	0.125ms	1-800	1	PST
P3.44	Command pulse input invalid	-	0-1	0	P

Function code	Name	Unit	Range	Default	Applicable mode
	setting disabling				
P3.45 ¹	Residual pulse clearing mode	-	0-1	1	P
P3.46	Internal speed limit accuracy setting	-	0-1	0	P
P3.50	Range of position arrival	reference unit	0-218	100	P
P3.51	Output mode of position arrival	-	0-4	0	P
P3.52	Hold time of position arrival output terminal	ms	0-30000	0	P
P3.53	Speed consistency threshold	r/min	10-20000	50	PST
P3.54	Speed reaching range	r/min	10-20000	1000	PST
P3.55	Zero speed range	r/min	10-20000	50	PST
P3.56	Servo lock time after braking	ms	0-1000	50	PST
P3.57	Electromagnetic brake closing delay	ms	0-30000	500	PST
P3.58 ¹	Motor speed threshold at brake release	r/min	0-6000	30	PST
P3.59	Torque reaching range	%	5.0-300.0	50.0	T
P3.70 ¹	Function of analog input 3	-	0-7	4	PST
P3.71	Zero offset of analog input 3	V	-10.000-10.000	0.000	PST
P3.72	Dead zone of analog input 3	V	0.000-3.000	0.000	PST
P3.73	Gain of analog input 3	[P3.70 unit]/V	0-2000	300	PST
P3.74	Reverse of analog input 3	-	0-1	0	PST

Function code	Name	Unit	Range	Default	Applicable mode
P3.75	OV protection threshold of analog input 3	V	0.000–10.000	0.000	PST
P3.76	Filter of analog input 3	ms	0.0–1000.0	0.0	PST
P3.77	Analog input deadzone mode	-	0–1	0	PST
P3.89	Probe DI-captured filter time	20ns	1–250	50	PST
P3.90	Pulse input filter time	20ns	1–250	20	PST
P3.91	First encoder filter time	20ns	1–250	20	PST
P3.92	Second encoder filter time	20ns	1–250	20	PST
P4 Extension and application					
P4.00 ¹	EtherCAT node address	-	-1–32767	-1	PST
P4.01 ¹	Local RS485 communication address	-	1–255	1	PST
P4.02 ¹	CAN communication baud rate	-	0–5	1	PST
P4.03 ¹	RS485 communication baud rate	-	0–3	1	PST
P4.04 ¹	RS485 communication parity mode	-	0–5	0	PST
P4.05 ¹	CAN communication node number	-	1–127	1	PST
P4.06	RS485 communication fault clearing mode	-	0–1	1	PST

Function code	Name	Unit	Range	Default	Applicable mode
P4.07 ¹	EtherCAT synchronous cycle	-	0–30	1	PST
P4.08 ¹	EtherCAT synchronous type	-	0–2	0	PST
P4.09 ¹	EtherCAT fault detection time	ms	0–1000	100	PST
P4.10 ¹	Upper computer type	-	0–1	0	PST
P4.11*	Bus servo enabling	-	0–1	0	PST
P4.12*	Bus position command	reference unit	-(231-1)–(231-1)	0	P
P4.13*	Bus speed command	r/min	-6000–6000	0	S
P4.14*	Bus torque command	%	-500.0–500.0	0.0	T
P4.15*	Control mode switching command	-	0–1	0	PST
P4.16*	Gain switching command	-	0–1	0	PST
P4.17*	Electronic gear ratio switching command	-	0–3	0	P
P4.18*	Inertia ratio switching command	-	0–1	0	PST
P4.19*	Zero speed clamp command	-	0–1	0	ST
P4.20*	Residual pulses clearing	-	0–1	0	P
P4.21*	Torque limit switching command	-	0–1	0	PST
P4.22*	External fault command	-	0–1	0	PST
P4.23*	Emergency stop command	-	0–1	0	PST

Function code	Name	Unit	Range	Default	Applicable mode
P4.24*	Input command of vibration control switching	-	0-1	0	P
P4.25	EtherCAT control unit type	-	0-3	1	PS
P4.26	EtherCAT PDO input offset	125μs	0-63	3	PS
P4.27	Compensation times of EtherCAT position interpolation mode	-	0-10	0	PS
P4.28 ¹	EtherCAT digital output control enable	-	0-1	0	PS
P4.29 ¹	Check the EtherCAT synchronization cycle settings	-	0-1	0	PS
P4.30	Stop mode	-	0-3	0	PST
P4.31	Max. speed limit	r/min	0-20000	5000	PST
P4.32	Overspeed threshold	r/min	0-20000	6000	PST
P4.33	Pulse threshold of position deviation	reference unit	0-227	100000	P
P4.34 ¹	Brake overload detection selection	-	0-4	4	PST
P4.35	Enable out-of-control speed detection	-	0-1	0	PST
P4.36 ¹	Main power UV protection	-	0-1	1	PST
P4.37	Main power UV detection time	ms	70-2000	70	PST
P4.38	Motor overload setting	%	0.0-500.0	115.0	PST

Function code	Name	Unit	Range	Default	Applicable mode
P4.39	Speed deviation setting	r/min	0–20000	0	PS
P4.40	Forward speed limit	r/min	0–20000	20000	PST
P4.41	Reverse speed limit	r/min	-20000–0	-20000	PST
P4.42	Internal speed with high resolution	r/min	-20000.0–20000.0	0.0	PST
P4.43	EtherCAT-related control	-	0–3FFF	2183	PST
P4.44	Out-of-control speed threshold	r/min	0–20000	600	PST
P4.50 ¹	Encoder phase-Z offset	pulse	0–(220-1)	0	PST
P4.51	Torque limit switching time 1	ms/100%	0–4000	0	PS
P4.52	Torque limit switching time 2	ms/100%	0–4000	0	PS
P4.53	Current loop response adjustment	%	10.0–200.0	100.0	PST
P4.54 ¹	Delay after power-on initialization	ms	0–200000	0	PST
P4.58 ¹	Z pulse width of frequency-division output	pulse	1–255	2	PST
P4.59	Z pulse offset of frequency-division output	pulse	0–(231-1)	0	PST
P4.60 ¹	Frequency-division numerator of external linear encoder	-	1–(231-1)	10000	P
P4.61 ¹	Frequency-division denominator of	-	1–(231-1)	10000	P

Function code	Name	Unit	Range	Default	Applicable mode
	external linear encoder				
P4.62 ¹	Direction reversal of external linear encoder	-	0-1	0	P
P4.64 ¹	Hybrid control deviation limit	pulse	0-227	160000	P
P4.65 ¹	Threshold for hybrid-control deviation clearing	r	0-100	0	P
P4.67 ¹	External linear encoder pulse output mode of phase AB	-	0-1	0	P
P4.68 ¹	External linear encoder (or encoder 2) resolution	pulse	1-(231-1)	10000	P
P4.69 ¹	Frequency division output source	-	0-4	0	PST
P4.70 ¹	External linear encoder (second encoder) Z signal type	-	0-3	0	PST
P4.75	User-defined control word (PROFIdrive)	-	0-3	0	PST
P4.76	User-defined state word (PROFIdrive)	-	0-4	3	PST
P4.77	Detection time for motor phase loss	ms	0-800	200	PST
P4.78	Motor overtemperature protection threshold	°C	0-200	0	PST
P4.79 ¹	Quick stop method	-	0-2	2	PST
P4.80	PZD setting	-	1000-3999	1998	PST

Function code	Name	Unit	Range	Default	Applicable mode
	parameter 1 configuration				
P4.81	PZD setting parameter 2 configuration	-	1000-3999	1998	PST
P4.82	PZD setting parameter 3 configuration	-	1000-3999	1998	PST
P4.83	PZD feedback parameter 1 configuration	-	4000-5852	4012	PST
P4.84	PZD feedback parameter 2 configuration	-	4000-5852	4018	PST
P4.85	PZD feedback parameter 3 configuration	-	4000-5852	4032	PST
P4.86	CANopen master heartbeat offset time	-	0-200	2	PST
P4.87	CANopen communication cycle	μs	0-(231-1)	0	PST
P4.88	CANopen heartbeat cycle	ms	0-32767	1000	PST
P4.89	Automatic stop at CANopen disconnection	-	0-1	0	PST
P4.90*	Fault recovery	-	0-1	0	PST
P4.91*	Parameter saving	-	0-1	0	PST
P4.92*	Restore to default values	-	0-1	0	PST
P4.93*	Read fault records	-	0-1	0	PST
P4.94*	Clear fault records	-	0-1	0	PST
P4.95*	Group number of the fault record	-	0-9	0	PST
P4.96*	Encoder initial	-	0-4	0	PST

Function code	Name	Unit	Range	Default	Applicable mode
	angle test				
P4.97*	EEPROM operation of communication encoder	-	0-1	0	PST
P4.98*	EEPROM data fault block of communication encoder	-	0-1	1	PST
P5 Program jog, homing, and PTP control					
P5.00	Jog mode selection	-	0-6	0	P
P5.01	JOG movement amount	reference unit	1-230	50000	P
P5.02	Jogging speed setting	r/min	1-5000	500	P
P5.03	Jogging ACC/DEC time	ms	2-10000	100	P
P5.04	Jogging wait time	ms	0-10000	100	P
P5.05	Jogging cycle times	-	0-10000	1	P
P5.06	Jogging cycle times	-	0-10000	1	P
P5.09	Homing ACC/DEC time	ms	0-6000000	0	S
P5.10 ²	Homing mode	-	0-128	0	P
P5.11	Homing automatically after power-on and homing action	-	0-7FFF	0	P
P5.12	High speed at homing step 1	r/min	0-2000	100	P
P5.13	Low speed at homing step 2	r/min	0-60	20	P
P5.14	Home setting	reference unit	-(231-1)-(231-1)	0	P
P5.15*	Homing trigger command	-	0-1	0	P

Function code	Name	Unit	Range	Default	Applicable mode
P5.16	Homing associated action	-	0-3	0	P
P5.17	Target speed after homing	r/min	1-5000	100	P
P5.18	ACC/DEC time for target speed after homing	ms	0-32767	300	P
P5.19	Target position after homing	reference unit	-(231-1)-(231-1)	0	P
P5.20*	PTP trigger signal	-	-1-2048	-1	P
P5.21	Target speed 00	r/min	0-6000	20	P
P5.22	Target speed 01	r/min	0-6000	50	P
P5.23	Target speed 02	r/min	0-6000	100	P
P5.24	Target speed 03	r/min	0-6000	200	P
P5.25	Target speed 04	r/min	0-6000	300	P
P5.26	Target speed 05	r/min	0-6000	500	P
P5.27	Target speed 06	r/min	0-6000	600	P
P5.28	Target speed 07	r/min	0-6000	800	P
P5.29	Target speed 08	r/min	0-6000	1000	P
P5.30	Target speed 09	r/min	0-6000	1300	P
P5.31	Target speed 10	r/min	0-6000	1500	P
P5.32	Target speed 11	r/min	0-6000	1800	P
P5.33	Target speed 12	r/min	0-6000	2000	P
P5.34	Target speed 13	r/min	0-6000	2300	P
P5.35	Target speed 14	r/min	0-6000	2500	P
P5.36	Target speed 15	r/min	0-6000	3000	P
P5.37	ACC/DEC time 00	ms	0-32767	200	P
P5.38	ACC/DEC time 01	ms	0-32767	300	P
P5.39	ACC/DEC time 02	ms	0-32767	500	P
P5.40	ACC/DEC time 03	ms	0-32767	600	P
P5.41	ACC/DEC time 04	ms	0-32767	800	P
P5.42	ACC/DEC time 05	ms	0-32767	900	P
P5.43	ACC/DEC time 06	ms	0-32767	1000	P
P5.44	ACC/DEC time 07	ms	0-32767	1200	P
P5.45	ACC/DEC time 08	ms	0-32767	1500	P
P5.46	ACC/DEC time 09	ms	0-32767	2000	P

Function code	Name	Unit	Range	Default	Applicable mode
P5.47	ACC/DEC time 10	ms	0-32767	2500	P
P5.48	ACC/DEC time 11	ms	0-32767	3000	P
P5.49	ACC/DEC time 12	ms	0-32767	5000	P
P5.50	ACC/DEC time 13	ms	0-32767	8000	P
P5.51	ACC/DEC time 14	ms	0-32767	50	P
P5.52	ACC/DEC time 15	ms	0-32767	30	P
P5.53	Delay time 00	ms	0-32767	0	P
P5.54	Delay time 01	ms	0-32767	100	P
P5.55	Delay time 02	ms	0-32767	200	P
P5.56	Delay time 03	ms	0-32767	400	P
P5.57	Delay time 04	ms	0-32767	500	P
P5.58	Delay time 05	ms	0-32767	800	P
P5.59	Delay time 06	ms	0-32767	1000	P
P5.60	Delay time 07	ms	0-32767	1500	P
P5.61	Delay time 08	ms	0-32767	2000	P
P5.62	Delay time 09	ms	0-32767	2500	P
P5.63	Delay time 10	ms	0-32767	3000	P
P5.64	Delay time 11	ms	0-32767	3500	P
P5.65	Delay time 12	ms	0-32767	4000	P
P5.66	Delay time 13	ms	0-32767	4500	P
P5.67	Delay time 14	ms	0-32767	5000	P
P5.68	Delay time 15	ms	0-32767	5500	P
P5.69	PTP control buffer switch	-	0-1	1	P
P5.70	Disk single-turn resolution	pulse	-(231-1)-(231-1)	10000	P
P5.71	Disk homing switch	-	0-3	0	P
P5.72	Super multi-turn mode	-	0-1	0	P
P5.73	Digital trigger mode for PTP control	-	0-1	0	P
P5.74	Digital output mode for PTP control	-	0-4	0	P

Function code	Name	Unit	Range	Default	Applicable mode
P5.75	PTP interruption pause enable	-	0-1	0	P
P5.76	Positioning compensation value 22	-	-2147483.646-2147483.647	0	PST
P5.77	Positioning compensation value 23	-	-2147483.646-2147483.647	0	PST
P5.78	Positioning compensation value 24	-	-2147483.646-2147483.647	0	PST
P5.79	Positioning compensation value 25	-	-2147483.646-2147483.647	0	PST
P5.80	Positioning compensation value 26	-	-2147483.646-2147483.647	0	PST
P5.81	Positioning compensation value 27	-	-2147483.646-2147483.647	0	PST
P5.82	Positioning compensation value 28	-	-2147483.646-2147483.647	0	PST
P5.83	Positioning compensation value 29	-	-2147483.646-2147483.647	0	PST
P5.84	Positioning compensation value 30	-	-2147483.646-2147483.647	0	PST
P5.85	Positioning compensation value 31	-	-2147483.646-2147483.647	0	PST
P5.86	Positioning compensation value 32	-	-2147483.646-2147483.647	0	PST
P5.87	Positioning compensation	-	-2147483.646-2147483.647	0	PST

Function code	Name	Unit	Range	Default	Applicable mode
	value 33				
P5.88	Positioning compensation value 34	-	-2147483.646~2147483.647	0	PST
P5.89	Positioning compensation value 35	-	-2147483.646~2147483.647	0	PST
P5.90	Positioning compensation value 36	-	-2147483.646~2147483.647	0	PST
P5.91	Positioning compensation value 37	-	-2147483.646~2147483.647	0	PST
P5.92	Positioning compensation value 38	-	-2147483.646~2147483.647	0	PST
P5.93	Positioning compensation value 39	-	-2147483.646~2147483.647	0	PST
P5.94	Positioning compensation value 40	-	-2147483.646~2147483.647	0	PST
P5.95	Positioning compensation value 41	-	-2147483.646~2147483.647	0	PST
P5.96	Positioning compensation value 42	-	-2147483.646~2147483.647	0	PST
P5.97	Positioning compensation value 43	-	-2147483.646~2147483.647	0	PST
P5.98	Positioning compensation value 44	-	-2147483.646~2147483.647	0	PST
P5.99	Positioning compensation value 45	-	-2147483.646~2147483.647	0	PST

Function code	Name	Unit	Range	Default	Applicable mode
P6 Application functions					
P6.00	Forward low jogging speed	r/min	0-6000	5	P
P6.01	Reverse low jogging speed	r/min	-6000-0	-5	P
P6.02	Data latching switch	-	0-1	0	P
P6.03	Position latching save mode	-	0-1	0	P
P6.04	Forward high jogging speed	r/min	0-6000	60	P
P6.05	Reverse high jogging speed	r/min	-6000-0	-60	P
P6.06	Enable terminal jogging	-	0-1	1	P
P6.20	Turret function switch	-	0-1	0	P
P6.21	Knives per turret	piece	1-128	16	P
P6.22	Pulses per turret rotation	reference unit	2-(231-1)	10000	P
P6.23	Turret starting point	reference unit	-(231-2)-(231-2)	0	P
P6.30	Gantry synchronization function switch	-	0-1	0	P
P6.31	Speed control gain for gantry synchronization	Hz	0.0-3276.7	0	P
P6.32	Speed control integral for gantry synchronization	ms	0.1-1000	1000	P
P6.33	Position control gain for gantry synchronization	1/s	0.0-3276.7	1000	P
P6.34	Torque filter for gantry synchronization	ms	0.00-64.00	0.00	P

Function code	Name	Unit	Range	Default	Applicable mode
	compensation				
P6.35	Speed filter for gantry synchronization compensation	ms	0.00–64.00	0.00	P
P6.36	Bandwidth ratio for gantry synchronization control	%	0–1000	0	P
P6.37	Master/slave selection for gantry synchronization	-	0–1	0	P
P6.38	Retreat distance for gantry synchronization alignment	reference unit	-(231-2)–(231-2)	10000	P
P6.39	Retreat speed for gantry synchronization alignment	r/min	1–200	60	P
P6.40	Approaching speed for gantry synchronization alignment	r/min	1–60	5	P
P6.41	Gantry alignment direction	-	0–1	0	P
P6.42	Function switch of the fixed block	-	0–1	0	P
P6.43	Clamping torque of fixed block	Nm	0–150	1.00	P
P6.44	Max. follow-up error of the fixed block	pulse	0–2147483647	1000	P
P6.45	Monitoring window of the fixed block	pulse	0–2147483647	100	P

Function code	Name	Unit	Range	Default	Applicable mode
P6.50*	Magnetic pole detection startup command	-	0-1	0	PST
P6.51	Magnetic pole detection speed gain	Hz	1-2000	40	PST
P6.52	Speed integral time constant of magnetic pole detection	ms	0.15-512	30	PST
P6.53	Magnetic pole detection inertia ratio	%	0-20000	100	PST
P6.54	Rotary speed command of magnetic pole detection	mm/s	0-1000	50	PST
P6.55	Linear speed command of magnetic pole detection	mm/s	0-100	20	PST
P6.56	ACC/DEC time of magnetic pole detection command	ms	0-100	25	PST
P6.57	Constant speed time of magnetic pole detection speed command	ms	0-300	0	PST
P6.58	Wait time of magnetic pole detection speed command	ms	50-500	100	PST
P6.59	Repeat times of magnetic pole detection	-	0-10	4	PST
P6.60	Rotary movable	rev	0.001-32.767	0.250	PST

Function code	Name	Unit	Range	Default	Applicable mode
	range of magnetic pole detection				
P6.61	Linear movable range of magnetic pole detection	mm	1-32767	10	PST
P6.62	Gain without integral for pole detection	%	0-100	0.30	PST
P6.63	Starting time without integral for pole detection	%	0-100	30	PST
P6.64	Torque in checking process for pole detection	%	0-200	100	PST
P6.65	ACC/DEC time of torque in checking process for pole detection	ms	0-1000	10	PST
P6.66	Constant time of torque in checking process for pole detection	ms	0-3000	1500	PST
P6.67	Allowable error range of magnetic pole detection	deg	0-30	10	PST
P6.68	Retrograde threshold in magnetic pole detection operation	%	0-100	15	PST
P6.69	Retrograde threshold in magnetic pole detection waiting	%	0-100	50	PST
P6.70	Magnetic pole detection overspeed	%	100-500	180	PST

Function code	Name	Unit	Range	Default	Applicable mode
	threshold				
P6.71	Positioning compensation enabling	-	0-1	0	PST
P6.72	Positioning compensation unit	-	0-6	0	PST
P6.73	Starting position of positioning compensation	-	2147483646-2147483647	0	PST
P6.74	Points of position compensation	-	0-1000	100	PST
P6.75	Starting index bias of positioning compensation	-	0-1000	0	PST
P6.76	Positioning compensation distance	-	0-100000	100	PST
P6.77	Gear ratio numerator of positioning compensation	-	-2147483646-2147483647	1	PST
P6.78	Gear ratio denominator of positioning compensation	-	1-2147483647	1	PST
P6.79	Positioning compensation value 1	-	-2147483.646-2147483.647	0	PST
P6.80	Positioning compensation value 2	-	-2147483.646-2147483.647	0	PST
P6.81	Positioning compensation value 3	-	-2147483.646-2147483.647	0	PST
P6.82	Positioning compensation value 4	-	-2147483.646-2147483.647	0	PST

Function code	Name	Unit	Range	Default	Applicable mode
P6.83	Positioning compensation value 5	-	-2147483.646~2147483.647	0	PST
P6.84	Positioning compensation value 6	-	-2147483.646~2147483.647	0	PST
P6.85	Positioning compensation value 7	-	-2147483.646~2147483.647	0	PST
P6.86	Positioning compensation value 8	-	-2147483.646~2147483.647	0	PST
P6.87	Positioning compensation value 9	-	-2147483.646~2147483.647	0	PST
P6.88	Positioning compensation value 10	-	-2147483.646~2147483.647	0	PST
P6.89	Positioning compensation value 11	-	-2147483.646~2147483.647	0	PST
P6.90	Positioning compensation value 12	-	-2147483.646~2147483.647	0	PST
P6.91	Positioning compensation value 13	-	-2147483.646~2147483.647	0	PST
P6.92	Positioning compensation value 14	-	-2147483.646~2147483.647	0	PST
P6.93	Positioning compensation value 15	-	-2147483.646~2147483.647	0	PST
P6.94	Positioning compensation value 16	-	-2147483.646~2147483.647	0	PST
P6.95	Positioning	-	-2147483.646~2147483.647	0	PST

Function code	Name	Unit	Range	Default	Applicable mode
	compensation value 17				
P6.96	Positioning compensation value 18	-	-2147483.646~2147483.647	0	PST
P6.97	Positioning compensation value 19	-	-2147483.646~2147483.647	0	PST
P6.98	Positioning compensation value 20	-	-2147483.646~2147483.647	0	PST
P6.99	Positioning compensation value 21	-	-2147483.646~2147483.647	0	PST
PtP0 PTP control					
PtP0.00	Control word of segment 00	-	0~0x7FFFFFFF	0x00000000	P
PtP0.01	Position of segment 00	reference unit	-(231-1)~(231-1)	0	P
PtP0.02	Control word of segment 01	-	0~0x7FFFFFFF	0x00000000	P
PtP0.03	Position of segment 01	reference unit	-(231-1)~(231-1)	0	P
PtP0.04	Control word of segment 02	-	0~0x7FFFFFFF	0x00000000	P
PtP0.05	Position of segment 02	reference unit	-(231-1)~(231-1)	0	P
PtP0.06	Control word of segment 03	-	0~0x7FFFFFFF	0x00000000	P
PtP0.07	Position of segment 03	reference unit	-(231-1)~(231-1)	0	P
PtP0.08	Control word of segment 04	-	0~0x7FFFFFFF	0x00000000	P
PtP0.09	Position of segment 04	reference unit	-(231-1)~(231-1)	0	P
PtP0.10	Control word of segment 05	-	0~0x7FFFFFFF	0x00000000	P

Function code	Name	Unit	Range	Default	Applicable mode
PtP0.11	Position of segment 05	reference unit	-(231-1)-(231-1)	0	P
PtP0.12	Control word of segment 06	-	0-0x7FFFFFFF	0x00000000	P
PtP0.13	Position of segment 06	reference unit	-(231-1)-(231-1)	0	P
PtP0.14	Control word of segment 07	-	0-0x7FFFFFFF	0x00000000	P
PtP0.15	Position of segment 07	reference unit	-(231-1)-(231-1)	0	P
PtP0.16	Control word of segment 08	-	0-0x7FFFFFFF	0x00000000	P
PtP0.17	Position of segment 08	reference unit	-(231-1)-(231-1)	0	P
PtP0.18	Control word of segment 09	-	0-0x7FFFFFFF	0x00000000	P
PtP0.19	Position of segment 09	reference unit	-(231-1)-(231-1)	0	P
PtP0.20	Control word of segment 10	-	0-0x7FFFFFFF	0x00000000	P
PtP0.21	Position of segment 10	reference unit	-(231-1)-(231-1)	0	P
PtP0.22	Control word of segment 11	-	0-0x7FFFFFFF	0x00000000	P
PtP0.23	Position of segment 11	reference unit	-(231-1)-(231-1)	0	P
PtP0.24	Control word of segment 12	-	0-0x7FFFFFFF	0x00000000	P
PtP0.25	Position of segment 12	reference unit	-(231-1)-(231-1)	0	P
PtP0.26	Control word of segment 13	-	0-0x7FFFFFFF	0x00000000	P
PtP0.27	Position of segment 13	reference unit	-(231-1)-(231-1)	0	P
PtP0.28	Control word of segment 14	-	0-0x7FFFFFFF	0x00000000	P
PtP0.29	Position of	reference	-(231-1)-(231-1)	0	P

Function code	Name	Unit	Range	Default	Applicable mode
	segment 14	unit			
PtP0.30	Control word of segment 15	-	0-0x7FFFFFFF	0x00000000	P
PtP0.31	Position of segment 15	reference unit	-(231-1)-(231-1)	0	P
PtP0.32	Control word of segment 16	-	0-0x7FFFFFFF	0x00000000	P
PtP0.33	Position of segment 16	reference unit	-(231-1)-(231-1)	0	P
PtP0.34	Control word of segment 17	-	0-0x7FFFFFFF	0x00000000	P
PtP0.35	Position of segment 17	reference unit	-(231-1)-(231-1)	0	P
PtP0.36	Control word of segment 18	-	0-0x7FFFFFFF	0x00000000	P
PtP0.37	Position of segment 18	reference unit	-(231-1)-(231-1)	0	P
PtP0.38	Control word of segment 19	-	0-0x7FFFFFFF	0x00000000	P
PtP0.39	Position of segment 19	reference unit	-(231-1)-(231-1)	0	P
PtP0.40	Control word of segment 20	-	0-0x7FFFFFFF	0x00000000	P
PtP0.41	Position of segment 20	reference unit	-(231-1)-(231-1)	0	P
PtP0.42	Control word of segment 21	-	0-0x7FFFFFFF	0x00000000	P
PtP0.43	Position of segment 21	reference unit	-(231-1)-(231-1)	0	P
PtP0.44	Control word of segment 22	-	0-0x7FFFFFFF	0x00000000	P
PtP0.45	Position of segment 22	reference unit	-(231-1)-(231-1)	0	P
PtP0.46	Control word of segment 23	-	0-0x7FFFFFFF	0x00000000	P
PtP0.47	Position of segment 23	reference unit	-(231-1)-(231-1)	0	P

Function code	Name	Unit	Range	Default	Applicable mode
PtP0.48	Control word of segment 24	-	0-0x7FFFFFFF	0x00000000	P
PtP0.49	Position of segment 24	reference unit	-(231-1)-(231-1)	0	P
PtP0.50	Control word of segment 25	-	0-0x7FFFFFFF	0x00000000	P
PtP0.51	Position of segment 25	reference unit	-(231-1)-(231-1)	0	P
PtP0.52	Control word of segment 26	-	0-0x7FFFFFFF	0x00000000	P
PtP0.53	Position of segment 26	reference unit	-(231-1)-(231-1)	0	P
PtP0.54	Control word of segment 27	-	0-0x7FFFFFFF	0x00000000	P
PtP0.55	Position of segment 27	reference unit	-(231-1)-(231-1)	0	P
PtP0.56	Control word of segment 28	-	0-0x7FFFFFFF	0x00000000	P
PtP0.57	Position of segment 28	reference unit	-(231-1)-(231-1)	0	P
PtP0.58	Control word of segment 29	-	0-0x7FFFFFFF	0x00000000	P
PtP0.59	Position of segment 29	reference unit	-(231-1)-(231-1)	0	P
PtP0.60	Control word of segment 30	-	0-0x7FFFFFFF	0x00000000	P
PtP0.61	Position of segment 30	reference unit	-(231-1)-(231-1)	0	P
PtP0.62	Control word of segment 31	-	0-0x7FFFFFFF	0x00000000	P
PtP0.63	Position of segment 31	reference unit	-(231-1)-(231-1)	0	P
PtP0.64	Control word of segment 32	-	0-0x7FFFFFFF	0x00000000	P
PtP0.65	Position of segment 32	reference unit	-(231-1)-(231-1)	0	P
PtP0.66	Control word of	-	0-0x7FFFFFFF	0x00000000	P

Function code	Name	Unit	Range	Default	Applicable mode
	segment 33			00	
PtP0.67	Position of segment 33	reference unit	-(231-1)-(231-1)	0	P
PtP0.68	Control word of segment 34	-	0-0x7FFFFFFF	0x00000000	P
PtP0.69	Position of segment 34	reference unit	-(231-1)-(231-1)	0	P
PtP0.70	Control word of segment 35	-	0-0x7FFFFFFF	0x00000000	P
PtP0.71	Position of segment 35	reference unit	-(231-1)-(231-1)	0	P
PtP0.72	Control word of segment 36	-	0-0x7FFFFFFF	0x00000000	P
PtP0.73	Position of segment 36	reference unit	-(231-1)-(231-1)	0	P
PtP0.74	Control word of segment 37	-	0-0x7FFFFFFF	0x00000000	P
PtP0.75	Position of segment 37	reference unit	-(231-1)-(231-1)	0	P
PtP0.76	Control word of segment 38	-	0-0x7FFFFFFF	0x00000000	P
PtP0.77	Position of segment 38	reference unit	-(231-1)-(231-1)	0	P
PtP0.78	Control word of segment 39	-	0-0x7FFFFFFF	0x00000000	P
PtP0.79	Position of segment 39	reference unit	-(231-1)-(231-1)	0	P
PtP0.80	Control word of segment 40	-	0-0x7FFFFFFF	0x00000000	P
PtP0.81	Position of segment 40	reference unit	-(231-1)-(231-1)	0	P
PtP0.82	Control word of segment 41	-	0-0x7FFFFFFF	0x00000000	P
PtP0.83	Position of segment 41	reference unit	-(231-1)-(231-1)	0	P
PtP0.84	Control word of segment 42	-	0-0x7FFFFFFF	0x00000000	P

Function code	Name	Unit	Range	Default	Applicable mode
PtP0.85	Position of segment 42	reference unit	-(231-1)-(231-1)	0	P
PtP0.86	Control word of segment 43	-	0-0x7FFFFFFF	0x00000000	P
PtP0.87	Position of segment 43	reference unit	-(231-1)-(231-1)	0	P
PtP0.88	Control word of segment 44	-	0-0x7FFFFFFF	0x00000000	P
PtP0.89	Position of segment 44	reference unit	-(231-1)-(231-1)	0	P
PtP0.90	Control word of segment 45	-	0-0x7FFFFFFF	0x00000000	P
PtP0.91	Position of segment 45	reference unit	-(231-1)-(231-1)	0	P
PtP0.92	Control word of segment 46	-	0-0x7FFFFFFF	0x00000000	P
PtP0.93	Position of segment 46	reference unit	-(231-1)-(231-1)	0	P
PtP0.94	Control word of segment 47	-	0-0x7FFFFFFF	0x00000000	P
PtP0.95	Position of segment 47	reference unit	-(231-1)-(231-1)	0	P
PtP0.96	Control word of segment 48	-	0-0x7FFFFFFF	0x00000000	P
PtP0.97	Position of segment 48	reference unit	-(231-1)-(231-1)	0	P
PtP0.98	Control word of segment 49	-	0-0x7FFFFFFF	0x00000000	P
PtP0.99	Position of segment 49	reference unit	-(231-1)-(231-1)	0	P
PtP1 PTP control					
PtP1.00	Control word of segment 50	-	0-0x7FFFFFFF	0x00000000	P
PtP1.01	Position of segment 50	reference unit	-(231-1)-(231-1)	0	P
PtP1.02	Control word of segment 51	-	0-0x7FFFFFFF	0x00000000	P

Function code	Name	Unit	Range	Default	Applicable mode
PtP1.03	Position of segment 51	reference unit	-(231-1)-(231-1)	0	P
PtP1.04	Control word of segment 52	-	0-0x7FFFFFFF	0x00000000	P
PtP1.05	Position of segment 52	reference unit	-(231-1)-(231-1)	0	P
PtP1.06	Control word of segment 53	-	0-0x7FFFFFFF	0x00000000	P
PtP1.07	Position of segment 53	reference unit	-(231-1)-(231-1)	0	P
PtP1.08	Control word of segment 54	-	0-0x7FFFFFFF	0x00000000	P
PtP1.09	Position of segment 54	reference unit	-(231-1)-(231-1)	0	P
PtP1.10	Control word of segment 55	-	0-0x7FFFFFFF	0x00000000	P
PtP1.11	Position of segment 55	reference unit	-(231-1)-(231-1)	0	P
PtP1.12	Control word of segment 56	-	0-0x7FFFFFFF	0x00000000	P
PtP1.13	Position of segment 56	reference unit	-(231-1)-(231-1)	0	P
PtP1.14	Control word of segment 57	-	0-0x7FFFFFFF	0x00000000	P
PtP1.15	Position of segment 57	reference unit	-(231-1)-(231-1)	0	P
PtP1.16	Control word of segment 58	-	0-0x7FFFFFFF	0x00000000	P
PtP1.17	Position of segment 58	reference unit	-(231-1)-(231-1)	0	P
PtP1.18	Control word of segment 59	-	0-0x7FFFFFFF	0x00000000	P
PtP1.19	Position of segment 59	reference unit	-(231-1)-(231-1)	0	P
PtP1.20	Control word of segment 60	-	0-0x7FFFFFFF	0x00000000	P
PtP1.21	Position of	reference	-(231-1)-(231-1)	0	P

Function code	Name	Unit	Range	Default	Applicable mode
	segment 60	unit			
PtP1.22	Control word of segment 61	-	0-0x7FFFFFFF	0x00000000	P
PtP1.23	Position of segment 61	reference unit	-(231-1)-(231-1)	0	P
PtP1.24	Control word of segment 62	-	0-0x7FFFFFFF	0x00000000	P
PtP1.25	Position of segment 62	reference unit	-(231-1)-(231-1)	0	P
PtP1.26	Control word of segment 63	-	0-0x7FFFFFFF	0x00000000	P
PtP1.27	Position of segment 63	reference unit	-(231-1)-(231-1)	0	P
PtP1.28	Control word of segment 64	-	0-0x7FFFFFFF	0x00000000	P
PtP1.29	Position of segment 64	reference unit	-(231-1)-(231-1)	0	P
PtP1.30	Control word of segment 65	-	0-0x7FFFFFFF	0x00000000	P
PtP1.31	Position of segment 65	reference unit	-(231-1)-(231-1)	0	P
PtP1.32	Control word of segment 66	-	0-0x7FFFFFFF	0x00000000	P
PtP1.33	Position of segment 66	reference unit	-(231-1)-(231-1)	0	P
PtP1.34	Control word of segment 67	-	0-0x7FFFFFFF	0x00000000	P
PtP1.35	Position of segment 67	reference unit	-(231-1)-(231-1)	0	P
PtP1.36	Control word of segment 68	-	0-0x7FFFFFFF	0x00000000	P
PtP1.37	Position of segment 68	reference unit	-(231-1)-(231-1)	0	P
PtP1.38	Control word of segment 69	-	0-0x7FFFFFFF	0x00000000	P
PtP1.39	Position of segment 69	reference unit	-(231-1)-(231-1)	0	P

Function code	Name	Unit	Range	Default	Applicable mode
PtP1.40	Control word of segment 70	-	0-0x7FFFFFFF	0x00000000	P
PtP1.41	Position of segment 70	reference unit	-(231-1)-(231-1)	0	P
PtP1.42	Control word of segment 71	-	0-0x7FFFFFFF	0x00000000	P
PtP1.43	Position of segment 71	reference unit	-(231-1)-(231-1)	0	P
PtP1.44	Control word of segment 72	-	0-0x7FFFFFFF	0x00000000	P
PtP1.45	Position of segment 72	reference unit	-(231-1)-(231-1)	0	P
PtP1.46	Control word of segment 73	-	0-0x7FFFFFFF	0x00000000	P
PtP1.47	Position of segment 73	reference unit	-(231-1)-(231-1)	0	P
PtP1.48	Control word of segment 74	-	0-0x7FFFFFFF	0x00000000	P
PtP1.49	Position of segment 74	reference unit	-(231-1)-(231-1)	0	P
PtP1.50	Control word of segment 75	-	0-0x7FFFFFFF	0x00000000	P
PtP1.51	Position of segment 75	reference unit	-(231-1)-(231-1)	0	P
PtP1.52	Control word of segment 76	-	0-0x7FFFFFFF	0x00000000	P
PtP1.53	Position of segment 76	reference unit	-(231-1)-(231-1)	0	P
PtP1.54	Control word of segment 77	-	0-0x7FFFFFFF	0x00000000	P
PtP1.55	Position of segment 77	reference unit	-(231-1)-(231-1)	0	P
PtP1.56	Control word of segment 78	-	0-0x7FFFFFFF	0x00000000	P
PtP1.57	Position of segment 78	reference unit	-(231-1)-(231-1)	0	P
PtP1.58	Control word of	-	0-0x7FFFFFFF	0x00000000	P

Function code	Name	Unit	Range	Default	Applicable mode
	segment 79			00	
PtP1.59	Position of segment 79	reference unit	-(231-1)-(231-1)	0	P
PtP1.60	Control word of segment 80	-	0-0x7FFFFFFF	0x00000000	P
PtP1.61	Position of segment 80	reference unit	-(231-1)-(231-1)	0	P
PtP1.62	Control word of segment 81	-	0-0x7FFFFFFF	0x00000000	P
PtP1.63	Position of segment 81	reference unit	-(231-1)-(231-1)	0	P
PtP1.64	Control word of segment 82	-	0-0x7FFFFFFF	0x00000000	P
PtP1.65	Position of segment 82	reference unit	-(231-1)-(231-1)	0	P
PtP1.66	Control word of segment 83	-	0-0x7FFFFFFF	0x00000000	P
PtP1.67	Position of segment 83	reference unit	-(231-1)-(231-1)	0	P
PtP1.68	Control word of segment 84	-	0-0x7FFFFFFF	0x00000000	P
PtP1.69	Position of segment 84	reference unit	-(231-1)-(231-1)	0	P
PtP1.70	Control word of segment 85	-	0-0x7FFFFFFF	0x00000000	P
PtP1.71	Position of segment 85	reference unit	-(231-1)-(231-1)	0	P
PtP1.72	Control word of segment 86	-	0-0x7FFFFFFF	0x00000000	P
PtP1.73	Position of segment 86	reference unit	-(231-1)-(231-1)	0	P
PtP1.74	Control word of segment 87	-	0-0x7FFFFFFF	0x00000000	P
PtP1.75	Position of segment 87	reference unit	-(231-1)-(231-1)	0	P
PtP1.76	Control word of segment 88	-	0-0x7FFFFFFF	0x00000000	P

Function code	Name	Unit	Range	Default	Applicable mode
PtP1.77	Position of segment 88	reference unit	-(231-1)-(231-1)	0	P
PtP1.78	Control word of segment 89	-	0-0x7FFFFFFF	0x00000000	P
PtP1.79	Position of segment 89	reference unit	-(231-1)-(231-1)	0	P
PtP1.80	Control word of segment 90	-	0-0x7FFFFFFF	0x00000000	P
PtP1.81	Position of segment 90	reference unit	-(231-1)-(231-1)	0	P
PtP1.82	Control word of segment 91	-	0-0x7FFFFFFF	0x00000000	P
PtP1.83	Position of segment 91	reference unit	-(231-1)-(231-1)	0	P
PtP1.84	Control word of segment 92	-	0-0x7FFFFFFF	0x00000000	P
PtP1.85	Position of segment 92	reference unit	-(231-1)-(231-1)	0	P
PtP1.86	Control word of segment 93	-	0-0x7FFFFFFF	0x00000000	P
PtP1.87	Position of segment 93	reference unit	-(231-1)-(231-1)	0	P
PtP1.88	Control word of segment 94	-	0-0x7FFFFFFF	0x00000000	P
PtP1.89	Position of segment 94	reference unit	-(231-1)-(231-1)	0	P
PtP1.90	Control word of segment 95	-	0-0x7FFFFFFF	0x00000000	P
PtP1.91	Position of segment 95	reference unit	-(231-1)-(231-1)	0	P
PtP1.92	Control word of segment 96	-	0-0x7FFFFFFF	0x00000000	P
PtP1.93	Position of segment 96	reference unit	-(231-1)-(231-1)	0	P
PtP1.94	Control word of segment 97	-	0-0x7FFFFFFF	0x00000000	P
PtP1.95	Position of	reference	-(231-1)-(231-1)	0	P

Function code	Name	Unit	Range	Default	Applicable mode
	segment 97	unit			
PtP1.96	Control word of segment 98	-	0-0x7FFFFFFF	0x00000000	P
PtP1.97	Position of segment 98	reference unit	-(231-1)-(231-1)	0	P
PtP1.98	Control word of segment 99	-	0-0x7FFFFFFF	0x00000000	P
PtP1.99	Position of segment 99	reference unit	-(231-1)-(231-1)	0	P
PtP2 PTP control					
PtP2.00	Control word of segment 100	-	0-0x7FFFFFFF	0x00000000	P
PtP2.01	Position of segment 100	reference unit	-(231-1)-(231-1)	0	P
PtP2.02	Control word of segment 101	-	0-0x7FFFFFFF	0x00000000	P
PtP2.03	Position of segment 101	reference unit	-(231-1)-(231-1)	0	P
PtP2.04	Control word of segment 102	-	0-0x7FFFFFFF	0x00000000	P
PtP2.05	Position of segment 102	reference unit	-(231-1)-(231-1)	0	P
PtP2.06	Control word of segment 103	-	0-0x7FFFFFFF	0x00000000	P
PtP2.07	Position of segment 103	reference unit	-(231-1)-(231-1)	0	P
PtP2.08	Control word of segment 104	-	0-0x7FFFFFFF	0x00000000	P
PtP2.09	Position of segment 104	reference unit	-(231-1)-(231-1)	0	P
PtP2.10	Control word of segment 105	-	0-0x7FFFFFFF	0x00000000	P
PtP2.11	Position of segment 105	reference unit	-(231-1)-(231-1)	0	P
PtP2.12	Control word of segment 106	-	0-0x7FFFFFFF	0x00000000	P
PtP2.13	Position of	reference	-(231-1)-(231-1)	0	P

Function code	Name	Unit	Range	Default	Applicable mode
	segment 106	unit			
PtP2.14	Control word of segment 107	-	0-0x7FFFFFFF	0x00000000	P
PtP2.15	Position of segment 107	reference unit	-(231-1)-(231-1)	0	P
PtP2.16	Control word of segment 108	-	0-0x7FFFFFFF	0x00000000	P
PtP2.17	Position of segment 108	reference unit	-(231-1)-(231-1)	0	P
PtP2.18	Control word of segment 109	-	0-0x7FFFFFFF	0x00000000	P
PtP2.19	Position of segment 109	reference unit	-(231-1)-(231-1)	0	P
PtP2.20	Control word of segment 110	-	0-0x7FFFFFFF	0x00000000	P
PtP2.21	Position of segment 110	reference unit	-(231-1)-(231-1)	0	P
PtP2.22	Control word of segment 111	-	0-0x7FFFFFFF	0x00000000	P
PtP2.23	Position of segment 111	reference unit	-(231-1)-(231-1)	0	P
PtP2.24	Control word of segment 112	-	0-0x7FFFFFFF	0x00000000	P
PtP2.25	Position of segment 112	reference unit	-(231-1)-(231-1)	0	P
PtP2.26	Control word of segment 113	-	0-0x7FFFFFFF	0x00000000	P
PtP2.27	Position of segment 113	reference unit	-(231-1)-(231-1)	0	P
PtP2.28	Control word of segment 114	-	0-0x7FFFFFFF	0x00000000	P
PtP2.29	Position of segment 114	reference unit	-(231-1)-(231-1)	0	P
PtP2.30	Control word of segment 115	-	0-0x7FFFFFFF	0x00000000	P
PtP2.31	Position of segment 115	reference unit	-(231-1)-(231-1)	0	P

Function code	Name	Unit	Range	Default	Applicable mode
PtP2.32	Control word of segment 116	-	0-0x7FFFFFFF	0x00000000	P
PtP2.33	Position of segment 116	reference unit	-(231-1)-(231-1)	0	P
PtP2.34	Control word of segment 117	-	0-0x7FFFFFFF	0x00000000	P
PtP2.35	Position of segment 117	reference unit	-(231-1)-(231-1)	0	P
PtP2.36	Control word of segment 118	-	0-0x7FFFFFFF	0x00000000	P
PtP2.37	Position of segment 118	reference unit	-(231-1)-(231-1)	0	P
PtP2.38	Control word of segment 119	-	0-0x7FFFFFFF	0x00000000	P
PtP2.39	Position of segment 119	reference unit	-(231-1)-(231-1)	0	P
PtP2.40	Control word of segment 120	-	0-0x7FFFFFFF	0x00000000	P
PtP2.41	Position of segment 120	reference unit	-(231-1)-(231-1)	0	P
PtP2.42	Control word of segment 121	-	0-0x7FFFFFFF	0x00000000	P
PtP2.43	Position of segment 121	reference unit	-(231-1)-(231-1)	0	P
PtP2.44	Control word of segment 122	-	0-0x7FFFFFFF	0x00000000	P
PtP2.45	Position of segment 122	reference unit	-(231-1)-(231-1)	0	P
PtP2.46	Control word of segment 123	-	0-0x7FFFFFFF	0x00000000	P
PtP2.47	Position of segment 123	reference unit	-(231-1)-(231-1)	0	P
PtP2.48	Control word of segment 124	-	0-0x7FFFFFFF	0x00000000	P
PtP2.49	Position of segment 124	reference unit	-(231-1)-(231-1)	0	P
PtP2.50	Control word of	-	-(231-1)-(231-1)	0x00000000	P

Function code	Name	Unit	Range	Default	Applicable mode
	segment 125			00	
PtP2.51	Position of segment 125	reference unit	-(231-1)–(231-1)	0	P
PtP2.52	Control word of segment 126	-	0–0x7FFFFFFF	0x00000000	P
PtP2.53	Position of segment 126	reference unit	-(231-1)–(231-1)	0	P
PtP2.54	Control word of segment 127	-	0–0x7FFFFFFF	0x00000000	P
PtP2.55	Position of segment 127	reference unit	-(231-1)–(231-1)	0	P

A.1.2 State monitoring parameter list

Function code	Name	Unit	Range	Applicable mode
R0 System monitoring				
R0.00	Motor rotation speed	r/min	-9999.9–9999.9	PST
R0.01	Speed command	r/min	-9999.9–9999.9	PST
R0.02	Accumulated feedback pulses	pulse	-(263-1)–(263-1)	P
R0.03	Accumulated command pulses	pulse	-(263-1)–(263-1)	P
R0.04	Residual pulses	pulse	-(231-1)–(231-1)	P
R0.05	Hybrid control deviation	pulse	-(23-1)–(231-1)	P
R0.06	Current torque	%	-500.0–500.0	PST
R0.07	Main circuit DC voltage	V	0.0–1000.0	PST
R0.08	Control power voltage	V	0.0–1000.0	PST
R0.09	Output voltage	V _{rms}	0.0–1000.0	PST
R0.10	Output current	A _{rms}	0.00–1000.00	PST
R0.11	Drive temperature	°C	-55.0–180.0	PST
R0.12	Torque limit	%	-500.0–500.0	PST
R0.13	Encoder feedback value	pulse	0–(232-1)	PST
R0.14	Rotor position relative to Z pulse	pulse	0–(231-1)	PST
R0.15	Load inertia ratio	%	0–10000	PST
R0.16	Output power	%	-500.0–500.0	PST
R0.17	Motor load ratio	%	0–500	PST
R0.18	Numerator of actual electronic gear ratio	-	0–(231-1)	P

Function code	Name	Unit	Range	Applicable mode
R0.19	Denominator of actual electronic gear ratio	-	1-(231-1)	P
R0.20	Position command speed	r/min	-9999.9-9999.9	P
R0.21	Motor speed (filtering)	r/min	-9999.9-9999.9	PST
R0.22	PTP state	-	-1-4223	P
R0.23	Encoder absolute position feedback	pulse	-(231-1)-(231-1)	PST
R0.24	Encoder EEPROM data state	-	0-3	PST
R0.25	Turns of multi-turn encoder	-	-32768-32767	PST
R0.26	Available encoder type	-	0-6	PST
R0.27	EtherCAT clock synchronous correction state	-	0-1	PST
R0.28	State of CANopen state machine	-	0-18	PST
R0.29	PROFIBUS-DP slave node number	-	0-99	PST
R0.30	System state	-	0-8	PST
R0.31	IGBT state	-	0-1	PST
R0.32	Current mode	-	0-2	PST
R0.33	Power-on time	s	0-(231-1)	PST
R0.34	Running time	s	0-(231-1)	PST
R0.35	DSP software version	-	0.00-10.00	PST
R0.36	FPGA software version	-	0.00-10.00	PST
R0.37	Communication card software version	-	0.00-10.00	PST
R0.38	Drive SN 1	-	0-65535	PST
R0.39	Drive SN 2	-	0-65535	PST
R0.40	Drive SN 3	-	0-65535	PST
R0.41	Drive SN 4	-	0-65535	PST
R0.42	Drive SN 5	-	0-65535	PST
R0.43	Drive SN 6	-	0-65535	PST
R0.44	Absolute position of linear encoder (second encoder) in single circle	pulse	0-(231-1)	PST
R0.45	Speed feedback of the second encoder	r/min	-9999.9-9999.9	PST
R0.46	Detected speed of speed observer	r/min	-9999.9-9999.9	PST
R0.47	Feedback speed of speed observer	r/min	-9999.9-9999.9	PST
R0.48	Observing disturbance torque of	%	-1000.0-1000.0	PST

Function code	Name	Unit	Range	Applicable mode
	disturbance observer			
R0.49	Compensation value of fully-closed-loop vibration suppressor	r/min	-9999.9~9999.9	PST
R0.51	Observe load inertia ratio in real time	%	0~10000	PST
R0.52	Accumulated linear encoder (second encoder) position feedback (32-bit)	pulse	-(231-1)~(231-1)	PST
R0.53	Gantry synchronization position deviation	reference unit	-(231-1)~(231-1)	PST
R0.54	Linear encoder (second encoder) position feedback value	pulse	0~(231-1)	PST
R0.55	Encoder turn deviation after multi-turn position cleared	-	-(231-1)~(231-1)	PST
R0.56	Encoder feedback deviation after multi-turn position cleared	pulse	-(231-1)~(231-1)	PST
R0.57	Accumulated linear encoder (second encoder) position feedback (64-bit)	pulse	-(263-1)~(263-1)	PST
R0.58	Position inside the single-turn of the disk	pulse	-(231-1)~(231-1)	PST
R0.60	Motor temperature	°C	-55~200	PST
R0.61	Load ratio of main interrupt task	%	0.00~100.00	PST
R0.62	Load ratio of 1ms task	%	0.00~100.00	PST
R0.64	CIA402 control word	-	0~FFFF	PST
R0.65	CIA402 state word	-	0~FFFF	PST
R0.66	CIA402 control mode	-	0~65535	PST
R0.67	Network fault counting 0	-	0~65535	PST
R0.68	Network fault counting 1	-	0~65535	PST
R0.69	Rotary load single-turn position (Encoder unit)	Encoder unit	-2147483647~2147483647	PST
R0.70	Rotary load single-turn position (User unit)	User unit	-2147483647~2147483647	PST
R0.71	Angle value of rotary load side	-	0~360.00	PST
R0.72	EtherCAT synchronization offset time	us	0~30000	PST

Function code	Name	Unit	Range	Applicable mode
R0.73	Positioning compensation state	-	0-3	PST
R0.99	Fault code	-	-32768-32767	PST
R1 I/O monitoring				
R1.00	Digital input state	-	0x000-0x3FF	PST
R1.01	Digital output state	-	0x00-0x3F	PST
R1.02	Original voltage of analog input 1	V	-10.000-10.000	PST
R1.03	Original voltage of analog input 2	V	-10.000-10.000	PST
R1.04	Original voltage of analog input 3	V	-10.000-10.000	PST
R1.05	Voltage of analog input 1	V	-10.000-10.000	PST
R1.06	Voltage of analog input 2	V	-10.000-10.000	PST
R1.07	Voltage of analog input 3	V	-10.000-10.000	PST
R1.08	Voltage of analog output 1	V	-10.000-10.000	PST
R1.09	Voltage of analog output 2	V	-10.000-10.000	PST
R1.11	Accumulated input pulses	reference unit	-(231-1)-(231-1)	PST
R1.12	Pulse position command	reference unit	-(231-1)-(231-1)	PST
R1.13	Pulse speed command	r/min	-10000.0-10000.0	PST
R1.14	Analog compensation speed	r/min	-10000.0-10000.0	PST
R1.15	Analog compensation torque	%	-1000.0-1000.0	PST
R1.16	Captured value of the first encoder in single circle	pulse	-214748364-214748364	PST
R1.17	Position feedback captured value of the first encoder	pulse	-214748364-214748364	P
R1.18	Captured value of the second encoder in single circle	pulse	-214748364-214748364	PST
R1.19	Position feedback captured value of the second encoder	pulse	-214748364-214748364	P
R1.20	Digital output function state	-	0-8000000	PST
R3 Fault recording				
R3.00	Fault code record	-	-	PST
R3.01	Power-on time when fault occurs	h	0-(231-1)	PST
R3.02	Running time when fault occurs	h	0-(231-1)	PST
R3.03	Motor speed when fault occurs	r/min	-20000-20000	PST
R3.04	Speed command when fault occurs	r/min	-20000-20000	PST
R3.05	Feedback pulse accumulation when fault occurs	reference unit	-(231-1)-(231-1)	P
R3.06	Command pulse accumulation	reference unit	-(231-1)-(231-1)	P

Function code	Name	Unit	Range	Applicable mode
	when fault occurs			
R3.07	Residual pulses when fault occurs	reference unit	-(231-1)~(231-1)	P
R3.08	Current torque when fault occurs	%	-500.0~500.0	PST
R3.09	Main circuit DC voltage when fault occurs	V	0.0~1000.0	PST
R3.10	Output voltage when fault occurs	Vrms	0.0~1000.0	PST
R3.11	Output current when fault occurs	Arms	0.00~1000.00	PST
R3.20	Last fault code	-	-	PST
R3.21	2nd-last fault code	-	-	PST
R3.22	3rd-last fault code	-	-	PST
R3.23	4th-last fault code	-	-	PST
R3.24	5th-last fault code	-	-	PST
R3.25	6th-last fault code	-	-	PST
R3.26	7th-last fault code	-	-	PST
R3.27	8th-last fault code	-	-	PST
R3.28	9th-last fault code	-	-	PST
R3.29	10th-last fault code	-	-	PST

A.2 Common monitoring parameters

Set value of P0.15	Meaning	Display	Unit	Corresponding parameter
[0]	Motor rotation speed	SPdFb	r/min	R0.00
1	Speed command	SPdcNd	r/min	R0.01
2	Accumulated feedback pulses	PLSFB	pulse	R0.02
3	Accumulated command pulses	PLScNd	pulse	R0.03
4	Residual pulses	PLSEr1	pulse	R0.04
5	Hybrid control deviation	PLSEr2	pulse	R0.05
6	Current torque	trqFb	%	R0.06
7	Main circuit DC voltage	Ubus1	V	R0.07
8	Control power voltage	Ubus2	V	R0.08
9	Output voltage	UoUt	Vrms	R0.09

Set value of P0.15	Meaning	Display	Unit	Corresponding parameter
10	Output current	OUT	Arms	R0.10
11	Drive temperature	TEMP	°C	R0.11
12	Torque limit	TORLMT	%	R0.12
13	Encoder feedback value	Enc.Fb	pulse	R0.13
14	Rotor position relative to Z pulse	Enc.ABS	pulse	R0.14
15	Load inertia ratio	J-r	%	R0.15
16	Output power	POWER	%	R0.16
17	Motor load ratio	LoAd-r	%	R0.17
18	Numerator of actual electronic gear ratio	nUN	-	R0.18
19	Denominator of actual electronic gear ratio	dEN	-	R0.19
20	Speed of position command	PL5SPD	r/min	R0.20
21	Motor speed (filtering)	SPdFb1	r/min	R0.21
22	PTP state	PTP.StS	-	R0.22
23	Encoder absolute position feedback	Enc.AB	pulse	R0.23

Note: When the LED digital tube displays POW.OFF, it indicates that the current main circuit is disconnected, and the display symbol is POW.OFF. When the LED digital tube displays VOL.LOW, it indicates that when it is in standby mode and the main circuit bus voltage is less than the undervoltage protection value of the main circuit, or the main circuit bus voltage is less than the main relay switching-on voltage after first power-on, and the display symbol is VOL.LOW.

Your Trusted Industry Automation Solution Provider



Shenzhen INVT Electric Co., Ltd.

Address: INVT Guangming Technology Building, Songbai Road, Matian,
Guangming District, Shenzhen, China

INVT Power Electronics (Suzhou) Co., Ltd.

Address: No. 1 Kuntun Mountain Road, Science & Technology Town,
Gaixin District, Suzhou, Jiangsu, China

Website: www.invt.com



INVT mobile website



INVT e-manual



6 6 0 0 1 - 0 1 3 4 5

Manual information may be subject to change without prior notice.

202406 (V1.0)